

NATIONAL HIGH MAGNETIC FIELD LABORATORY ANNUAL REPORT



Supported by:



THE FLORIDA STATE UNIVERSITY

Los Alamos
NATIONAL LABORATORY
EST. 1943

UF UNIVERSITY of
FLORIDA

ANNUAL REPORT

Published by:
**NATIONAL HIGH MAGNETIC
FIELD LABORATORY**

1800 East Paul Dirac Drive
Tallahassee, FL
32310-3706

Tel: 850-644-0311

Fax: 850-644-8350

www.magnet.fsu.edu

MAG LAB DIRECTOR

Greg Boebinger

ASSOCIATE DIRECTOR FOR MANAGEMENT AND ADMINISTRATION

Brian Fairhurst

EDITOR

Kathy Hedick

ART DIRECTION AND PRODUCTION

Savoy Brown

This document is available in alternate formats upon request.

Contact Kathy Hedick for assistance. If you would like to be added to our mailing list, please e-mail hedick@magnet.fsu.edu.

Trying to reduce your carbon footprint?



Sign up for an online subscription at
[http://www.magnet.fsu.edu/mediacenter/
publications/subscribe.aspx](http://www.magnet.fsu.edu/mediacenter/publications/subscribe.aspx)

TABLE OF CONTENTS

Chapter 1	2009 YEAR IN REVIEW	3
Chapter 2	8
RESEARCH HIGHLIGHTS	Condensed Matter Physics	10
	<i>Graphene, Basic Superconductivity, Other Condensed Matter, Qubits & Quantum Entanglement, Quantum Fluids & Solids, Condensed Matter Technique Development, Magnetism & Magnetic Materials</i>	
	Magnet Science & Technology	34
	<i>Applied Superconductivity, Engineering Materials, Magnet Technology</i>	
Chemistry	43	
<i>Magnetic Resonance Technique Development, Geochemistry, Chemistry</i>		
Life Sciences	54	
<i>Biochemistry, Biology</i>		
Chapter 3	USER PROGRAMS	63
Chapter 4	MAGNETS & MAGNET MATERIALS	85
Chapter 5	USER COLLABORATION GRANTS PROGRAM	97
Chapter 6	EDUCATION	100
Chapter 7	INDUSTRIAL PARTNERS & COLLABORATIONS....	106
Chapter 8	CONFERENCES & WORKSHOPS	114
Chapter 9	MANAGEMENT & ADMINISTRATION	116
Chapter 10	SCIENCE & RESEARCH PRODUCTIVITY	124
Appendices		162
A - User Facility Statistics		162
B - Research Reports by Category		187
C - Publications & Activities Index		206

Chapter 1: 2009 – Year in Review

The National High Magnetic Field Laboratory is one lab, with three sites and seven user programs. *One* is the key word; yet in years past, the user programs had different ways of assigning magnet time and keeping statistics. In 2009, efforts to standardize statistics and operations across all facilities reached critical mass, and by the New Year 2010, the magnet-time-request system first developed in 2003 and used by the DC Field and NMR user programs was redesigned to support all seven programs.

The user portal (<https://users.magnet.fsu.edu/>) is accessible in one click from the Magnet Lab home page, and includes all of the Magnet Lab's user policies and procedures, as well as sections of the NSF Cooperative Agreement that govern user operations.

Research reports up nearly 10 percent

Graphene was the research tour-de-force of 2009. Graphene research blossomed from an exciting new development with just a few groups involved to a major effort with 17 different user groups in 2009. Among these 17, six of the user groups were new to the Magnet Lab.

"New Users" are principal investigators who may be completely new users of the Magnet Lab or ones who are serving for the first time on their own research projects. The new user generally leads a group of researchers, some of whom may also be new to the Magnet Lab but are not included in the count. In 2009, the Magnet Lab reported 118 new users: 23 in the DC Field Facility, 28 in Pulsed Field Facility, 11 in Nuclear Magnetic Resonance, 15 in the Advanced Magnetic Resonance Imaging and Spectroscopy program, 20 in Electron Magnetic Resonance, and 21 in Ion Cyclotron Resonance.

This past year produced breakthrough science, highlights of which are included in Chapter 2. We know this because each year, we ask our users and research faculty to submit one-page abstracts of research made possible through the Mag Lab's user programs. These research reports provide an indication of the scope of scientific activity during the year.

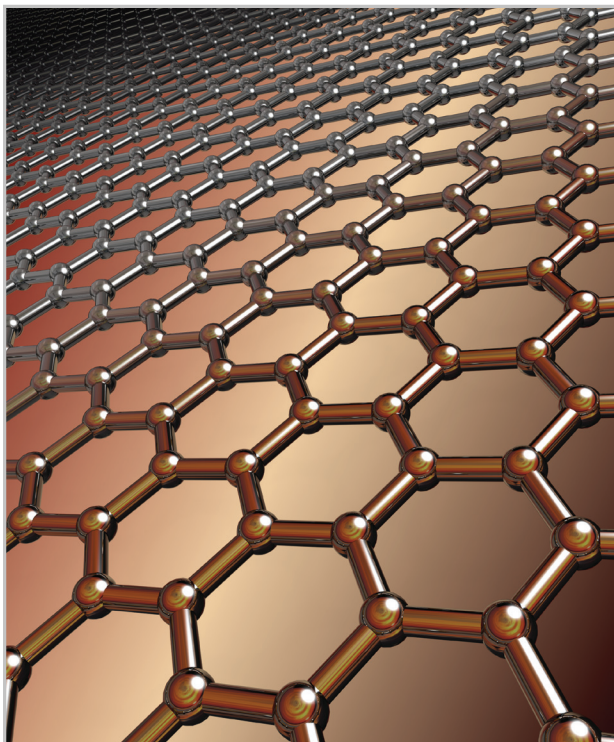

Artist illustration of graphene by Kevin John

After we receive the reports, the lab's Science Council, composed of scientists representing all three Magnet Lab sites, reviews each report and recommends which ones to forward to the director for inclusion in the Highlights Edition of *Mag Lab Reports*.

Research reports in 2009 were up nearly 10 percent: 416 research reports were received in 17 categories, representing the life sciences, chemistry, magnet science and technology, and condensed matter physics. (377 reports were submitted in 2008).

- 20% of the research activities (82 reports) were already published in 2009, many in prominent journals.
- An additional 6% of the reports were accepted for publication; 10% were submitted for publication; and 35% have manuscripts in preparation.
- The majority of research projects were funded by the U.S. National Science Foundation (just over 50 percent, including the User Collaboration Grants Program), the U.S. Department of Energy (approximately 13 percent), and the U.S. National Institutes of Health (10 percent). Other funding organizations included: American Heart Association; Burroughs Wellcome; Danish National Research Foundation; the Deutsche Forschungsgemeinschaft (Germany); Electric Power Research Institute; Agence Nationale de la Recherche (France); Iketani Science and Technology Foundation (Japan); Japan Society for the Promotion of Science; Keck Foundation; Korea National Research Foundation; NASA; National Sciences and Engineering Research Council (Canada); U.S. Air Force Office of Scientific Research; U.S. Army; U.S. Navy; U.S. Department of Agriculture; and numerous universities.

- ▶ The Magnet Lab User Collaboration Grants Program (UCGP) supported 41 of the 416 research activities and was the primary support for 24 projects. The UCGP encourages collaborations between internal and external investigators, promotes bold but risky efforts, and provides initial seed money for new faculty and research staff and facility enhancements. UCGP activities have produced wide-ranging enhancements to the user programs and are responsible for a high volume of publications in high-impact journals, including three articles in *Nature*, 16 in *Physical Review Letters*, and six in the *Journal of the American Chemical Society*. See Chapter 5 for detailed information about the UCGP.

Research by a Mag Lab collaboration including Steve Blackband made the cover of the July 2009 issue of *NeuroImage*.



Mag Lab research led by ASC researchers made the cover of the September 2009 issue of *Superconductor Science and Technology*

User program enhancements

In March of 2009, the Magnet Lab's largest user program, the DC Field Program, rolled out "flextime" for its users. Magnet shifts were extended by 2.5 hours each, providing users with up to 10 hours of magnet time each day or 41.5 hours per week. While at first blush flextime sounds as if it would stretch not just magnet hours but utility costs as well, that of course was not the case. Flextime introduced users to energy budgets. Each user is given an energy budget calculated on the prior 31½ hours of magnet time, and each group decides how to use its energy in a way that best meets its own scientific agenda.

DC Field Users also welcomed infrastructure enhancements in 2009, including updates to the cryogenics system and improvements in signal-to-noise ratio. A long planned update to a new top loading helium-3 and Variable Temperature Insert combination was completed, and the windows of the Millikelvin Facility were fitted with copper mesh screens to form a Faraday cage. This change reduced the noise level by about 20 db, improving NMR, tunnel diode oscillator and heat capacity measurements significantly.



One of the lab's many 2009 infrastructure improvement projects was the construction of a Faraday cage in the Millikelvin facility. Copper mesh covers even the windows to shield it from unwanted RF interference.

After an extensive review process, the Pulsed Field Facility initiated the first set of user experiments in the 85-tesla multi-shot magnet. Six proposals were selected for magnet time with 4 backup proposals also selected. The new 16 kV, 4 MJ user capacitor bank safety review at the Pulsed Field Facility was completed in 2009 and the equipment is expected to be commissioned in 2010. Magnet designs are being developed to take full advantage of this new capability.

The High B/T Facility at the University of Florida opened a fast-turnaround annex — conveniently located adjacent to the Microkelvin Laboratory in Williamson Hall — in 2009 to allow users to test samples and experimental cells before using the high-field demagnetization cryostats.

The EMR program was enhanced in the summer of 2009 with the addition of a second EMR lab with two new multi-high-frequency (8-700 GHz) heterodyne instruments for high-field measurements. EMR users also enjoyed extended frequency coverage to 1 THz and the addition of Mössbauer spectroscopy.

The NMR program continued to develop its probe expertise in 2009. Magic angle spinning triple-resonance probes were successfully tested on one of the 600 MHz instruments, laying the groundwork for development of a suite of MAS and aligned triple-resonance probes at 400, 600, and 900 MHz to be developed in 2010.

By combining NIH and ARRA funds, the Advanced Magnetic Resonance Imaging and Spectroscopy program (AMRIS) contracted in 2009 for a new console and gradients for the 11.1 T/40 cm imaging magnet and a new animal MRI system at 4.7 T/33 cm with an actively shielded magnet. The new equipment will allow AMRIS users to capitalize on state-of-the-art digital technology for pulse sequence generation and data acquisition. The addition of animal imaging and spectroscopy specialist Huadong Zeng, who joined AMRIS in late 2009, will help users get the most out of the upgraded systems.

The ICR user program added an additional pumping stage to its 14.5 T, 104 mm bore system to improve resolution of small molecules. But the biggest news by far for ICR enthusiasts was the late December award by the National Science Foundation of \$15 million to purchase a state-of-the-art, 21-T superconducting magnet system.

Magnets: making it all possible

Magnet engineers and scientists continue to create new research opportunities for Mag Lab users, and if 2009 is any indication, researchers will have a stunning array of tools to exploit over the next few years.

The design of the hotly anticipated Split-Florida Helix was completed in 2009, and fabrication has already begun. The split magnet will enable close, free-space optical access to samples at 25 T through four windows spaced evenly around the mid-plane of the magnet. This magnet will be revolutionary for optical spectroscopy at high magnetic fields.

The Magnet Lab continued to extend its lead in superconducting magnet development, with successive successful tests of yttrium barium copper oxide (YBCO) coils culminating in the October award of nearly \$3 million from NSF (to be matched with \$2 million from The Florida State University) to develop a 32 T, all-superconducting magnet. The magnet will break records for magnetic field strength and could make possible new types of science while saving vast amounts of energy and money.

The Magnet Lab continued to pursue evaluation and development of Bi-2212 in 2009, starting a new two-year collaboration among six institutions dubbed the Very High Field Superconducting Magnet Collaboration. Jointly led by Fermilab and the Magnet Lab, the collaboration will evaluate round wire Bi-2212 for high field superconducting magnets suitable for high-energy-physics applications.

Of intense interest to the user community, engineers at the Pulsed Field Facility in 2009 started development of a new insert for the 85 T pulsed magnet that is expected to allow operations in coming years at 95 T or higher in a 10 mm bore.

Also in 2009, the Magnet Lab:

- Advanced its lead in resistive-magnet development by reaching 36.2 T
- Completed the design for the Helmholtz Center Berlin series-connected hybrid magnet
- Submitted a proposal to build a 30 T superconducting magnet for the Spallation Neutron Source
- Ordered a new helium refrigerator for the Series Connected Hybrid and the 45 T hybrid.

These and many other accomplishments can be found in Chapter 4.

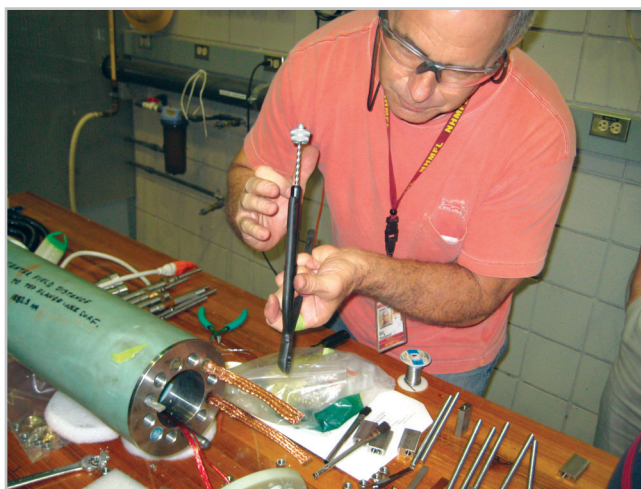

Bill Sheppard works on a YBCO coil before it's tested. The YBCO tests were so successful that the NSF awarded the Mag Lab \$3 million to build a 32-tesla all-superconducting magnet for physics research.

Mag Lab researchers honored



Scott Hannahs

Scott Hannahs, director of facilities and instrumentation for the DC Field Facility, as well as several Magnet Lab affiliates and users were named Fellows of the American Physical Society in December of 2009. Hannahs was recognized “for contributions to instrumentation and measurements in high magnetic fields and for scientific contributions to many fields including quantum fluids, organic superconductors, heavy fermions, quantum Hall effect, and Heisenberg spin systems.”

Magnet Lab-affiliated scientists from the University of Florida branch named Fellows include: **Kevin Ingersent**, **Dmitry Maslov**, and **Mark Meisel**. New APS Fellows who are users of the Magnet Lab facilities include **Raymond Ashoori**, Massachusetts Institute of Technology; **Sergey Bud’ko**, Iowa State University/Ames Laboratory; **Gang Cao**, University of Kentucky; **Junichiro Kono**, Rice University; **Jeremy Levy**, University of Pittsburgh; and **Yung Woo Park**, Seoul National University.

Vladimir Dobrosavljevic, director of the lab’s Condensed Matter Theory group and a physics professor at FSU, earned the Marko V. Jaric Prize for Outstanding Scientific Achievement in Physics. The award, the highest honor in the field of physical science in the scientist’s native Serbia, recognized Dobrosavljevic’s contribution to the development of the theory of correlated disordered electronic systems. **Alex Gurevich** and **Pedro Schlottman**, condensed matter science theorists, received Outstanding Referee awards from the APS.



Vladimir Dobrosavljevic, right, earned the Marko V. Jaric Prize for Outstanding Scientific Achievement in Physics. The award is the highest honor in the field of physical science in the scientist’s native Serbia.

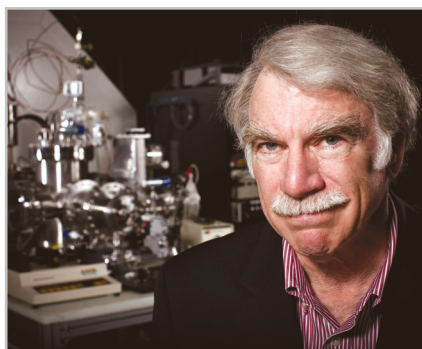

Alan G. Marshall

Continuing his run on national and international chemistry awards, ICR Program Director **Alan G. Marshall** was named co-recipient of the 2009 New Frontiers in Hydrocarbons Award sponsored by Eni, an Italian energy company. The prize recognizes “internationally significant results in the development of technologies for the efficient use of hydrocarbons with particular reference to the activities of exploration, production, transport, distribution and transformation.” Marshall, who is the Robert O. Lawton Professor of Chemistry and Biochemistry at FSU, also was named to the first group of fellows selected by the American Chemical Society.

Diversity efforts, business systems lauded

The Magnet Lab aspires to become a nationally recognized leader in the diversity of its scientific, technical, and engineering staff, much the same way it is already recognized for its education and outreach programs. With this goal in mind, the lab in 2009 conducted the following activities:

- It continued its recruiting policies of including at least one member of the Magnet Lab Diversity Committee on each search committee for scientific and technical staff, and advertised job openings in venues that target women and minorities.
- Following the recommendation from the 2008 NSF Site Visit report, the lab explored ways to establish the Dependent Care Travel Grant Program, which seeks to assist and advance the careers of underrepresented groups including women by providing grants for travel-related expenses for dependents. The Diversity Committee developed the initial proposal, and further discussions are under way with the FSU Office of Research.

- The FSU Office of Diversity & Equal Opportunity conducted a training program at the Magnet Lab, which explored the different dimensions of diversity, challenges that arise from diversity, issues that surface in diverse workgroups, and methods for handling conflict.

The lab's diversity program was just one of several subject areas reviewed during late 2008 and early 2009 as part of an NSF review of its business systems. The lab's diversity Web site was recognized as an NSF *Best Practice*, which means it exceeds the expectations of a proficient business system and should be shared with other NSF facilities. Other *Best Practices* cited by the NSF were general management, the safety awards program, the cost reduction program, the commissioning of an economic impact study, and human resources.

More information about management, administration and budget, including diversity activities, can be found in Chapter 9.

Center expands nontraditional outreach

The Lab's Center for Integrating Research & Learning launched "Doing Science Together" in 2009. Doing Science Together offers small and large groups, and kids and adults of all ages, opportunities to learn about their world with hands-on activities. CIRL partnered with Barnes & Noble booksellers for a series of Doing Science Together Nights. Including Doing Science Together, CIRL educators conducted nontraditional outreach for 750 students and parents in 2009. "Traditional" outreach was provided to 8,104 K12 students in 2009: 7,155 in classroom visits and 949 who visited the Magnet Lab in Tallahassee from 6 Florida counties: Calhoun, Columbia, Decatur, Leon, Thomas, and Wakulla. Research-experiences programs continued their tradition of excellence in 2009:

- The REU program hosted 21 undergraduate students from 13 different colleges and universities around the United States.
- The RET program hosted 13 teachers from 9 counties from South Florida to Northern Utah.

More information about CIRL highlights can be found in Chapter 6.

Over the past few years, the lab has increasingly looked for ways to engage the public by giving them more opportunities to visit the lab. On June 17, 2009, the lab launched standing public tours the third Wednesday of every month from 11:30 a .m. to 12:30 p .m. More than 90 people attended the first standing tour, with two additional tours offered afterward for those who did not arrive on time. Visitors are not required to call ahead or RSVP; they just show up. Previously, tours were only available for pre-scheduled groups of eight or greater.

Open House 2009 continued the trend of record-breaking attendance with 5,573 visitors. New for 2009 was a partnership with America's Second Harvest Food Bank of the Big Bend. Open House guests were asked to bring a canned good or other non-perishable food item as the unofficial price of admission. In all, the Magnet Lab collected more than 2,000 pounds of food. The 2009 Open House also marked the debut of the wildly popular Kids Zone, which featured demonstrations and activities for children for pre-K through 5th grade.

Mag Lab Open House 2009 by the numbers

Number of visitors	5,573
Pounds of food collected for Second Harvest Food Bank	2,021
Cups of cornstarch used in oobleck (a non-Newtonian fluid!)	1,440
Number of spectrum glasses given out for visitors to see rainbows	1,000
Number of balloons blown up in atmospheric pressure demonstration	200
Number of Peeps blown up in atmospheric pressure demonstration	150
Pounds of potatoes fired in potato cannon	100
Number of participatory science activities	75
Number of comets cooked in comet-making demonstration	35
Number of quarters shrunk in shrinking quarter machine	25
Number of Community Classroom Consortium partners participating	14

Figure 1.

Chapter 2: Research Highlights

This year's 38 highlights were selected by combing through the annual report's 416 user and faculty-submitted research reports from 17 categories representing the life sciences, chemistry, magnet science and technology and condensed matter physics.

The highlight-selection criteria emphasize research that is published, features a new technique for future users, and showcases outstanding research. Together, the highlights span all three Magnet Lab sites and seven user programs.

After we receive the reports, the lab's Science Council, composed of scientists representing all three Magnet Lab sites, reviews each report and narrows the field to a few dozen standouts. That field is then narrowed into a final list by lab Director **Greg Boebinger**.

The Science Council is made up of Chair **Albert Migliori**, and members **Rafael Brüscheiler**, **Lev Gor'kov**, **Stephen Hill**, **David Larbalestier**, **Denis Markiewicz**, **Dragana Popovic** and **Glenn Walter**.

	Reports Received	Highlights Selected
Condensed Matter Physics <i>Graphene, Basic Superconductivity, Other Condensed Matter, Qubits & Quantum Entanglement, Quantum Fluids & Solids, Condensed Matter Technique Development, Magnetism & Magnetic Materials</i>	192	19
Magnet Science & Technology <i>Applied Superconductivity, Engineering Materials, Magnet Technology</i>	57	6
Chemistry <i>Magnetic Resonance Technique Development, Geochemistry, Chemistry</i>	88	7
Life Sciences <i>Biochemistry, Biology</i>	79	6
Total	416	38

The 2009 Science and Engineering Highlights are published as Special Edition of the laboratory's magazine — *Mag Lab Reports* — and are presented in this report as representative of the lab's broad research portfolio. For more information on the scientific productivity of the Magnet Lab, including presentations and theses, see Chapter 10 of this report.

Chapter 2: Highlights TOC

CONDENSED MATTER PHYSICS

Graphene, Basic Superconductivity, Other Condensed Matter, Qubits & Quantum Entanglement, Quantum Fluids & Solids, Condensed Matter Technique Development, Magnetism & Magnetic Materials

- 10... Symmetry Breaking of the Zero Energy Landau Level in Bilayer Graphene
- 11... Many-body Instability of Coulomb Interacting Bilayer Graphene
- 12... Pronounced Half-Integer Quantum Hall Effect on Epitaxial Graphene up to 70 K
- 14... Half Integer Quantum Hall Effect in High Mobility Single Layer Epitaxial Graphene
- 15... Cyclotron Resonance at the Charge Neutral Point of Graphene
- 16... What Can We Learn from the Angle-dependence of Quantum Oscillations in $\text{YBa}_2\text{Cu}_3\text{O}_{6+x}$?
- 18... Landau Level Physics in an Underdoped High Temperature Superconductor $\text{YBa}_2\text{Cu}_3\text{O}_{6.56}$
- 19... High Field Specific Heat of Ultraclean $\text{YBCO}_{6.55}$: Coexisting Fermi Liquid and d-wave Superconducting Gap
- 20... Topological Change of the Fermi Surface in Ternary Iron Pnictides with Reduced c/a Ratio: A de Haas-van Alphen Study of CaFe_2P_2

CONDENSED MATTER PHYSICS *Continued*

- 21 ... Magnetic Ordering of the *RE* lattice in *REFeAsO*: The Odd Case of Sm. A Specific Heat Investigation in High Magnetic Field
- 22 ... Interplay of Frustration and Magnetic Field for the 2D Quantum Antiferromagnetic $\text{Cu}(\text{tn})\text{Cl}_2$
- 23 ... Magnetization Measurements of α -Uranium Using a Piezoresistive Cantilever in Pulsed Magnetic Fields
- 25 ... An Electronic Instability in Bismuth Far Beyond the Quantum Limit
- 26 ... Electrical Readout of ^{31}P Spin Qubits in Crystalline Silicon at High Magnetic Fields
- 27 ... Topological Quantum Computing with Read-Rezayi States
- 28 ... Nanodroplet Formation in Solid Solutions of Very Dilute ^3He in Solid ^4He
- 30 ... High Resolution Miniature Dilatometer Based on AFM Piezocantilever
- 31 ... First AC Heat Capacity Measurement in Capacitor-Bank-Driven Pulsed Fields
- 32 ... Decomposition Temperature of MnBi to 45 Tesla

MAGNET SCIENCE & TECHNOLOGY

Engineering materials, instrumentation, magnet technology, superconductivity-applied

- 34 ... Current Transport at Grain Boundaries in Superconducting $\text{Ba}(\text{Fe}_{1-x}\text{Co}_x)_2\text{As}_2$ Bicrystals
- 35 ... Vortex Liquid-glass Transition Up to 60 T in Nano-engineered Coated Conductors
- 37 ... Development of High Critical Current Density in Multifilamentary Round-wire $\text{Bi}_2\text{Sr}_2\text{CaCu}_2\text{O}_{8+\delta}$ by Strong Overdoping
- 38 ... *In-situ* Measurements of Magnetically Driven Motion of Specific Individual Grain Boundaries in Zn with a High Field Magnet Microscopy Probe
- 40 ... MRI Evaluation of Adsorbed Water in Solids at 21.1 T
- 41 ... Design of the NHMFL Split Resistive User Magnet for Scattering

CHEMISTRY

Chemistry, magnetic resonance techniques, geochemistry

- 43 ... High-field QCPMG NMR of Large Quadrupolar Patterns Using Resistive Magnets
- 44 ... MR Microimaging with a Cylindrical Ceramic Dielectric Resonator at 21.1 T
- 46 ... Efficient Double-resonance Coil for Low- γ MRI of Large Rodent Brains at 21.1 Tesla
- 47 ... Influence of Pb(II) Ions on the EPR Properties of the Semiquinone Radicals of Humic Acids and Model Compounds: High Field EPR and Relativistic DFT Studies
- 49 ... High-Field EPR and Magnetic Susceptibility Studies on Tetranuclear Ferromagnetic Quinoline Adducts of Copper(II) Trifluoroacetate
- 50 ... Chemical Speciation of Calcium and Sodium Naphthenate Deposits by Electrospray Ionization FT-ICR Mass Spectrometry
- 52 ... A Robust 2-Dimensional Separation for Top-Down Tandem Mass Spectrometry of the Low Mass Proteome

LIFE SCIENCES

Biochemistry and biology

- 54 ... Solid-State ^{35}Cl NMR Spectroscopy of a Variety of Hydrochloride Pharmaceuticals
- 55 ... Exploiting Marine Cyanobacteria for Drug Discovery
- 57 ... KIT Kinase Mutants Show Novel Mechanisms of Drug Resistance to Imatinib and Sunitinib in Gastrointestinal Stromal Tumor Patients
- 58 ... *In vivo* Sodium and Proton MR Imaging of Large Rodents at 21.1 T
- 60 ... A Novel Approach to Dementia: High Resolution ^1H MRI of the Human Hippocampus at 21.1 T
- 61 ... MR Microscopy of Nerve Fiber Structure at the Cellular Level; Validation of Tractography

Understanding of the novel quantum Hall effect in graphene, especially the behavior at the charge neutral point where the density of states vanishes at zero field, remains an active area of research. Earlier transport studies in single layer graphene have shown that high magnetic fields lift the unusual fourfold degeneracy of the zero-energy Landau level (LL) and lead to the formation of a gapped state. In bilayer graphene, on the other hand, the zero-energy LL has an eightfold degeneracy. This report describes transport measurements on bilayer graphene on a SiO_2 substrate, which demonstrate that high magnetic fields completely lift the degeneracy and lead to the insulating behavior at the charge neutral point, similar to the results on single layer graphene. Although the data suggest that electron-electron interactions might be responsible for the lifting of the degeneracy, the origin of this symmetry breaking in bilayer graphene is still unknown and more studies are sure to follow.

• This work was published in *Phys. Rev. Lett.*, 104, 066801 (2010).

Symmetry Breaking of the Zero Energy Landau Level in Bilayer Graphene

Y. Zhao (Columbia University, Physics); P. Cadden-Zimansky (Columbia University, Physics & Magnet Lab); Z. Jiang (Georgia Institute of Technology, Physics); and P. Kim (Columbia University, Physics)

INTRODUCTION

Its hybrid linear-parabolic band structure and the associated 2π Berry phase of its charge carriers make the physics of bilayer graphene as distinct from monolayer graphene as the latter is from conventional two-dimensional electron systems. In particular, these properties lead to the formation of an unprecedented eightfold degenerate Landau level (LL) that forms at the charge neutral crossover point under sufficiently high magnetic fields. This degeneracy has previously been detected by observing the formation of successive quantum Hall plateaus at $\nu=-4$ and $\nu=4$ filling factors.

EXPERIMENT RESULTS

By subjecting high mobility bilayer graphene (lower inset Figure 1) to magnetic fields in excess of 25 tesla (T), the complete lifting of this eightfold degenerate LL can be observed¹. As shown in Figure 1, the Hall conductance at the lowest field displays the $\nu=-4$ and $\nu=4$ filling factors that mark the initial degeneracy. As the field is increased, new plateaus emerge as successive symmetries are broken, with plateaus eventually appearing at each filling factor.

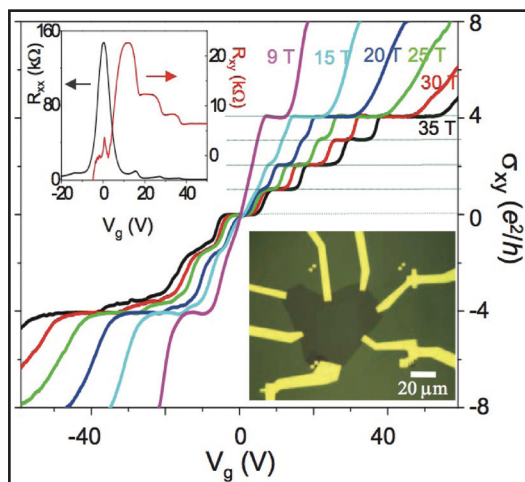

Figure 1

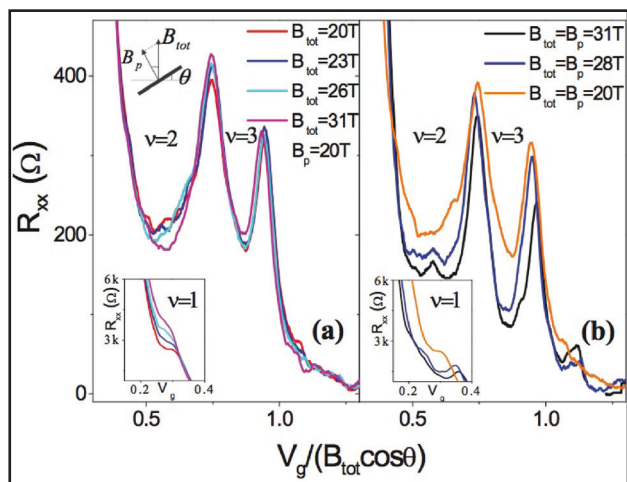

Figure 2

These new filling factors also can be detected through the measurement of new resistance minima in the longitudinal resistance. By examining the behavior of these minima as the magnitude and direction of the applied field is changed, information about the origin of the symmetry breaking that underlies each new plateau can be gained. In particular, the sensitivity of the minima at $\nu=2$ & 3 to the perpendicular component of the applied field rather than to the total field (Figure 2) indicates that these states are not formed by conventional Zeeman splitting.

ACKNOWLEDGEMENTS

This work is supported by the DOE (No. DE-FG02-05ER46215).

REFERENCES

1. Zhao, Y., *et al.*, *Phys. Rev. Lett.*, **104**, 066801 (2010).

Low-energy electronic structure of bilayer graphene is made of two Fermi points with quadratic dispersions. Using renormalization group (RG) theory to study low-energy properties, we find that the two quadratic Fermi points spontaneously split into four Dirac points at zero temperature. This results in a nematic state that spontaneously breaks the sixfold lattice rotation symmetry into a twofold one, with a finite transition temperature. Critical properties of the transition and effects of trigonal warping are also discussed.

• This work was published in *Phys. Rev. B Rapid Commun.*, **81** (4), 041401 R (2010).

Many-body Instability of Coulomb Interacting Bilayer Graphene

Oskar Vafek, Kun Yang (FSU/Magnet Lab)

INTRODUCTION

Low-energy electronic structure of (unbiased) bilayer graphene is made of two Fermi points with quadratic dispersions, if trigonal-warping and other high order contributions are ignored. We show that as a result of this qualitative difference from single-layer graphene, short-range (or screened Coulomb) interactions are marginally relevant. We use RG to study their effects on low-energy properties of the system, and show that the two quadratic Fermi points spontaneously split into four Dirac points at zero temperature. This results in a nematic state that spontaneously breaks the sixfold lattice rotation symmetry (combined with layer permutation) down to a twofold one, with a finite transition temperature. Critical properties of the transition and effects of trigonal warping are also discussed.

RESULTS AND DISCUSSION

In this work we apply the RG method to the bilayer graphene with Bernal stacking. While in general, the motion of the non-interacting electrons in such potential does not lead to diverging susceptibilities since the energy spectrum has two sets of four Dirac points in the corners of the Brillouin zone (due to trigonal warping), if only nearest neighbor hopping is considered, each set of four Dirac points merges into a single degenerate point with parabolic dispersion. As the nearest neighbor hopping amplitudes are the largest, the latter is the natural starting point of theoretical analysis.

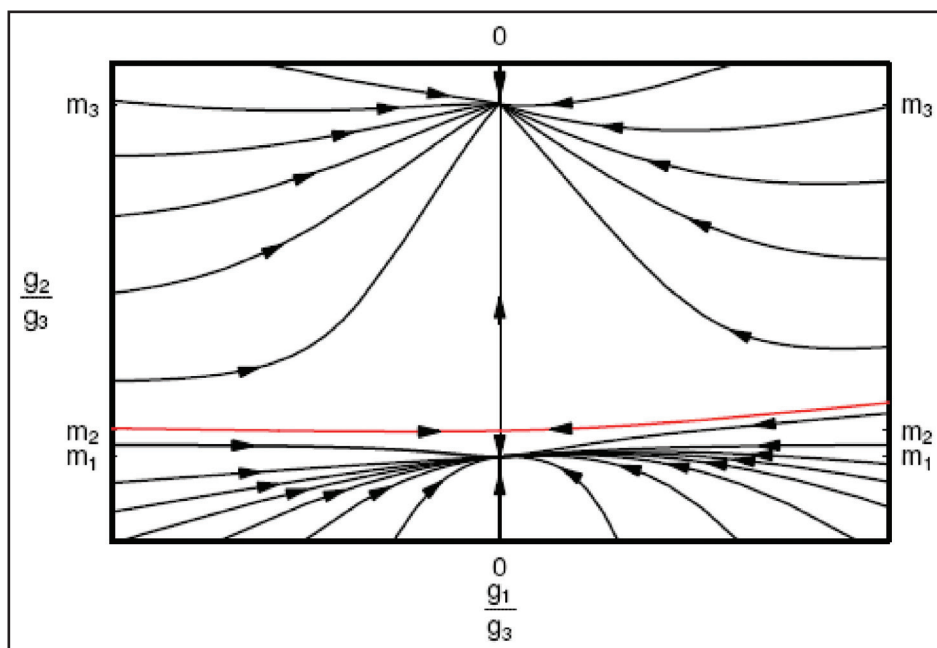

Next, we develop the effective theory for the low energy degrees of freedom, finding that if we start with the interaction in the density-density channel only, two additional coupling constants are generated. We therefore track the RG flow of the three coupling constants to find that they all diverge at a specific energy scale, which we associate with the transition temperature. While all three couplings diverge, their ratios flow to non-trivial (universal) numbers shown in the figure below.

The solution of the RG flow equations allows us to analyze the flow of the susceptibilities toward various broken symmetry states. We find the susceptibilities in 15 particle-hole channels and 16 particle-particle channels to find that the most divergent one is the nematic channel.

CONCLUSIONS

This leads us to the interesting conclusion that at low enough temperature, the Coulomb interactions lead to the electronic nematic state via a continuous phase transition. This state breaks the threefold rotational symmetry, but does not break the (lattice) translational symmetry, making it distinct from stripes. Moreover, while in the continuum approximation the transition would be of Kostrelitz-Thouless type (infinite order) the presence of the threefold symmetry allows for a third-order order parameter invariant. This puts the transition in the universality class of the 3-state Potts model, i.e. the transition remains continuous despite being first order within the mean-field approximation.

REFERENCES

1. Vafek, O. and Yang, K., *Phys. Rev. B Rapid Commun.*, **81** (4), 041401 R (2010).

The remarkable properties of epitaxial graphene (EG) grown on silicon carbide have made it a promising platform for graphene-based electronics. An interesting question that remained to be addressed is whether the electrical properties of epitaxial graphene on SiC are essentially the same as those in exfoliated graphene films, where the observation of the quantum Hall effect (QHE) was pivotal for graphene research. The group from Purdue examined gated, few-layer EG films grown on the Si-face of 4H SiC substrates. They observed well-defined QHE that reproduces the unique features exhibited by exfoliated single-layer graphene, including a Berry phase of π . The electrical properties of films were retained after gate stack formation without significant degradation. The user group from Georgia Tech studied a high-mobility single graphene layer grown on the C-face of the same substrate. The mobility was comparable to the best exfoliated graphene flakes and an order of magnitude larger than Si-face EG monolayers. The group demonstrated the characteristic QHE with a Berry phase of π . The researchers have also shown that QHE is insensitive to processing induced disorder. These important experiments bring epitaxial graphene yet a step closer to becoming a scalable platform for graphene-based electronics.

Pronounced Half-Integer Quantum Hall Effect on Epitaxial Graphene up to 70 K

Tian Shen, Adam T. Neal, Jiangjiang Gu, Min Xu, Yanqing Wu, Mike Bolen, Michael A. Capano, and Peide D. Ye (Purdue University, Electrical and Computer Engineering); Lloyd Engel (MagnetLab)

INTRODUCTION

Recent reports of large-area epitaxial graphene by thermal decomposition of SiC wafers have provided the missing pathway to a viable electronics technology.¹⁻⁵ An interesting question that remains to be addressed is whether the electrical properties of epitaxial graphene on SiC are essentially same as those in exfoliated graphene films.⁵⁻⁷ For example, the well-known quantum Hall effect (QHE), a distinguishing feature of a two-dimensional electronic material system, is just beginning to be discovered in epitaxial graphene.⁸⁻¹⁰ We report on the observation of the QHE in gated epitaxial graphene films on SiC (0001), along with pronounced Shubnikov-de Haas (SdH) oscillations in magneto-transport. The last QH plateau is especially pronounced, even at temperatures as high as 70 K, reaching the temperature limit of the present experimental setup.

RESULTS AND DISCUSSION

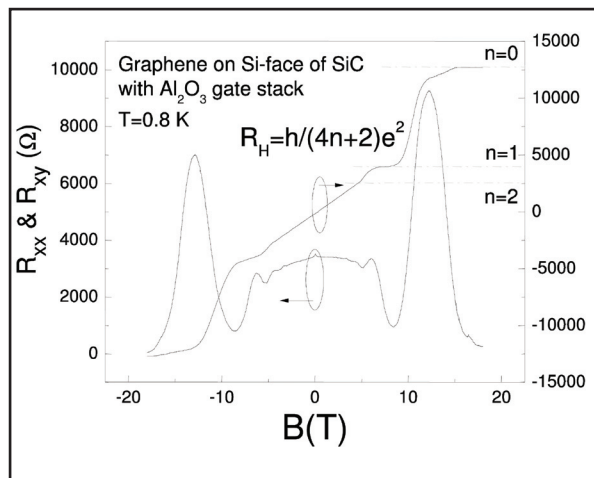

Figure 1

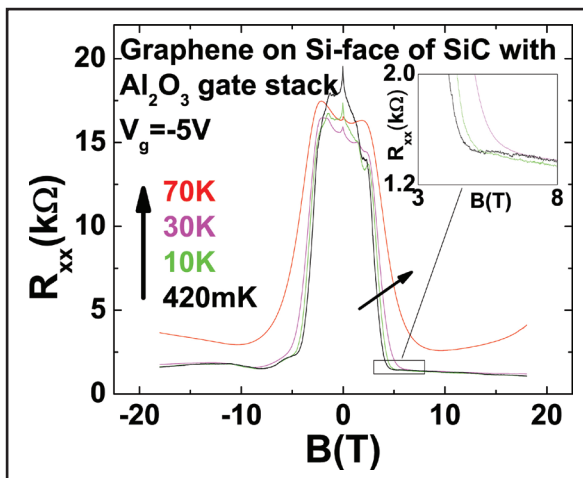

Figure 2

Figure 1 shows the Hall resistance and magneto-resistance measured at $T=0.8$ K with floating gate bias. The horizontal dashed lines correspond to $h/(4n+2)e^2$ values. The QHE of the electron gas in epitaxial graphene shows one quantized plateau and two developing plateau in R_{xy} with vanishing R_{xx} in the corresponding magnetic field regime. Figure 2 shows the temperature dependence of R_{xx} at $V_g = -5$ V. Pronounced SdH minimum remain up to 70 K. Figure 3 shows the temperature dependence of R_{xy} at $V_g = -5$ V. A pronounced $n=0$ QH plateau remains up to 70 K. Experiments were performed using SCM-2 at the Magnet Lab's Tallahassee, FL, headquarters.

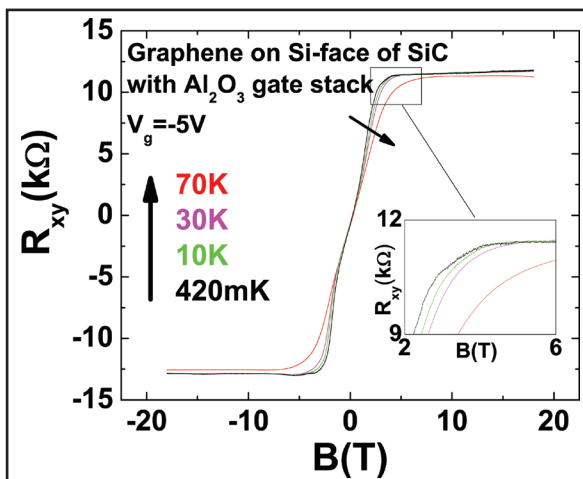

Figure 3

CONCLUSIONS

In conclusion, a high- k gate stack on epitaxial graphene is realized by inserting a fully oxidized nanometer thin aluminum film as a seeding layer followed by an atomic-layer deposition process. The electrical properties of epitaxial graphene films are sustained after gate stack formation without significant degradation. At low temperatures, the QHE is observed in epitaxial graphene on SiC (0001), along with pronounced SdH oscillations. This quantum experiment confirms that epitaxial graphene on SiC (0001) shares the same relativistic physics as the exfoliated graphene.

ACKNOWLEDGEMENTS

The authors would like to thank J.A. Cooper Jr. and L.P. Rokhinson for valuable discussions, and G. Jones, T. Murphy and E. Palm at the Magnet Lab for experimental assistance. Part of the work on graphene is supported by Nanoelectronics Research Initiative through Midwest Institute of Nanoelectronics Discovery, DARPA and Intel Corp. The Magnet Lab is supported by NSF Grant Nos. DMR-0084173 and ECS-0348289, the state of Florida, and DOE.

REFERENCES

1. Y.Q. Wu, *et al.*, *Appl. Phys. Lett.*, **92**, 092102 (2008).
2. G. Gu, *et al.*, *Appl. Phys. Lett.*, **90**, 253507 (2007).
3. J.S. Moon, *et al.*, *IEEE EDL*, **30**, 650 (2009).
4. J. Kedzierski, *et al.*, *IEEE TED*, **55**, 2078 (2008).
5. C. Berger, *et al.*, *Science*, **312**, 1191 (2006).
6. K.S. Novoselov, *et al.*, *Science*, **306**, 666 (2004).
7. Y. Zhang, *et al.*, *Nature*, **438**, 201 (2005).
8. T. Shen, *et al.*, *Appl. Phys. Lett.*, **95**, 172105 (2009).
9. J. Jobst, *et al.*, arXiv:0908.1900v1.
10. X. Wu, *et al.*, arXiv:0908.4112.

Half Integer Quantum Hall Effect in High Mobility Single Layer Epitaxial Graphene

Xiasong Wu (Georgia Tech), Yike Hu (Georgia Tech), Claire Berger (CNRS & Georgia Tech), Walt de Heer (Georgia Tech)

INTRODUCTION

The remarkable properties of epitaxial graphene (EG) grown on silicon carbide, like its high mobility and graphene electronic structure¹ and the fact that it can be patterned, have made it a promising platform for graphene-based electronics². However, the quantum Hall effect (QHE) was elusive. The observation of the anomalous QHE in microscopic exfoliated graphene flakes that were deposited on silicon oxide substrates³ was pivotal for graphene research. Its absence in EG led to speculations about the quality of EG and the effect of the silicon carbide substrate on transport. The demonstration of the QHE in the present experiment⁴ in patterned EG is an important milestone in graphene science.

EXPERIMENTAL

An EG monolayer was grown on a semi-insulating silicon carbide substrate² and characterized by atomic force microscopy, ellipsometry and Raman spectroscopy. The EG layer was electron-beam patterned to produce a Hall bar structure and metal contact pads were applied. The SCM2 facility at the Magnet Lab was used. Transport (longitudinal and transverse – Hall - resistance) measurements were performed up to 18 tesla (T) at 4 K. The charge density was controlled by adjusting the exposure to humidity as well as by exposure to ambient light.

RESULTS AND DISCUSSION

From the transport data, the mobility of the sample is 20,000 cm²/V·s. The high-field experiment shows a well resolved QHE (see Figure): quantum Hall plateaus are observed in the magnetic field dependence of the Hall resistance. The Hall plateaus correspond to transverse resistances $\rho_{xy} = (h/4e^2) / (n+1/2)$ for $n=0$ to 3, where n is the Landau level index, which establishes the nontrivial Berry's phase of π . The longitudinal resistivity ρ_{xx} shows the characteristic Shubnikov-de Haas oscillations, in which Landau levels from $n=0$ up to $n=7$ are easily recognized. The oscillations develop into the QHE in high fields, manifested by characteristic zero resistance minima and Hall plateaus. Despite the fact that the graphene is draped over several SiC steps, is heavily contaminated and has pleats (see AFM image in the figure inset), the mobility is high and the anomalous QHE is unambiguously observed.

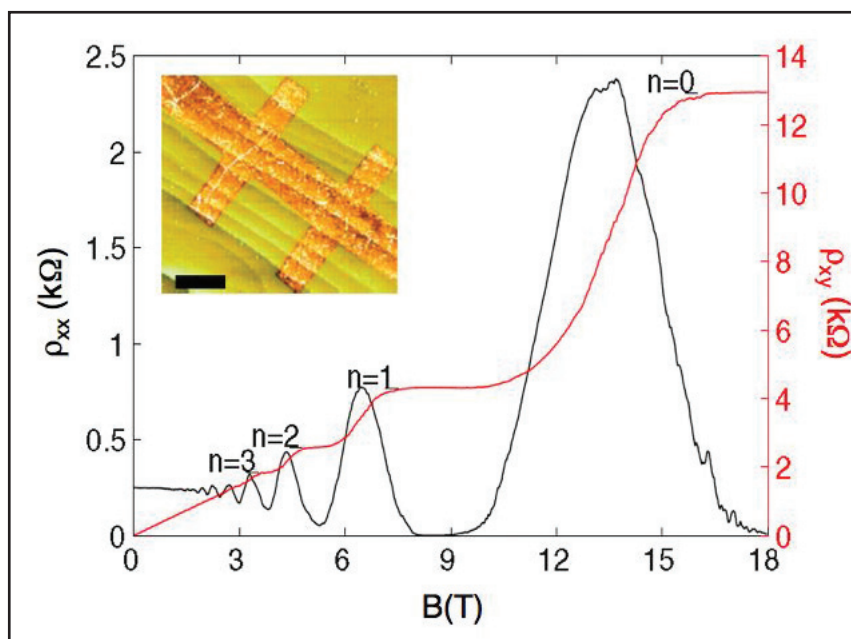

Figure 1. Quantum Hall effect in single layer epitaxial graphene. Inset AFM image of the patterned graphene draping over the SiC steps.

CONCLUSIONS

The quantum Hall effect, with a Berry's phase of π is demonstrated for the first time on a single graphene layer grown on the C-face of 4H silicon carbide. The mobility (20,000 $\text{cm}^2/\text{V}\cdot\text{s}$ at 4 K) is comparable to the best exfoliated graphene flakes on SiO_2 and an order of magnitude larger than Si-face epitaxial graphene monolayers. We have also shown that QHE is insensitive to processing induced disorder. These results and other properties indicate that C-face epitaxial graphene is an ideal platform for graphene-based electronics.

ACKNOWLEDGEMENTS

This work was supported by NSF under Grant No. DMR-0820382 and the W. M. Keck Foundation. We thank Z. G. Jiang for insightful discussions, and acknowledge E. C. Palm, T. P. Murphy, J.-H. Park, G. E. Jones for experimental assistance.

REFERENCES

1. Berger, C., *et al.*, *Science*, **3012**, 1191 (2006).
2. Berger, C., *et al.*, *J. Phys. Chem. B*, **108**, 19912 (2004).
3. Zhang, Y. B., *et al.*, *Nature*, **438**, 201 (2005).

High magnetic fields lift the fourfold degeneracy of the zero-energy Landau level (LL) in single layer graphene and lead to the formation of a gapped state. The precise mechanism has been a subject of intense theoretical study, with electron-electron interactions expected to play a critical role. Since transport measurements are not suitable for detailed studies of a gapped state, the authors of this report have utilized infrared magnetospectroscopy to investigate the zero-energy LL in monolayer graphene on a SiO_2 substrate. This technique is sensitive to the cyclotron orbits of charge carriers that form throughout the entire graphene sheet. Unexpected and sizable shifts in the cyclotron resonance (CR) transition energies are observed as a function of the LL filling factor and applied field. The shifts are attributed to electron-electron interactions that nucleate a gap in the $n = 0$ LL, thereby affecting the energies of CR transitions to and from this level.

• This work was published in *Phys. Rev. Lett.*, **104** (6), 067404 (2010).

Cyclotron Resonance at the Charge Neutral Point of Graphene

E. A. Henriksen (Columbia University, Physics), P. Cadden-Zimansky (Columbia University, Physics & Magnet Lab), Z. Jiang (Georgia Institute of Technology, Physics), Z. Q. Li (Columbia University), L.-C. Tung (Magnet Lab), M. E. Schwartz (Columbia University, Physics), M. Takita (Barnard College, Physics), Y.-J. Wang (Magnet Lab), P. Kim (Columbia University, Physics), and H. L. Stormer (Columbia University, Physics & Applied Physics & Alcatel-Lucent)

INTRODUCTION

One of the central problems of graphene is gaining an understanding of its electronic behavior at the charge neutral point (CNP), where the density of states vanishes at zero field, a unique particle-hole symmetric LL forms at moderate fields, and a divergent longitudinal resistance is observed at high fields. The divergent resistance precludes a conventional characterization of the unique "n=0" LL using standard transport techniques, but this level is amenable to study through CR transitions into and out of it that are observed by infrared (IR) spectroscopy.

EXPERIMENTAL RESULTS

By examining IR absorption of graphene at high fields while its Fermi level is tuned through the CNP, the energy of the CR transitions into and out of the $n=0$ LL can be seen directly. While a single-electron picture of transitions between degenerate LLs predicts a constant CR energy, large shifts upward, as high as 20 meV, are invariably seen in the resonance energy at the CNP¹. The field dependence of these shifts, and the lack of such shifts in the interband CR transitions that do not involve the $n=0$ LL, suggest that a high-field energy gap may form at the CNP (Figure 1). As the novel linear dispersion relation of the charge carriers in graphene renders Kohn's theorem (which states that CR is insensitive to electron-electron interactions) inapplicable, detailed mapping of these shifts (Figure 2) has the potential to reveal underlying many body effects.

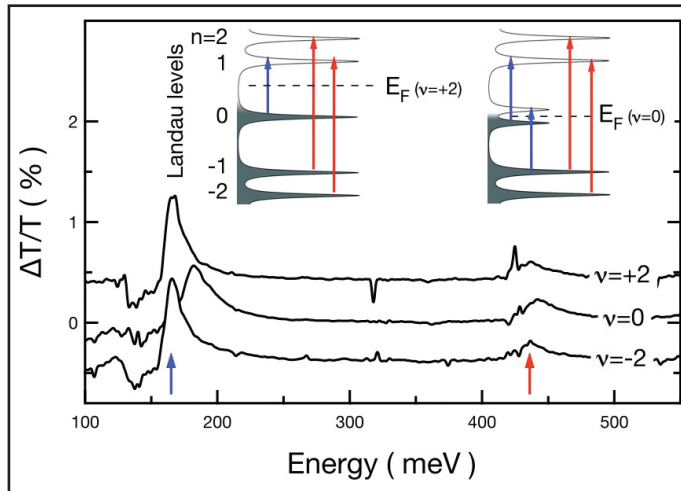

Figure 1

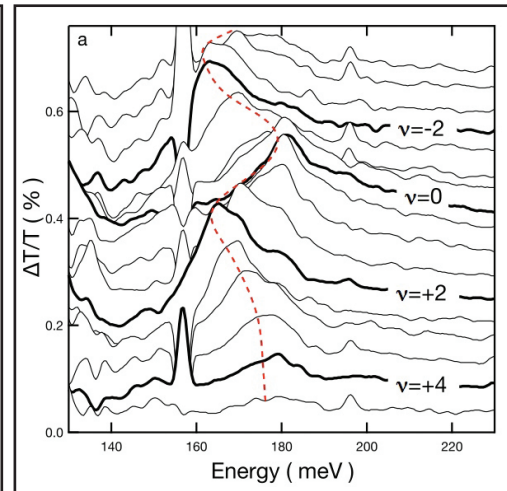

Figure 2

ACKNOWLEDGEMENTS

This work is supported by the DOE (DE-AIO2-04ER46133, DE-FG02-05ER46215 and DE-FG02-07ER46451), the NSF under DMR-03-52738, CHE-0117752, and DMR-0820382, ONR (N000150610138), NYSTAR, the Keck Foundation, Microsoft Project-Q, and the SRC-NRI-MIND.

REFERENCES

1. Henriksen, E., *et al.*, *Phys. Rev. Lett.*, **104** (6), 067404 (2010).

Two noteworthy reports come from one and the same group of the authors using the contactless conductivity method for observation of quantum oscillations (QO). Among the findings are: the shape of the Fermi surface as deduced from the angular dependence of the QO-oscillation frequency; the angular variation of the effective mass; and the Lifshitz-Kosevitch form of the oscillations. Results from P. Goddard *et al.* include the observation of corrugations of the Fermi surface (FS) cylinder caused by the perpendicular-to-plane tunneling. Additional analysis of data by S. Sebastian *et al.* shows the applicability of the Landau Fermi liquid concept.

What Can We Learn from the Angle-dependence of Quantum Oscillations in $\text{YBa}_2\text{Cu}_3\text{O}_{6+x}$?

P. A. Goddard (University of Oxford); Suchitra Sebastian (University of Cambridge); N. Harrison (Magnet Lab-LANL); M. M. Altarawneh (Magnet Lab-LANL); C. H. Mielke (Magnet Lab-LANL); Ruixing Liang (University of British Columbia); D. A. Bonn (University of British Columbia); W. N. Hardy (University of British Columbia) and G. G. Lonzarich (University of Cambridge)

Two-axis rotation in fixed magnetic fields is a powerful tool for investigating the topology of low-dimensional Fermi surfaces. In particular, for highly anisotropic materials, measuring the resistivity while rotating the sample in an applied magnetic field is often the only technique that can deliver information on the Fermi surface (FS) shape and the nature of the inter-plane transport in the bulk of the material.

In low-dimensional metallic systems the FS is usually made up of quasi-one-dimensional (Q1D) sheets and/or quasi-two-dimensional (Q2D) cylinders with a slight warping due to the interlayer electronic transfer. Magnetic quantum oscillations (QOs) are sensitive to closed quasiparticle orbits on the Q2D FS sections and can be used to determine the cross-sectional area of these pockets perpendicular to the applied magnetic field, as well as providing information regarding the effective masses and scattering rates¹. However, when the warping of the FS is very small it is difficult, sometimes impossible, to extract information regarding the *shape* of the pockets from an angle-dependence of the QOs. This is because the change in frequency of the QOs on rotation will be determined solely by the cosine of the angle between the cylinder axis and the magnetic field, no matter what shape the footprint of the Q2D FS might be. These restrictions are relaxed when the warping of the FS is larger in magnitude than the separation between Landau levels. At the fields at which this is true, it should, in principle, be possible not only to resolve separate QOs for the so-called neck and belly orbits (originating from the narrowest and widest cross-sections of the FS), but also

to deduce information regarding the in-plane footprint of the FS from the deviations of the QOs from the simple cosine angular-dependence^{2,3}. We have attempted to look for signatures of such warping in a number of unconventional superconductors. Here we present preliminary data for $\text{YBa}_2\text{Cu}_3\text{O}_{6+x}$ for two compositions: $x = 0.54$ and 0.56 .

The samples were prepared at the University of British Columbia. The QOs were detected using the contactless conductivity method, which is sensitive to changes in skin depth via changes (Δf) in frequency of a resonant circuit⁴. These studies take place at low temperatures in order to maximize the amplitude of the QOs. High fields are required to overcome the robust superconductivity displayed by the materials and allow the QOs to be seen. Fixed fields are necessary for continuous angular rotation. For these reasons the 45-tesla hybrid magnet at the Magnet Lab in Tallahassee is the only place in the world that experiments like these can be performed.

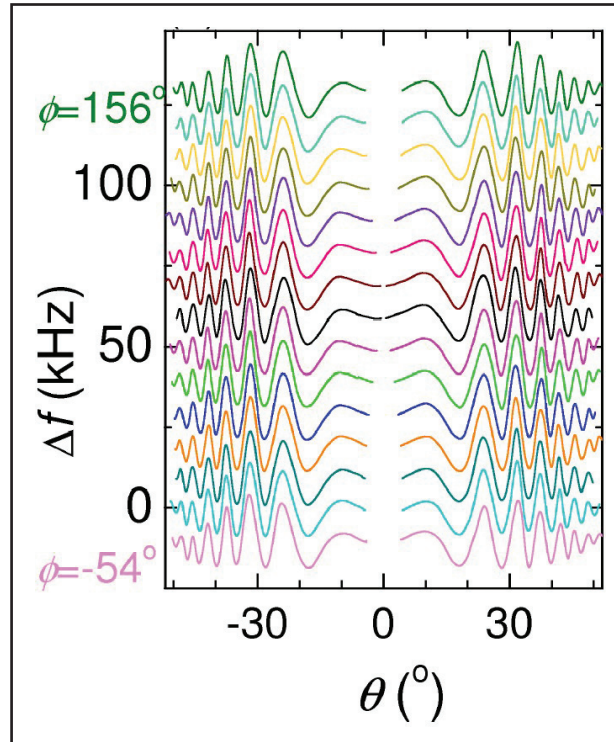

The figure shows angle-dependent quantum-oscillation data in $\text{YBa}_2\text{Cu}_3\text{O}_{6.56}$ taken in the hybrid magnet at a field of 45 T and a temperature of 1.5 K and after a background has been subtracted. θ is the angle between the c -axis and the magnetic field. ϕ is the azimuthal angle of rotation and runs in 15° steps from -54° to 154° (bottom to top). A complete angle-dependence was undertaken. The gaps in the data result from a correction for a sample misalignment of $\sim 7^\circ$. Because of the size of the interlayer transfer, the effect we are looking for in $\text{YBa}_2\text{Cu}_3\text{O}_{6+x}$ is subtle, but a preliminary analysis of the angle-dependent data suggest that at least one Q2D FS section is detected that has a small but measurable warping and a footprint that deviates from simple circular symmetry. These results have been accepted for publication as an Editors' Suggestion in *Physical Review B*.

ACKNOWLEDGEMENTS

We acknowledge the support of the U.S. Department of Energy, the National Science Foundation, the state of Florida, the Royal Society, Trinity College (University of Cambridge), and the UK Engineering and Physical Sciences Research Council.

REFERENCES

1. Shoenberg, D., *Magnetic oscillations in metals* (Cambridge University Press 1984).
2. Harrison, N. and McDonald R. D., *J. Phys.: Condens. Matt.*, **21**, 192201 (2009).
3. Wosnitza, J., *Int. J. Mod. Phys. B*, **7**, 2707-2741 (1993).
4. Altarawneh, M. M., et al., *Rev. Sci. Instr.*, **80**, 066104 (2009).

Landau Level Physics in an Underdoped High Temperature Superconductor $\text{YBa}_2\text{Cu}_3\text{O}_{6.56}$

Suchitra E. Sebastian, G. G. Lonzarich (U. of Cambridge), Moaz Altarawneh, Chuck Mielke, Neil Harrison (Magnet Lab-LANL), D. A. Bonn, Ruixing Liang, W. N. Hardy (U. of British Columbia)

INTRODUCTION

For the two decades since the discovery of high T_c cuprate, physicists have been perplexed as to the mechanism of superconductivity that's unconventional in its origin and in its surprisingly high value. It is believed that the strange properties of the "normal" state out of which superconductivity originates may hold the key to this mystery. Indeed, experiments such as photoemission and transport have probed the high-energy and high-temperature properties of the quasiparticles that precede Cooper pairing in high T_c cuprates, yielding peculiar properties that do not correspond to those of a conventional Fermi liquid.

For the first time, quantum-oscillation measurements in ultra-high magnetic fields have been able to probe the low energy properties of normal quasiparticles in cuprate superconductors by suppressing the superconducting dome. We are able to probe these low-energy properties and compare them with conventional Landau quasiparticles to understand whether in fact the Fermi liquid picture completely breaks down in underdoped cuprates. Here we present results of low temperature dependent quantum-oscillation amplitude measurements in a portable dilution fridge in the 45 tesla (T) hybrid magnet, and angular-dependent quantum-oscillation frequency and effective mass measurements in order to compare these with conventional Fermi metal behavior.

EXPERIMENTAL

The quantum-oscillation amplitude we measure down to temperatures of 100 mK (figure on right) at 45 T is seen to saturate at the lowest temperatures as expected for standard Fermi liquid behavior, in which the Lifshitz-Kosevich form is obeyed. Remarkably we find that this strongly correlated system $\text{YBa}_2\text{Cu}_3\text{O}_{6.56}$ instead of contravening Fermi Dirac statistics, in fact obeys them exactly as expected.

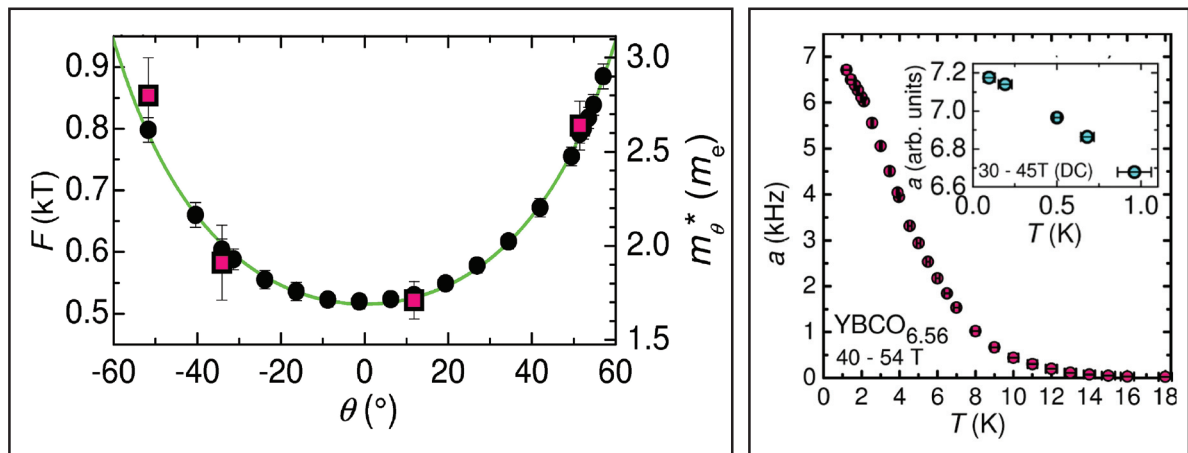

The predominant quantum-oscillation frequency and effective mass are shown as a function of the angle of inclination of the magnetic field to the crystalline c -axis (θ) in the figure on the left. Here too we see that exactly as expected for the extremal Fermi surface orbits in a conventional layered system, a Cosine dependence (green line) is followed both by the frequency and effective mass of a single orbit.

RESULTS AND DISCUSSION

Low-temperature measurements in ultra-high magnetic fields enabled at the Magnet Lab have begun to overturn conventional wisdom in the underdoped cuprates that has perhaps stalled progress in this field for almost two decades. These quantum-oscillation measurements may indeed pave the way to the ultimate breakthrough in understanding unconventional superconductivity in these materials.

REFERENCES

1. Sebastian, S. E., *et al.*, <http://arxiv.org/abs/0912.3022> (2009).
2. Sebastian, S. E., *et al.*, *Phys. Rev. Lett.*, **103**, 256405 (2009).

The report of S. Riggs *et al.* features the first ever measurements of the specific heat of underdoped YBCO_{6.55} in high magnetic fields up to 45 tesla (T) and T~10 K that showed the remarkable square-root dependence of the magnetic specific heat, $B^{1/2}$, on the magnetic field. G. Volovik predicted this specific behavior for a system of vortices in superconductors with a d-wave order parameter in 1993. The authors claim that the dependence survives above T_c giving support to the idea of pre-formed pairs. Quantum oscillations for the specific heat are seen for the first time in the presence of this background and interpreted qualitatively in the framework of the Lifshitz-Kosevich theory.

High Field Specific Heat of Ultraclean YBCO_{6.55}: Coexisting Fermi Liquid and d-wave Superconducting Gap

Scott Riggs (FSU, Mag Lab); Oskar Vafeek (FSU, Mag Lab); Jon Kemper (FSU, Mag Lab); Greg Boebinger (FSU, Mag Lab); Jon Betts (LANL, Mag Lab); Albert Migliori (LANL, Mag Lab); Doug Bonn (UBC); Walter Hardy (UBC); Ruixing Liang (UBC)

INTRODUCTION

The true nature of the magnetic-field-induced resistive normal state in high temperature superconductivity (HTc) remains a mystery. There are two prominent schools of thought. One is that the application of magnetic field destroys the d-wave superconducting gap to uncover a competing state with low energy Fermionic degrees of freedom. The other is that an applied magnetic field destroys long-range phase coherence but local superconductivity survives. By measuring the specific heat, a bulk thermodynamic probe on ultra-clean YBaCuO_{6.55} we determine the field evolution of the quasi-particle density of states well into the magnetic-field-induced normal state and find co-existence of both phases. At high fields the specific heat as a function of temperature follows the conventional form expected for a Fermi Liquid; $\frac{C}{T} = \gamma T + \beta T^3$. On the other hand the field evolution of the electronic quasi-particle density of states follows a sqrt(H) behavior through the entire magnetic field range measured, evidencing a fully developed d-wave gap. From the very small value of the specific heat in the zero-temperature limit, we conclude that the Fermi liquid phenomena arise from a single pocket of carriers that coexists with d-wave superconductivity in the copper-oxygen planes. The d-wave superconducting gap persists to at least 45 T magnetic fields, which is *twice* the magnetic field, H_{irr} , at which the resistive transition occurs.

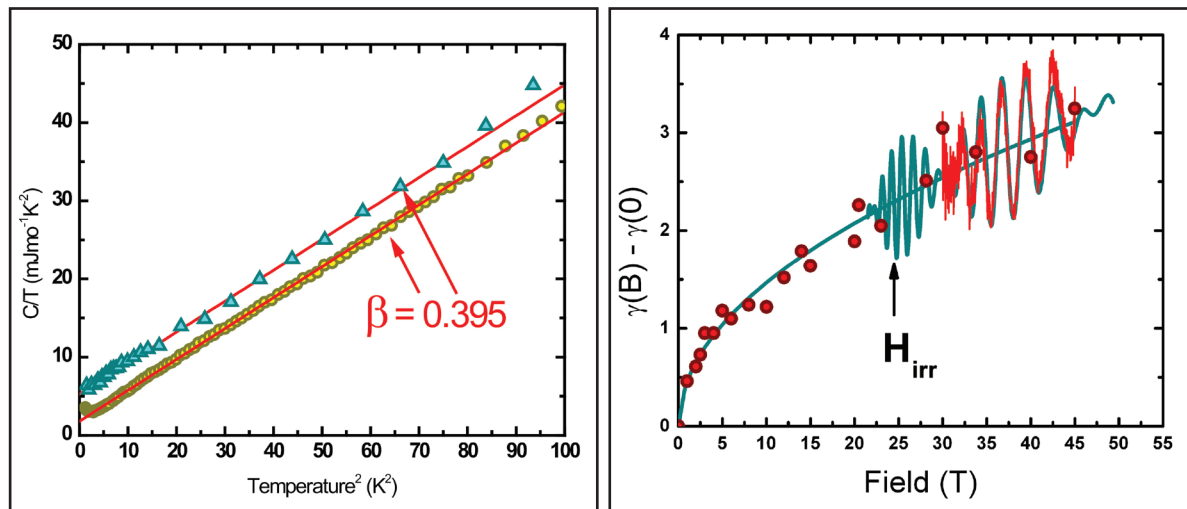

Figure 1.

Left hand panel plots the specific heat divided by temperature as a function of K^2 for 0T (yellow circles) and 45T (blue triangles). Both field values follow the normal Fermi liquid form and give the same slope value for the phonons, establishing β as a field independent quantity. The right hand panel plots the electronic contribution to the specific heat of YBCO_{6.55} as a function of magnetic field. The data show quantum oscillations (red) consistent with a Fermi liquid (blue oscillations are a fit to the data). The data also show a sqrt(H) dependence up to the highest fields measured, establishing the persistence of a fully developed superconducting d-wave gap up to our highest fields measured.

In 2009 there were numerous studies of the iron pnictides, recently discovered materials with rather high T_c (up to 50 K in some materials). The report of A. Coldea *et al.* deserves recognition: the non-superconducting material CaFe_2P_2 has the crystalline parameters close to the ones of the so-called collapsed tetragonal (CT) phase of CaFe_2As_2 that sets in under high pressure. The dHvA experiments revealed the strongly three-dimensional Fermi surface in CaFe_2P_2 . The outcome is that nesting features/congruency between the two-dimensional electron and hole Fermi surfaces seem to play the essential role in the magnetic, structural and superconducting properties of most of the HTcS iron pnictides.

• This work was published in *Phys. Rev. Lett.*, **103**, 026404 (2009).

Topological Change of the Fermi Surface in Ternary Iron Pnictides with Reduced c/a Ratio: A de Haas–van Alphen Study of CaFe_2P_2

Amalia I. Coldea, C. M. Andrew, A. F. Bangura, A. Carrington (Bristol University, UK); J. G. Analytis, J.-H. Chu, I. R. Fisher (Stanford University); R. D. McDonald (Magnet Lab-LANL)

The superconductivity in iron pnictides can be induced either by doping, applied pressure or isoelectronic substitution. The isoelectronic substitution of pnictogen (As with P) does not change the number of Fe 3d electrons but acts like applying chemical pressure, which is equivalent to applied hydrostatic pressure. This is for example the case of CaFe_2P_2 , which is a very close structural analogue of the collapsed tetragonal phase (CT) phase of CaFe_2As_2 , which occurs on applying pressure¹. Yildirim has argued that the CT phase of CaFe_2As_2 occurs when, by reducing the Fe moment, the Fe-As bonding weakens and the (inter and intraplanar) As-As bonding gets stronger causing the significant strong reduction in the c axis². Similarly, in nonmagnetic phosphides, the reduction in the c axis (or the c/a ratio) results in an increase P-P hybridization between pnictogen ions along the c direction (close to the single bond distance). Consequently the interlayer P-P distance approaches the molecular bond length, just as the As-As distance does in the CT phase. The spacer between the iron layers (Sr or Ba) limits the degree of this hybridization between layers and such a state with strong pnictogen bonding is unlikely to occur. This state of reduced c/a ratio has a different Fermi surface topology compared to LaFePO_3 ^[3] or SrFe_2P_2 ^[4].

We have experimentally measured the Fermi surface of CaFe_2P_2 using low-temperature torque magnetometry up to 45 tesla (T). We find the Fermi surface of CaFe_2P_2 to differ from other related ternary phosphides in that its topology is highly dispersive in the c axis, being three dimensional in character and composed of a large hole sheet in the form of a flat pillow at the top of the zone whereas the electron sheets are strongly distorted quasi-two dimensional cylinders centered on the zone corners. The mass enhancement is identical on both electron and hole pockets (~ 1.5) being mainly determined by electron-phonon interaction. Our results suggest that when the bonding between pnictogen layers becomes important nesting conditions are not fulfilled and may explain why the superconductivity is absent in such a state. These results have been published in *Physical Review Letters*⁵.

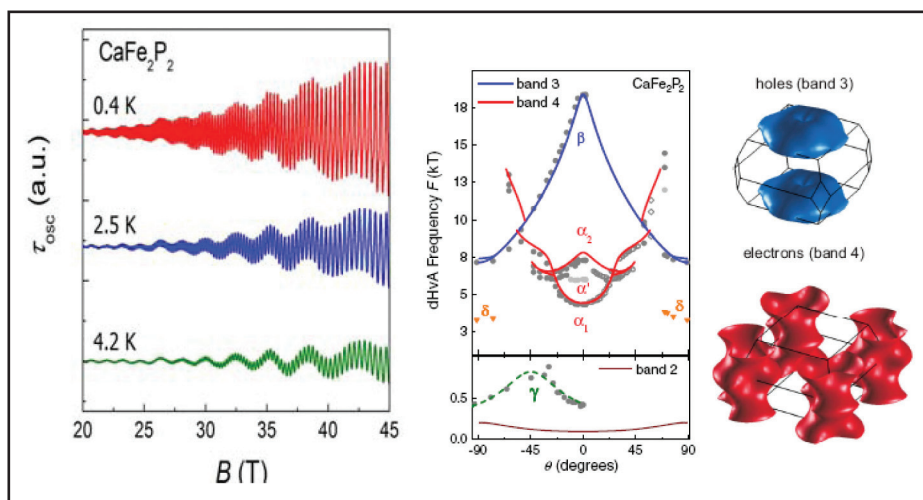

Figure 1. a) Quantum oscillations in CaFe_2P_2 obtained using torque magnetometry. b) The angular dependence of the fundamental frequencies (related to the extremal areas of the Fermi surface). The resulting Fermi surface of CaFe_2P_2 .

ACKNOWLEDGEMENTS

This work was supported financially by EPSRC (U.K.) and the Royal Society. Work at Stanford was supported by the U.S. DOE, Office of Basic Energy Sciences under contract DE-AC02-76SF00515. Work performed at the Magnet Lab in Tallahassee, Florida, was supported by NSF Cooperative Agreement No. DMR-0654118, by the state of Florida, and by the U.S. DOE.

REFERENCES

1. Torikachvili, M. S., *et al.*, *PRL*, **101**, 057006 (2008).
2. Yildirim, T., *PRL*, **102**, 037003 (2009).
3. Coldea, A.I., *et al.*, *PRL*, **101**, 216402 (2008).
4. Analytis, J. G., *et al.*, *PRL*, **103**, 076401 (2009).
5. Coldea, A.I., *et al.*, *PRL*, **103**, 026404 (2009).

Together with users from Italy, M. Putti *et al.* report high-field specific-heat measurements on the Sm and Ce members of the rare-earth (RE) family REFeAsO, the parent compounds of the now famous Fe-based oxypnictide high- T_c superconductors. In contrast to the other RE members (Ce, Pr, Nd), the low-temperature antiferromagnetic phase associated with the Sm compound is extremely robust against the application of large magnetic fields. This property is attributed to the uniaxial anisotropy of the Sm^{3+} ion, which is also unique to this family.

• This work was published in *Phys. Rev. B*, **80**, 214404 (2009).

Magnetic Ordering of the RE lattice in REFeAsO: The Odd Case of Sm. A Specific Heat Investigation in High Magnetic Field

M. Putti (University of Genova, Italy); S. Riggs, C. Tarantini, J. Jaroszynski, A. Gurevich (Magnet Lab); A. Palenzona, T. Duc Nguyen, M. Affronte (University of Modena and Reggio Emilia, Italy)

INTRODUCTION

A sharp peak in the specific heat data of SmFeAsO was found at 5.4 K related to the antiferromagnetic (AFM) ordering of Sm^{3+} . Preliminary measurements showed that this peak is rather independent of the applied magnetic field, differently from the cases of CeFeAsO and PrFeAsO that exhibit similar AFM transition related to the ordering of the rare earth. Due to the field resilience, the study of the AFM ordering of Sm^{3+} requires a high-field investigation.

RESULTS AND DISCUSSION

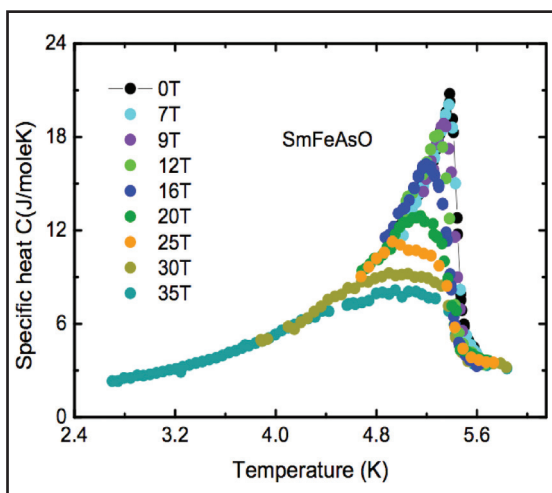

Figure 1.
Specific heat versus T of SmFeAsO up to 35 T.

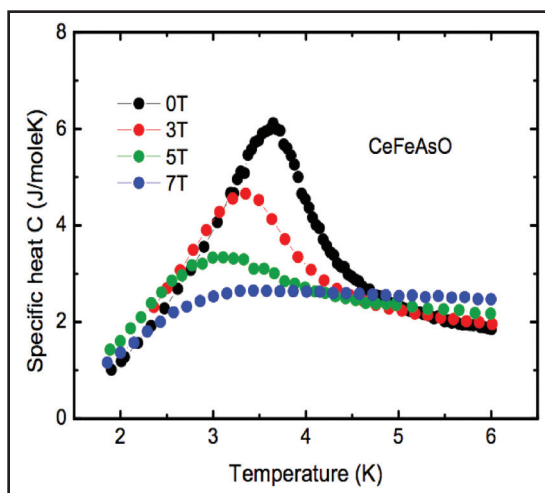

Figure 2.
Specific heat versus T of CeFeAsO up to 7 T.

Specific-heat measurements were performed in SmFeAsO in temperature range around the AFM transition up to 16 tesla (T) in a PPMS system and from 20 T to 35 T at the Magnet Lab and in CeFeAsO in

a PPMS system up to 7 T. Figure 1 shows a sharp peak of SmFeAsO at $T_N=5.4$ K corresponding with AFM transition. The anomaly remains very sharp up to 16 T and becomes rounded with little shift in temperature at higher fields. The initial slope of the ordering critical field dB_c/dT is 160T/K with $B_c(T)$ defined at the peak of the specific heat anomaly¹. The insensitivity to the application of an external magnetic field is unique to Sm and is not observed in CeFeAsO whose anomaly shifts with initial slope $dB_c/dT=5.7$ T/K (see Figure 2). We argue that SmFeAsO presents an unprecedented case of spin reorientation at the AFM transition. Recent neutron diffraction scattering measurements² show that Sm³⁺ has uni-axial order parallel to the c-axis, with FM ordering in the ab-planes, ordered AFM along the c-axis, which is also unique in the family of REFeAsO oxyphnictides where Ce³⁺, Pr³⁺ and Nd³⁺ order AFM with the spins along the ab-planes.

CONCLUSIONS

We have performed specific-heat measurements on SmFeAsO sample up to 35 T in order to investigate the magnetic transition involving the Sm sublattice. The specific-heat anomaly in SmFeAsO reveals a surprising insensitivity to the application of strong magnetic fields. Comparing our results to CeFeAsO we argue that the peculiarity of the SmFeAsO is related to the uniaxial magnetic anisotropy.

ACKNOWLEDGEMENTS

This work was supported by NSF Cooperative Agreement No. DMR-0654118, the state of Florida, the DOE and the Italian Foreign Affairs Ministry (MAE).

REFERENCES

1. Riggs, S., et al., *Phys. Rev. B*, **80** 214404 (2009).
2. Ryan, D.H., et al., *Phys. Rev. B* in print.

Users from Slovakia report magnetic susceptibility measurements on the antiferromagnetic compound, Cu(tn)Cl₂, at the high B/T facility in Gainesville. This material had been identified as a potential model system for studying effects of spin frustration on a two-dimensional (2D) triangular lattice, i.e. the spins cannot satisfy all near-neighbor interactions simultaneously in this geometry. However, a magnetic phase transformation is observed, which is reminiscent of the so-called Berezinskii-Kosterlitz-Thouless (BKT) transition expected for a truly 2D antiferromagnet.

• This work was published in *Phys. Rev. B*, **80**, 144418 (2009).

Interplay of Frustration and Magnetic Field for the 2D Quantum Antiferromagnetic Cu(tn)Cl₂

A. Orendáčová, E. Čížmár, L. Sedláková, J. Hanko, M. Kajňaková, M. Orendáč, V. Zeleňák, A. Feher (P. J. Šafárik University, Košice, Slovakia); J. S. Xia, L. Yin, D. M. Pajerowski, M. W. Meisel (UF Physics and Magnet Lab); S. Zvyagin, J. Wosnitza (Hochfeld-Magnetlabor Dresden, Germany)

INTRODUCTION

In 2006, the 2D quantum antiferromagnet Cu(tn)Cl₂ (tn = 1,3-diaminopropane = C₃H₁₀N₂) was identified as a potential model system for the realization of the spatially anisotropic triangular lattice from the collinear Néel phase¹. In zero field ($B = 0$), no evidence for long-range magnetic order was observed down to 60 mK, and the data suggested nearest-neighbor ($J/k_B = 3$ K), frustrating next-nearest-neighbor ($0 < J'/J < 0.6$), and interlayer ($|J''/J| = 10^{-3}$) interactions. The motivation of the present work² was to explore the response of Cu(tn)Cl₂ in $B > 0$, especially at $T \ll J/k_B$.

EXPERIMENTAL DETAILS

The magnetic susceptibility studies were performed in the Williamson Hall Annex (Room 123) of the High B/T Facility of the Magnet Lab in Gainesville, FL. The ac (232 Hz) mutual inductance coils were mounted on a dilution refrigerator equipped with a 10 tesla (T) magnet. The sample was bathed in pure ³He, which provided intimate thermal contact with the mixing chamber, and the in-phase and out-of-phase signals of the susceptibility were recorded by a two channel lock-in amplifier. The data were obtained by isothermal field sweeps at a rate of 50 mT/min and were independent of the direction of the field sweep.

RESULTS AND DISCUSSION

The results of isothermal ac susceptibility studies are shown in Figure 1, where the low field response

($B < 1$ T) is dominated by a background effect. The “shoulder” signature observed above 6 T is associated with the saturation magnetic field $B_{\text{sat}}(T \rightarrow 0) = 6.6$ T. These data resolved a crucial boundary of the magnetic phase diagram².

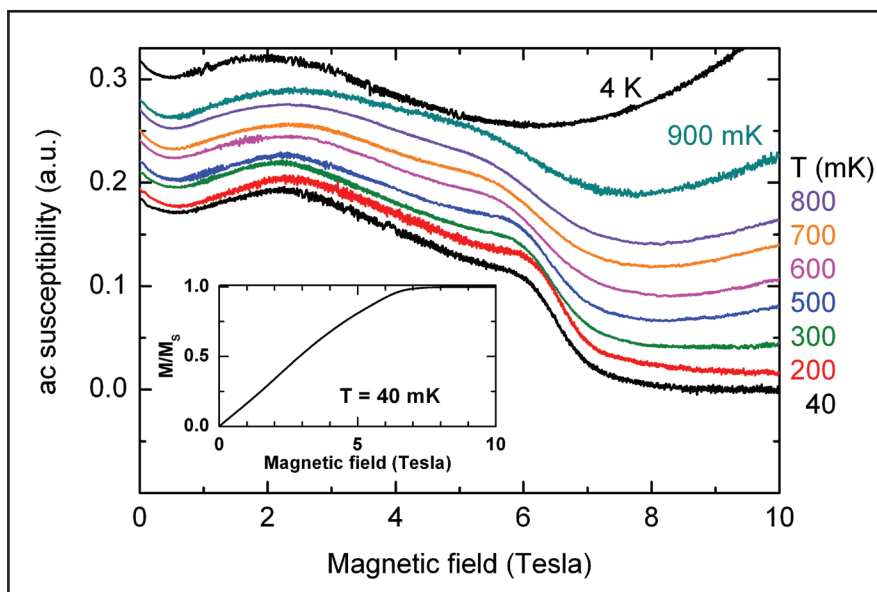

Figure 1. Magnetic field dependence of the isothermal ac susceptibility of Cu(tn)Cl. Inset: Magnetic field dependence of the normalized magnetization at 40 mK.

CONCLUSIONS

The analysis of all of the data allows the construction of the magnetic phase diagram², which is remarkably consistent with the one predicted for a BKT phase on a square lattice without a frustrating interaction³, except that B_{sat} is shifted to values lower than expected.

ACKNOWLEDGEMENTS

Elements of this research were performed in the Magnet Lab High B/T Facility. This work was supported, in part, by VEGA under Grant No. 1/0078/09, Project No. APVV-0006-07, ESF RNP program “Highly Frustrated Magnetism,” NSF under Grant No. DMR-0701400, the Magnet Lab via cooperative agreement NSF under Grant No. DMR-0654118 and the state of Florida, Deutsche Physikalische Gesellschaft (DPG), and EuroMagNET II. Material support from U.S. Steel Košice s.r.o. is greatly acknowledged.

REFERENCES

1. Zeleňák, V., *et al.*, *Inorg. Chem.*, **45**, 1774-1782 (2006).
2. Orendáčová, A., *et al.*, *Phys. Rev. B*, **80**, 144418 (2009).
3. Cuccoli, A., *et al.*, *Phys. Rev. B*, **68**, 060402(R) (2003).

Uranium goes through a series of lattice changes while cooling ($T \sim 43, 37$ and 23 K), resulting in a charge density wave (CDW) state at low temperatures. It had been previously assumed that to observe quantum oscillations the CDW state must be suppressed by applied pressure. Reported here are observations of de Haas van Alphen (dHvA) oscillations in α -uranium at ambient pressure, indicating a density of electronic states at the Fermi energy, in conflict with a simple CDW picture.

• This work was published in *Physical Review B*, **80**, 241101(R) (2009).

Magnetization Measurements of α -Uranium Using a Piezoresistive Cantilever in Pulsed Magnetic Fields

D. Graf, R. Stillwell, R. D. McDonald, C. M. Mielke, F. F. Bakariev, S. W. Tozer (Magnet Lab)

INTRODUCTION

The alpha phase of uranium (α -U) provides a unique setting to understand the role of f -electrons in the actinides. α -U undergoes three low-temperature charge density wave (CDW) transitions at temperatures of 43, 37, and 23 K, resulting in the volume of the unit cell below 23 K growing by a factor of 72 to 6000 \AA^3 .

Observing the Fermi surface of this element without first suppressing the complex structure created by the CDW transition was previously considered unlikely. High quality single crystals have been refined through annealing to produce unprecedented residual resistivity ratios as high as 570. Improved magnetic torque measurement techniques in pulsed fields¹ have allowed the observation of quantum oscillations in α -U².

EXPERIMENTAL

The magnetization of α -U was measured with a sample attached with silicon grease to the measurement arm of a piezoresistive cantilever. The cantilever was mounted on a rotation probe and centered in a 65 tesla (T) short-pulse magnet. Cantilever resistance changes created by torque from the sample were monitored by incorporating the cantilever into a Wheatstone bridge. The measurement temperatures are far below the lowest CDW transition at 23 K, so the lattice distortions leave the sample in the complex " α_3 " state.

RESULTS AND DISCUSSION

In figure 1, magnetization measurements from field pulses up to 65 T are shown. Only the data from the magnetic field downsweeps are shown and offset for clarity. Clear quantum oscillations are observed up to the maximum field and the fast Fourier transforms are shown in the figure inset. The measured orbit frequency ($F \sim 570$ T) agrees well with DC field measurements with the applied magnetic field aligned between the a and c -axes.

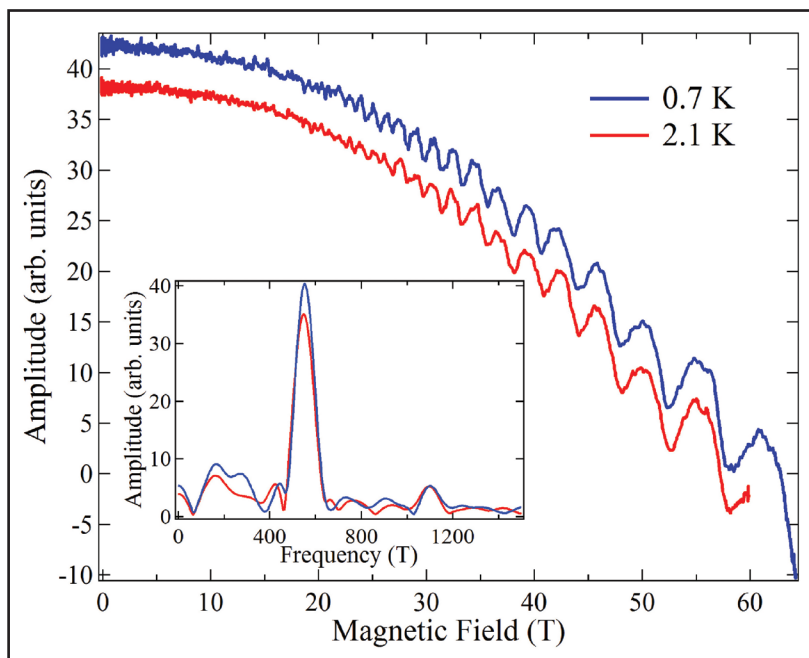

Figure 1. PRC measurements of the dHvA effect for α -uranium. Inset: Fast Fourier transform of the shown magnetization results.

CONCLUSIONS

Measuring the Fermi surface (FS) of α -U at ambient pressure is a significant step forward but leads to the question, how do the CDWs affect the FS topology? Schirber and Arko measured the FS of α -U under pressures above 8 kbar almost 30 years ago³, allowing for comparison between higher and ambient pressure results. So far, little agreement has been found between the orbits found under pressure (Ref. 3, $F \sim 1300 - 2400$ T) and in the present measurements (80 – 1500 T). In addition to pressure, high magnetic fields can be used to suppress CDW states but so far, we have not observed any signature in magnetization measurements that suggest a phase transition from the CDW state.

ACKNOWLEDGEMENTS

This work was supported by NSF Cooperative agreement DMR-0084713 (Magnet Lab) and DOE DE-FG52-06NA26193 (SWT group).

REFERENCES

1. Ohmichi, E., *et al.*, *Rev. Sci. Instr.*, **73**, 3022 (2002).
2. Graf, D., *et al.*, *Physical Review B*, **80**, 241101(R) (2009).
3. Schirber, J.E., *et al.*, *Physical Review B*, **21**, 2175 (1980).

For trigonal-axis magnetic fields in bismuth, the last Landau level is expected at $B=9$ tesla (T). However, recent experimental studies uncover a number of enigmatic effects beyond this quantum limit. For Nernst measurements in bismuth up to 45 T, we find evidence for unidentified electronic instabilities beyond the scope of a simple band-structure model. To understand these effects, theory must include electronic interactions, to date neglected, and to become significant above the quantum limit.

• This work was published in the *New Journal of Physics*, **11**, 113012 (2009).

An Electronic Instability in Bismuth Far Beyond the Quantum Limit

Benoît Fauqué and Kamran Behnia (ESPCI, Paris, France)

INTRODUCTION

When the field is applied along the trigonal axis of a bismuth crystal, no more crossing of the chemical potential by any known Landau level is expected for $B > 9$ T. However, recent experimental studies of various physical properties of bismuth uncover a number of enigmatic field scales beyond this quantum limit¹⁻³. We have extended the field range of the Nernst measurements in bismuth up to 45 T and uncovered a new field scale pointing to an unidentified electronic instability⁴.

EXPERIMENTAL

Nernst effect was measured by a miniature one-heater-two-thermometer set-up specially designed to work in the 45-T hybrid magnet. The Nernst data were complemented with resistivity measurements up to 55 T in a pulsed field performed in Toulouse.

RESULTS AND DISCUSSION

Figure 1 presents the transverse voltage generated by a constant thermal gradient at $T=1.2$ K as a function of magnetic field. The main new finding is the detection of a Nernst peak at $B = 37$ T, almost as drastic as the change caused by the crossing of the quantum limit at 9 T and much larger than previously detected¹ ultraquantum Nernst anomalies.

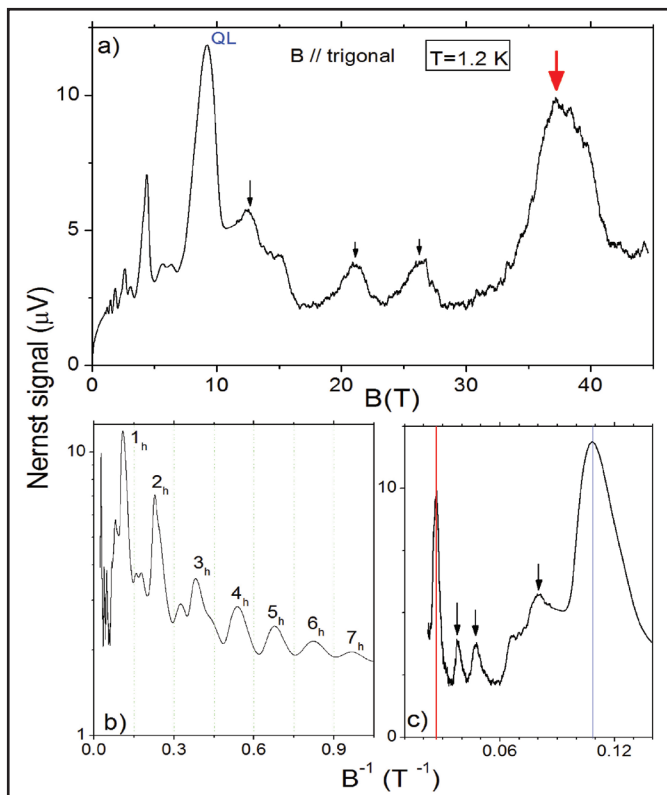

Figure 1.

a. Nernst signal as a function of the magnetic field. The new peak at 38 T (red arrow) is much larger than previously resolved peaks (black arrows); **b, c:** same data as a function of B^{-1} . Quantum oscillations are visible below the quantum limit (QL) marked by a blue vertical line. The field scales beyond this limit are caused by unidentified many-particle effects.

CONCLUSIONS

Our finding constitutes the most solid experimental evidence for a field-induced electronic instability beyond the scope of the band picture. The explanation of this field scale implies an appropriate treatment of the electronic interactions, which are neglected in this picture and are expected to become significant as the quantum limit is crossed.

REFERENCES

1. K. Behnia, L. Balicas and Y. Kopelevich, *Science*, **317**, 1729 (2007).
2. L. Li, *et al.*, *Science*, **321**, 547 (2008).
3. B. Fauqué, *et al.*, *Phys. Rev. B*, **79**, 245124 (2009).
4. B. Fauqué, *et al.*, *New J. Phys.*, **11**, 113012 (2009).

By combining pulsed electrically detected magnetic resonance (EDMR) and electron nuclear double resonance, researchers have realized a significant breakthrough in electrical readout of coherently controlled nuclear spins. For the first time, EDMR experiments were performed at high magnetic fields with devices patterned by electron beam lithography to have nanoscale contacts: just 50 nm × 50 nm

Electrical Readout of ^{31}P Spin Qubits in Crystalline Silicon at High Magnetic Fields

C. Boehme, D. R. McCamey (University of Utah, Physics); G. W. Morley, P. Studer, N. J. Curson (University College London and London Centre for Nanotechnology); G. A. C. Jones, D. Anderson (University of Cambridge, Physics); J. van Tol (Magnet Lab)

INTRODUCTION

Phosphorus (^{31}P) doped silicon (Si:P) is a technologically important material with possible uses in spintronic and quantum information processing devices. The goal of the work described in the following was to carry out pulsed EDMR experiments at high magnetic fields in order to (i) understand the sensitivity limitations of electrical spin measurements on ^{31}P and (ii) demonstrate electrically detected nuclear magnetic resonance by combination of pulsed EDMR and electron nuclear double resonance.

IMPROVING THE SENSITIVITY OF PULSED EDMR

EDMR was measured in Si:P devices with contacts patterned with electron beam lithography to have active areas of 50 nm × 50 nm. These measurements generally reproduced the features described in our previous research on devices with larger active areas¹⁻³, and used the same spectrometer^{4,5}.

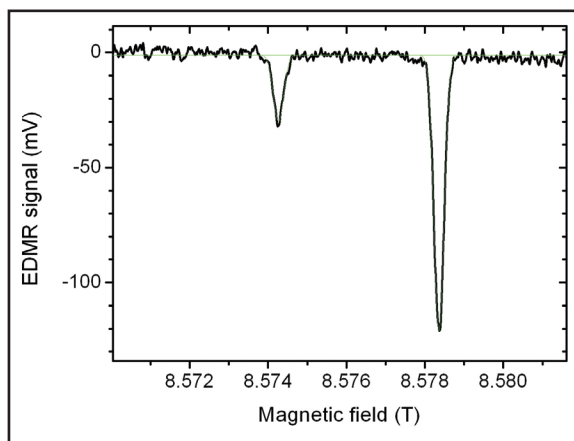

Figure 1. Continuous-wave EDMR at a temperature of 3 K with a bias current of 1.6 nA. Two Gaussians were used to fit the data.

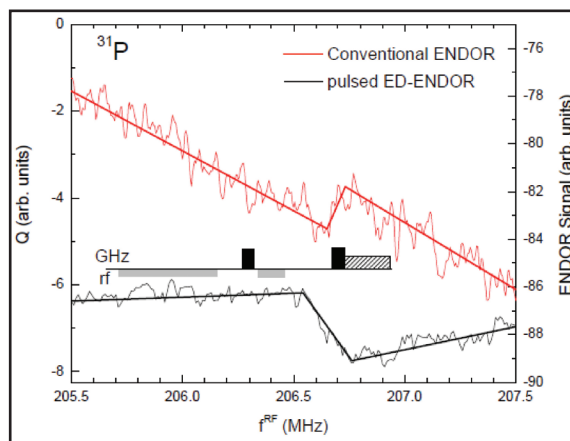

Figure 2. Conventionally detected (black) and electrically detected (red) pulsed ENDOR of ^{31}P donors in Si. The inset shows the pulse sequence used to measure the electrical signal. The top row is the GHz radiation resonant with the ^{31}P electron and the bottom the RF radiation whose frequency was swept through the ^{31}P nuclear resonance.

Figure 1 shows a spectrum recorded with a device having a thickness of 500 μm and a phosphorus concentration of $1\text{--}3 \times 10^{15} \text{ cm}^{-3}$. The two resonances are due to the two possible states of the phosphorus nuclear spin. The observation that one is larger than the other reproduces our previous finding that the application of white light polarizes these nuclear spins in a magnetic field of 8.5 T and a temperature of less than 3 K. High-field EDMR has not previously been demonstrated with contacts smaller than 10 micrometers so it is important to quantify the effect of scaling the contact sizes down. Previous scaling studies of low-field EDMR experiments with Si:P found that the signal-to-noise was approximately independent of the device size⁶. To scale down further we will use a silicon-on-insulator (SOI) wafer with a device thickness of 100–300 nm.

ELECTRICAL NUCLEAR SPIN DETECTION

We have also demonstrated pulsed, electrically detected electron nuclear double resonance (pEDENDOR) on Si:P. Figure 2 shows both a conventionally detected and electrically detected signal obtained from a pulsed ENDOR experiment. A resonance is seen at ~ 206.7 MHz in both cases. pEDENDOR of the ^{29}Si nuclear spins in the naturally abundant silicon host also were observed. Neither signal has the expected Gaussian lineshape. This is due to the extremely long nuclear spin lifetimes ($>$ minutes) of the ^{31}P donors, which lead to passage effects even at very slow sweep rates. Our proof-of-principle demonstration of electrical readout of coherently controlled nuclear spins at high fields provides a pathway towards the electrical readout of nuclear spin qubits. This technique also will be of wider use as a tool for investigating nuclear spins in macroscopic electrical devices, which are usually too small to be investigated with conventional resonance techniques.

ACKNOWLEDGEMENTS

We acknowledge support from the Magnet Lab Visiting Scientist Program.

REFERENCES

1. McCamey, D.R., *et al.*, *Phys. Rev. B*, **78**, 045303 (2008).
2. Morley, G.W., *et al.*, *Phys. Rev. Lett.*, **101**, 207602 (2008).
3. McCamey, D.R., *et al.*, *Phys. Rev. Lett.*, **102**, 027601 (2009).
4. van Tol, J., *et al.*, *Rev. Sci. Instrum.*, **76**, 074101 (2005).
5. Morley, G.W., *et al.*, *Rev. Sci. Instrum.*, **79**, 064703 (2008).
6. McCamey, D.R., *et al.*, *Appl. Phys. Lett.*, **89**, 182115 (2006).

The Read-Rezayi states – a sequence of two-dimensional (2D) topologically ordered states – may describe experimentally observed fractional quantum Hall effects and may also potentially be realized in rotating Bose gases. These are among the prime candidates for realizing non-Abelian anyons, which, in principle, can be used for topological quantum computation. The present work generalizes our earlier work by finding braiding patterns for topological quantum computation and by showing precisely how one would construct quantum gates to make realistic estimates of the resources required to carry out topological quantum computation using these exotic states of matter.

• This work was published in *Phys. Rev. Lett.*, **103**, 160501 (2009).

Topological Quantum Computing with Read-Rezayi States

L. Hormozi (NIST), S.H. Simon (Oxford), N.E. Bonesteel (FSU, Physics)

INTRODUCTION

The Read-Rezayi states are sequence of 2D topologically ordered states labeled by integer index k that may describe the experimentally observed $\nu = 5/2$ ($k=2$) and $\nu = 12/5$ ($k=3$) fractional quantum Hall effects. Read-Rezayi states may also potentially be realized in rotating Bose gases and are among the prime candidates for realizing non-Abelian anyons, which, in principle, can be used for topological quantum computation. In this work we have found a prescription for efficiently finding braids that can be used to carry out a universal set of quantum gates on encoded qubits based on anyons of the Read-Rezayi states with $k = 3, k > 4$. This work extends previous results^{1,2}, which only applied to the case $k = 3$ (the so-called Fibonacci anyons) and clarifies why, in that case, gate constructions are simpler than for a generic Read-Rezayi state.

RESULTS AND DISCUSSION

Although there are formal mathematical proofs that universal quantum computation is possible using the Read-Rezayi states with $k > 4$, our recent work³ is the first to show precisely how one would translate a given quantum algorithm into a braiding pattern using them. Figure 1 shows one of the braiding patterns we have found that indicates how a controlled-Phase gate between two qubits encoded using four anyons each would be carried out for the $k=5$ Read-Rezayi state³.

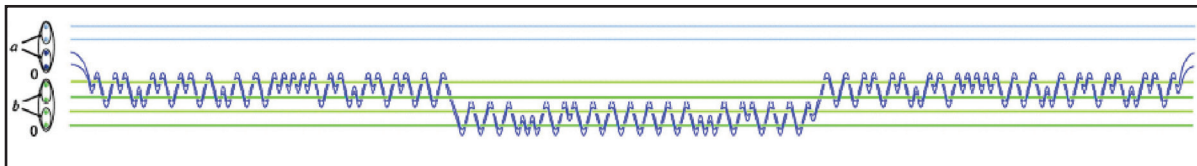

Figure 1.

Braiding pattern taken from [?] that can be used to realize a controlled-Phase gate for non-Abelian anyons described by $SU(2)_5$ Chern-Simons theory (the appropriate mathematical description of anyons in the $k=5$ Read-Rezayi state). Qubits are encoded using quadruplets of anyons and time flows from left to right. (For details of the notation used, see [?]).

CONCLUSIONS

The present work generalizes our earlier work on finding braiding patterns for topological quantum computation, which only applied to a single type of anyon ($k=3$), to an infinite class of anyons (all integer $k > 4$). By showing precisely how one would carry out quantum gates by braiding these anyons it becomes possible to make realistic estimates of the (demanding) resources that will be required to carry out topological quantum computation using these exotic states of matter.

ACKNOWLEDGEMENTS

Work supported by US DOE Grant No. DE-FG02-97ER45639.

REFERENCES

1. Bonesteel, N.E., *et al.*, *Phys. Rev. Lett.*, **95**, 140503 (2005).
2. Hormozi, L., *et al.*, *Phys. Rev. B*, **75**, 165310 (2007).
3. Hormozi, L.; Bonesteel, N.E.; Simon, S.H., *Phys. Rev. Lett.*, **103**, 160501 (2009).

Users at the High B/T facility performed nuclear magnetic resonance (NMR) studies to probe the local dynamics of very dilute ^3He impurities in solid ^4He , with the goal of testing for changes in the local motions near the temperatures for which non-classical rotational inertia fractions may point to macroscopic supersolid flow. Previous experiments confirmed that the ^3He impurities diffuse by quantum mechanical tunneling. This work is designed to test whether ^3He atoms become localized at dislocations or other defect sites in the “supersolid” region. The findings show that nanodroplets, rather than a solution of liquid ^3He , are formed at these low concentrations.

Nanodroplet Formation in Solid Solutions of Very Dilute ^3He in Solid ^4He

S. S. Kim (UF, Physics), C. Huan (UF, Physics), L. Yin (UF, Physics), J. S. Xia (UF, Physics), N. S. Sullivan (UF, Physics); D. Candela (Physics, Univ. of Mass.)

INTRODUCTION

NMR studies have been carried out to probe the local dynamics of very dilute ^3He impurities in solid ^4He . The goal of the experiment has been to test for changes in the local motions near the temperatures for which non-classical rotational inertia fractions have been observed¹. It is thought that these fractions point to macroscopic supersolid flow. Addition of ^3He impurities has been shown by others² to suppress the so-called “supersolid” effects and our previous experiments³ have confirmed that the ^3He impurities (at least for concentrations down to 250 ppm) diffuse by quantum mechanical tunneling⁴. The NMR experiments are designed to observe the motions down to approximately 10 ppm and to test whether ^3He atoms become localized at dislocations or other defect sites in the “supersolid” region.

EXPERIMENTAL

Two challenges had to be overcome to carry out the experiments. First, because of the weak thermal relaxation processes for the nuclear spins, we needed to carry out the experiments at low Larmor frequencies in order to keep the estimated relaxation rates below the order of 10^4 s. at low temperatures. Second, because of the low concentration and low magnetization due to the required low Larmor frequency, we developed a special low temperature preamplifier that could be placed adjacent to the NMR coil to significantly improve the NMR signal to noise⁵. Furthermore an ultra-quiet radio frequency (RF) environment was needed necessitating the use of the High B/T Facility, which is specially equipped for RF shielding.

RESULTS AND DISCUSSION

The amplitudes of the NMR signal (as measured by the amplitude of a solid echo) are shown in Figure 1. Above 120 mK a typical Curie law (T^{-1}) dependence is observed as expected for the paramagnetic behavior of the nuclear spins. Below 120 mK (at a temperature that varies with ^3He concentration) one observes a sharp change with a flat temperature independent behavior at low temperatures. This temperature independence is understood in terms of the formation of nanodroplets of liquid ^3He . Hysteresis is observed on cycling through the phase separation temperature.

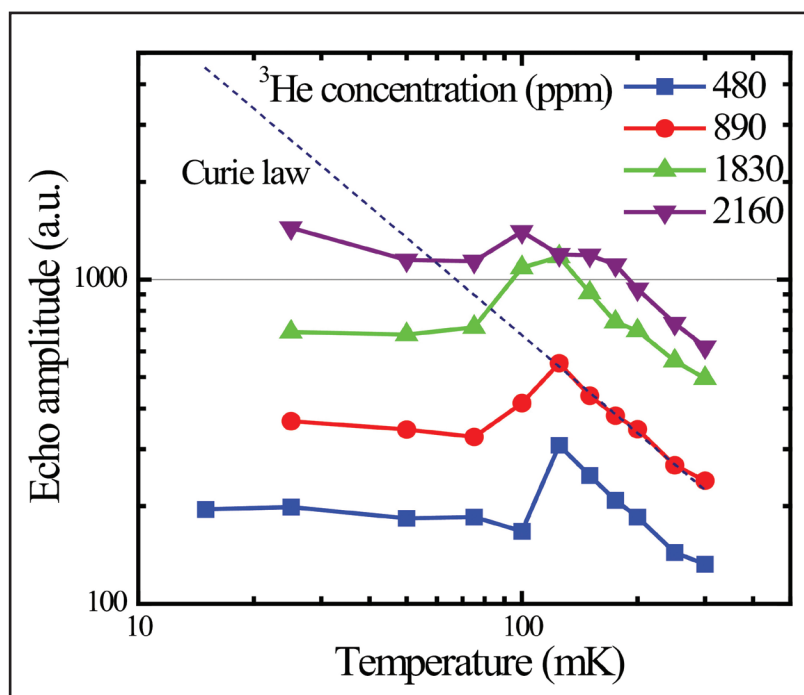

Figure 1.

^3He in solid ^4He . Temperature dependence of NMR echo amplitude showing phase separation and formation of ^3He nanoclusters below 150mK.

CONCLUSIONS

Careful NMR studies of ^3He impurities in solid ^4He have shown the formation of droplets of liquid ^3He in solid ^4He for very dilute solutions of ^3He in solid ^4He .

ACKNOWLEDGEMENTS

The research was supported by the Magnet Lab through the award from the User Collaboration Grants Program.

REFERENCES

1. Kim, E., *et al.*, *Nature*, **427**, 225 (2004).
2. Kim, E., *et al.*, *Phys. Rev. Lett.*, **100**, 065301 (2008).
3. Kim, S. S., *et al.*, *J. Low Temp. Phys.*, **158**, 584-589 (2010).
4. Richard, M. G., *et al.*, *J. Low Temp. Phys.*, **47**, 289 (1982).

Thermal expansion is a fundamental thermodynamic quantity. Its accurate measurement in confined spaces coupled with low temperatures and rapidly changing high magnetic fields suggests a new sensitive millimeter-scale dilatometer that has little or no temperature and field dependence. The authors designed an ultra compact dilatometer using an atomic force microscope (AFM) piezoresistive cantilever (PRC) as the sensing element and demonstrated its versatility by studying the charge density waves (CDWs) in alpha uranium to high magnetic fields up to 31 tesla (T).

• This work was published in *Rev. Sci. Instrum.*, **80**, 116101, 2009.

High Resolution Miniature Dilatometer Based on AFM Piezocantilever

J.-H. Park, D. Graf, T.P. Murphy, S.W. Tozer (Magnet Lab); G.M. Schmiedeshoff (Occidental College, Physics)

INTRODUCTION

Thermal expansion, or dilation of a material, is closely related to the specific heat, and provides useful information regarding material properties. The accurate measurement of dilation in confined spaces coupled with other limiting environments such as low temperatures and rapidly changing high magnetic fields requires a new sensitive millimeter scale dilatometer that has little or no temperature and field dependence. We have designed an ultra compact dilatometer using an AFM PRC as the sensing element and demonstrated its versatility by studying the charge density waves (CDWs) in alpha uranium to high magnetic fields up to 31 T¹.

DESIGN AND OPERATION

The principle of operation is to measure the change in resistance of an AFM PRC when the sample dimensions change. As schematically shown in Figure 1 (left panel), for a z-direction dilation measurement, the sample and PRC are glued to a substrate. The tip of the PRC gently rests on the sample with the AFM tip facing up such that a 1% change in nominal resistance is generated thereby assuring that the tip and sample will not separate as the sample contracts upon cooling. The resistances of the piezo element and the reference piezo element then can be monitored using a Wheatstone bridge configuration. Using this PRC, charge density wave transitions of depleted alpha uranium (thickness 0.04 mm) were measured in the 31-T resistive magnet (cell 9, DC facility, Magnet Lab) and the result (Figure 1, right panel) shows three distinct CDW transitions (denoted as α_1 , α_2 , and α_3) and proves the capability of this new dilatometer.

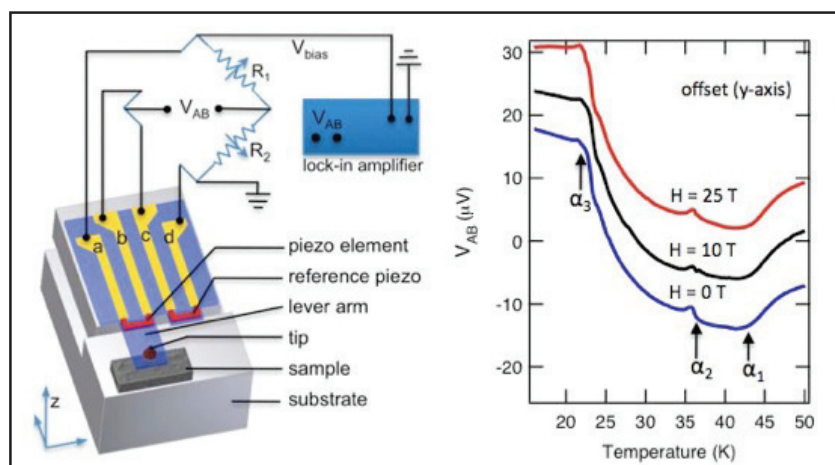

Figure 1. Schematic diagram of piezoresistive cantilever dilatometer (left) and charge density wave transitions in alpha-uranium probed by piezoresistive dilatometer (right).

ACKNOWLEDGEMENTS

Support for this work was provided by the DOE/NNSA under DE-FG52-06NA26193. Work was performed at the Magnet Lab, which is supported by NSF Cooperative Agreement No. DMR-0654118 and by the state of Florida. Work at Occidental College was supported by the NSF under DMR-0704406.

REFERENCES

1. Park, J.-H., *et al.*, *Rev. Sci. Instrum.*, **80**, 116101 (2009).

The ability to measure specific heat at very high magnetic fields represents a long-standing objective of Mag Lab user programs. Until now, such measurements have not been possible in the shorter pulsed high-field magnets. The report by Y. Kohama *et al.* describes a new AC specific heat measurement technique and its successful implementation to detect a field induced phase transition above 30 tesla (T) in the spin-dimer compound $\text{Sr}_3\text{Cr}_2\text{O}_8$.

First AC Heat Capacity Measurement in Capacitor-Bank-Driven Pulsed Fields

Yoshimitsu Kohama (Magnet Lab-LANL), Christophe Marcenat (CEA-Grenoble, Institut Nanosciences et Cryogenie, SPSMS-LATEQS), Marcelo Jaime (Magnet Lab-LANL)

INTRODUCTION

Specific heat (C_p) at high fields is one of the fundamental techniques for understanding the mechanisms and physics at play in correlated electron and magnetic materials. So far, a number of specific heat measurements in very high DC and long pulsed magnetic fields have been reported. Here, applying an AC- C_p technique running in the kHz range, we report the development of a new calorimeter for measurement in mid (250 msec) pulsed magnetic fields.¹

EXPERIMENTAL

We used RuO_2 bare chips (State of the Art Inc.) as thermometers for mid-pulsed magnetic fields, which show a monotonic 6-7% magnetoresistance. The RuO_2 thermometer was glued to a Si plate with GE7031 varnish. The sample was mounted on the RuO_2 thermometer and glued with silver paint. A NiCr film heater with a thickness of 10 nm, ~ 10 kohm, was directly deposited on the sample. By applying AC current at a frequency of ~ 1 kHz to the heater, we could detect the second harmonic oscillation with an in-house digital lock-in system. As a test sample, we choose $\text{Sr}_3\text{Cr}_2\text{O}_8$ and Si single crystals. While Si shows no phase transition in magnetic fields up to 50 T, $\text{Sr}_3\text{Cr}_2\text{O}_8$ shows a magnetic ordered state between $H_{c1} \approx 30.4$ and $H_{c2} \approx 62$ T.²

RESULTS AND DISCUSSION

Figure 1 shows the resulting AC- C_p data in $\text{Sr}_3\text{Cr}_2\text{O}_8$ and Si single crystal samples. $\text{Sr}_3\text{Cr}_2\text{O}_8$ shows a sharp peak at $H \approx H_{c1}$, while the Si single crystal does not show any anomaly. In the figure inset, the peak also shows temperature dependence, which is consistent with the previous magnetocaloric effect (MCE) studies.¹ Although it is difficult to compare the shape of peak with the data taken in DC fields (red curve) due to the temperature difference, the DC field data also show peak as a function field. A similar temperature-suppression of the anomaly in $C_p(H)$ was recently observed in $\text{NiCl}_2\cdot 4\text{SC}(\text{NH}_2)_2$.³

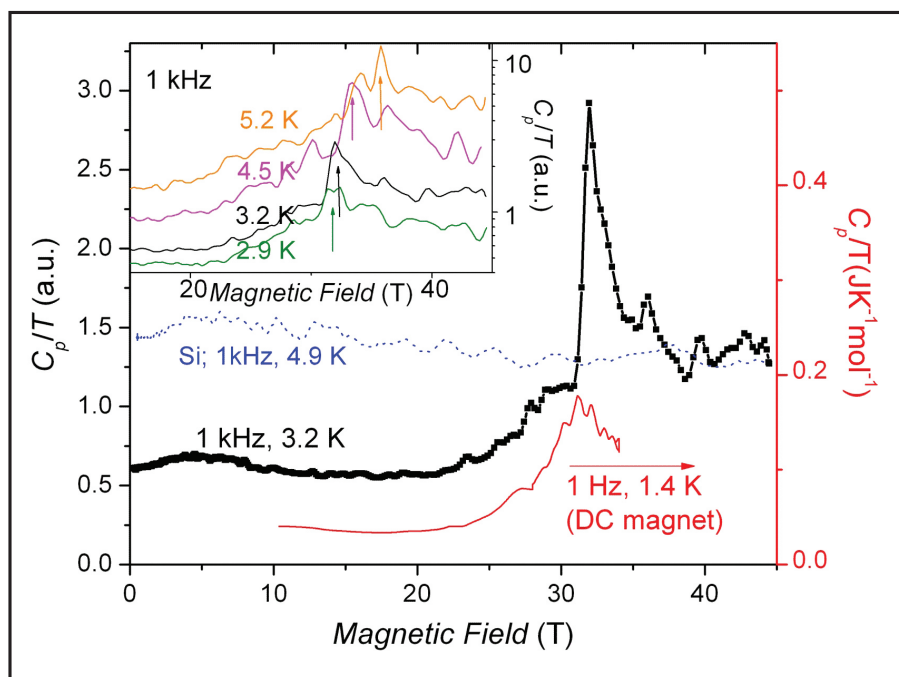

Figure 1. $C_p(H)$ measured in $\text{Sr}_3\text{Cr}_2\text{O}_8$ with a new AC calorimeter for mid-pulsed magnets.

CONCLUSIONS

A new calorimeter was built for AC- C_p measurement in a 50 T capacitor-bank-driven mid-pulsed magnet. Initial results are consistent with previous DC measurements. Additional tests are underway.

ACKNOWLEDGEMENTS

We are indebted to A. A. Aczel and G. Luke for providing the $\text{Sr}_3\text{Cr}_2\text{O}_8$ single crystals used for these experiments. This work was supported by the National Science Foundation, the U.S. Department of Energy and the state of Florida.

REFERENCES

1. Kohama, Y., *et al.*, *Rev. Sci. Inst.*, to be published (arXiv:1003.3184).
2. Aczel, A.A., *et al.*, *Phys. Rev. Lett.*, **103**, 207203 (2009).
3. Zapf, V.S., *et al.*, (unpublished).

K. Koyama *et al.* report high temperature ($> 350^\circ\text{C}$) differential thermal analysis (DTA) measurements on the technologically important ferromagnetic binary alloy MnBi in the 45 tesla (T) hybrid magnet. A remarkable field dependence of the temperature (T_t) at which the alloy decomposes into a mixture of paramagnetic and liquid phases is reported; $\Delta T_t = 80^\circ\text{C}$ at 45 T. The observed behavior is mainly attributed to the field-induced magnetic moment of the ferromagnetic phase.

Decomposition Temperature of MnBi to 45 Tesla

K. Koyama (Tohoku U, Institute for Materials Research); Y. Mitsui (Tohoku U, IMR); E.S. Choi (FSU, Magnet Lab); Y. Ikehara (Tohoku U, IMR); K. Watanabe (Tohoku U, IMR); E. Palm (FSU, Magnet Lab)

INTRODUCTION

Scientists all over the world use steady, high-field magnets to study the effects of high magnetic fields on magnetic phase transitions, chemical reactions, physical processes, and solidifications. In order to study these phenomena, thermal analysis under high magnetic fields is one of the most important experiments. Recently, Koyama *et al.* observed that the decomposition temperature T_t ($=355^\circ\text{C}$, 628 K at a zero magnetic field) of MnBi increases linearly with increasing magnetic fields up to 14 T at the rate of $\sim 2^\circ\text{C}/\text{T}$. This result indicates that the equilibrium diagram of the Mn-Bi binary system is affected and controlled by a high magnetic field. The purpose of this study is to perform a high-field DTA experiment for ferromagnetic MnBi in high magnetic fields and high temperatures by combining DTA and the 45-T hybrid magnet (the world's highest steady magnet field) to get the first data on magnetic field effects on decomposition process and a corresponding phase diagram.

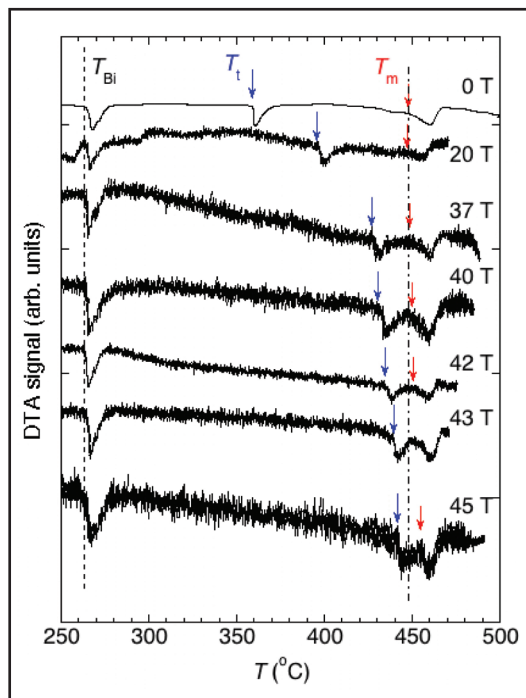

Figure 1.

Typical results of DTA curves of MnBi under various magnetic fields up to 45 T.

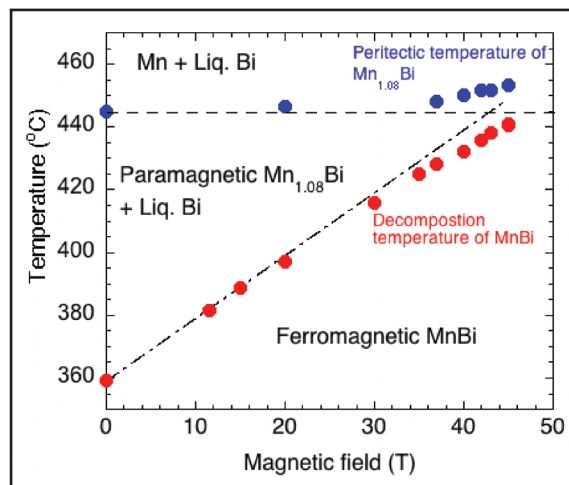

Figure 2.

Phase diagram of MnBi. The red solid circles indicate T_t determined by DTA. The dashed lines are eye guides.

EXPERIMENTAL

A DTA signal was measured for powder MnBi (~100mg) in magnetic fields up to 45 T using the 45T-hybrid magnet in the temperature range of 20-500°C (293-773 K). The measurement was performed in the heating process at the rate of ~5°C/min.

RESULTS AND DISCUSSION

Figures 1 and 2 show the typical results of DTA curves of MnBi under various magnetic fields up to 45 T and the phase diagram, respectively. The melting point of Bi (T_{Bi}) is not changed by magnetic field. On the other hand, the decomposition temperature T_t ($MnBi \rightarrow Mn_{1.08}Bi + Liq. Bi$) increases linearly with increasing B up to ~20 T, but the data over 20 T deviate from the straight line (~2°C/T). In addition, we found that the peritectic temperature T_m increases with increasing B , which is clearly observed over 40 T. These phenomena (the deviation of T_t from the straight line and the increase of T_m) are probably due to the field-induced magnetic moment of $Mn_{1.08}Bi$. We are now calculating the equilibrium diagram of the Mn-Bi binary system in a high magnetic field to check the obtained experimental results.

CONCLUSIONS

The HF-DTA experiment was performed in high magnetic fields up to 45 T for the first time. The obtained results clearly show that the decomposition temperature and peritectic temperature of Mn-Bi increase with increasing magnetic field.

ACKNOWLEDGEMENTS

This work was partly supported by the Iketani Science and Technology Foundation.

REFERENCES

1. K. Koyama, *et al.*, *Mater. Trans.*, **48**, 2414-2418 (2007).

This work reports both the first truly epitaxial pnictide films and bicrystals that enable the properties of grain boundaries to be measured. Sadly a similar depression of superconducting properties to that found in the cuprates is seen, suggesting that this property is intrinsic to superconductors formed by doping carriers into a parent non-superconducting state.

• This work was published in *Appl. Phys. Lett.*, **95**, 21/212505 (2009).

Current Transport at Grain Boundaries in Superconducting $\text{Ba}(\text{Fe}_{1-x}\text{Co}_x)_2\text{As}_2$ Bicrystals

J. Jiang, J. D. Weiss, C. Tarantini, A. Xu, D. Abraimov, A. Polyanskii, A. Yamamoto, F. Kametani, E. E. Hellstrom, A. Gurevich, D. C. Larbalestier (Mag Lab-FSU); S. Lee, C. M. Folkman, C. W. Bark, S. H. Baek, H. W. Jang, C. B. Eom (U. of Wisconsin); C. T. Nelson, Y. Zhang, X. Q. Pan (U. of Michigan)

INTRODUCTION

Grain boundaries (GBs) transparent to current are intrinsic to Nb-Ti, Nb_3Sn and MgB_2 . The ferropnictide superconductors have important application properties, namely T_c up to 55 K, H_{c2} of 100 tesla (T) or more, strong vortex pinning, moderate anisotropy, and H_{irr} close to H_{c2} , leaving open only the key question whether GBs can transmit current. Here we report the explicit study of this vital property, using extensive transport, magneto-optical (MO), low-temperature laser scanning microscopy (LTLSM), and high resolution transmission electron microscopy (HRTEM) investigations of $\text{Ba}(\text{Fe}_{1-x}\text{Co}_x)_2\text{As}_2$ (Ba-122) epitaxial thin film bicrystals.

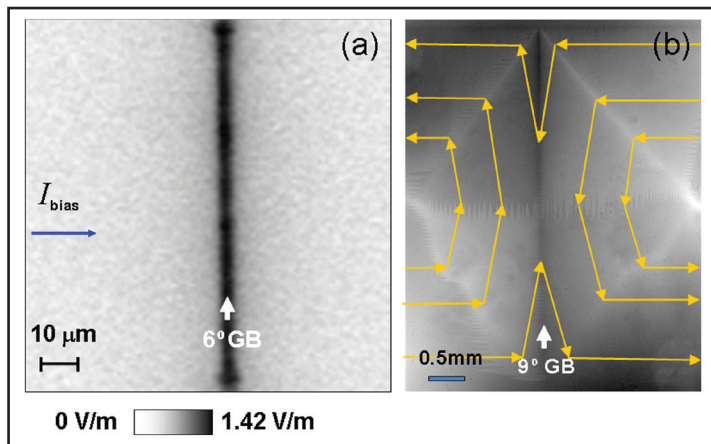

Figure 1.

Depressed superconductivity at the grain boundary (GB) adds dissipation. (a) LTLSM image of the local electric field developed at 6° GB. (b) Magneto-optical image and the current stream lines turning due to the blocking effect of 9° GB

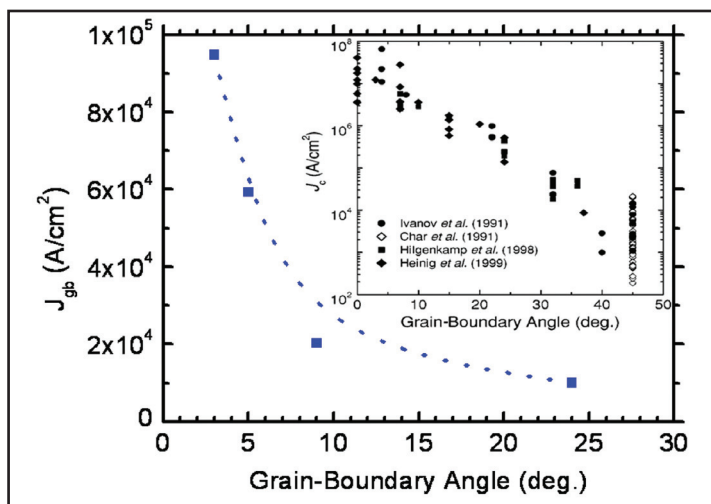

Figure 2.

Dependence of the critical current density J_c (12 K, 0.5 T, H perpendicular to the film) as a function of the GB misorientation angle θ . The insert shows summary data for YBCO GBs. The rapid drop in $J_{gb}(\theta)$ with increasing θ in the Ba-122 bicrystals exhibits a similar qualitative dependence on the misorientation angle θ .

EXPERIMENTAL

Epitaxial ~350 nm thick Ba-122 thin films were grown *in-situ* on [001] tilt (100) SrTiO₃ bicrystal substrates. Four-circle X-ray diffraction showed excellent epitaxy with cube-on-cube, in-plane epitaxial relationship with the substrates. We performed detailed studies of the grain and GB critical current densities $J_c(T,B)$ and $J_{gb}(T,B)$ for the bicrystals.

RESULTS

Shown in Figure 1 are representative LTLSM and MO images of 6° and 9° bicrystals, which demonstrate the significant current-blocking effect of even low-angle GBs. The MO image in Figure 1b shows that the 9° [001] tilt GB can transmit only about 10% of the intragrain critical current. Figure 2 shows that $J_{gb}(12K, 0.5T)$ falls off by an order of magnitude as θ increases from 3 to 24°. This qualitative behavior is similar to $J_{gb}(\theta)$ for [001] tilt GBs in YBCO. The 3° GB in Ba(Fe_{1-x}Co_x)₂As₂ does not obstruct supercurrent, while at higher angles $J_{gb}(\theta)$ becomes much smaller than the grain J_c .

CONCLUSION

We have developed a process for growing pnictide Ba-122 single crystal thin films. J_{gb} across [001] tilt GBs of thin film Ba(Fe_{1-x}Co_x)₂As₂ bicrystals is strongly depressed, similar to high- T_c cuprates. Our results raise the question as to whether weak-linked GBs are characteristic of high- T_c superconducting compounds developed from parent non-superconducting states with competing orders, low carrier density, and unconventional pairing symmetry.

ACKNOWLEDGEMENTS

Work at the Magnet Lab was supported under NSF Cooperative Agreement DMR-0084173, by the state of Florida, and by AFOSR grant FA9550-06-1-0474. Work at UW was supported by DOE grant DE-FG02-06ER463. Work at the University of Michigan was supported by the Department of Energy under grant DE-FG02-07ER46416.

REFERENCES

1. S. Lee, *et al.*, *Appl. Phys. Lett.*, **95**, 212505 (2009).

It is now clear that YBCO can be used not just for magnets of great strength at 4 K, but also to make magnets that generate more usual fields of 5 to 15 tesla (T) in the temperature range up to 65 K or more. The limits to operation are set by the irreversibility field at which the critical current density goes to zero. In this recent *Applied Physics Letter*, it is shown that the very strong pinning centers that now can be put into YBCO coated conductors enhance the irreversibility field over a broad angular range, the effects being largest at higher temperatures where they are of greatest practical use.

- This work was published in *Appl. Phys. Lett.*, **96**, 072506 (2010).

Vortex Liquid-glass Transition Up to 60 T in Nano-engineered Coated Conductors

M. Miura (Japan Society for the Promotion of Science; Superconductivity Research Laboratory-International Superconductivity Technology Center, Japan; MPA-STC, LANL); S.A. Baily, B. Maiorov, L. Civale, J.O. Willis, K. Marken (MPA-STC, LANL); T. Izumi, K. Tanabe, Y. Shiohara (SRL-ISTEC)

INTRODUCTION

Higher irreversibility fields (H_{irr}) increase the upper bound for applications of high T_c superconductors and could expand their market penetration¹. We performed the first pulsed-field studies of the resistive transition in superconducting films on flexible metal substrates, known as coated conductors (CC). We investigated the effect of disorder on H_{irr} and the upper critical field (H_{c2}) at different orientations of the magnetic field (\mathbf{H}) for YBa₂Cu₃O_y (YBCO) and BaZrO₃-nanoparticle dispersed Y_{0.77}Gd_{0.23}Ba₂Cu₃O_y (YGdBCO+BZO).

EXPERIMENTAL

The two samples used in this study are bridges of 0.5 μm -thick CC of YBCO and YGdBCO+BZO grown by a trifluoroacetate metal organic deposition process on IBAD metal templates². A low AC current density

$J \sim 400 \text{ A/cm}^2$ was applied along the bridge. In the DC field studies (up to 15 T) a rotating stage was used to rotate the CC with respect to \mathbf{H} . Sixty-five T pulsed-field measurements were performed while maintaining the sample at fixed angles. In all cases $\mathbf{J} \perp \mathbf{H}$ (maximum Lorentz force). The H_{c2} and H_{irr} were determined using $0.9\rho_n$ and $0.01\rho_n$ criteria respectively, where ρ_n is the normal state resistivity.

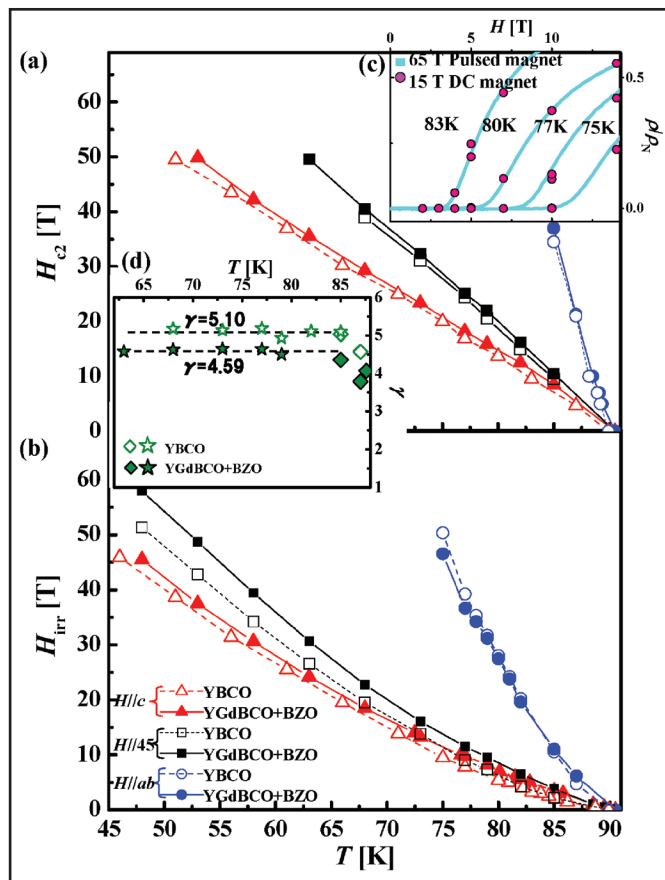

Figure 1

Temperature dependence of (a) H_{c2} and (b) H_{irr} with $\mathbf{H}||c$, $\mathbf{H}||ab$, and $\mathbf{H}||45^\circ$ for YBCO and YGdBCO+BZO CCs. (c) Normalized resistivity vs. magnetic field at $\mathbf{H}||c$ for YBCO CC using both pulsed (lines) and DC fields (circles). (d) Temperature dependence of γ , for YBCO (open symbols) and YGdBCO+BZO (solid symbols) CCs, calculated using H_{c2}^{ab} , H_{c2}^c (diamonds) & H_{c2}^{45} , H_{c2}^c (stars).

RESULTS AND DISCUSSION

Since these films are grown on metal substrates, eddy current heating in pulsed fields was a concern. By comparing results obtained using pulses of various magnitudes and DC fields, heating was found to be negligible (Figure 1c). The electronic mass anisotropy (γ) of both samples was calculated from the H_{c2} values at 3 angles (Figure 1d)³, and is consistent with the expected values for compounds of the YBCO family.

Introducing BZO nanoparticles has little effect on H_{c2} (Figure 1a), but enhances H_{irr} especially at 45° (Figure 1b), probably due to a combination of two-dimensional and three-dimensional disorder resulting in characteristic glassy phases at $\mathbf{H}||c$ and $\mathbf{H}||45^\circ$ up to 60 T. For $\mathbf{H}||45^\circ$ the smaller critical exponent s in $\rho=(H-H_m)^s$ obtained for YGdBCO+BZO is indicative of a Bose-glass-like pinning landscape. Understanding mixed pinning landscapes is critical to improving H_{irr} ⁴. We find that CCs have similar or better high field properties than films grown on single crystals^{3,5}. This result indicates that nano-engineered coated conductors are an enabling technology for high field applications.

ACKNOWLEDGEMENTS

This work is supported by the Magnet Lab User Collaboration Grants Program, NSF, U.S. DOE Office of Electricity Delivery and Energy Reliability, U.S. DOE Office of Basic Energy Sciences, Division of Materials Sciences and Engineering, and the state of Florida.

REFERENCES

1. Larbalestier, D.C., *et al.*, *Nature*, **414**, 368–377 (2001).
2. Miura, M., *et al.*, *Appl. Phys. Express*, **2**, 023002 (2009).
3. Miura, M., *et al.*, *Appl. Phys. Lett.*, **96**, 072506 (2010).
4. Mayorov, B., *et al.*, *Nature Materials*, **8**, 398 (2009).
5. Baily, S. A., *et al.*, *Phys. Rev. Lett.*, **100**, 027004 (2008).

The principal barrier to applications of the cuprates has been the tendency of grain boundaries (GBs) to lose superconductivity. This work shows that adding carriers to the GBs really does improve the GB properties in the most preferred geometry of a round wire, multifilament conductor.

• This work was published in *Appl. Phys. Lett.*, **95**, 152516 (2009).

Development of High Critical Current Density in Multifilamentary Round-wire $\text{Bi}_2\text{Sr}_2\text{CaCu}_2\text{O}_{8+\delta}$ by Strong Overdoping

T. Shen, J. Jiang, U.P. Trociewitz, E. E. Hellstrom and D.C. Larbalestier (Magnet Lab-ASC, FSU)

INTRODUCTION

A major obstacle to the applications of cuprate high-temperature superconductors is the tendency of cuprate grain boundaries (GBs) with misorientation angle $\theta > 3-4^\circ$ to have depressed critical current density, J_c , due to local GB suppression of the carrier density and the superconducting order parameter. Surprisingly, $\text{Bi}_2\text{Sr}_2\text{CaCu}_2\text{O}_x$ can be made into a high J_c round-wire conductor with little macroscopic texture, in contrast to other cuprates (e.g. $(\text{Bi,Pb})_2\text{Sr}_2\text{Ca}_2\text{Cu}_3\text{O}_{x'}$, $\text{YBa}_2\text{Cu}_3\text{O}_{7-\delta}$), which all require sophisticated crystallographic texture fabrication processes to eliminate all but low angle grain boundaries to develop high J_c in tape/thin film form. Since the cuprate GB problem is widely believed to be intrinsic to its small carrier density and proximity to a parent, antiferromagnetic insulating state, understanding the remarkable properties of round-wire, Ag-sheathed Bi-2212 conductor has quite general importance. This report addresses the important final step that greatly enhances the cuprate's J_c and ties it to oxygenation treatments that overdope the Bi-2212 phase in ways that are generally not possible in Bi-2223 or YBCO.

EXPERIMENTAL

We quenched 4 cm long sections of an Ag-sheathed Bi-2212 multifilament round wire fabricated by Oxford Superconducting Technology at multiple points in the process using brine as the quench medium (Figure 1 inset). Microstructures were carefully examined and phase chemistry was determined using a field emission scanning electron microscope. The important point is that no observable change in the phase state occurred below the highest temperature examined here, 836 °C. T_c was evaluated from zero-field-cooled magnetic moments measured in a SQUID magnetometer on 5 mm long samples with the wire axis parallel to **H**. The irreversibility field H_{irr} was approximated by linear extrapolation of the Kramer function $\Delta M^{0.5} H^{0.25}$ to zero, defining H_K . The inter- and intra-grain contributions to the hysteretic moment ΔM were deduced from the remnant moment $m_R(H_a)$, determined in the SQUID magnetometer^[1].

RESULTS AND DISCUSSION

Our central result is that low temperature oxygenation of a macroscopically untextured, round wire multifilamentary Bi-2212 conductor produces a more than twofold enhancement of in-field J_c . These treatments enable the high J_c values for high-field magnets. The oxygen pick up overdopes Bi-2212 phases, decreasing T_c from 92 to 80 K (Figure. 2), but in all other aspects enhancing the superconducting properties (increased pinning shown in Figure 3 and enhanced connectivity in Figure 4).

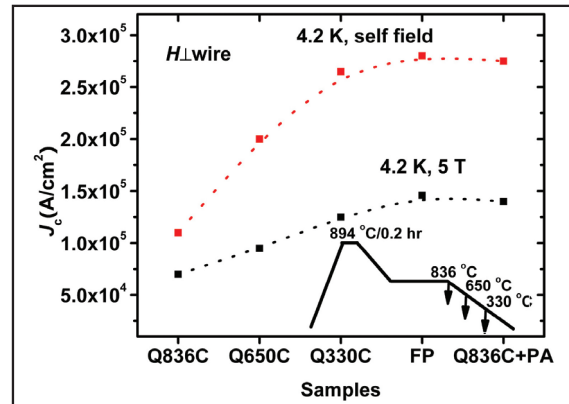

Figure 1.

Significant increases in 4.2 K transport J_c of Bi-2212 round wire in the final state of the partial-melt process (inset).

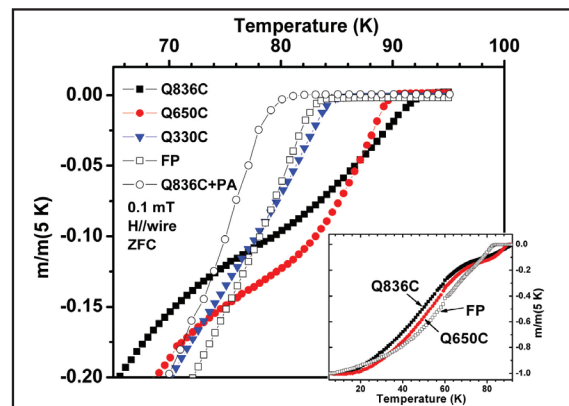

Figure 2.

Zero-field-cooled magnetic moments of Ag-sheathed Bi-2212 multifilament round wire indicates that significant oxygen overdoping occurs during the final cooling to room temperature.

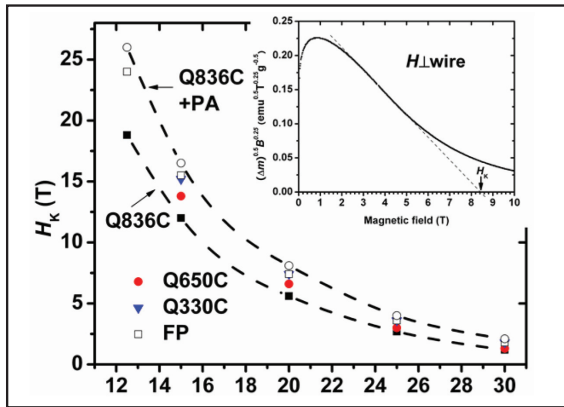

Figure 3. Kramer irreversibility field as a function of temperature for Q836C, Q650C, Q330C, FP, and Q836C+PA. (Q836C means quenching from 836 °C). Inset shows our method of determining H_K .

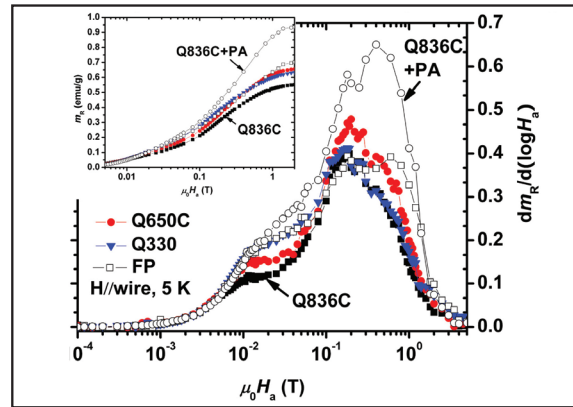

Figure 4. Dependence of the remanent magnetic moment m_R (inset) and its derivative for the Bi-2212 round wires as measured for increasingly fields applied parallel to the wire axis at 5 K.

ACKNOWLEDGEMENTS

This work is supported by U.S. National Science Foundation Division of Material Research through DMR-0654118 and the DOE through Very High Field Superconducting Magnet Collaboration.

REFERENCE

1. T. Shen, *et al.*, *Appl. Phys. Lett.*, **95**, 152516 (2009)

Grain boundaries can be engineered by high magnetic field, and the engineered boundaries can provide unique material properties. The users from Aachen University measured the absolute mobilities of different asymmetric $\langle 1010 \rangle$ tilt grain boundaries of high-purity zinc in high-field magnets. The data will lead to a deeper understanding of the mechanisms of grain-boundary migration and offer us new tools to engineer the grain boundaries by high field magnets.

In-situ Measurements of Magnetically Driven Motion of Specific Individual Grain Boundaries in Zn with a High Field Magnet Microscopy Probe

Ch. Günster, D.A. Molodov (RWTH Aachen University, Inst. of Physical Metallurgy and Metal Physics)

INTRODUCTION

Experiments with a space-resolving high magnetic field polarization microscopy probe were conducted¹. This high-field probe represents a unique means to collect data about grain boundary kinetics and energy by continuously tracking the position and the shape of a grain boundary in magnetically anisotropic, crystalline materials.

EXPERIMENTAL

Samples of 99.995% pure zinc bicrystals containing $\langle 1010 \rangle$ grain boundaries were annealed with sample axis perpendicular to the magnetic field. Bicrystals containing either tilt or twist boundaries with misorientation angles in the range between 55° and 88° were examined. One of the two grains in the samples had its c-axis aligned parallel to the field, while the c-axis in the other grain was inclined to field direction. Due to the different alignment of c-axes in adjacent grains with respect to the magnetic field, a driving force for grain boundary motion is induced, which is caused by different magnetic susceptibilities parallel and perpendicular to the c-axis in Zn. The grains with c-axis perpendicular to the field are energetically favored, which allows them to grow at the expense of grains with energetically disfavored orientations.

RESULTS

During experiments at the Magnet Lab, the kinetics of individual $\langle 1010 \rangle$ tilt boundaries in high purity zinc were addressed. The absolute mobilities of different asymmetric tilt grain boundaries were measured in the range between 340 and 410° C and their activation parameters determined (Figure 2). Comparing our

data to that obtained by Sursaeva *et al.*³, who investigated symmetrical, curvature driven boundaries in Zn, our results show higher activation parameter values for asymmetric boundaries. This discrepancy between activation parameters for symmetric and asymmetric boundaries corresponds to results from experiments by Molodov *et al.* with Bi in 1998², in which the kinetics of both symmetric and asymmetric $90^\circ\langle 112\rangle$ boundaries were addressed. Further experiments with $\langle 1010\rangle$ twist and $\langle 1120\rangle$ tilt boundaries are necessary to obtain a larger set of kinetics data and confirm the results obtained thus far. The misorientation dependence of grain boundary mobility then can be determined and compared for boundaries with twist and tilt character, which will lead to a better understanding of the mechanisms of grain boundary migration.

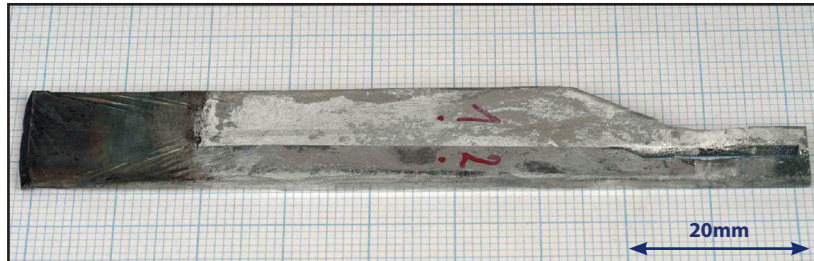

Figure 1.
Macro image of a $76^\circ\langle 1010\rangle$ bicrystal.

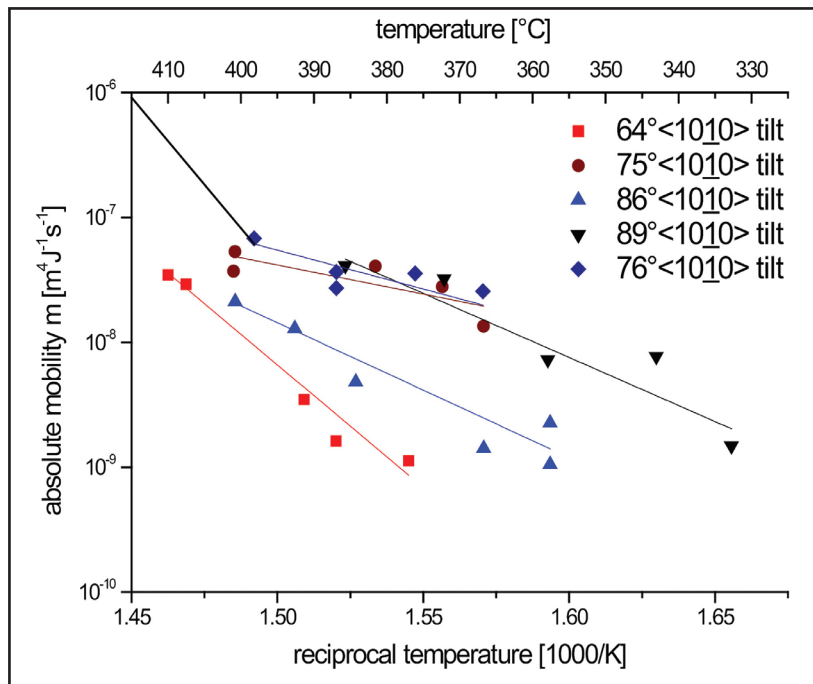

Figure 2.
Absolute mobilities of different tilt boundaries recorded in 2009.

ACKNOWLEDGEMENTS

This work was supported by Deutsche Forschungsgemeinschaft (Grant MO-848/6-2). The help of Scott Hannahs and his team is gratefully acknowledged.

REFERENCES

1. P. J. Konijnenberg, *et al.*, *Rev. Sci. Instr.*, **79**, 013701 (2008).
2. D. A. Molodov, *et al.*, *Acta Mater.*, **46**, 5627 (1998).
3. V. G. Sursaeva, *et al.*, *Fizika Met. Metall.*, **41**, 1013 (1976).

It is very challenging but essential to measure the distribution of infinitesimal amounts of water adsorbed to a solid sample in various applications. A team of scientists in the Magnet Lab and NASA demonstrated a unique potential of the recently upgraded ultra-wide-bore (UWB) 900 MHz MRI scanner to detect water adsorbed in paper. The experiments pave the way for further exploration in this direction.

MRI Evaluation of Adsorbed Water in Solids at 21.1 Tesla

J. Fesmire (NASA/KSC); S. W. Van Sciver, M. Vanderlaan, M. Barrios (Mag Lab/FSU, Mech. Eng.); V.D. Schepkin (Mag Lab/FSU, NMR)

INTRODUCTION

In a number of practical situations there is a critical need to evaluate the distribution of small amounts of water adsorbed throughout a solid sample. One of these pertains to Solid Foam Insulation (SOFI), a thermal insulation material used on liquid hydrogen and oxygen tanks on the Space Shuttle. The high MRI sensitivity of the Magnet Lab's 21.1 tesla (T) magnet and the ability to examine large volume samples represents a unique opportunity to perform this evaluation. There are, however, two problems with this task. First, the amount of water can be infinitesimal, which adds to the difficulties in performing the analysis. The other problem involves the inevitable water binding, which leads to subsequent short echo times (TE). It is well known that a typical MRI can provide a distribution map of free or slightly bound water having long echo times $TE \geq 1$ ms. By contrast, in the case of strong water binding, the needed TE times are dramatically less ($\sim 200 \mu\text{s}$). The standard MRI technique in this case is not suitable as it will yield a zero signal. The recent upgrade of the UWB 900 MHz MRI scanner (May 2009) allows for ultra-short TE two-dimensional MRI (UTE) performance. The present report demonstrates its unique potentials and current pitfalls.

EXPERIMENTAL

MR imaging was achieved using the vertical 21.1 T magnet equipped with a Bruker Avance III console operated by ParaVision 5.0. Actively shielded gradient coil (Mini-0.75, ID = 57 mm) was used during experiments together with a specifically designed radio frequency (RF) proton probe (900 MHz). The low moisture sample filled the entire volume of the RF coil (ID 33 mm) and was made of paper (Kimwipes Napkins) containing a small amount of water ($\sim 10\%$ of sample weight). MR images were acquired using new Bruker 2D UTE pulse sequence with an echo time $TE \sim 100 \mu\text{s}$ and $SW = 70$ kHz. The test MR images were taken as a projection along the RF coil, without slice selection, usually taking a few minutes to acquire.

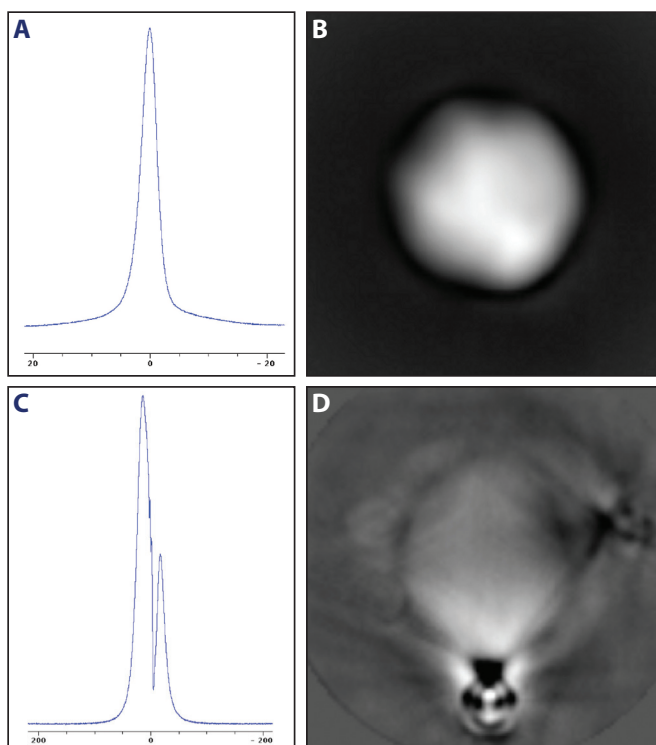

Figure 1.

MR proton spectra of water adsorbed in paper (A, scale ± 20 ppm) and empty RF coil (C, scale ± 200 ppm), RF pulse = $5 \mu\text{s}$. UTE MR images (FOV=80 mm) of adsorbed water (B) and empty RF coil (D).

RESULTS AND DISCUSSION

The level of water binding inside paper can be evaluated from the line width of the proton spectrum ~ 3 kHz (Figure 1A). The UTE MR image (Figure 1B) visualizes this type of bound water throughout the sample. For comparison, in water saturated SOFI, the line width is 2.6 kHz. Thus, a distribution of adsorbed water in this material can be detected. However, bound water in our trial experiment gives a strong MR signal. The ability of the UWB 900 MHz MRI scanner to detect a minute amount of water is limited now, as can be seen from an MR spectrum of the empty RF coil (Figure 1C, $NA = 4$). A wide line proton spectrum (~ 42 kHz) represents the RF coil manufacturing materials. The corresponding UTE MR image of the empty coil (Figure 1D) shows a background signal throughout FOV.

CONCLUSIONS

The ability to perform MRI of bound water with a line width of up to 3 kHz ($T_2 \sim 0.9$ ms) was demonstrated at 21.1 T. The current ultra short echo time MRI with $TE \sim 100 \mu\text{s}$ is expanding the area of imaging analysis that can be performed at the Magnet Lab. However, the first experiments also demonstrate that the residual signals from the RF coil materials can be comparable with a small amount of bound water in the samples. The creation of a new type of RF coil without background signals is a tricky but important step for future experiments in this area.

ACKNOWLEDGEMENTS

Thanks to C. Ralph (Mechanics Research Division, Southern Research Institute, Birmingham, AL) and G. Daspit (Nondestructive Characterization, Southern Research Institute) for interest and concerns in the development of MRI low moisture analysis for solid materials at UWB 900. Special thanks to Ashley Blue for his help during this project.

The 25-tesla (T) split magnet will provide a significant enhancement to the high-field user facility of the Magnet Lab. A split magnet provides access to the central field region radially through the magnet in addition to the conventional access down the bore, providing a large viewing angle for the sample region in the bore and making the magnet particularly suitable for photon scattering experiments. The magnet project now enters the next phase of construction, with a user available system projected for 2011.

• This work has been submitted to *IEEE Trans. Appl. Supercond.*

Design of the Magnet Lab Split Resistive User Magnet for Scattering

J. Toth, M.D. Bird, S. Bole, J. O'Reilly (Magnet Lab)

INTRODUCTION

The Magnet Lab has completed the design of all major components of a high-field split resistive magnet for use in far-infrared photon scattering experiments. The magnet includes four large scattering ports of elliptical shape at the mid-plane. Such a magnet configuration results in unique design challenges being especially severe for the windings in the mid-plane region of the innermost coils. Consequently, the Magnet Lab incorporated its newly developed technology called Split Florida-Helix previously tested at the lab with diverse working models¹. The user magnet, to be operated at the DC Field Facility in Tallahassee, will consist of five resistive coils consuming a total of less than 28 megawatts of DC power and providing a flux-density of at least 25 T available at the center of the user space. All coils employ axial current grading for field optimization and stress management. Advanced finite element analysis (FEA) served as the essential tool guiding the design optimization of the overall system and the various components. This report summarizes the work presented in much more detail in reference 2.

RESULTS AND DISCUSSION

The user magnet requires a traditional bore tube as well as four large scattering ports of elliptical shape to provide adequate experimental space at the mid-plane (each with an opening angle: horizontal= 45° /vertical= 11.4°). The magnet consists of five coils, with the two innermost coils (A1+A2) electrically in parallel and all other coils (B, C, D) electrically in series. The Split Florida-Helix is employed near the mid-plane (zones 1-3) of the two innermost coils, a less complicated split mid-plate (with elliptical shaped ports) is used at the mid-plane (zone 1) of all other coils and state-of-the-art Florida-Bitter technology elsewhere except the most

outer coil (D). To save tooling costs the significantly lower stressed (<200MPa) most outer coil (D) shares the traditional Bitter disc geometry of an existing lab magnet (B-coil of the Large Bore Magnet). As in most of our other high-performance solenoids, we incorporated axial current grading including a different cooling hole pattern (with elliptical cooling holes) for the end turns (last zone of each coil).

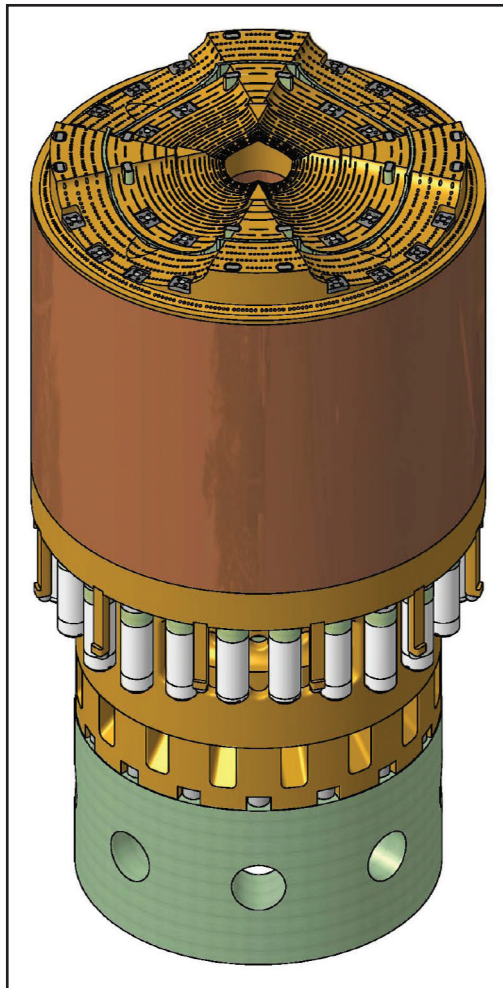

Figure 1.
3-D CAD model of the A/B-Coil Assembly of the Split user magnet (bottom half view cut at mid-plane for illustration).

CONCLUSIONS

The Magnet Lab completed the design of all major components of a large split user magnet suitable for use in far-infrared photon scattering experiments. The magnet is designed to provide a high magnetic field above 25 T consuming up to 28 MW of power. Next, the Magnet Lab plans to order materials and start fabrication in 2010 aiming to have the complete system available to users in the beginning of 2011.

ACKNOWLEDGEMENTS

This work was supported by the state of Florida and the National Science Foundation through NSF Cooperative Grant No. DMR 9016241.

REFERENCES

1. Toth, J., *et al.*, "FEA-aided Design for a Working Model of a Split Florida-Helix," *IEEE Trans. On Appl. Supercond.*, **18**, 2, pp. 575-578 (2008).
2. Toth, J., *et al.*, "FEA-aided Design of a Powered Scattering Magnet at the NHMFL," presented at MT-21, Oct. 18-23, 2009, Hefei, China, paper 1CP-21, to be published in *IEEE Trans. On Appl. Supercond.*, doi 10.1109/TASC.2010.2043423.

Whereas the solid state nuclear magnetic resonance (NMR) spectrum of low- γ quadrupolar nuclei has previously been shown to be a sensitive probe of metallocene structure and dynamics, these quadrupolar nuclei tend to exhibit poor sensitivity and very broad spectral line widths. To overcome these sensitivity issues, Mag Lab scientists in collaboration with Paul Ellis from the Northwest National Laboratory determined whether the 25 tesla (T) Keck resistive magnet could be used for NMR investigation of metal-bearing proteins, typically characterized by poor sensitivity and very broad spectral line widths. They report that the field inhomogeneity and instability of resistive magnets do not interfere with the acquisition of broad ^{35}Cl quadrupolar patterns recorded from metallocene dichloride samples using a combination of a quadrupolar Carr-Purcell Meiboom-Gill (QCPMG) signal enhancement experiment and field stepping.

• This work published in *Solid State Nucl. Mag. Reson.*, **36**, 159-163 (2009).

High-field QCPMG NMR of Large Quadrupolar Patterns Using Resistive Magnets

Ivan Hung, Kiran K. Shetty, William W. Brey, Zhehong Gan (Magnet Lab); Paul D. Ellis (Pacific Northwest National Laboratory)

INTRODUCTION

Metallocene compounds have been of great interest as both homogeneous and heterogeneous catalysts for olefin polymerization processes due to their single-site nature, which allows rational modification of their molecular structure in order to enhance catalytic performance or product selectivity. Many aspects of the catalytic processes that involve metallocenes remain poorly understood. Recent studies have shown that solid state NMR of low- γ quadrupolar nuclei provides a sensitive probe of metallocene structure and dynamics.¹ However, these quadrupolar nuclei tend to exhibit poor sensitivity and very broad spectral line widths. The successful application of high external magnetic fields with field stepping and the quadrupolar Carr-Purcell Meiboom-Gill (QCPMG) signal enhancement experiment is shown. This combination of methods also has great potential for the investigation of metal-bearing proteins, which also exhibit poor sensitivity and very broad spectral line widths.

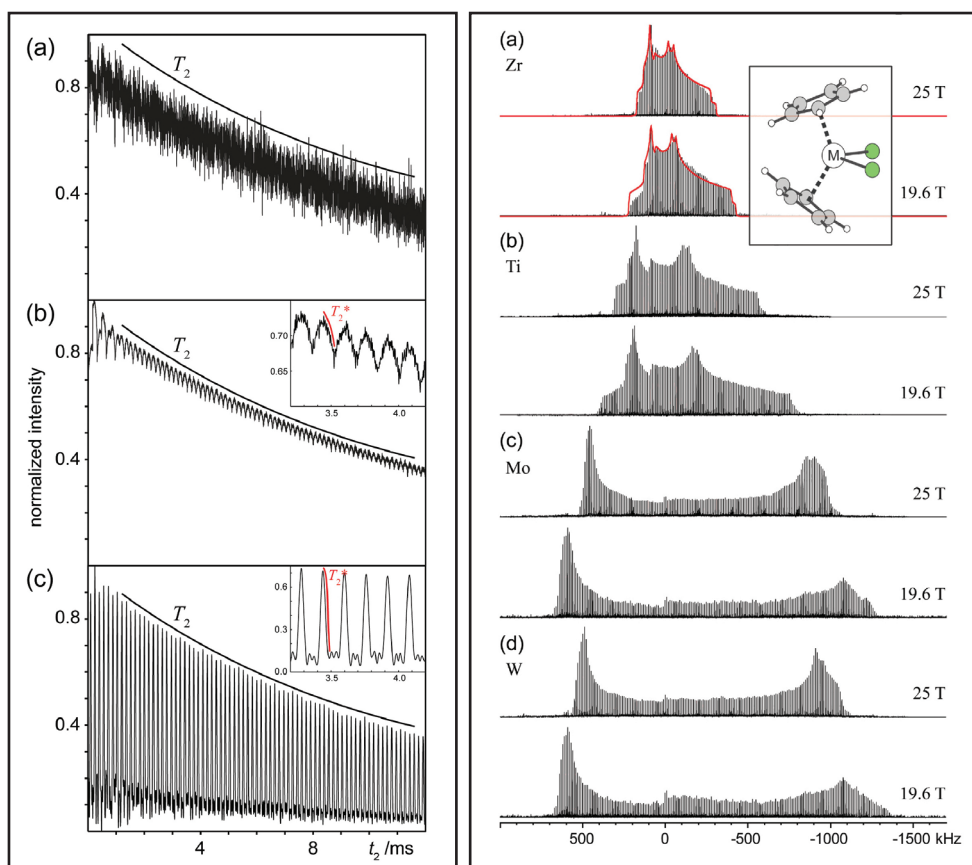

EXPERIMENTAL

Measurements were performed in the Keck 25 T, 52-mm bore resistive magnet at the Magnet Lab using a Tecmag Discovery console and a 19.6 T narrow bore superconducting magnet equipped with a Bruker DRX console. Field or frequency stepping in combination with the QCPMG pulse sequence was used to record the full breadth of the spectra.

RESULTS AND DISCUSSION

Solid-state NMR of low- γ quadrupolar nuclei suffers from intrinsic low signal sensitivity. Increasing the B_0 magnetic field can enhance spectral sensitivity dramatically and narrow the spectra of quadrupolar nuclei. The QCPMG experiment can provide further signal enhancement and counteract the effects of field fluctuation on the signal. Figure 1 (left) shows that the overall decay of the signal (T_2) is largely unaffected by field instability (a). A slight decay of the echoes is observed only upon longer averaging of the signal (b). This effect only becomes severe when the field is varied over a range of at least ~ 33 kHz (c). The ^{35}Cl NMR spectra of four metallocene dichloride samples acquired at 19.6 and 25 T are shown in Figure 2 (right). The spectra acquired using the 25 T resistive magnet show good agreement with those acquired using a 19.6 T superconducting magnet. A reduction in breadth of approximately 20%-25% is consistent with the decrease in second-order quadrupolar broadening due to the increase in field.

CONCLUSIONS

The field inhomogeneity and instability of resistive magnets do not interfere with the acquisition of broad quadrupolar patterns using a combination of the QCPMG experiment and field stepping. This holds much potential for the study of compounds with quadrupolar nuclei that reside in highly non-symmetric atomic sites.

ACKNOWLEDGEMENTS

This work has been supported by the User Collaboration Grants Program, and the National High Magnetic Field Laboratory through Cooperative Agreement (DMR-0084173) with the National Science Foundation and the state of Florida.

REFERENCES

1. Rossini, A.J., *et al.*, *Journal of the American Chemical Society*, **131**, 3317-3330 (2009).

To take full advantage of the increased signal-to-noise associated with high magnetic fields, the radio frequency (RF) technology needs to be matched optimally to the static field, which can be problematic with the specialized RF coils that are used for high-resolution imaging. For instance, magnetic resonance (MR) microscopy requires the use of small coils that at higher frequencies tend to have lossy components that interact with each other in restricted dimensions. In this report, external collaborators from the Pennsylvania State University tested the ability of ceramic dielectric resonators to work as ultra-high-field MR imaging coils. They found that ceramic dielectric resonators provide: (a) a more uniform magnetic field that excludes the electric field from the sample; (b) high Q values from the low dielectric loss of ceramics; and (c) increases in signal-to-noise ratio (SNR) when compared to more conventional but similarly sized copper resonators and over a range of sample loads.

MR Microimaging with a Cylindrical Ceramic Dielectric Resonator at 21.1 T

K. Haines (PSU, ECE); J.A. Muniz; I.S. Masad (FSU, Biomedical Engineering); E. Semouchkina (PSU, Mat Sci); M. Lanagan (PSU, Mat Sci); A.G. Webb (PSU, BioE); S.C. Grant (FSU-Magnet Lab, Biomedical Engineering)

INTRODUCTION

The recent development of high magnetic fields for both nuclear magnetic resonance (NMR) and MRI offers improvements in SNR, spatial resolution and image acquisition time for clinical/pre-clinical applications. MR microscopy requires small coils that at higher frequencies tend to have lossy components that may interact with each other in restricted dimensions. Previous work with dielectric resonators have shown relatively high Q values, good B_1 homogeneity, and increases in SNR in both electron paramagnetic resonance (EPR) and MRI^{1,2}. In this study, a ceramic dielectric resonator design is evaluated at 21.1 tesla (T).

EXPERIMENTAL

Imaging was performed on a 21.1-T, 105-mm ultra-wide-bore vertical magnet equipped with Bruker Avance III console and Micro2.5 microimaging gradients. The ceramic dielectric resonator (DR) was compared to Alderman-Grant (AG) and loop-gap (LG) coil configurations built with equal physical lengths and diameters (~4.5 mm). Calcium titanate (CaTiO_3 , $\epsilon_r = 156$) was chosen as the ceramic because of its high relative permittivity and low loss properties². Furthermore, this ceramic shows improvements in sample size, B_1 homogeneity, and ease of construction for MR microimaging over a previous design ($(\text{BaSr})\text{TiO}_3$, $\epsilon_r = 323$)². The samples were placed in a hole cored through the center of a cylindrical disk with dimensions specified to produce a resonant frequency of ~900 MHz. Biologically relevant samples with different loads, including deionized water (DI, 0-mM NaCl), phosphate buffered saline (1xPBS, 140-mM NaCl) and artificial seawater (ASW, 460-mM NaCl), were tested. Bench Q measurements, SNR and B_1 flip angle maps (indirect measure of the B_1 field homogeneity through double-angle methods) were used to evaluate performance at 900 MHz and for comparison between coils.

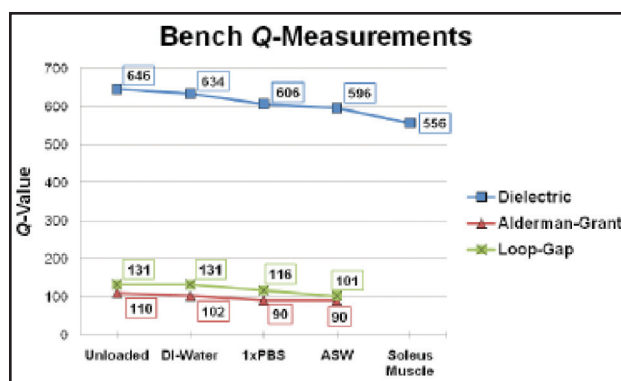

Figure 1.
Bench Q-Measurements of the different coils.

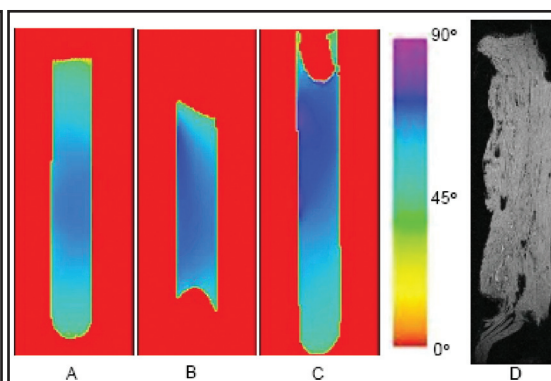

Figure 2.
(A, B, C) Flip angle maps of 1xPBS in DR, AG, & LG coils, respectively; (D) 20 μm isotropic 3D-FLASH image of excited rat soleus muscle using dielectric resonator.

RESULTS AND DISCUSSION

Q measurements (Figure 1) agree with values seen in a similar ceramic design at 600 MHz (14.1 T)¹ and only slightly decrease with heavier loads. The Q values for the DR are approximately fivefold higher than the AG and LG coils. Flip angle maps seen in Figure 2 validate the superior homogeneity of the DR. SNR data (not shown) indicate similar values of SNR in comparison to the other two coils, indicating that SNR improvements were not realized. However, when sample loading was increased, the SNR of the DR was consistent (in much the same fashion as the Q values) for all samples unlike the other coils, which displayed a drop in SNR with sample loading. Figure 2D shows a 3D image of an excised rat soleus muscle at 20 μm .

CONCLUSIONS

In order to reap the benefits of high-field MRI, coil design must be optimized to overcome electrical and sample effects present at higher frequencies. Ceramic dielectric resonators show promise by providing: (a) a more uniform magnetic field that excludes the electric field from the sample; (b) high Q values from the low dielectric loss of ceramics; and (c) increases in SNR when compared to more conventional but similarly sized copper resonators and over a range of sample loads. The work presented here shows an increase in DR performance compared to the previous design using the $(\text{BaSr})\text{TiO}_3$ ceramic ($Q \sim 600$ at 21.1 T and $Q \sim 500$) at 14.1 T². This increase can be attributed to the higher operating frequencies at 21.1 T (900 MHz). High-resolution 3D muscle tissue imaging at 20 μm (Figure 2D) displays a uniform distribution in signal without the appearance of any “hot spots.” This homogeneity agrees with the uniform distribution in B_1 field seen in flip angle maps.

ACKNOWLEDGEMENTS

Funding provided by the Magnet Lab through a User Collaboration Grant Program award to SCG.

REFERENCES

- Haines, K., et al. *J. Magn. Reson.*, **200**, 2 (2009).
- Neuberger, T., et al. *Conc. in MR*, **33B**, 2 (2008).

This work presents a cleverly designed tuning method for sodium imaging that takes full advantage of the unique opportunities the 900-MHz, ultra-wide-bore, 21.1-tesla (T) magnet provides MRI user community. The double-resonance birdcage coil for low- γ MRI maximizes sensitivity and radio frequency (RF) homogeneity over the range of sample loads, and minimizes trap losses for successful imaging of large rodents.

Efficient Double-Resonance Coil for Low- γ MRI of Large Rodent Brains at 21.1 Tesla

C. Qian (Magnet Lab); I. S. Masad (Magnet Lab and FSU Chemical and Biomedical Eng.); S. C. Grant (Magnet Lab and FSU Chemical and Biomedical Eng.); P. L. Gor'kov (Magnet Lab)

INTRODUCTION

The unique 900-MHz, ultra-wide-bore, 21.1-T magnet at the Magnet Lab provides great opportunities to the MRI community. Its high field is conducive to imaging of less sensitive low-gamma nuclei, such as sodium. Sodium imaging applications often require a 2-channel RF coil tuned to low ^{23}Na and high ^1H Larmor frequencies so that proton images can be co-registered with lower resolution sodium images to correlate structural and functional information. The emphasis in such coils is placed on maximizing sensitivity of the low- γ channel, RF homogeneity over the range of sample loads, and channel isolation while minimizing trap losses. We present a double-resonance birdcage coil with well insulated, efficient and homogeneous ^{23}Na and ^1H channels, designed for head-imaging of large rodents, such as rats or hamsters (ID = 33 mm).

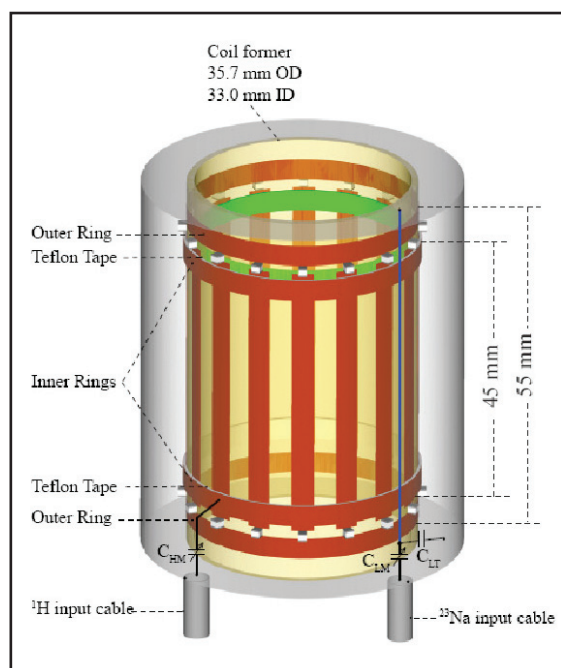

Figure 1.
The sliding ring coil for $^1\text{H}/^{23}\text{Na}$ MRI at 21 T.

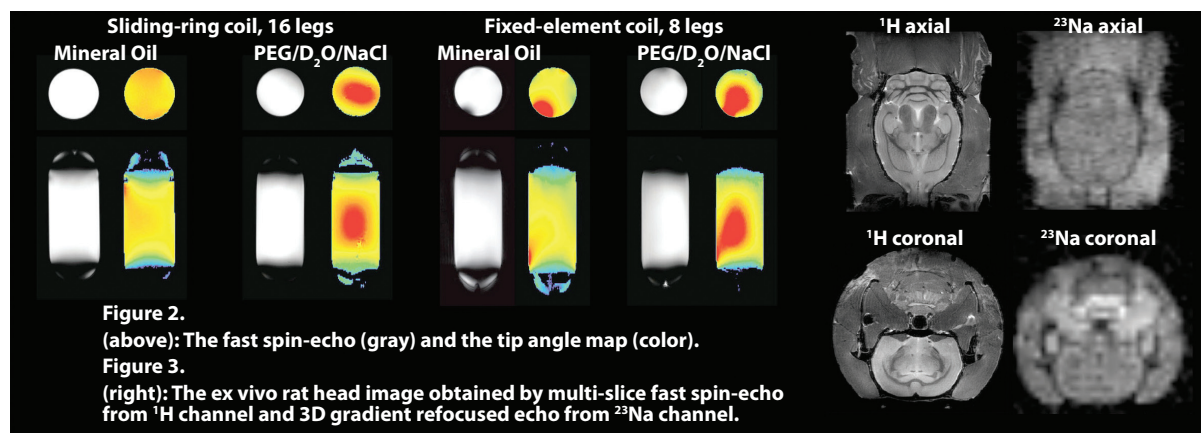

Figure 2.
(above): The fast spin-echo (gray) and the tip angle map (color).

Figure 3.
(right): The ex vivo rat head image obtained by multi-slice fast spin-echo from ^1H channel and 3D gradient refocused echo from ^{23}Na channel.

METHODS AND RESULTS

Conventional birdcage coils are often tuned with a trimmer capacitor across one leg. This convenient scheme, however, can disturb B_1 homogeneity at high ^1H frequencies as shown in Figure 2, especially if the coil is used with vastly different sample loads. To maintain azimuthal symmetry of ^1H B_1 fields, we used a sliding metal ring to vary the overlapping capacitance between the ring and the legs. Figure 2 shows image comparison for different samples in single-resonance ^1H coils. To achieve impedance matching for both samples, a conventional fixed-element coil of the same size cannot have more than 8 legs. The tuning range of a sliding-ring coil actually increases with the higher number of legs; it also yields more homogeneous images.

Figure 1 shows the physical implementation of the double-resonant sliding-ring birdcage coil. The coil is modified from a single-resonance ^{23}Na birdcage with the second resonance mode introduced by the capacitively coupled inner rings. A sliding ring (green) inserted inside the coil former is used as a symmetric ^1H frequency tuner that maintains B_1 homogeneity over a broader range of samples. The coil is driven capacitively at the ^1H frequency and inductively at the ^{23}Na frequency, achieving good isolation without the need for extra circuits (baluns or LC traps). A similar sliding-ring approach is used in our single-resonance ^1H coil.

Figure 3 shows the multi-nuclei *ex vivo* images obtained from an adult rat head. The ^1H images have an in-plane resolution of $115 \times 115 \mu\text{m}^2$ (5-minute acquisition time), which is sufficient to discern detailed anatomical structure. The sodium images have an isotropic resolution of 1 mm (9.5-minute acquisition time). When compared to the single-resonance birdcages, this double-resonance coil retains > 95% of sensitivity in the sodium channel and same sensitivity of the proton channel (the FOV of the proton channel is 70% that of a single-resonance ^1H coil). These favorable properties can facilitate the unambiguous co-registration of multi-nuclei images.

CONCLUSIONS

We constructed an efficient double-resonant ^1H - ^{23}Na coil for neuroimaging in large rodents. We expect this user facility instrumentation to enhance low- γ imaging capability at the Magnet Lab and exploit the advantages of high-field spectrometers for the MRI community. This work was highlighted by the Young Investigator Award in the 9th International Conference in Magnetic Resonance Microscopy in 2009.

ACKNOWLEDGEMENTS

This work has been supported by the Magnet Lab, which is funded by the NSF through Cooperative Agreement (DMR-0084173), and the state of Florida. C.Q. was supported by Bruker-Biospin Corp. Additional funding was provided by the User Collaborative Group Program award to S.C.G.

Using high field electron paramagnetic resonance (EPR), structural models were predicted for the complexation of Pb(II) in humic acids (river sediment). Knowing the complexation of Pb(II) in sediments could prove important in the tracking of Pb in the environmental flora and fauna. Knowing the complexation may also prove to be vital to the removal of these compounds in polluted environments.

• This work was published in *J. Phys. Chem. A*, **113**, 14115-14122 (2009).

Influence of Pb(II) Ions on the EPR Properties of the Semiquinone Radicals of Humic Acids and Model Compounds: High Field EPR and Relativistic DFT Studies

M. Witwicki, J. Jezierska, M. Jerzykiewicz, A. R. Jaszewski (Wroclaw University, Chemistry);
A. Ozarowski (Magnet Lab)

INTRODUCTION

The interaction of humic acids (HAs) with metal ions is particularly important as HAs together with clays and metal oxides are a key factor determining the metal binding in soils¹. Significant changes in the free radicals concentration resulting from the interaction of HAs with metal ions were observed, e. g. with Mg^{2+} , Cu^{2+} , Ca^{2+} , Zn^{2+} , or Cd^{2+} . However, a completely different effect is observed for Pb^{2+} ions. The complexation of Pb^{2+} with HA macromolecules leads to formation of a new kind of stable radical species characterized by unusually low g values ($g \approx 2.001$)^{2,3}.

EXPERIMENTAL

High-field and frequency EPR spectra (416.00 GHz) were recorded on the transmission instrument at the Magnet Lab EMR facility. All computations were performed by using the ADF suite of programs⁴ as described in ref. 5.

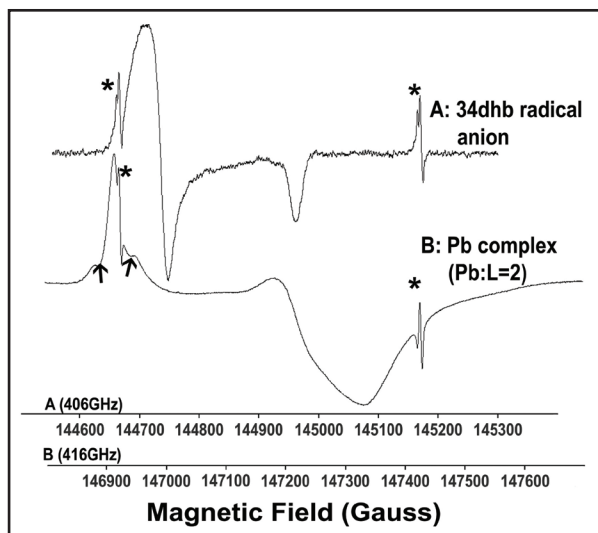

Figure 1.

High-field EPR spectrum of model 34dhb radical and its Pb(II) complex at 10 K. The arrows indicate the hyperfine splitting due to ²⁰⁷Pb

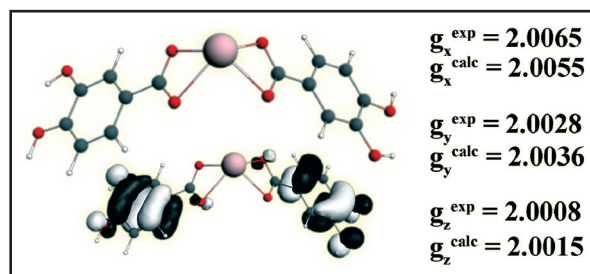

Figure 2.

Proposed model of the 34dhb-Pb(II) system, showing the spin density.

RESULTS AND DISCUSSION

The formation of Pb(II) complexes with the model radicals derived from 3,4-dihydroxybenzoic acid (34dhb) was accompanied by a significant decrease of g as compared to the parent radicals. The Density Functional Theory calculations, including prediction of the g -tensors, were carried out for complexes with different forms of model radical ligands (L^{2-} , HL^- , and H_2L) representing various ligation schemes and protonation states. It was shown that the structures with a significant accumulation of spin population on the Pb atom cannot explain the experimentally observed g -tensor component shifts.

CONCLUSIONS

The determination of the g -tensor components for model systems was possible only from high-frequency and high-field EPR measurements (Figure 1) at low temperatures. Formation of two complexes was revealed by two different high-field EPR spectra characterized by dissimilar g -tensor patterns. For one of them, the splitting due to an anisotropic hyperfine interaction with the ²⁰⁷Pb nucleus (71.6 G) was observed. The comparison of the computed and experimental g -tensor components indicates that only the decrease of spin population on all oxygen atoms accompanied by a corresponding spin population increase on the carbon atoms of the benzoic ring can reproduce the experimental results (Figure 2), thus supporting strongly the prediction of the Pb(II) complex geometry.⁵

ACKNOWLEDGEMENTS

All computations were performed on computers of the Wrocław Center for Networking and Supercomputing (Grant No. 48). High-field EPR spectra were recorded at the Magnet Lab, which is funded by the NSF through the Cooperative Agreement No. DMR-0654118, by the state of Florida, and by the DOE. This work was financially supported by MNiSW (Grant No. 2PO4G 06 30).

REFERENCES

1. Tipping, E., in *Cation Binding by Humic Substances*, first edn., Cambridge University Press, Cambridge, 2002.
2. Giannakopoulos, E., et al., *J. Phys. Chem. A*, **109**, 2223 (2005).
3. Jerzykiewicz, M., *Geoderma*, **122**, 305 (2004).
4. Amsterdam Density Functional (ADF) 2007.01, SCM, Theoretical Chemistry, Vrije Universiteit, Amsterdam, The Netherlands.
5. Witwicki, M., et al., *J. Phys. Chem. A*, **113**, 14115-14122 (2009).

Copper(I) and copper(II) perfluorocarboxylates are volatile, which makes them potentially useful in the chemical vapor deposition technique to produce thin metallic copper layers. Determination of the nuclearity of such complexes is very important for consistent deposition. The use of high-field electron paramagnetic resonance (EPR) spectroscopy has enabled studies of some unprecedented solid-state transformations of dimeric and tetrameric complexes of copper(II) perfluorocarboxylates. In one example, an antiferromagnetic dimer converts reversibly to a tetramer; in a second example, an irreversible solid-state conversion of a ferromagnetic tetramer into an antiferromagnetic tetramer is seen. These systems exhibited the largest zero-field splitting ever observed in a polynuclear copper complex, which is why they could only be studied thanks to the remarkably high frequencies (up to 1 THz; 432 GHz in this case) and magnetic fields available at the Magnet Lab.

• This work was published in *J. Am. Chem. Soc.*, **131**, 10279-10292 (2009).

High-Field EPR and Magnetic Susceptibility Studies on Tetranuclear Ferromagnetic Quinoline Adducts of Copper(II) Trifluoroacetate

I. B. Szymańska, T. Muzioł (Nicolaus Copernicus U., Chemistry); J. Jezierska (Wrocław U., Chemistry); A. Ozarowski (Magnet Lab)

INTRODUCTION

While dimeric “paddlewheel” structures are very conspicuous among copper(II) complexes of formic acid and its homologues, such arrangements are much less numerous in the case of the perfluorinated carboxylic acids, which tend to form either monomeric copper complexes or extended chains.¹ Copper(I) and copper(II) perfluorocarboxylates are volatile which makes them potentially useful in the chemical vapor deposition technique to produce thin metallic copper layers,² and from that viewpoint the determination of nuclearity of such complexes is very important. In this work, magnetic properties and high-field EPR spectra of three previously unknown tetranuclear quinoline adducts of copper(II) trifluoroacetate were studied and their X-ray structures were determined.

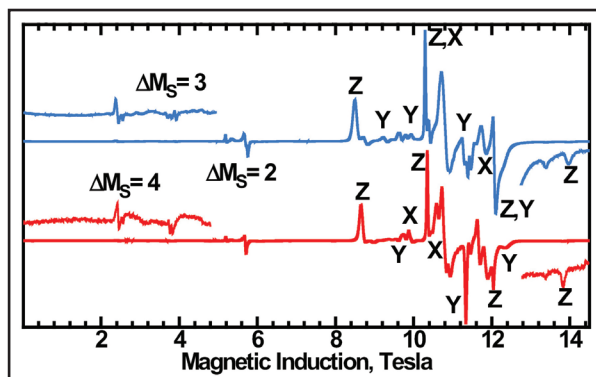

Figure 1.

EPR spectra of the toluene (bottom) and benzene (top) solvate of $\text{Cu}_2\text{O}(\text{CF}_3\text{COO})_6(\text{quinoline})_4$ at 15 K and 324 GHz. Both compounds exhibited identical g values $g_x = 2.168$, $g_y = 2.173$, $g_z = 2.066$, but differed in zero-field splitting parameters $D = -0.827$, $E = -0.114$ and $D = -0.875$, $E = -0.049 \text{ cm}^{-1}$ for the toluene and benzene solvate, respectively.

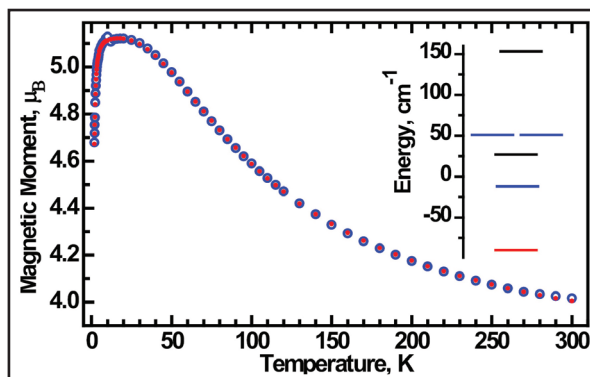

Figure 2.

Experimental (blue) and calculated (red) magnetic moment of $\text{Cu}_2\text{O}(\text{CF}_3\text{COO})_6(\text{quin})_4$. The inset shows energies of the spin states: red: $S = 2$, blue: $S = 1$, black: $S = 0$.

EXPERIMENTAL

High-field and frequency EPR spectra were recorded on the 15 /17 tesla (T) transmission instrument at the Magnet Lab EMR facility at microwave frequencies 52-432 GHz and magnetic fields up to 15 T. Magnetic susceptibility data of powdered samples were measured with a SQUID magnetometer (Quantum Design MPMSXL-5) over the temperature range 1.8–300 K.

RESULTS AND DISCUSSION

Very well resolved EPR spectra due to a quintet ($S = 2$) spin state were observed for the tetrameric complexes (Figure 1). The magnetic properties (Figure 2) were interpreted by using the Heisenberg-Dirac-Van Vleck Hamiltonian

$$H = J_1(\mathbf{S}_1\mathbf{S}_2 + \mathbf{S}_3\mathbf{S}_4) + J_2(\mathbf{S}_1\mathbf{S}_3 + \mathbf{S}_1\mathbf{S}_4 + \mathbf{S}_2\mathbf{S}_3 + \mathbf{S}_2\mathbf{S}_4) \quad [1]$$

$J_1 = -102 \text{ cm}^{-1}$, $J_2 = -39 \text{ cm}^{-1}$ were found.

CONCLUSIONS

Terms describing the Zeeman and zero-field splitting, which were derived from the high-field EPR spectra (Figure 1), had to be added to properly reproduce the magnetic susceptibility at the lowest temperatures. "Broken symmetry" Density Functional Theory (DFT) calculations³ were performed to estimate the exchange integrals resulting in $J_1 = -115 \text{ cm}^{-1}$ and $J_2 = -56 \text{ cm}^{-1}$, in a surprisingly good agreement with experimental results. The results of this work were published in the *Journal of the American Chemical Society*.⁴

ACKNOWLEDGEMENTS

This work was supported by the Magnet Lab, which is funded by the NSF through the Cooperative Agreement No. DMR-0654118, the state of Florida and the DOE, and by the Ministry of Science and Higher Education of Poland through the grant N204 049 31/1376.

REFERENCES

1. Cotton, F. A., *et al.*, *Inorg. Chem.*, **39**, 6072-6079 (2000).
2. Grodzicki, A., *et al.*, *E. Coord. Chem. Rev.*, **249**, 2232-2258 (2005).
3. Neese, F., ORCA – An Ab initio, DFT, and Semiempirical Electronic Structure Package, University of Bonn, 2007.
4. Ozarowski, A., *et al.*, *J. Am. Chem. Soc.*, **131**, 10279-10292 (2009).

Sodium and calcium naphthenate formation in crude oil production can badly foul oil/water separators and refinery plumbing and result in unplanned shut downs. High-resolution Fourier transform ion cyclotron resonance mass spectrometry (FT-ICR MS) directly identifies and speciates the compounds responsible for calcium and sodium naphthenate deposits. This novel high-resolution methodology has enabled the development of crude oil screening assays to test for potential naphthenate deposition issues prior to crude-oil production.

• This work was published in *Energy & Fuels*, **23**, 349-355 (2009).

Chemical Speciation of Calcium and Sodium Naphthenate Deposits by Electrospray Ionization FT-ICR Mass Spectrometry

M. M. Mapolelo (FSU, Chemistry), L. A. Stanford (FSU, Chemistry); R. P. Rodgers (FSU, Magnet Lab, Chemistry); A. T. Yen (Baker Hughes, Sugar Land, TX); J. D. Debord (Baker Hughes, Sugar Land, TX); S. Asomaning (Baker Hughes, Sugar Land, TX); A. G. Marshall (FSU, Magnet Lab, Chemistry)

INTRODUCTION

Calcium and sodium naphthenates are solid deposits and emulsions formed by the interaction of naphthenic acids with divalent (Ca^{2+} , Mg^{2+}) or monovalent (Na^+ , K^+) ions in produced waters. Calcium naphthenate formation, an interfacial phenomenon, is thought to depend largely on tetraprotic naphthenic acids known as "ARN" acids ($\sim \text{C}_{80}$) in the crude oil, whereas sodium naphthenates originate from lower molecular weight ($\text{C}_{15} - \text{C}_{35}$) monoprotic naphthenic acids. We have produced detailed chemical heteroatom class composition analyses of calcium and sodium naphthenates from the field based on ultra-high-resolution FT-ICR MS. In all cases, calcium naphthenate deposits consist predominately of tetraprotic acids with a C_{80} hydrocarbon skeleton, whereas sodium naphthenate emulsions consist mainly of specific monoprotic saturated carboxylic acids. Furthermore, low molecular weight tetraprotic (ARN) acids with C_{60-77} hydrocarbon skeletons were identified in the calcium naphthenate deposit. The high resolution and mass accuracy of FT-ICR MS provide detailed acidic speciation for the analyzed deposits and emulsions.

EXPERIMENTAL

Electrospray ionization mass spectra were acquired with the Magnet Lab 9.4 tesla (T) custom-built FT-ICR mass spectrometer. The figure clearly shows that sodium naphthenates are saturated alkyl carboxylic acids (the only double bond to carbon is the carbonyl).

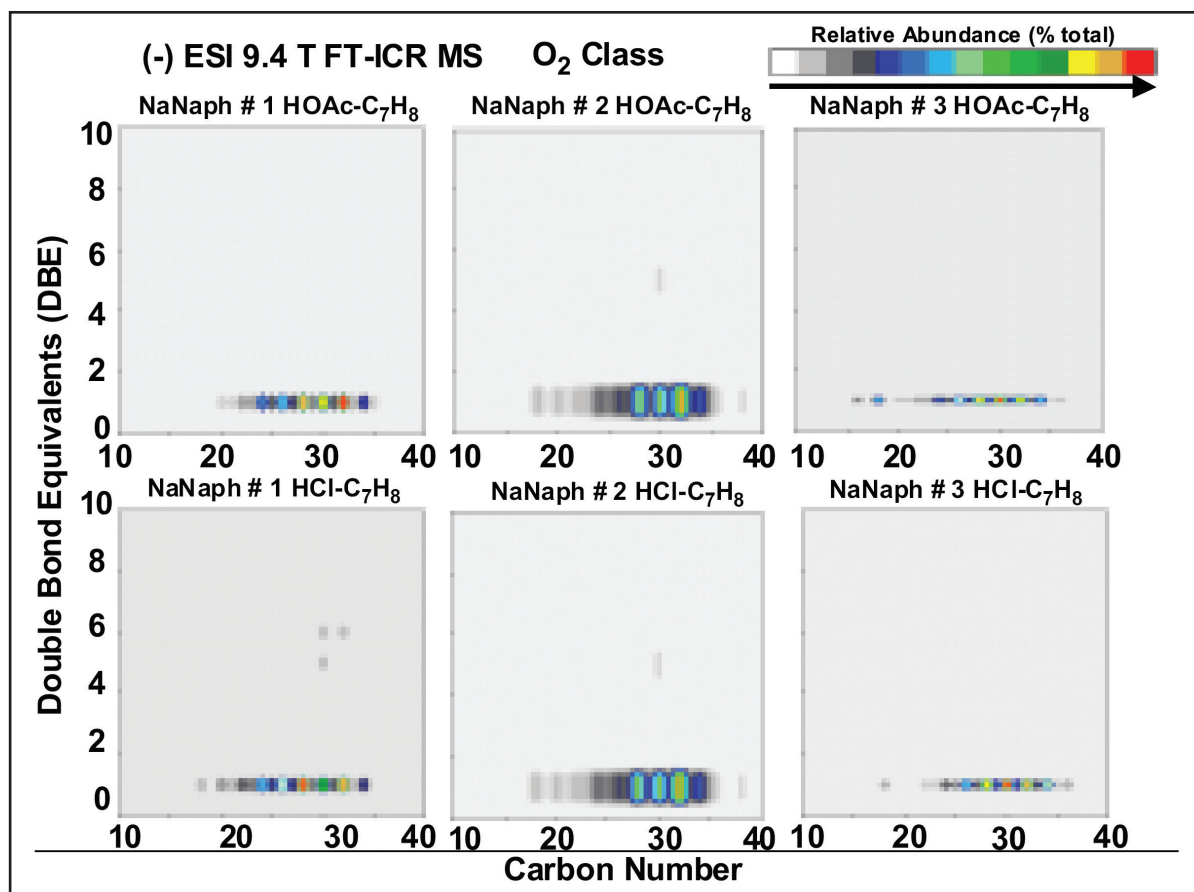

ACKNOWLEDGEMENTS

This work was supported by NSF Division of Materials Research through DMR-0654118 and the state of Florida.

REFERENCE

1. Mapolelo, M. M., *et al.*, *Energy & Fuels*, **23**, 349-355 (2009).

A sharply improved two-dimensional separation produces rapid (one-hour), reproducible, robust fractionation of proteins prior to top-down mass spectrometry (i.e., starting from an intact gas-phase protein, so that all chemical modifications may be identified by collision-induced fragmentation). Ultra-high-resolution, high-field Fourier transform ion cyclotron resonance mass spectrometry (FT-ICR MS) provides unambiguous identification of the nature and site(s) of chemical modifications that tune the function of a protein. This powerful approach is demonstrated for phosphorylation of 5 – 25 kDa proteins in M phase arrested HeLa cells with nanocapillary liquid chromatography (LC) MS/MS. Single injections give ~40 detectable proteins, about half which yield automated (ProSight) identifications.

• This work was published in *J. Am. Soc. Mass Spectrom.*, **20**, 2183-2191 (2009).

A Robust Two-Dimensional Separation for Top-Down Tandem Mass Spectrometry of the Low Mass Proteome

J. E. Lee (U. Illinois Urbana, Chemistry); J. F. Kellie (U. Illinois); J. C. Tran (U. Illinois); J. D. Tipton (Magnet Lab); A. C. Catherman (U. Illinois); H. M. Thomas (U. Illinois); D. R. Ahlf (U. Illinois); K. R. Durbin (U. Illinois); A. Vellaichamy (U. Illinois); I. Ntai (U. Illinois); A.G. Marshall (FSU, Magnet Lab, Chemistry); N. L. Kelleher (U. Illinois)

INTRODUCTION

For fractionation of intact proteins by molecular weight, a sharply improved two-dimensional (2D) separation is presented to drive reproducible, robust fractionation prior to top-down mass spectrometry of complex mixtures. The approach is implemented by use of tris-glycine and tris-tricine gel systems applied to human cytosolic and nuclear extracts from HeLa S3 cells to achieve a molecular weight-based fractionation of proteins from 5 to >100 kDa in one hour. For top-down MS/MS of the low mass proteome (5-25 kDa), between five and eight gel elution (GE) fractions are sampled by nanocapillary-LC-MS/MS with 12 T or 14.5 T FT-ICR mass spectrometers. Single injections give ~40 detectable proteins, about half which yield automated ProSight identifications. Reproducibility metrics of the system are presented in Ref. 1, along with comparative analysis of protein targets in mitotic vs. asynchronous cells.

EXPERIMENTAL

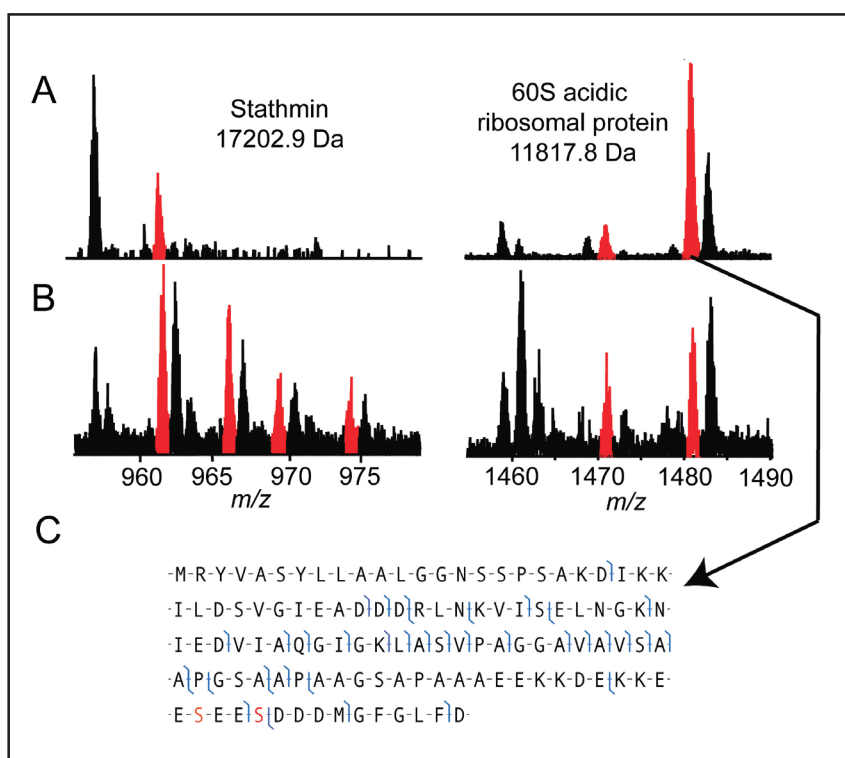

Electrospray ionization mass spectra were acquired with the 12 T ThermoFisher (UI) and 14.5 T (Magnet Lab) custom-built linear quadrupole trap/ FT-ICR mass spectrometers. The figure shows differences in phosphorylation for proteins identified in asynchronous and M phase arrested HeLa cells. In **A**, asynchronous HeLa proteins are identified with the phosphorylations designated in red. In panel **B**, M phase arrested HeLa proteins are identified, again with phosphorylations designated in red. Dynamic changes in phosphorylation between asynchronous and M phase arrest HeLa cells are clearly apparent. Panel **C** shows a fragment map for the doubly phosphorylated 60S acidic ribosomal protein (phosphorylation sites in red).

ACKNOWLEDGEMENTS

The authors thank the Magnet Lab's C. L. Hendrickson, M. R. Emmett, J. P. Quinn, and G. T. Blakney for helpful discussion, and Mingxi Li for helping with sample preparations. Work supported by NSF (DMR-0654118), the state of Florida, the Packard Foundation, the Sloan Foundation, NIH (GM 067193-07), and the UIUC Neuroproteomics Center on Cell-Cell Signaling supported by NIDA (P30 DA018310-06).

REFERENCE

1. Lee, J. E., *et al.*, *J. Am. Soc. Mass Spectrom.*, **20**, 2183-2191 (2009).

The hydrochloride salts (HCl) of many pharmaceuticals are essential for solubility and biological absorption of the active compound. High-field (900 MHz) nuclear magnetic resonance (NMR) shows increased resolution and isolation of quadrupolar and chemical shielding parameters in HCl pharmaceuticals. The application of high-field NMR is advantageous for the determination of compound purity for HCl pharmaceuticals especially when standard methods, such as X-ray diffraction, fail.

Solid-State ^{35}Cl NMR Spectroscopy of a Variety of Hydrochloride Pharmaceuticals

H. Hamaed (University of Windsor [UW], Windsor, Canada), M. Laschuk (UW), Riqiang Fu (Magnet Lab), and R. W. Schurko (UW)

INTRODUCTION

Hydrochloride drugs constitute more than 50% of pharmaceutical salts and chlorine is present in approximately 25% of drugs. The abundance of chlorine in many pharmaceuticals makes ^{35}Cl solid-state nuclear magnetic resonance (SSNMR) a very useful probe for structural characterization of a variety of Cl-containing drugs. In our previous publication,¹ we demonstrated that ^{35}Cl SSNMR spectroscopy is a powerful complimentary technique to powder X-ray diffraction (XRD) and ^{13}C SSNMR experiments for the study of pharmaceutical polymorphs. It provides clear information on the number of chlorine sites and shows great utility for identifying sites in non-crystalline, disordered or even impurity phases, especially in cases where the solid-state ^{13}C NMR spectra or powder XRD data are unable to differentiate polymorphs. Our previous work also has shown that the use of ultra-high-field NMR spectrometers is crucial for the success of this research, for both fast acquisition of high signal-to-noise ratio NMR spectra and accurate determination of anisotropic quadrupolar and chemical shift parameters. The sensitivity of the ^{35}Cl chemical shift (CS) and electric field gradient (EFG) tensors to subtle changes in the chlorine environments is reflected in the ^{35}Cl SSNMR powder patterns. The ^{35}Cl NMR data can be analyzed to obtain NMR parameters such as the quadrupolar coupling constant and asymmetry parameters, as well as the anisotropic chemical shift parameters. These parameters can be modeled via first principles calculations to lend insight into the local Cl environments. Due to the usefulness of the ^{35}Cl SSNMR in identifying different polymorphs and in characterization of chlorine-containing drugs, we are extending this research to include a variety of HCl pharmaceuticals. We hope to demonstrate that ^{35}Cl SSNMR experiments can act as accurate and rapid probes of chlorine ion environments in a variety of pharmaceuticals, particularly where crystal structures are unavailable. We also hope to make SSNMR a primary technique for examining different classes of pharmaceuticals, as well as acting as a rapid fingerprinting tool during drug processing and manufacture.

EXPERIMENTAL

^{35}Cl SSNMR experiments were carried out on a Varian Infinity Plus spectrometer with an Oxford 9.4 tesla (T) wide-bore magnet using 5 mm HX static probe at the University of Windsor. High-field ^{35}Cl NMR data were collected on an ultra-wide-bore 900 MHz (21.1 T) magnet (Magnet Lab) using a 3.2 mm magic angle spinning (MAS) HX probe and flat coil HX static probe.

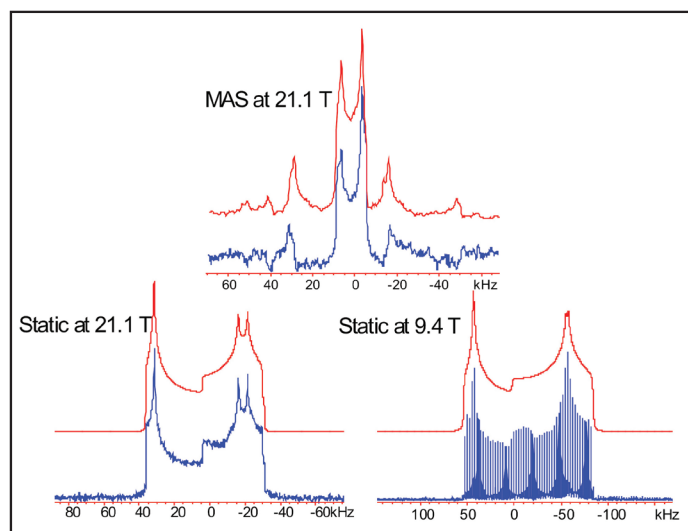

Figure 1. ^{35}Cl MAS and static NMR spectra and simulations of Adiphenine HCl at two different fields.

RESULTS AND DISCUSSION

The ^{35}Cl NMR spectra of adiphenine HCl (AH) (Figure 1) reveal a single chlorine site, in agreement with the crystal structure. Experiments at 21.1 T are crucial for (i) obtaining high-resolution MAS NMR patterns and (ii) isolating anisotropic CS parameters. Simulations reveal quadrupolar coupling constants, C_Q , of 5.94 MHz, and asymmetry parameter, η_Q , of 0.18. These parameters are consistent with a chlorine site involved in a single H-bond contact.

CONCLUSIONS

The sensitivity of the ^{35}Cl EFG and CS tensor parameters to the chlorine environments holds much promise for application to a wide variety of HCl pharmaceuticals and this technique should be very useful, particularly in the case of non-crystalline or amorphous samples where XRD cannot be applied.

ACKNOWLEDGEMENTS

Discovery Grant, NSERC, Canada; Infrastructure grant, CFI, Canada; Infrastructure grant, OIT, Ontario; ERA grant, Ontario Ministry of Research and Innovation; CCMR, University of Windsor.

REFERENCES

1. H. Hamaed, *et al.*, *JACS*, **130**, 11056 (2008).

The majority of active therapeutic compounds are of biological origin. The marine environment has produced many active compounds, such as bryostatins isolated from brown algae, which are synergistic anticancer agents. Thus, there is a precedent to search other marine life for potential therapeutics. NMR has a great advantage for discovery of these compounds because it can provide potential structural information for the medicinal chemist. This preliminary work suggests 10 biologically active compounds from marine cyanobacteria.

- This work was published in four different journals. See references for a full list.

Exploiting Marine Cyanobacteria for Drug Discovery

J. C. Kwan (UF, Medicinal Chemistry); K. Taori (UF, Medicinal Chemistry); S. Matthew (UF, Medicinal Chemistry); V. J. Paul (Smithsonian Marine Station); H. Luesch (UF, Medicinal Chemistry)

INTRODUCTION

Marine cyanobacteria are known to produce a variety of novel bioactive compounds, for the purpose of defense against herbivores. Our research is focused on discovering new bioactive cyanobacterial metabolites that could serve as novel drug leads. We extensively use samples collected in Florida, because the state has unparalleled marine biodiversity in the United States, and samples from other tropical areas, such as Guam.

EXPERIMENTAL

^1H , ^{13}C , and two-dimensional nuclear magnetic resonance (NMR) spectra were recorded on Bruker Avance NMR spectrometers (500 MHz, 2.5 mm probe; 600 MHz, 5 mm probe) or a Bruker Avance II 600 MHz spectrometer (1 mm HTS cryogenic probe or 5 mm TXI cryogenic probe).

RESULTS AND DISCUSSION

Samples of various marine cyanobacteria were collected from sites off the coast of Florida and from Guam. *Lyngbya confervoides* collected off Grassy Key, FL yielded grassystatins A–C, which were shown to selectively and potently inhibit the proteolytic enzyme cathepsin E and to reduce antigen presentation by human dendritic cells (Figure 1).¹ A separate collection of *L. confervoides* off Fort Lauderdale was found to contain tiglicamides A–C, inhibitors of porcine pancreatic elastase.² Other elastase inhibitors, lyngbyastatins 8–10, were found in a sample of *L. semiplena* collected in Guam.³ Finally, a sample of *Symploca sp.* collected off Key Largo afforded symplostatins 4, a cytotoxic microtubule disrupter that synergizes with largazole (see 2008 report).⁴

CONCLUSIONS

We continue to discover novel bioactive metabolites from marine cyanobacteria.

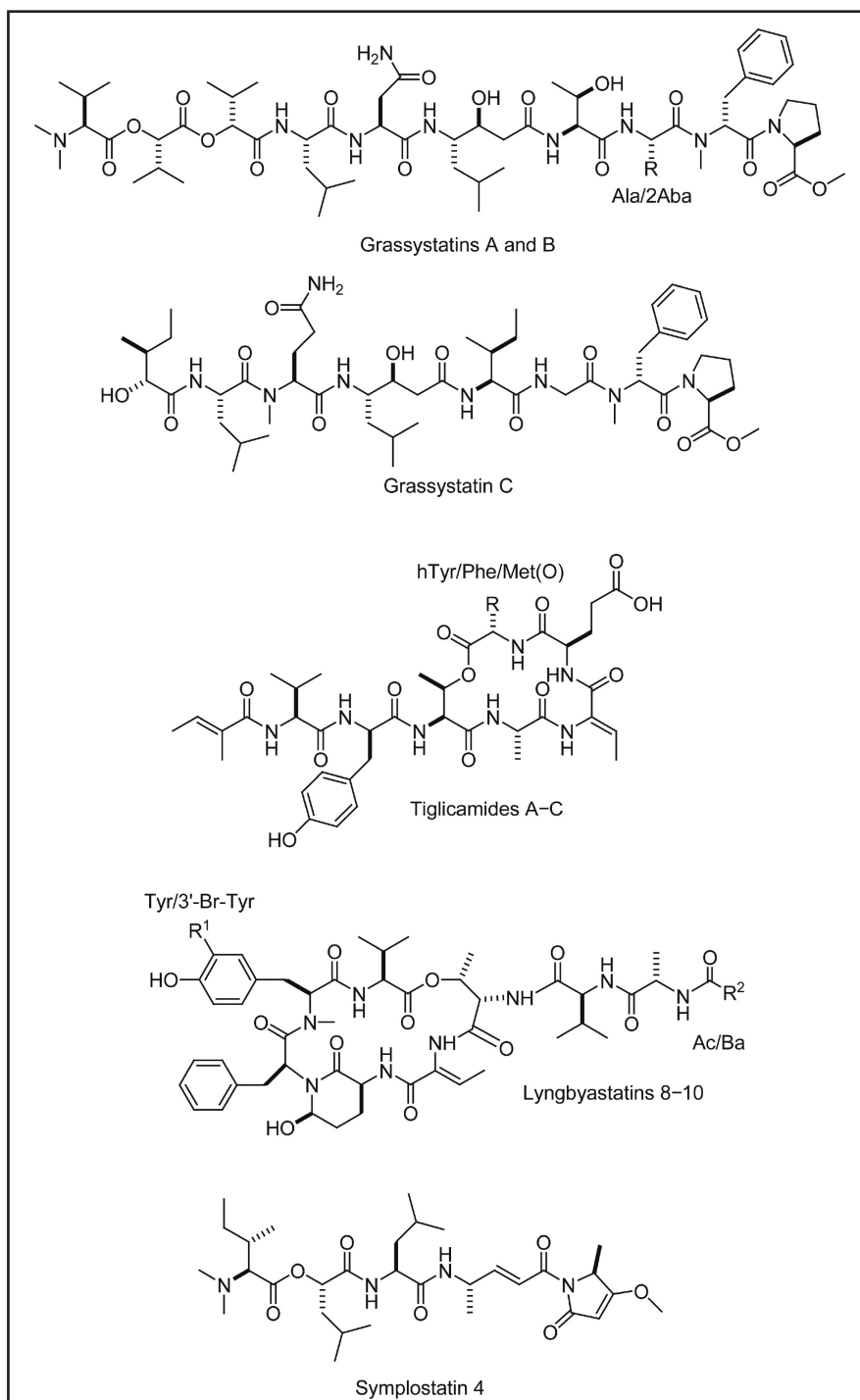

Figure 1.
Structures of grassystatins A–C, tiglicamides A–C, lyngbyastatins 8–10 and symplostatin 4.

ACKNOWLEDGEMENTS

National Institutes of Health, NIGMS Grant P41GM086210, Florida Sea Grant College Program (NA06OAR4170014), University of Florida College of Pharmacy, External User Program of the Magnet Lab at AMRIS (NSF), and J. R. Rocca.

REFERENCES

1. Kwan, J.C., *et al.*, *Journal of Medicinal Chemistry*, **52**, 5732-5747 (2009).
2. Matthew, S., *et al.*, *Phytochemistry*, **70**, 2058-2063 (2009).
3. Kwan, J.C., *et al.*, *Marine Drugs*, **7**, 528-538 (2009).
4. Taori, K., *et al.*, *ChemBioChem*, **10**, 1634-1639 (2009).

High field ion cyclotron resonance (ICR) enabled this multidisciplinary collaborative effort to determine a novel structural and enzymologic explanation for the resistance profile observed with the KIT inhibitors (imatinib and sunitinib) used to treat gastrointestinal stromal tumors (GISTs). Many GIST patients become resistant to imatinib and sunitinib through a mutation of the KIT kinase. Hydrogen/deuterium exchange (HDX) with high-resolution Fourier transform-ICR mass spectrometry analysis defined the conformational change of the mutant KIT kinase, which explained the drug resistance and aids in the design of more effective drugs to treat GIST patients. Moreover, HDX with high-resolution FT-ICR analysis established no change in the conformation of wild-type kinase and that of the wild-type kinase with deletion of the 60 amino acid kinetic insertion domain (KID). KID deletion was necessary to obtain crystals for X-ray diffraction analysis. The HDX data thus validated the X-ray diffraction results in the enzyme with the KID deletion.

• This work was published in the *Proc. Natl. Acad. Sci. U.S.A.*, **106**, 1542-1547 (2009).

KIT Kinase Mutants Show Novel Mechanisms of Drug Resistance to Imatinib and Sunitinib in Gastrointestinal Stromal Tumor Patients

K. S. Gajiwala, J. C. Wu, J. Christensen, G. D. Deshmukh, W. Diehl; J. P. DiNitto, J. M. English, M. J. Greig, Y.-A. He, S. L. Jacques, E. A. Lunney, M. McTigue, D. Molina, T. Quenzer, P. A. Wells, X. Yu, Y. Zhang, and A. Zou (Pfizer); M. R. Emmett, A. G. Marshall (Magnet Lab-FSU, Chemistry); H.-M. Zhang (FSU Molecular Biophysics); G. D. Demetria (Dana-Farber/Harvard Cancer Center)Introduction

Most gastrointestinal stromal tumors (GISTs) exhibit aberrant activation of the receptor tyrosine kinase (RTK) KIT. The efficacy of the inhibitors imatinib mesylate and sunitinib malate in GIST patients has been linked to their inhibition of these mutant KIT proteins. However, patients on imatinib can acquire secondary KIT mutations that render the protein insensitive to the inhibitor. Sunitinib has shown efficacy against certain imatinib-resistant mutants, although a subset that resides in the activation loop, including D816H/V, remains resistant. Biochemical and structural studies were undertaken to determine the molecular basis of sunitinib resistance. Our results show that sunitinib targets the auto-inhibited conformation of wild-type KIT and that the D816H mutant undergoes a shift in conformational equilibrium toward the active state. These findings provide a novel structural and enzymologic explanation for the resistance profile observed with the KIT inhibitors. Prospectively, they have implications for understanding oncogenic kinase mutants and for circumventing drug resistance.

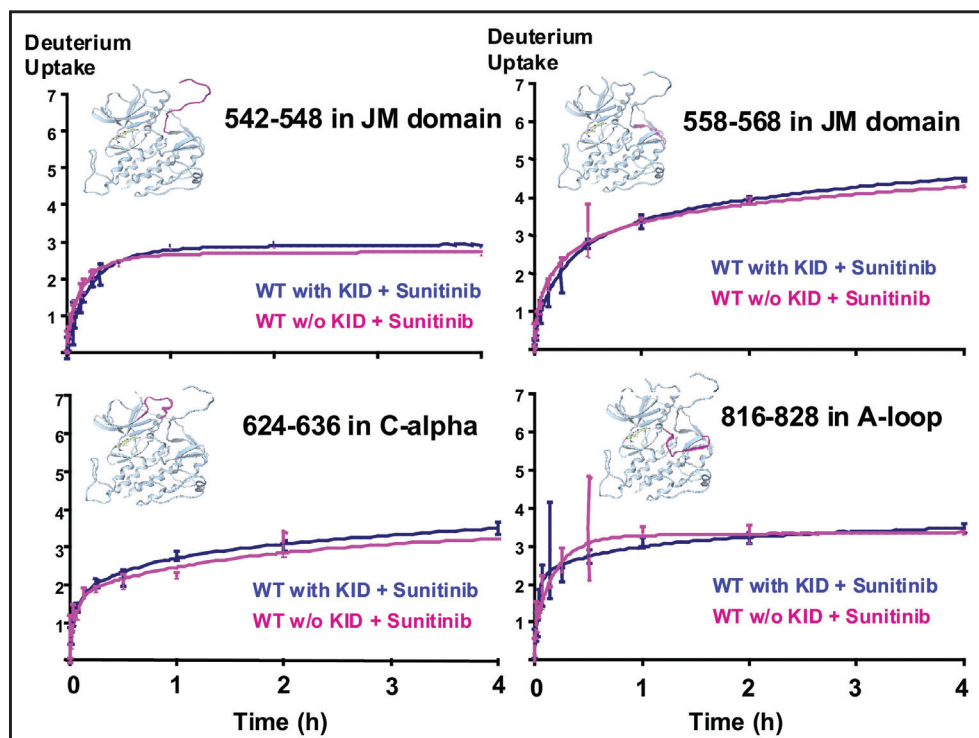

EXPERIMENTAL

Electrospray ionization mass spectra were acquired with the Magnet Lab 14.5-tesla (T) custom-built linear trap quadrupole (LTQ) FT-ICR mass spectrometer. A key result was the demonstration that the conformations (as evidenced by hydrogen/deuterium exchange profiles, see Figure) of essential structural regions of the wild-type kinase are unaffected by deletion of the kinetic insertion domain (KID), thereby validating deletion of that domain to obtain crystals suitable for X-ray diffraction analysis.

ACKNOWLEDGEMENTS

This work was supported in part by funding from Pfizer Inc., the Ludwig Trust for Cancer Research, the National Science Foundation (DMR-06-54118) and the state of Florida. Editorial assistance was provided by ACUMED (Tytherington, UK) and funded by Pfizer Inc.

REFERENCE

1. Gajiwala, K. S., *et al.*, *Proc. Natl. Acad. Sci. U.S.A.*, **106**, 1542-1547 (2009).

This work highlights some of the recent *in vivo* results published in *Magnetic Resonance Imaging* by Victor Schepkin *et al.* Magnet Lab scientists constructed and tested ^1H and ^{23}Na imaging probes for the high-resolution imaging of sodium and anatomical brain structures at 21.1 tesla (T) within the brains of large rodents. They found that there was not a field dependence in T_1 relaxation times but there was an approximately threefold increase in ^{23}Na sensitivity when compared to images acquired at 9.4 T. This publication indicates that novel MR imaging capabilities are especially advantageous for non-proton nuclei, where the gains in sensitivity are much higher than that for protons. This increase in sensitivity can be traded for either increased resolution or temporal information, both of which are particularly important for sodium imaging. Changes in sodium content and kinetics can be used to noninvasively detect cellular function and pathophysiology, due to the cells direct dependence on sodium for biologically important functions such as the regulation of membrane potentials and osmotic pressures.

• This work was published in *Magnet. Reson. Imaging*, **28**, 400-407 (2010).

In vivo Sodium and Proton MR Imaging of Large Rodents at 21.1 T

V.D. Schepkin (Magnet Lab-FSU), C.W. Levenson (FSU, College of Medicine), F.F. Calixto-Bejarano (FSU, College of Human Sciences), W.W. Brey (Magnet Lab-FSU), P.L. Gor'kov (Magnet Lab-FSU)

INTRODUCTION

High magnetic fields expand our capability to observe and investigate *in vivo* biomedical processes via magnetic resonance of protons and particularly sodium and other nuclei. Enhanced sensitivity and high resolution are especially attractive for many time-limited *in vivo* MRI studies. The ultra-high-field MR imaging at the Magnet Lab was attained utilizing multiple steps in developing the essential experimental design. The increased resonance frequency combined with the size needed to accommodate *in vivo* large rodents makes the radio frequency (RF) coil design a technically demanding project. Here it was demonstrated that volume coils can be used to achieve high-quality images at 900 MHz.

EXPERIMENTAL

The vertical 21.1 T magnet with warm bore of 105 mm was used in these experiments. The magnet is equipped with a Bruker Avance III console operated by ParaVision 5.0. For *in vivo* experiments with large rodents, Fisher rats (~ 175 g) were chosen. Rat MR imaging was achieved using the Bruker Micro-0.75 actively shielded gradient coil (ID = 57 mm). The specifically designed RF probe could accommodate a rodent having a weight of up to ~ 300 g. Physiological monitoring of the animal was continuously performed by Small Animal Monitoring and Gating System (Model 1025). No physiological triggering was used during MRI scans. Animals were anesthetized during MR scanning using 1.5 % isoflurane mixed with oxygen. Animal experiments were conducted according to the protocols approved by the FSU Animal Care and Use Committee.

RESULTS AND DISCUSSION

The rat three-dimensional proton MR images were acquired using multi-slice acquisition mode (Figure

1 A, B). The images demonstrate the capability of high-resolution imaging as can be seen by the presence of multiple small blood vessels detected as dark spots throughout the brain. Rat sodium MRI was performed with a resolution of $\sim 0.5 \times 0.5 \times 0.5$ mm (Figure 1C). Additionally, sodium T_1 relaxation times determined at 9.4 T and 21.1 T showed practically no changes for saline, as well as for *in vivo* sodium. The absence of field dependence in T_1 relaxation time can often be found in situations when the relaxation mechanism is based on the modulation of quadrupolar interactions. The high-field gain in proton sensitivity relative to 9.4 T was 2.1, which is slightly less than expected (2.25) from a linear gain with field strength. The corresponding sensitivity gains for rat sodium *in vivo* MRI were well within the expected range (~ 3.1) and close to the power of 2 relative to 9.4 T.

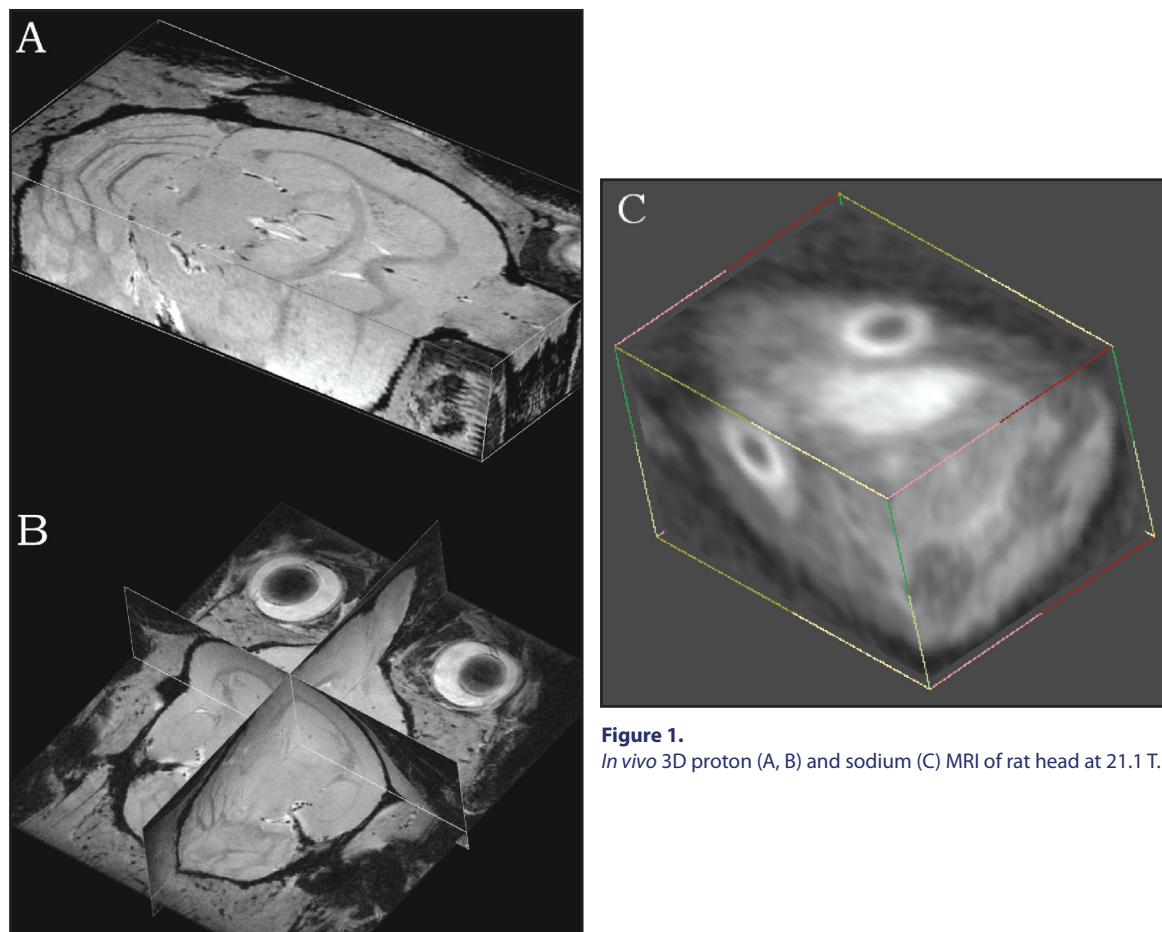

Figure 1.
In vivo 3D proton (A, B) and sodium (C) MRI of rat head at 21.1 T.

CONCLUSIONS

The high-resolution *in vivo* MR images demonstrate the advanced sensitivity and resolution that can be achieved within limited time that is a valuable advantage for many *in vivo* studies. The novel MR imaging capabilities are especially advantageous for non-proton nuclei, where the gains in sensitivity are much higher than for protons. The results were presented at the recent ISMRM Meeting¹ and published in *Magnetic Resonance Imaging*².

ACKNOWLEDGEMENTS

The *in vivo* rodent studies were supported by NIH Grant R21 CA119177.

REFERENCES

1. Schepkin, V.D., *et al.*, 17th ISMRM, Honolulu, Hawaii, #612 (2009).
2. Schepkin, V.D., *et al.*, *Magnet. Reson. Imaging*, **28**, 400-407 (2010).

This work is a continuation of magnetic resonance (MR) microimaging work being performed at the Magnet Lab on fixed tissue sections, and is the first published result using the 21.1 tesla (T) magnet to perform such measures. This is a case study comparing brain slices from a healthy subject to a 92-year-old female patient who showed steady cognitive decline with agitation and intermittent delusion (no seizures) over an 8-year period. MR microscopy on tissue slices revealed that the control tissue displayed strong cell layer delineation, with hippocampal regions. Images from the individual showed sclerotic regions with the lack hippocampal definition and displayed significantly reduced volume and cell layer compression.

• This work was published in *Neurology*, **74**, 1654 (2010).

A Novel Approach to Dementia: High Resolution ^1H MRI of the Human Hippocampus at 21.1 T

K.J. Schweitzer (Mayo Clinic FL, Neurology); P. Foroutan (Magnet Lab-FSU, Chem. and Biomed. Eng.); D.W. Dickson (Mayo Clinic FL, Neuroscience); D.F. Broderick (Mayo Clinic FL, Radiology); U. Klose (U. Hospital Tuebingen, Germany, Radiology); D. Berg (U. Tuebingen, Germany, Hertie Inst.); Z.K. Wszolek (Mayo Clinic FL, Neurology); S.C. Grant (Magnet Lab-FSU, Chem. and Biomed. Eng.)

INTRODUCTION

Demonstrating the first high-resolution MR images of human hippocampal brain sections acquired at 21.1 T (900 MHz), this case comparison presents hippocampal sections: a control (1a) versus a specimen with hippocampal sclerosis (1b)^{1,2}. The 92-year-old female patient showed steady cognitive decline with agitation and intermittent delusion (no seizures) over an 8-year period. Family history was positive for dementia. Despite marked dementia (MMSE 12/30), neurologic examination was negative.

EXPERIMENTAL

Prior to imaging, fixed postmortem human samples were washed in phosphate buffered saline (PBS) and immersed in Fluorinert (3M Corp). All MR data were acquired using a 21.1-T magnet equipped with a Bruker Avance console and Mini0.75 gradients. Utilizing a 33-mm birdcage coil, high resolution 3D ^1H Fast Low Angle Shot (FLASH) scans (TE/TR=12/50ms) were acquired over 4.3 hrs at 50- μm resolution.

RESULTS AND DISCUSSION

Control images display strong cell layer delineation, with hippocampal regions (CA 1-3) clearly visible. Sclerotic images lack hippocampal definition and display significantly reduced volume and cell layer compression.

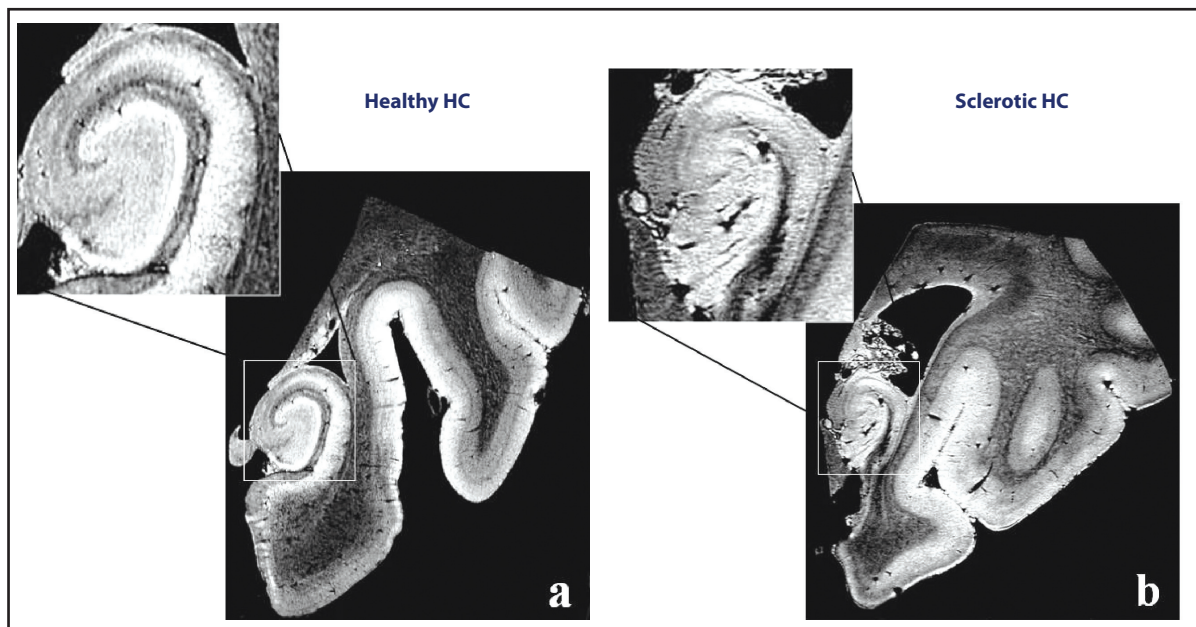

Figure 1. 3D FLASH MRI magnitude partitions of (a) a healthy hippocampal section compared to (b) hippocampal sclerosis acquired at 21.1 T.

CONCLUSIONS

This ultra-high-field strength provides sensitivity and contrast based on differences in the magnetic susceptibility between tissue types and pathologies that allows for disease determination.

ACKNOWLEDGEMENTS

This research was supported by the Magnet Lab (User Collaborations Grant Program award to SCG, NSF DMR-0084173), The Florida State University, state of Florida and the Mayo Clinic.

REFERENCES

1. Amador-Ortiz C., *et al.* *Ann Neurol*, **61**(5), 435-445 (2007).
2. Probst A., *et al.*, *Acta Neuropathol*, **114**(4), 335-345 (2007).
3. Schweitzer, K., *et al.*, *Neurology*, **74**, 1654 (2010).

The Blackband group, in a strong collaboration with scientists at Bruker Biospin and Aarhus University, recently obtained the first true single-cell image in mammalian tissue based on differences in basic contrast mechanisms. In this work, they have continued to use diffusion tensor imaging (DTI) in combination with fiber tracking to track individual nerve fibers to their cell bodies located within the rat spinal cord. Microimaging of tissue samples in combination with ultra-high-resolution DTI will provide a way to validate methodologies for tractography in magnetic resonance (MR) tissue that until now has been impractical.

• This work was published in *Neuroimage*, **46**, 1037-1040 (2009).

MR Microscopy of Nerve Fiber Structure at the Cellular Level; Validation of Tractography

J.J. Flint (UF, Neuroscience); M. Fey and Daniel Schmidig (Bruker Biospin); B. Hansen and P. Vestergaard-Poulson (Aarhus University, Denmark); S.J. Blackband (UF, Neuroscience, Magnet Lab)

INTRODUCTION

Over the last two years we have reported the utility of new microcoils developed by Bruker Instruments at high-magnetic-field strengths in order to improve the signal-to-noise ratio (SNR) in magnetic resonance microscopy (MRM). We reported the highest resolution images in mammalian (rat) brain tissue to date ($4.7 \times 4.7 \times 4.7$ microns)¹ and visualized for the first time rat neurons in brain tissue¹. In the last report we presented the first diffusion tractography at the cellular level, where individual nerve fibers were tracked in relation to the cell bodies in the tissue. However these data have an additional important function in that they provide a way to validate methodologies for tractography in MR tissue that until now has been previously impractical directly².

EXPERIMENTAL

MR data were collected as described previously¹ using a 500 μ m microcoil interfaced to a 600 MHz spectrometer in the Advanced Magnetic Resonance Imaging and Spectroscopy facility at the University of Florida. Samples were prepared from rat spinal cord. Diffusion data were collected using a 21 direction encoding procedure, but then reconstructed using either 21 or only 6 directions from that data set.

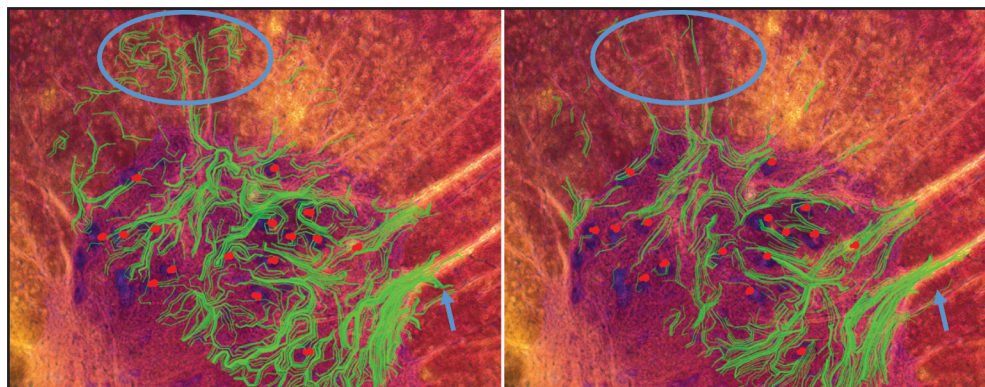

Figure 1. Fiber track maps (green lines) overlying cell positions (red dots) generated using just 6 (left) or 21 directions (right). Note the more robust fitting in the 21-direction data set, for example within the blue circle and at the blue arrow.

CONCLUSIONS

These data illustrate how MRM tractography at the cellular level can validate MR techniques through direct correlative histology. Although the 21 direction methodology appears more robust, the data takes longer to collect, providing a way to evaluate the important trade-off between imaging time and accuracy. This data, in the future, will provide a way of evaluating different imaging techniques and analysis.

ACKNOWLEDGEMENTS

Funding provided by the NSF through the National High Magnetic Field Laboratory, the McKnight Brain Institute, the KTI (Switzerland, CTI project 6364.1 KTS-NM), the Danish National Research Foundation (95093538- 2458, project 100297), the Denmark-America Foundation, Dagmar Marshall's Foundation, Julie von Müllen's Foundation and the Oticon Foundation.

REFERENCES

1. Flint, J.J., *et al.*, *Neuroimage*, **46**, 1037-1040 (2009).
2. Hubbard, P.L., Parker, G.J.M., Validation of Tractography. In: *Diffusion MRI: From Quantitative Measurement to In-vivo Neuroanatomy*. Johansen-Berg H., Behrens, T.E.J., (Eds.). Academic Press (2009)

Chapter 3: User Programs

The strength of the user programs is built around the synergies of the highest field magnets, unique instrumentation, and exceptional support from highly qualified faculty and staff. In this chapter, each of the laboratory's user facilities—DC Field, Pulsed Field, High B/T, NMR, AMRIS, EMR, ICR; and Geochemistry which is affiliated—presents information about its research capabilities, developments, plans, productivity, and efforts to build the user community during 2009.

Efforts to standardize statistics and operations across all facilities continued in 2009. A standard definition for *new user* was agreed upon: A new user is defined as a *new user principal investigator*, who may be a completely new user of the Magnet Lab facility or one who is serving for the first time as a PI on his/her own research project. This "new user" generally leads a group of researchers, some of whom may also be new to the Magnet Lab, but are not included in the count. The Magnet Lab reports 118 new users this year: 23 in the DC Field Facility; 28 in Pulsed Field Facility; 11 in NMR; 15 in AMRIS; 20 in EMR; and 21 in ICR.

In the fall, the first-generation magnet time request and users management system that had been used by DC Field and NMR since 2003 was redesigned and launched on January 4, 2010, to support all seven programs. The **Unified User Portal System** is intended to be an easy to access single point of entry for all of the Magnet Lab's user programs. In addition, it:

- standardizes policies across all facilities,
- institutes common practices in the content, review, and management of all proposals,
- implements external review for all proposals,
- supports user and facility needs for responsiveness and flexibility with regard to system offerings, samples (and possible safety-related issues), scheduling, and
- ensures transparency of the magnet time assignment process.

The Web site, <https://users.magnet.fsu.edu/>, provides complete details on the portal, as well as user policies for proposal review and magnet time assignment; appeals; and confidentiality and ethics.

Detailed user statistics for each facility are presented in **Appendix A**; a few lab-wide user statistics responding to some frequently asked questions are presented in **Tables 1 and 2**.

Table 1. Magnet Lab User Profile¹

	Total	Women	Minority	NHMFL-Affiliated Users ²	Local Users ²	University Users U.S. ^{3,5}	Industry Users U.S. ⁵	National Lab Users U.S. ^{4,5}	Non-U.S. Users ⁵
Senior Investigators	670	72	28	149	98	319	29	144	178
Postdocs	162	29	11	52	23	74	0	49	39
Students	346	94	31	89	77	252	0	25	69
Total Users	1178	195	70	290	198	645	29	218	286

¹ The laboratory reports seven user facilities (DC Field, Pulsed Field, High B/T, NMR, AMRIS, ICR, EMR) and the Geochemistry Facility, which is affiliated. A user is an individual or a member of a research group that is allocated magnet time. The user does not have to be "on site" for the experiment. Consequently, a researcher who sends samples for analysis; a scientist who uses new lab technologies to conduct experiments remotely; or a PI who sends students to the Magnet Lab, are all considered users.

² NHMFL-Affiliated users are defined as anyone in the lab's personnel system [i.e. on Web site/directory], even if they travel to another site.

Local users are defined as any non-NHMFL-affiliated researchers originating at any of the institutions in proximity to the MagLab sites (i.e. researchers at FSU, UF, FAMU, or LANL), even if they travel to another site.

The sum of NHMFL-Affiliated and Local users equals what was formerly referred to as "Internal Investigators".

³ In addition to external users, all users with primary affiliations at FSU, UF, or FAMU are reported in this category, even if they are also NHMFL associates.

⁴ In addition to external users, users with primary affiliations at NHMFL/LANL are reported in this category.

⁵ Four columns of users (university, industry, national lab, non-U.S.) will equal the Total Number of Users.

Table 2. Magnet Lab Facility Usage Profile

	Number of Magnet Days ¹ Allocated	Condensed Matter Physics	Chemistry, Geochem.	Engineering	Magnets, Materials, Testing, Instruments	Biology, Biochem., Biophys.
NHMFL-Affiliated ²	2725	687	947	170	99	822
Local ²	1116	276	320	116	11	393
U.S. University	2281	1192	548	56	9	476
U.S. Govt. Lab.	446	212	75	0	5	154
U.S. Industry	59	8	15	17	8	11
Non-U.S.	1061	727	143	32	51	108
Test, Calibration, Set-up, Maintenance ³	1568	31	376	200	776	185
Idle	1187	NA	NA	NA	NA	NA
Total	10443	3133	2424	591	959	2149

¹ User Units are defined as magnet days for four types of magnets. [This definition is used for Magnet Lab reporting to NSF for Government Performance & Reporting Act (GPRA) purposes]. One magnet day is 7 hours in a water cooled resistive or hybrid magnet in Tallahassee. One magnet day is 12 hours in any pulsed magnet in Los Alamos and 24 hours in superconducting magnets in Tallahassee, Los Alamos, and the High B/T system in Gainesville.

Magnet days for AMRIS instruments in Gainesville: Verticals (500, 600s, & 750 MHz), 1 magnet day = 24 hours (7 days/week); Horizontals (4.7, 11.1, and 3T), 1 magnet day = 8 hours (5 days/week).

² Use by NHMFL-Affiliated and Local users as defined in Table 1. footnote 2.

³ In 2007 and prior years, not all facilities captured this information. Beginning in 2008, all groups collected this data so it is now included in the summary table.

User Facility: DC Field

2009 statistics on DC Field Facility users, projects, and magnet usage are presented in Appendix A.

The DC magnetic field facility at the NHMFL headquarters in Tallahassee continues to provide the user community with the highest and quietest slowly varying magnetic fields in the world. The magnets are coupled with state-of-the-art instrumentation resulting in a suite of powerful measurement environments for research. Expert experimental staff members provide users with scientific and technical support while using the DC facilities.

Florida-Bitter and Hybrid Magnets		
Field (T), Bore (mm)	Power (MW)	Supported Research
45 T, 32 mm, (25 ppm/mm)	31.0	Magneto-optics – ultra-violet through far infrared; Magnetization; Specific heat; Transport – DC to microwaves; Magnetostriction; High Pressure; Temperatures from 30 mK to 1500 K; Dependence of optical and transport properties on field, orientation, etc.; Materials processing; Wire, cable, and coil testing.
36 T, 32 mm	19.0	
35 T, 32 mm	19.2	
31 T, 32 mm to 50 mm ¹	18.4	
29 T, 32 mm (~5 ppm/mm) ²	18.3	
20 T, 195 mm	20.0	
25 T, 52 mm, (1 ppm/mm) ²	18.6	
Superconducting Magnets		
Field (T), Bore (mm)	Sample Temperature	Supported Research
18/20 T, 52 mm	20 mK – 2 K	Magneto-optics – ultra-violet through far infrared, Magnetization, Specific heat, Transport – DC to microwaves, Magnetostriction; High pressure, Temperatures from 20 mK to 300 K, Dependence of optical and transport properties on field, orientation, etc. Low to medium resolution NMR, EMR, and sub/millimeter wave spectroscopy.
18/20 T, 52 mm	0.3 K – 300 K	
17.5 T, 47mm ³	4 K – 300 K	
17.5 T, 34 mm, (50 ppm/cm) ²	0.3 K – 300 K	

1 A coil for modulating the magnetic field and a coil for superimposing a gradient on the center portion of the main field are wound on 32 mm bore tubes.

2 Higher homogeneity magnet for magnetic resonance measurements.

3 Magnet system for optical measurements.

Facility Developments

In 2009 the DC program made the first significant changes in the way that the facility operates in more than 10 years. In prior years users in the resistive and hybrid magnets were assigned time in one of two 7-hour shifts over a 4½ day week providing a total available magnet time of 31½ hours. If users had a problem with samples or cryogenics it was often difficult or impossible to recover this lost time. *Starting in March 2009, the magnet shifts were extended by 2½ hours each providing users with up to 10 hours of magnet time each day or 41½ hours available per week.* Of course if this 33% additional time were used our electricity bill would increase by 33%, which our electricity budget can not support. To avoid this, all users have been given an energy budget that is calculated based on the prior 31½ hours of magnet time. Thus each group can decide how to use this energy in a way that best meets their own scientific agenda.

We have called this expanded schedule and energy budget policy “Flexitime” and the feedback has been overwhelmingly positive. We have found that when users data and experimental performance were not up to their expectations, they generally shut down the experiment with the expectation that they would be able to improve their sample or measurement technique and have the flexibility to make up the lost time later. Previously when time was the limiting factor, many MWHrs (megawatt hours) were expended on sub-optimal experiments. Now with their energy budget being the limiting factor, experiments are run more efficiently with no decrease in scientific results or throughput.

The DC Field Instrumentation has seen significant changes this year even in the face of budget constraints. We continue our ongoing projects to improve base noise levels in the experimental areas, improve magnetic field quality, and provide more varied and accessible sample environments. Incremental improvements in data acquisition, thermometry, and instrumentation were achieved throughout the facility.

The millikelvin lab was furnished with RF screening over the window areas. This has reduced the noise level by about 20 db. This significant reduction in noise level has improved measurements by NMR, Tunnel Diode Oscillator, and heat capacity by quantifiable amounts. The project was executed by **Dr. Ju-Hyun Park** and measurements of the effectiveness are documented on the DC Field Instrumentation WIKI, http://opsxserve.magnet.fsu.edu/groups/operations/wiki/4aebb/RF_Reduction_in_milliKelvin_Building.html, and in a published NHMFL Research Report. In addition the flooring of the millikelvin lab, which was delaminating, was replaced with a more robust and durable flooring. These improvements, though making the facility unavailable for a few weeks, have improved the quality and effectiveness of the facility.

The experimental cryogenic systems for the resistive DC magnets received upgrades as well. A long planned update to a new top loading helium-3 and Variable Temperature Insert combination now provides a larger temperature range, much longer hold time, better temperature stability, and more sample space than the older systems it replaces. This top loading system will now provide temperature stability in the important range above 30 K, which was difficult to stabilize in the old systems. These new systems have multiple probes with a flexible access and come configured for either multiple samples or sample rotation. Users have been very pleased both with the quality of their data when using these systems and their convenience. The ability to quickly change samples has also made more efficient use of magnet time.

In 2009 the first measurements of Raman spectra at ultra high magnetic fields were done at the NHMFL. This new capability has been developed by Dr. **Dmitry Smirnov**; though it is still in the development stages, initial results have been very exciting. We expect that as this system is developed and the bugs are worked out it will see heavy demand by the users.

The infrastructure for the DC Field program received significant upgrades during 2009. Since 2004 plans have been underway to upgrade our four power supplies from 10 MW to 16 MW and improve their stability and reliability while decreasing their noise floor. In 2006, the first stage of this upgrade was begun. This year we completed the final phase of this upgrade in two of the four power supplies with the installation of filter inductors and transformers. Ripple reduction has been significant, especially in the 720 Hz region, which had created unwanted heating effects. An ongoing program for further improvements to the power supplies is in place and moving forward now that the final configuration for the power supplies is in place. Because of these upgrades we ran half of our normal number of users for the two months that the installation was being done. We expect that the other two power supplies will be upgraded in 2010.

In addition to the power supplies, major upgrades to the components of the water-cooling system for the magnets have been specified and ordered. These components are required for the new generation of magnets that are currently being designed, such as the Optical Split Bore magnet.

The helium gas recovery system had significant upgrades to improve the capacity and reduce the contamination in the returned helium. The second of our aging piston liquefiers was sent for a major overhaul after 15 years of continuous service and hard use. We expect it back and producing at peak capacity by the end of March 2010. Because of this shutdown, our 45 T hybrid magnet was down during the last two months of 2009 and is expected to be running again in May 2010.

A new turbine helium liquefier with greatly increased capacity over the piston liquefiers was specified and ordered. The integration of this much larger system into the lab infrastructure will ensure the reliability of the 45 T hybrid operations, the operation of the new Series Connected Hybrid, and increased cryogenic demands of the lab. The new system is scheduled to be on-line and producing liquid helium by the end of 2011.

Science Productivity

To date, 73 peer reviewed publications, 91 presentations, and 5 Ph.D. and 2 Master theses have been reported for the DC Field Facility for 2009.

Research on graphene at the MagLab has blossomed from an exciting new development with just a few groups involved to a major effort with 17 different user groups doing research involving graphene in 2009. Among these 17 were 6 user groups that were new to the NHMFL.

- An exciting example of this work was the effort of the group led by **Phillip Kim** at Columbia and **Zhigang Jiang** at Georgia Tech. **Figure 1** shows the formation of an 8-fold degenerate Landau level in bi-layer graphene at various magnetic fields. As the magnetic field is increased, new plateaus emerge; as successive symmetries are broken and at fields higher than 25 T, the degeneracy is completely lifted. This is in stark contrast to the quantum Hall effect in mono-layer graphene which is itself quite different from the quantum Hall effect in conventional 2D electron systems. Readers will find a broad variety of work on graphene in the pages of this annual report. We expect that this field of research will continue to yield rich results for years to come.

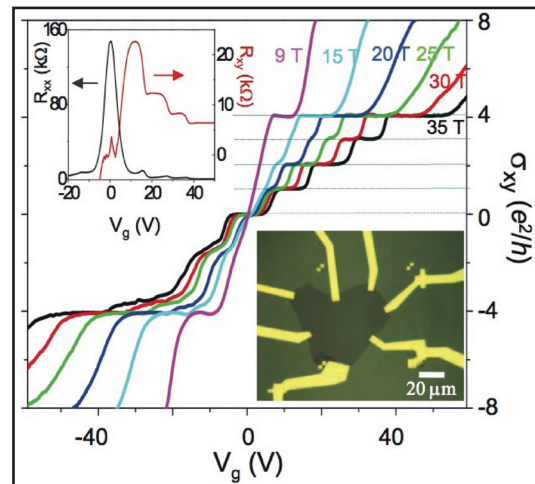

Figure 1.

- The quantum Hall effect in GaAs is a mature field that has been studied for many years. However, QHE research at the MagLab continues to yield exciting new results. In the work by the group led by Prof. **Dan Tsui** at Princeton and Dr. **Lloyd Engel** at the NHMFL with samples from **Lauren Pfeiffer** and **Ken West** at Bell Labs the nature of the Wigner crystal state in a 2D system at high fields and low temperatures is explored. **Figure 2 (a)** shows the microwave spectra for Landau filling $\nu=1$ while **(b)** shows the spectra for $\nu=1/3$. The well developed peak for the $\nu=1$ Landau level is the signature of the integer quantum Hall effect Wigner crystal state. The narrow resonance shown at the $\nu=1/3$ state is clear evidence for a Wigner crystal state made up of quasiparticles with a charge of $e/3$. This work, which was performed in high fields at low temperatures (55 mK) with the field rotated (to suppress skyrmion effects), is an example of cutting edge research that could only be performed with MagLab facilities and expertise.

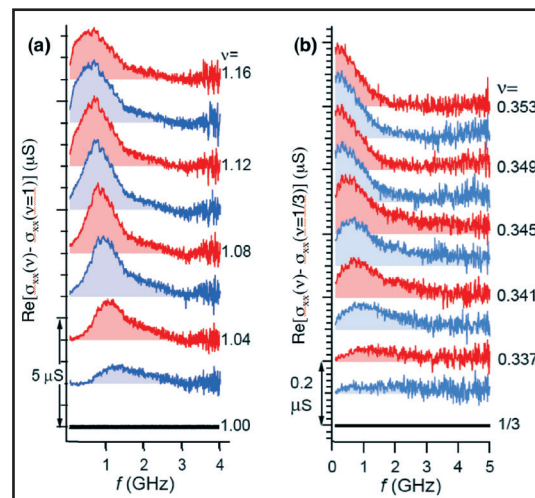

Figure 2.

In addition to ground-breaking work on semiconductors, the NHMFL has continued to provide support to users making significant advances in areas that are traditional strengths for the MagLab, such as basic research on conventional, High TC and unconventional superconductors, and wide range of other experiments in a variety of fields.

Progress on STEM and Building the User Community

Twenty-three new user principal investigators and their groups were attracted to the DC facility (up from 17 in 2008) from institutions as diverse as Tohoku University, Kanazawa University in Japan, University of Stuttgart, University Paris Diderot, University of Geneva, ETH Zurich, MIT, University of Pittsburgh, Arizona State, SUNY Buffalo, University of Texas Austin, and Brookhaven National Laboratory. Five of these new user groups were led by former students or postdocs who had done research at the MagLab and are now PIs on their own. The fact that these young researchers choose to use the MagLab as part of their research plans affirms its effectiveness and value.

The Open Doors laboratory continues to collaborate with external scientists from underrepresented groups and provide them with a 16T Quantum Design PPMS system that provides fully automated measurements. These experiments can then be moved into higher field systems if needed. Professor **James Dickerson** of Vanderbilt University, a former chair of the APS Committee on Minorities, spent 6 months at the NHMFL as a visiting scientist working with this system and with Dr. **Stephen McGill** and the optics program.

User Facility: Pulsed Field Facility

2009 statistics on Pulsed Field Facility users, projects, and magnet usage are presented in Appendix A.

The Pulsed Field Facility (PFF) and the Los Alamos branch of the NHMFL are located in Los Alamos, New Mexico, at the Los Alamos National Laboratory (LANL). The pulsed field users program is designed to provide researchers with a balance of the highest research magnetic fields and robust scientific diagnostics specifically designed to operate in pulsed magnets. The connection with the DC Field Facility is strong and complementary in expertise. Achieving the highest magnetic fields possible is not what this facility is focused on. Instead, we strive to create the very best high-field research environment possible and to provide users with assistance from some of the world's leading experts in science conducted in pulsed magnets. All of the user support scientists are active researchers and collaborate with multiple users per year. A fully multiplexed and computer controlled, 6-position 1.6 mega-Joule (32 mF @ 10 kV) capacitor bank system is at the heart of the pulsed field activities. Some 4000 shots per year are fired for the users program, which accommodates approximately 100 different user groups.

Capacitor-Bank-Driven Magnets at the Magnet Lab at Los Alamos	
Field (T), Duration, Bore (mm)	Supported Research
50 T Mid-Pulse, 400 msec, 15 mm (Cell #1) 65 T Short Pulse, 25 msec, 15 mm (Cell #2) 65 T Short Pulse, 25 msec, 15 mm (Cell #3) 65 T Short Pulse, 25 msec, 15 mm (Cell #4) Test Cell 100 kA peak current (Cell #6) 60 T Long Pulse Magnet, ~3 sec, 32 mm 85T Multi-Shot, 10 msec, 15 mm Single Turn (to 240 T so far), 0.06 msec, 10 mm	Magneto-optics (IR through UV), magnetization, and magneto-transport from 350 mK to 300 K. Pressure from 10 kbar typical, up to 100 kbar. GHz conductivity, MHz conductivity, Pulse Echo Ultra-sound spectroscopy.
Superconducting Magnets	
Field (T), Duration, Bore (mm)	Supported Research
18/20 T magnet, 52 mm 15/17 T magnet 52 mm 12/15 T magnet, 52 mm 13/15 T magnet 52 mm 14 T-PPMS magnet	Same as pulsed fields, plus thermal-expansion, specific heat, and 20 mK to 600 K temperatures. Heat capacity, THz Resistivity, Magnetometry

Facility Developments

In 2009 the PFF has been focused on completion of the first set of user experiments in the 85T multi shot magnet system. The NHMFL-PFF had a rather extensive review of the proposal with scientists from all three sites participating in the review process. 6 proposals were selected for magnet time with 4 backup proposals also selected. In June 2009, after completing the first 2 scheduled experiments and providing 110 85T pulses, the insert failed. Insert #2 was completed in September 2009 and allowed us to complete the first set of 6 user experiments and 2 backup experiments with a total of 62 full field (85T) pulses to date. A third 85T insert is in production. The second round of requests for proposals will go out in spring 2010 for magnet time scheduled for summer 2010.

The new 16 kV, 4 MJ user capacitor bank safety review was completed in 2009 and is currently in the final commissioning stage. Magnet designs are being worked on to take full advantage of this new capability.

Facility Plans

A plan to have replacement coils for the 60T long pulse and 100T Multi shots magnet is in place and procurement of the conductor and contractor services will begin in 2010.

Design and development of the next generation pulsed insert for the 100T MS system is underway with a projection of delivery for late 2010.

Science Productivity

To date, 52 peer reviewed publications, 38 presentations, and 2 theses have been reported for the PFF for 2009. Two significant achievements are very briefly presented here.

- Quantum oscillations were measured on successively lower dopings of the high T_c YBCO_{6+x} up to 85T, resulting in a publication to appear in the *Proceedings of the National Academy of Sciences* (**E. Sebastian, G. G. Lonzarich** (Cambridge U), **N. Harrison, C.H. Mielke, M. Altarawneh** (NHMFL Los Alamos), **R. Liang, D. Bonn, W. Hardy** (UBC) (**Figure 3**).
- The group of **P.J.W. Moll, J. Karpinski, B. Batlogg** (Solid State Physics Lab, ETH Zurich, Switzerland) and **F. F. Balakirev** (LANL) investigated the anisotropy of magneto-transport in FIB-carved LnFeAs(O,F) (Ln= La, Nd, Pr, Sm) single crystal nanostructures. The so called "1111" materials (LnFeAs(O,F)) grow as thin (< 10 μm) platelets, thereby demanding novel techniques of sample preparation on μm scales. The group developed a technique involving a Focused Ion Beam (FIB) to carve small sheets out of single crystals and contact them with sub- μm precision, allowing the simultaneous measurement of in-plane and out of plane resistivity in the same piece of single crystal (**Figure 4b**). The resistance bars for c-axis 4-point measurements are 5 μm long and have a typical cross section of 1 μm^2 . Therefore they show a high absolute resistance (>110 Ω) and are especially suited for pulsed experiments. All experiments were performed in 65-T short pulse magnets at NHMFL-PFF.

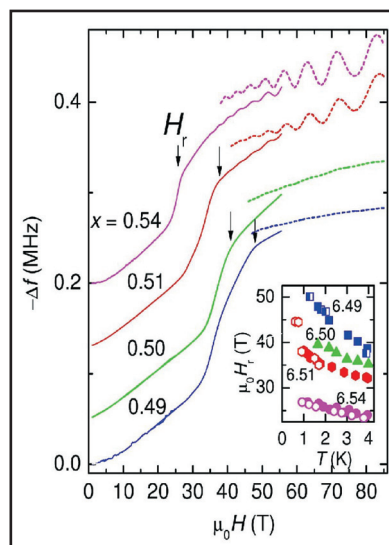

Figure 3. With increasing irreversibility fields, progressively higher fields are required to observe quantum oscillations in lower dopings. From quantum oscillations measured in the lowest dopings of YBCO_{6+x} E. Sebastian *et al.* uncover a striking collapse of the Fermi velocity, yielding clues about the evolution of unconventional Cooper pairs from the parent Mott insulator.

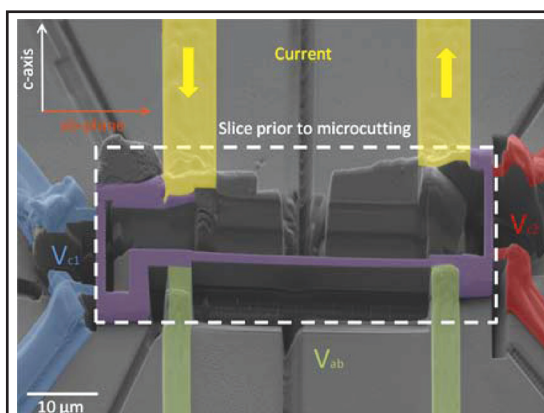
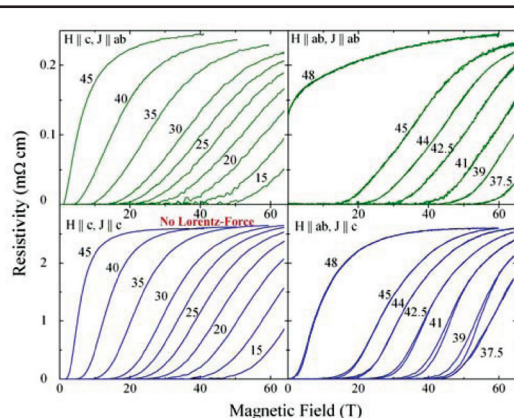

Figure 4.

(a) Three contiguous 4-point resistance bars probe resistivity along two in equivalent orientations of one SmFeAs(O,F) single crystals. The sample was produced by FIB ion milling. (b) Magnetoresistance of SmFeAs(O,F) for all field and current configurations. The resistivity is mainly determined by the field orientation, and almost independent of the current orientation.



Progress on STEM and Building the User Community

The NHMFL-PFF provided magnet time for 108 distinct projects in 2009 with 71 different principal investigators. Of the total number of PIs, 28 were new users.

The REU program from the NSF has given the PFF an excellent opportunity to extend the impact of the facility onto underrepresented groups in the scientific community, particularly with the student community. Several students from underrepresented groups were involved in the program this year providing mutual benefits to the students and the PFF mentors.

Travel support is available and may be granted to new users. This resource is helping to expanding the user base with new PIs and is particularly important considering the relatively remote location of the PFF in Los Alamos.

The staff members of the PFF continue to make considerable efforts in the area of outreach. In 2009 a summer school was organized by Albert Migliori, chair of the Magnet Lab Science Council. Held at the DC facility in Tallahassee, the school helped new users and students understand the complexity of conducting experiments in all of the NHMFL facilities via lectures and hands-on experience. Many scientists from the NHMFL-PFF gave their time to teach at this event, which will be continued in 2010.

User Facility: High B/T Facility

2009 statistics on the High B/T Facility users, projects, and magnet usage are presented in Appendix A.

The High B/T facility is open to all qualified users who need to conduct experiments in high magnetic fields (currently up to 16 T) and to very low temperatures (down to 0.3 mK) simultaneously. Specialized facilities and resources are available for experimentalists and are housed in two buildings (a) the UF Microkelvin laboratory, and (b) neighboring Williamson Hall. Two experimental stations are available in the Microkelvin Laboratory: (i) a PrNi₅ nuclear refrigerator in Bay 3 with fields up to 16 T (with good homogeneity sufficient for condensed matter NMR experiments) and capable of high cooling rates down to 0.4 mK, and (ii) a Cu nuclear refrigerator in Bay 2 for temperatures down to 0.1 mK and for fields to 10T. In Williamson Hall a fast turn-around facility is available for pre-testing samples and experimental cells to 10 T and 10 mK. The use of bay 2 is limited by available staff. The facilities are designed with high cooling powers and *tempest* quality electromagnetic shielding, enabling experiments that require sensitive electrical readings or RF input excitations (such as NMR).

Facility Developments

A major upgrade is planned for 2010 with the addition of a 20-21 T magnet currently being completed by Cryomagnetics Inc. The new magnet will further advance the state-of-the art in High B/T capabilities with the UF facility exceeding capabilities elsewhere. The facilities for Bay 3 and Bay 2 typically run 2 to 3 months after a 1-2 month design and testing phase. Users are asked to contact local staff about the design of experiments well in advance as there is typically a 10-month queue for experimental time for Bay 3.

Science Productivity

The High B/T Facility reported 11 peer reviewed publications for 2009, including three significant publications, and there were 7 research reports from a total of 5 independent experiments in 2009. Two examples of exceptional science include:

- Interplay of Frustration and Magnetic Field for the 2D Quantum Antiferromagnet Cu(tn)Cl₂
A. Orendáčová, E. Čížmár, L. Sedláková, J. Hanko, M. Kajňaková, M. Orendáč, V. Zeleňák, A. Feher (P. J. Šafárik University, Košice, Slovakia); **J. S. Xia, L. Yin, D. M. Pajerowski, M. W. Meisel** (UF Physics and NHMFL); **S. Zvyagin, J. Wosnitza** (Hochfeld-Magnetlabor Dresden, Germany).
 Publication: "Interplay of frustration and magnetic field in the two-dimensional quantum antiferromagnet Cu(tn)Cl₂", Phys. Rev. B **80**, 144418 (2009).

Measurements of the isothermal ac susceptibility (**Figure 5**) show the signature expected for field induced transitions from a vortex-antivortex bound state to a fully polarized state at higher magnetic field. Specifically, the "shoulder" signature observed above 6 T is associated with the saturation magnetic field B_{sat} ($T \rightarrow 0$) = 6.6 T. These data resolved a crucial question about the boundary of the magnetic phase diagram (**Figure 6**), and the magnetic phase diagram constructed from an analysis of the data is remarkably consistent with the one predicted for a Berezinskii-Kosterlitz-Thouless (BKT) phase on a square lattice without a frustrating interaction, except that B_{sat} is shifted to values lower than expected.

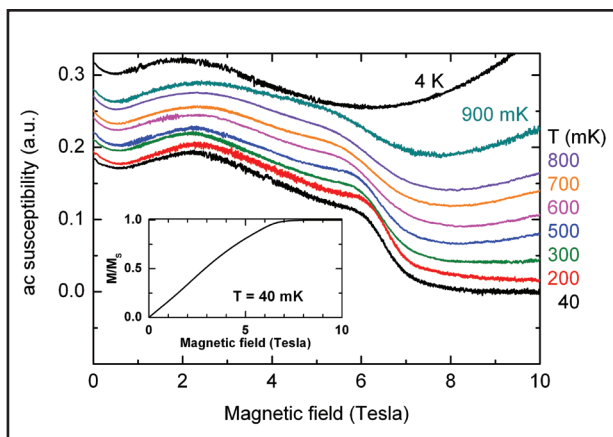

Figure 5.
Low temperature AC susceptibility of Cu(tn)Cl₂

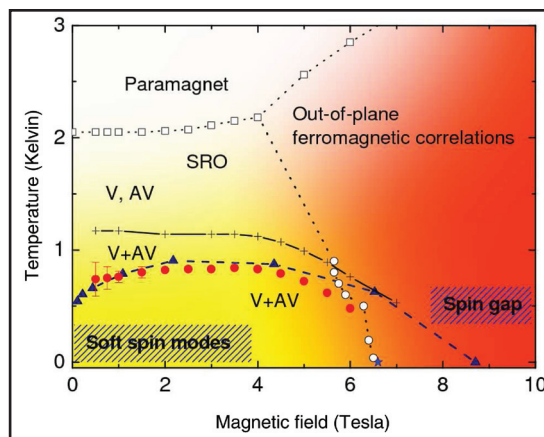

Figure 6.
Phase diagram interpreted from the data.

- Nanodroplet Formation in Solid Solutions of Very Dilute ^3He in Solid ^4He .

S.S. Kim, C. Huan, L. Yin, J.S. Xia, N.S. Sullivan (UF, Physics); **D. Candela** (Physics, Univ. of Massachusetts)

Publication: S. S. Kim, C. Huan, L. Yin, J. S. Xia, D. Candela and N. S. Sullivan, "NMR Studies of ^3He Impurities in ^4He in the Proposed Supersolid Phase," *J. Low Temp. Phys.* **158**, 584-589 (2010).

NMR studies have been carried out to probe the local dynamics of very dilute ^3He impurities in solid ^4He and to test for changes in the local motions near the temperatures for which non-classical rotational inertia fractions have been observed. It is thought that these fractions point to macroscopic supersolid flow. Addition of ^3He impurities has been shown to suppress the so-called "supersolid" effects and our previous experiments confirmed that the ^3He impurities (at least for concentrations down to 250 ppm) diffuse by quantum mechanical tunneling. The NMR experiments are designed to observe the motions down to approximately 10 ppm and to test whether ^3He atoms become localized at dislocations or other defect sites in the "supersolid" region.

The amplitudes of the NMR signal (as measured by the amplitude of a solid echo) are shown in **Figure 7**. Above 120 mK a typical Curie law (T^{-1}) dependence is observed as expected for the paramagnetic behavior of the nuclear spins. Below 120 mK (at a temperature that varies with ^3He concentration) one observes a sharp change with a flat temperature independent behavior at low temperatures. This temperature independence is understood in terms of the formation of nanodroplets of liquid ^3He typically 2-6 μm . Hysteresis is observed on cycling through the phase separation temperature. Measurements of the nuclear relaxation times have been carried out also and large changes are seen at the phase separation temperatures. No detectable signature of a supersolid phase has been seen in the relaxation measurements suggesting the phenomena is localized (possible at grain boundaries) rather than a global property.

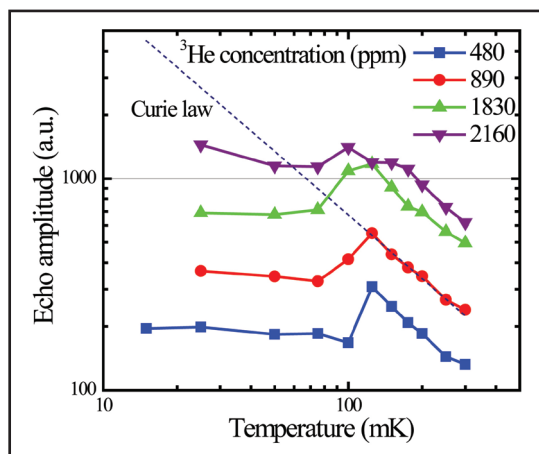

Figure 7. ^3He in solid ^4He . Temperature dependence of NMR echo amplitude showing phase separation and formation of ^3He nanoclusters below 150mK.

Progress on STEM and Building the User Community

No totally new international user groups (that is, lead by new user principal investigators) were added to the High B/T Facility users list in 2009. New users were included, however, as part of expanded experimental activities in association with previous user/Pis. The additions include **J. Wosnitza** (Hochfeld-Magnetlabor Dresden, Germany) with PI **Mark Meisel**, and **M. W. M. Chan** (The Pennsylvania State University) with PI **J. S. Xia**. A new group from Nanking University has expressed interest in collaborations on a new experiment with M. Meisel.

The Microkelvin Laboratory and its faculty members hosted several visits from groups of high school students and their teachers for guided tours of the High B/T Facility in 2009. In addition UF-NHMFL faculty members hosted three REU students for summer research programs, including two from the Tallahassee REU program.

User Facility: NMR Spectroscopy and Imaging in Tallahassee

2009 statistics on NMR Facility users, projects, and magnet usage are presented in Appendix A.

The NHMFL NMR program in Tallahassee has a mission to develop technology, methodology, and applications at the highest magnetic fields through both in-house and external user activities. This is a very broad mission in solution and solid-state NMR spectroscopy as well as magnetic resonance imaging and diffusion measurements. The facility is staffed with research faculty, engineers, and technicians spanning these disciplines who are available to facilitate user activities on a wide range of unique instrumentation and to develop novel experiments and new instrumentation.

NMR and MRI Systems at the Magnet Lab in Tallahassee

NMR Frequency	Field (T), Bore (mm)	Homogeneity	Measurements
1.7 GHz	40, 32	10 ppm	Solid State NMR
1066 MHz	25, 52	1 ppm	Solid State/Solution NMR
900 MHz	21.1, 105	1 ppb	Solid State NMR, MRI
830 MHz	19.6, 31	100 ppb	Solid State NMR
800 MHz	18.7, 52	1 ppb	Solution NMR, Cryoprobe
720 MHz	16.9, 52	1 ppb	Solution NMR
600 MHz	14, 89	1 ppb	MRI and Solid State NMR
600 MHz	14, 89	1 ppb	Solid State NMR
600 MHz	14, 52	1 ppb	Solution NMR
500 MHz	11.75, 89	1 ppb	Solid State NMR
500 MHz	11.75, 52	1 ppb	Solution NMR, Cryoprobe
400 MHz	9.4, 89	1 ppb	Solid State NMR
300 MHz	7, 52	1 ppb	Developmental NMR
300 MHz	7, 89	1 ppb	Solid State NMR

Facility Developments and Plans

The flagship instrument of the NMR program is the NHMFL's ultra-wide bore 900 MHz magnet with a Bruker Avance III console that is being used for imaging and solid-state spectroscopy. While this instrument has demonstrated solution NMR capabilities the solid state NMR and MRI activities take better advantage of the 105 mm room temperature bore. A broad spectrum of MAS and aligned sample double resonance probes are now available on the wide bore 400, two wide bore 600s, and the 900. While we have had commercial MAS triple resonance probes for these instruments, the first high performance NHMFL MAS triple resonance probe has recently been tested on one of the 600 MHz instruments. A suite of MAS and aligned sample triple resonance probes at 400, 600 and 900 will be developed during 2010. These probes are all enhanced low-electric field probes that minimize sample heating from the RF irradiation—a feature that is critically important for biological solid state NMR spectroscopy. Both commercial imaging probes and unique double resonance NHMFL-developed probes for MRI have been demonstrated with excellent specifications for the vertical bore 900 and are attracting users to the NHMFL.

Compact gradient coils that will be delivered in the second quarter of 2010 will permit the facility to take full advantage of the 105 mm bore. The animal facility has recently been upgraded and is located conveniently close to the 900 MHz instrument. Unique high sensitivity probes for the characterization of quadrupole nuclei continue to attract an international user community for the 31 mm bore, 830 MHz spectrometer. With the strong support of the NMR Users Advisory Committee, a high priority for the NMR Program is the upgrading of the spectrometer consoles for the entire suite of instruments.

Science Productivity

To date, the NMR program reports 33 peer reviewed publications, including 7 in *Physical Review Letters*, *Journal of the American Chemical Society*, and *Angewandte Chemie International Edition*, and one each in *Cell*, *Proceedings of the National Academy of Sciences, USA*, *Nature Structural & Molecular Biology*; and *Journal of Biological Chemistry*. We had no dissertations for 2009, but we do have 58 research reports spanning a broad range of disciplines from Biology and Biophysics to Chemistry and Engineering with 172 users, including 38 women and 9 minorities.

• Dr. **Chunqi Qian** and **Peter Gor'kov** at the Magnet Lab teamed up with Prof. **Sam Grant** of Chemical and Bio-medical Engineering at FSU and the Magnet Lab to construct an efficient double-resonant ^1H - ^{23}Na coil (**Figure 8**) for neuroimaging in large rodents. To maintain azimuthal symmetry of ^1H B_1 fields, we used a sliding metal ring to vary the overlapping capacitance between the ring and the legs. **Figure 9** shows image comparison for different samples in single-resonance ^1H coils. To achieve impedance matching for both samples, a conventional fixed-element coil of the same size cannot have more than 8 legs. The tuning range of a sliding-ring coil actually increases with the higher number of legs; it also yields more homogeneous images (**Figures 9 and 10**). We expect this user facility instrumentation to enhance low- γ imaging capability at the NHMFL and exploit the advantages of high field spectrometers for the MRI community. This work was highlighted by the Young Investigator Award in the 9th International Conference in Magnetic Resonance Microscopy in 2009.

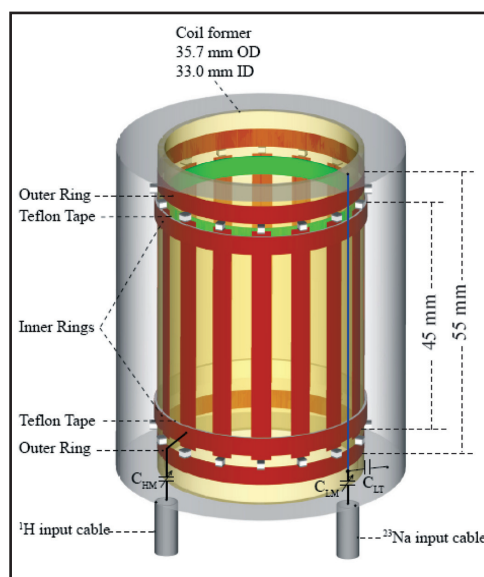

Figure 8. The sliding ring coil for $^1\text{H}/^{23}\text{Na}$ MRI at 21-T vertical bore magnet.

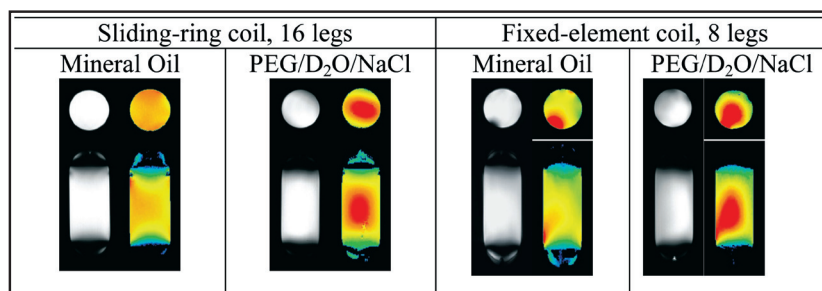
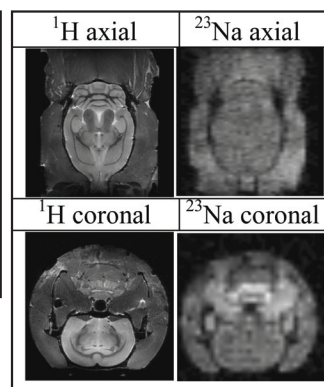

Figure 9. (above). The fast spin-echo (gray) and the tip angle map (color).

Figure 10. (right). The *ex vivo* rat head image obtained by multi-slice fast spin-echo from ^1H channel and 3D gradient refocusing echo from ^{23}Na channel.



• Prof. **Rafael Bruschweiler** from Florida State University and the NHMFL and Prof. **Michael Chapman** from the Oregon Health and Science University, have used residual dipolar couplings

to characterize the solution NMR structure of Arginine Kinase, the invertebrate homologue of the mammalian Creatine Kinase. These proteins are responsible for the production of adenosine triphosphate (ATP) from adenosine diphosphate (ADP) the critical source of chemical energy in living systems. Arginine Kinase is a 42 kDa protein, large for solution NMR standards and yet two complete sets of residual dipolar couplings for structural restraints were obtained using two different alignment protocols. These restraints in addition to the chemical shift analysis show that the apo state adopts a conformation (**Figure 11**) that is between the crystal apo (open form) and transition state (closed form) structures, with the secondary structure resembling the one of the transition state crystal structure. Thus two sets of RDCs and ϕ ψ torsion angles from the transition state crystal structure are used to refine the solution structure of apo AK. The results suggest that the solution structure of apo AK is mostly in the open form with the secondary structural elements closer to the transition state crystal structure.



Figure 11. 25 lowest structures of apo AK (backbone RMSD 0.9Å) refined with two sets of RDCs.

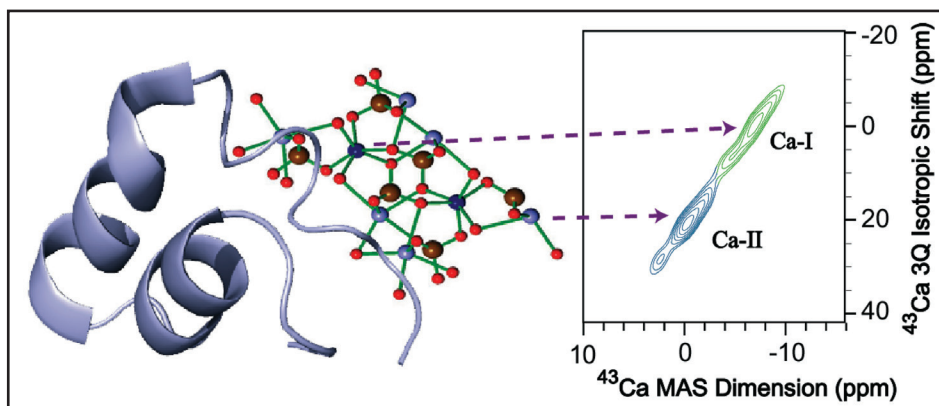

Figure 12.

Two-dimensional spectrum that correlates the ^{43}Ca chemical shift and a triple-quantum frequency of ^{43}Ca -enriched hydroxyapatite powder sample containing osteocalcin protein at 10 kHz MAS at room temperature.

- Prof. **D. Morris** at the University of Michigan teamed up with Dr. **Z. Gan** at the Magnet Lab to conduct ^{43}Ca studies on bone. Bone is a complex composite material system with a hierarchical structure. Understanding the molecular organization of bone at a high-resolution is of considerable current importance as it would provide valuable insights into the role of individual components on the strength and toughness of bone and could also provide a better understanding of degenerative joint diseases like osteoarthritis. In this study, the authors report the first demonstration of natural-abundance ^{43}Ca magic angle spinning (MAS) NMR experiments on bovine cortical bone and identify the presence of two different calcium sites (**Figure 12**).

Progress on STEM and Building the User Community

In 2009, we had 37 new senior investigators, of whom 11 lead the individual research projects. Of the 11 new user principal investigators, there were 14 requests for magnet time. None of these requests were denied.

The NMR Program is a multidisciplinary program integrating mathematics, physics, chemistry, biology, in addition to biomedical, mechanical, and electrical engineering. The user community similarly reflects this diversity of disciplines. While we continue to build our user community in both biological and materials solid state NMR spectroscopy, our ability to grow the community in solution NMR is decreasing, due to outdated instrumentation and the lack of infrastructure support. On a more positive note we are poised to increase users for magnetic resonance imaging. Excellent progress has been made in the past couple of years in developing the superb high field MRI technology and, with recent papers and presentations at international meetings, we anticipate a number of new MRI users in 2010.

User Facility: Advanced Magnetic Resonance Imaging Spectroscopy (AMRIS)

2009 statistics on AMRIS Facility users, projects, and magnet usage are presented in Appendix A.

The AMRIS facility at the University of Florida supports biological nuclear magnetic resonance studies of chemicals, tissues, small animals, large animals, and humans. We currently offer seven systems with different magnetic fields and configurations to users for magnetic resonance experiments, and AMRIS has eight professional staff members to assist users, maintain instrumentation, build new coils and probes, and help with administration.

Several of the AMRIS instruments offer users unique capabilities: *the 600 MHz 1-mm HTS cryoprobe is the most mass-sensitive NMR probe in the world* and is ideal for natural products; the 750 MHz wide bore provides outstanding high-field microimaging for excised tissues and live mice; *the 11.1 T horizontal MRI is the largest field strength magnet in the world* with a 400 mm bore; the 3 T human whole body has 16 channels for rapid parallel imaging and is *the only whole body instrument in the state of Florida dedicated to research*. These systems support a broad range of users from natural product identification to solid-state membrane protein NMR in lipids to cardiac studies in animals and humans to tracking stem cells and gene therapy *in vivo* to functional MRI in humans.

NMR & MRI Systems in the AMRIS Facility at UF in Gainesville			
¹ H Frequency	Field (T), Bore (mm)	Homogeneity	Measurements
750 MHz	17.6, 89	1 ppb	Solution/solid state NMR and MRI
600 MHz	14, 52	1 ppb	Solution state NMR and MRI
600 MHz	14, 52	1 ppb	1-mm HTS cryoprobe
500 MHz	11.7, 52	1 ppb	Solution/solid state NMR
500 MHz	11.1, 400	0.1 ppm	MRI and NMR of animals
200 MHz	4.7, 330	0.1 ppm	MRI and NMR of animals
130 MHz	3, 900 (600 mm useable bore)	0.1 ppm	MRI of whole body humans and large animals

Facility Developments

Joanna Long assumed leadership as AMRIS Director February 1, 2009, with **Glenn Walter** becoming the new AMRIS Associate Director. After seven years as AMRIS Director, **Art Edison** now serves as the NHMFL Director of Chemistry & Biology. This change in leadership serves to reinvigorate the AMRIS facility and the NHMFL as a whole.

As part of our commitment to animal imaging and spectroscopy and with the support of the McKnight Brain Institute, a position was created for an imaging scholar scientist for the AMRIS Facility. After a nationwide search, we were delighted to have Dr. **Huadong Zeng** join the AMRIS staff in December, 2009.

After successfully obtaining an NIH shared instrumentation grant, combined with ARRA funds to the NHMFL, we contracted for a new console and gradients for the 11.1 T/40 cm imaging magnet and a new animal MRI system at 4.7 T/33 cm with an actively shielded magnet. These consoles replace 12-15 year old RF technology, allowing us to capitalize on state-of-the-art digital technology for pulse sequence generation and data acquisition. The 4.7 T magnet was installed in January 2010 and the 11 T console is scheduled to be delivered in the summer of 2010. Both consoles will have multitransmit and receive capabilities and a new gradient set for the 11.1T system will increase its usable bore size to 29 cm.

Additionally, a new NIH grant was funded to support the development of the next generation HTS probe for natural products and metabolomics. Included in this grant were funds to purchase a new 600 MHz NMR console. The AMRIS Facility is partnering with the Chemistry Department at UF to purchase a new magnet for this console. The new 600 MHz NMR system will be administered by the AMRIS Facility and available through the NHMFL user program. We anticipate delivery of this system near the end of 2010.

Facility Plans

The world economic situation has had its impact on the AMRIS facility. Budgets are being cut at many levels, and for several years federal research funding has been severely limited. Some AMRIS users have had trouble maintaining funding, but with the ARRA we have seen research increase, particularly in biomedical

areas. Funding for basic research, which has led to many of the technical developments in AMRIS that enable our high field MRI/S applications, remains limited.

For the NHMFL user program, we will continue to offer services to all qualified users. In addition, through generous matching funds to AMRIS from the University of Florida, we continue three new technology cores to help build the Magnet Lab user program. These cores represent areas of unique strength in AMRIS in both hardware and in faculty expertise. **Glenn Walter** leads a core in molecular imaging that utilizes multimodal nanoparticles specifically designed for use at high magnetic fields. Glenn is developing optimal methods to use these particles to generate tissue and cellular contrast. **Steve Blackband** leads a core on microimaging. Through the development of microcoils and gradients in collaboration with Bruker Biospin this effort has led to the first MR images of mammalian tissues at cellular resolution (4-8 μm). **Art Edison** leads a core on high sensitivity NMR. The 1-mm HTS probe has served as the foundation of this effort, with AMRIS also supporting several other commercial and home-built small volume NMR probes. A recent NIH grant funded to build the next generation of HTS probe, optimized for ^1H and ^{13}C detection, will significantly increase the scope of this core.

Science Productivity

The AMRIS facility users reported 34 peer-reviewed publications for 2009. Some of the notable research highlights from 2009 include:

- **Flint, J.; Hansen, B.; Vertergaard-Poulsen, P. and Blackband, S.J.,** *Diffusion weighted magnetic resonance imaging of neuronal activity in the hippocampal slice model*, *Neuroimage*, **46** (2), 411-418 (2009).
- **Flint, J.J.; Lee, C.H.; Hansen, B.; Fey, M.; Schmidig, D.; Bui, J.D.; King, M.A.; Vestergaard-Poulsen, P. and Blackband, S.J.,** *Magnetic resonance microscopy of mammalian neurons*, *NeuroImage*, **46** (4), 1037-1040 (2009).

Magnetic resonance imaging (MRI) is now a leading diagnostic technique. As technology has improved, so has the spatial resolution achievable. In 1986 MR microscopy (MRM) was demonstrated with resolution in the tens of micrometers, and it is now an established subset of MRI with broad utility in biological and nonbiological applications. To date, only large cells from plants or aquatic animals have been imaged with MRM limiting its applicability. Using newly developed microsurface coils and an improved slice preparation technique for correlative histology, we report here for the first time direct visualization of single neurons in the mammalian central nervous system (CNS) using native MR signal at a resolution of 4–8 μm (**Figure 13**). Thus MRM has matured into a viable complementary cellular imaging technique in mammalian tissues.

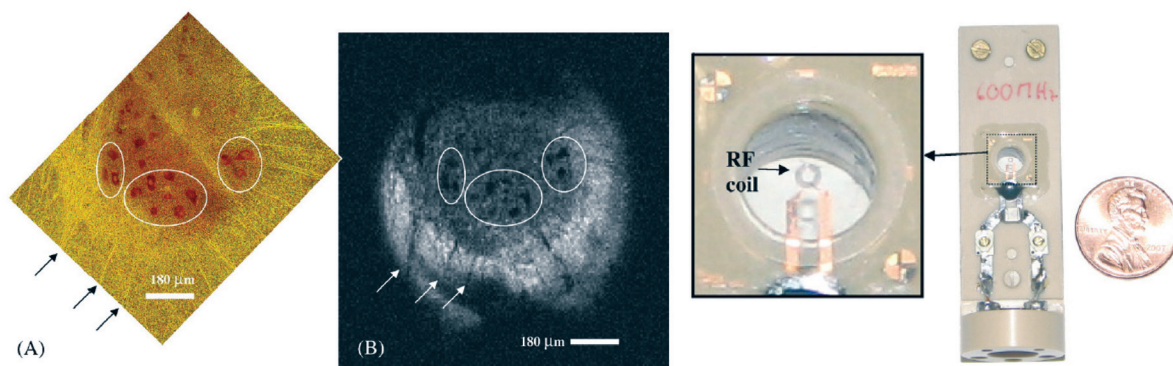

Figure 13

MR microscopy and histology of rat spinal cord tissue. (A) Nissl stained 25 μm section of the ventral horn in the rat spinal cord. (B) MR image (7.8 μm in-plane, acquisition time=7 h 7 min) of the tissue slice exhibited in (A). (C) Photograph of the 500 μm surface microcoil developed by Bruker, Switzerland (Z76409). The four-turn surface microcoil sits inside a 5 mm diameter, 500 μm deep tissue well better visualized in the expanded section on the left. A 200 μm coil was also employed.

- **Dalisay, D.S.; Rogers, E.W.; Edison, A.S. and Molinski, T.F.,** *Structure Elucidation at the Nanomole-Scale. Trisoxazole macrolides and Thiazole-containing cyclic peptides from the Nudibranch Hexabranchnus sanguineus*, *J. Natural Products*, **72**, 732-8 (2009)

A single specimen of *Hexabranchnus sanguineus*, a nudibranch from the Indo-Pacific that is known to sequester kabiramides B and C and other trisoxazole macrolides, yielded new kabiramide analogues, 9-desmethykbiramide B and 33-methyltetrahydrohalichondramide, and two new unexpected thiazole-

containing cyclic peptides in *submicromolar* amounts. The structures of these cyclic peptides were determined by analyses of 1D and 2D NMR spectra recorded with the 1-mm HTS cryoprobe, together with mass spectra. This is the first report of cyclic thiazole peptides from *H. sanguineus*. Since thiazole-oxazole-modified peptides are typically associated with cyanobacteria and tunicates, the finding may imply a dietary component of the *H. sanguineus* that was previously overlooked.

- **Bengtsson, N.E.; Brown, G.; Scott, E.W. and Walter, G.A.,** *lacZ* as a Genetic Reporter for Real-Time MRI, *Magn. Reson. Med.* **63**:745–753 (2010).

Molecular imaging based on MRI is currently hampered by the lack of genetic reporters for *in vivo* imaging. In this study it was demonstrated that a commercially available substrate *S-Gal*TM can be used to detect genetically engineered β -galactosidase expressing cells by MRI. β -galactosidase activity in the presence of *S-Gal*TM resulted in enhanced T2 and T*2 MR-contrast, which was amplified with increasing magnetic field strengths (4.7-17.6 T). Using both *lacZ*⁺ transgenic animals and *lacZ*⁺ tissue transplants, the authors were able to detect labeled cells in live animals in real time. See **Figure 14**. Similar to phantom studies, detection of the labeled cells/tissues *in vivo* was enhanced at high magnetic fields. These results demonstrate that the genetic reporter, *lacZ*, can be used as an *in vivo* marker gene using high-field-strength MRI.

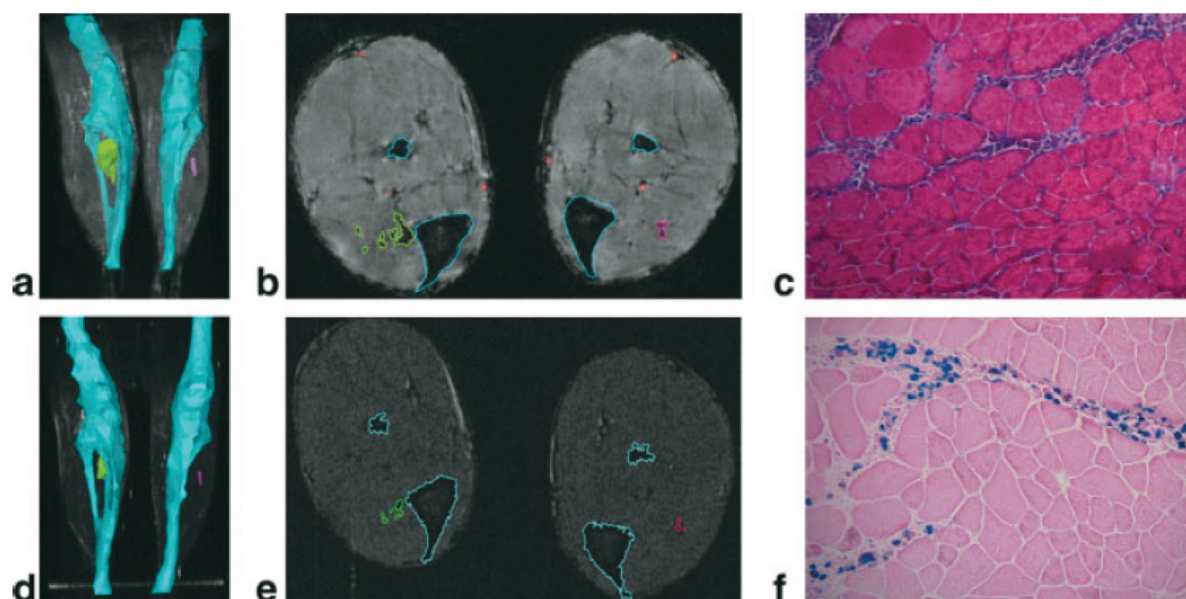

Figure 14.

The *in vivo* detection capability of *S-Gal*TM-labeled bone marrow cells increases with field strength. (a, d): 3D gradient echo data rendering from 11.1 T (a) showed a large region of signal void (green) at the site of *S-Gal*TM-labeled cell injection that was less pronounced at 4.7 T (d). A much smaller effect was observed in the right leg receiving labeled control cells (purple). (b, e): Representative MR cross-section of mouse hind limbs corresponding to the area of histology sectioning (same hind limbs imaged at (a) 11.1 T and (d) 4.7 T). Histology cross-sections of tissue injected with *S-Gal*TM-labeled bone marrow cells are shown with hematoxylin and eosin staining in (c) (40x) and with Prussian blue iron stain in (f) (40x).

Progress on STEM and Building the User Community

Of the 70 principal investigators who used AMRIS facilities in 2009, 15 of them were new user PIs.

Art Edison, professor and director of NHMFL Chemistry & Biology, travels to underrepresented colleges and universities as part of the NHMFL CO-WIN project. In 2009 he visited Claflin University in South Carolina. Dr. Edison also continues to run a weekly science club in Gainesville for disadvantaged children in grades 2-5, with 9-10 African American participants each week. With the assistance of two experts in education and 2-3 university student volunteers, the scope of this club has expanded to provide tutoring, develop social skills, and offer group activities in science and math. In March, 2009, Professor **Ian Castro-Gamboa** from Brazil joined Dr. Edison's laboratory for a one year sabbatical to use NHMFL instrumentation for plant natural product research.

User Facility: Electron Magnetic Resonance

2009 statistics on EMR Facility users, projects, and magnet usage are presented in Appendix A.

The Electron Magnetic Resonance (EMR) facilities at the NHMFL offer users several home built, high field and high frequency instruments providing continuous frequency coverage from 10 GHz to ~1 THz, with additional frequencies available up to 2.5 THz using a molecular gas laser. Several transmission probes are available for continuous-wave (c.w.) measurements that are compatible with a range of magnets at the lab, including the highest field 45 T hybrid magnet. Some of the probes can be configured with resonant cavities, providing enhanced sensitivity as well as options for *in-situ* rotation of samples in the magnetic field. Quasi-optical (QO) reflection spectrometers are also available in combination with dedicated high-resolution 12/17 T superconducting magnet systems; a simple QO spectrometer has also been developed for use in the resistive magnets (up to 45 T).

In addition to c.w. capabilities, the NHMFL EMR group boasts the highest frequency pulsed EPR spectrometer in the world, operating at 120, 240, and 336 GHz with 100 ns time resolution. A commercial Bruker Elexsys 680 operating at 9.7 and 95 GHz is available upon request. In the general science building, two superconducting magnets currently serve three spectrometers, as presented in the following table. EMR staff members also assist users in the DC facility using broadband tunable homodyne and heterodyne spectrometers. The combination of instruments may be used for a large range of applications, including the study of optical conductivity, cyclotron resonance, paramagnetic impurities, molecular clusters, antiferromagnetic and ferromagnetic compounds and thin films, optically excited paramagnetic states, etc.

EMR Systems at the Magnet Lab in Tallahassee										
Spectrometer	Frequency (GHz)	Field range (T)	c.w.-EPR	Pulsed	Time-Resolved	ENDOR	Rotation	Absolute Sensitivity ¹ at 290 K (spins/mT)	Concentration Sensitivity at 290 K (spin/cm ³ -mT)	Max. sample size (μl)
Transmission	23-660	0-17	■					10 ¹³	5×10 ¹³	200
Homodyne QO	190-670	0-17	■			■		5×10 ¹¹	2×10 ¹³	10
Heterodyne QO & transmission	120, 240, 336	0-12.5	■	■	■	■	■	10 ⁹ (in cavity) 2×10 ¹¹	5×10 ¹³ 2×10 ¹²	0.1 100
DC-field ² QO & transmission	50-900	0-45	■		■		■	10 ⁹ (in cavity) 10 ¹³	5×10 ¹³	200
Bruker X-band	9.7	0-1.5	■	■		■	■	10 ¹¹	10 ¹²	70
Bruker W-band	95	0-6	■	■		■	■	5×10 ⁸	10 ¹²	0.4

¹ The absolute sensitivity is the minimum number of detectable spins per mT linewidth and a 1 Hz bandwidth at room temperature.

² In combination with a far-infrared laser, selected frequencies up to 2500 GHz are available

Facility Developments

During the past 18 months, the EMR group has added many new capabilities to its user program, and many more are planned (some are funded, others are proposed) over the course of the next two to three years.

A 2nd EMR lab came online during the summer of 2009 with two new multi-high-frequency (8-700 GHz) heterodyne instruments for high field measurements. In addition, two new (funded) capabilities are planned for the next 1-2 years, including: a triple-axis superconducting vector magnet system; and sub-Kelvin temperatures.

Extended frequency coverage to 1 THz, using both Backward-Wave Oscillators (BWOs) and solid state sources that may be associated with Millimeter-wave Vector Network Analyzers.

Mössbauer spectroscopy: The EMR group has recently acquired an ⁵⁷Fe Mössbauer spectrometer that will eventually operate in conjunction with a 9 T magnet. This technique may be used to deduce important structural and chemical information. For example: the isomer shift is related to the electron density at the nucleus which, in turn, provides information concerning the Fe oxidation state, i.e. its spin state; the electric quadrupolar interaction splits the spectrum and provides information about electric field gradients and the site symmetry at the nucleus; and the nuclear Zeeman interaction further splits the spectrum, enabling studies of the local magnetism.

Plans for 2010

Biological Scholar Scientist. We have spent the past year and a half conducting an extensive international search for a fourth EMR scholar/scientist who can expand the scope of research within the group, particularly in the chemical and biological fields. Dr. **Likai Song**, who currently serves as the Director of the Structural Biology Core at the Dana-Farber Cancer Institute, Harvard Medical School, has accepted an offer to join the EMR group at the NHMFL starting in June 2010. Upon his arrival, Dr. Song will begin the process of taking over and expanding the biological side of our users program. This will include access to the commercial Bruker spectrometer. He will also work closely with the other scholar/scientists in cases where users require time on one of the high field spectrometers.

EMR Summer/Winter School. During the summer of 2009, the EMR group held a week-long summer school on theoretical and practical aspects of pulsed EPR. The school was attended by 20 graduate students and postdocs from the physics, chemistry, and biology departments both at Florida State University (FSU) and the University of Florida (UF). A series of formal lectures by faculty members from both UF and FSU took place each morning, followed by hands-on training in the afternoons on both commercial and home-built spectrometers. Based on the success of this first workshop, the EMR group plans to hold similar events in coming years that will be open to members of the EMR community in the United States and overseas. The next school has been proposed to take place during the winter of 2010/2011.

High-pressure EPR. Members of the EMR group received funding from the Chemistry Division at the NSF to develop capabilities for performing high-frequency EPR of samples subjected to hydrostatic pressures of up to 20 kbar.

Construction of a frequency domain magnetic resonance spectrometer. A new instrument is being setup to cover a very broad frequency range (70-1500 GHz), initially for zero-field experiments and later for operation in a split-coil magnet.

Enhanced pulsed EPR capabilities: The EMR group is working with groups in the United States and the United Kingdom to obtain funding for the necessary high-power microwave sources/amplifiers and quasi-optical components to build the next generation pulsed spectrometer for the NHMFL operating above 95 and 220 GHz.

BigLight. The EMR group continues to be very active in developing a proposal to support construction of a major THz/infrared accelerator-based light source at the DC field facility in Tallahassee. For more info: <http://www.magnet.fsu.edu/usershub/publications/biglight.html>

Science Productivity

In 2009 a large number of research groups and projects were accommodated by the EMR group, resulting in the submission of 45 research reports. In addition, 40 peer-reviewed journal articles were reported by our users, as well as numerous presentations at conferences. Many publications appeared in high-impact journals including: 5 in *Physical Review Letters*; 6 in the *Journal of the American Chemical Society*; 5 in *Physical Review B*; 5 in *Inorganic Chemistry*; and 2 each in *Dalton Transactions in Chemistry and Biochemistry*. Projects spanned a range of disciplines from applied materials research to metallo-proteins. A few examples are given below.

- **Coherent Manipulation of Mononuclear Lanthanide-Based Single-Molecule Magnets.** This work was performed by **S. Datta**, **S. Ghosh**, **J. Krzystek**, and **S. Hill**, in collaboration with **S. Cardona-Serra** and **E. Coronado** from the University of Valencia. Rare-earth ions encapsulated in polyoxometallate (POM) cages offer tremendous potential in the context of molecular spintronics and quantum information processing [**AIDamen, M.A.**, *et al.*, *J. Am. Chem. Soc.*, **130**, 8874 (2008); *Inorg. Chem.*, **48**, 3467 (2009)]. Pulsed EPR measurements carried out in the EMR lab demonstrate the possibility of coherent manipulation of holmium spins in these novel POM nano-magnets. Of particular importance is the fact that the Ho nucleus goes along for the ride, thus mitigating a notorious process that destroys quantum information. (**Figure 15**)

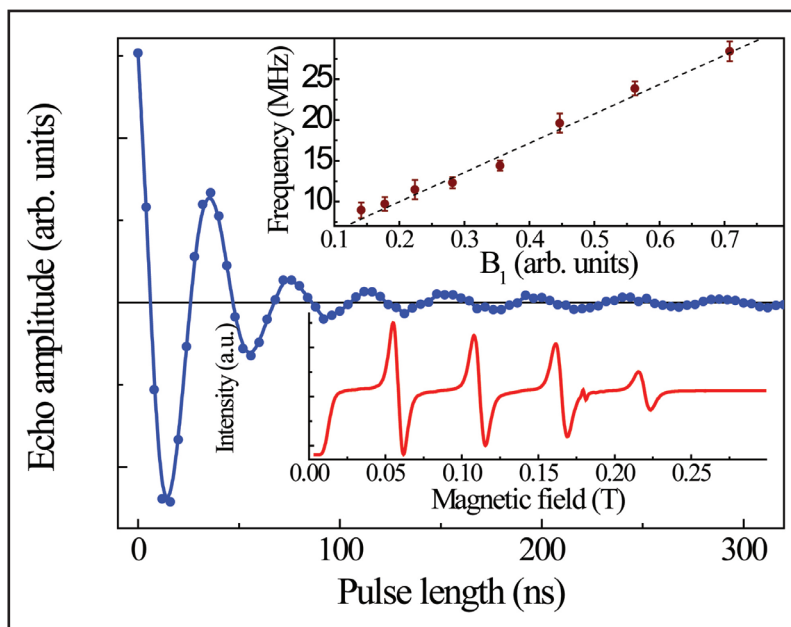

Figure 15.

Electron-spin-echo amplitude versus nutation pulse length, revealing coherent Rabi oscillations at $T = 5$ K. Upper panel: Rabi frequency plotted versus the microwave B_1 field. Lower panel: continuous-wave spectrum.

- High-Field EPR and Magnetic Susceptibility Studies on Tetranuclear Ferromagnetic Quinoline Adducts of Copper(II) Trifluoroacetate.** Copper(I) and copper(II) perfluorocarboxylates are volatile, which makes them potentially useful in the chemical vapor deposition technique to produce thin metallic copper layers and, from this viewpoint, a determination of the nuclearity of such complexes is very important. The use of high-field EPR spectroscopy has enabled studies of some unprecedented solid-state transformations of dimeric and tetrameric complexes of copper(II) perfluorocarboxylates [A. Ozarowski *et al.*, *J. Am. Chem. Soc.*, **131**, 10279-10292 (2009)]. In one example, an antiferromagnetic dimer converts reversibly to a tetramer; in a second example, an irreversible solid-state conversion of a ferromagnetic tetramer into an antiferromagnetic tetramer is seen. This work was performed by I. B. Szymańska and T. Muzioł, from Nicolaus Copernicus University, together with J. Jezierska from Wrocław University and A. Ozarowski (NHMFL). (Figure 16)

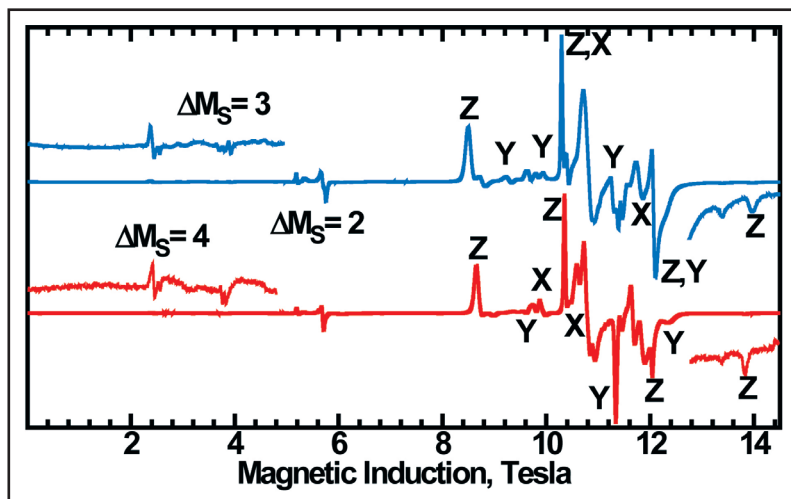

Figure 16.

EPR spectra of the toluene (bottom) and benzene (top) solvate of $\text{Cu}_4\text{O}(\text{CF}_3\text{COO})_6(\text{quinoline})_4$ at 15 K and 324 GHz. Both compounds exhibited identical g values $g_x = 2.168$, $g_y = 2.173$, $g_z = 2.066$, but differed in zero-field splitting parameters $D = 0.827$, $E = 0.114$ and $D = 0.875$, $E = 0.049$ cm^{-1} for the toluene and benzene solvate, respectively.

- HFEPR Studies on Dinuclear Complexes Relevant to Purple Acid Phosphatase Enzymes.** This work, involving users from Roosevelt University, IL, and Brazil (Universidade Federal de Santa Catarina), reports on a high-frequency and field Electron Paramagnetic Resonance study of a dinuclear complex formed by Fe(III) and Co(II) with a novel asymmetrically binucleating ligand H_2 BPBPMP. This complex serves as a biomimetic model for the reaction center of an important class of metalloenzymes known as purple acid phosphatases (PAP), which are found to perform phosphate ester hydrolysis in many organisms, including humans. In particular, the nature of magnetic coupling between the two metal ions, which are found to be in a high-spin state, is related to the catalytic function of the enzyme. (Figure 17)

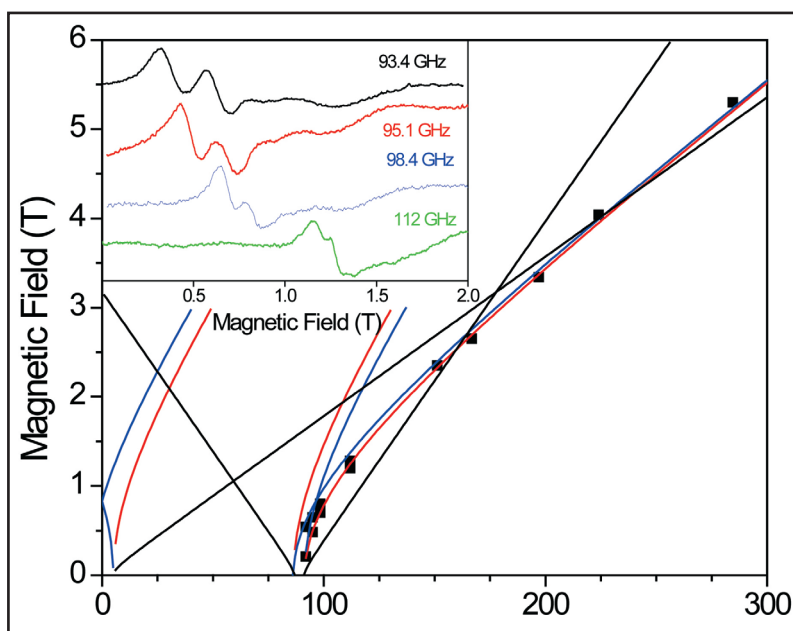

Figure 17.

(Inset) EPR spectra of [FeCo] at $T = 10$ K and indicated frequency. (Main plot) 2-D field/frequency map of EPR transitions; squares are experimental points; lines were calculated using: $S = 1$, $|D| = 2.97$ cm^{-1} , $|E| = 0.09$ cm^{-1} , $g_x = g_y = 1.85$, $g_z = 2.00$. The red lines denote the turning points with $B_0 \parallel x$; blue lines, $B_0 \parallel y$; black lines, $B_0 \parallel z$.

Progress on STEM and Building the User Community

In 2009, the EMR group received 20 applications for magnet time from first time users (new user principal investigators) out of a total of 53 requests, i.e. 38% of our applications were from first time users. All of these requests were accommodated. In addition, of the 53 requests received 19% were from either female (11%) or minority (8%) PIs, while nearly one-third of our total number of users was from underrepresented groups (18% female and 10% minority).

In an effort to attract new users, the EMR group continues to provide up to \$500 of financial support to first time visitors to the lab. In addition, members of the EMR group made aggressive efforts to advertise the facility at international workshops and conferences. These efforts included attending conferences outside of our own immediate research areas. The group has also organized several workshops and symposia and provided financial support in the form of student travel grants for the two main EPR conferences in the United States. Finally, we organized our own 1-week EPR summer school for the first time in 2009. We plan to continue this series of student workshops in the coming years as a means of outreach to the international EPR community.

User Facility: Ion Cyclotron Resonance

2009 statistics on ICR Facility users, projects, and magnet usage are presented in Appendix A.

During 2009, the Fourier Transform Ion Cyclotron Resonance (ICR) Mass Spectrometry program continued instrument and technique development, as well as pursuing novel applications of FT-ICR mass spectrometry. These methods are made available to external users through the NSF National High-Field FT-ICR Mass Spectrometry Facility. The facility features five staff scientists who support instrumentation, software, biological applications, petrochemical and environmental applications, and user services, as well as a machinist, technician, and several rotating postdocs who are available to collaborate and/or assist with projects.

ICR Systems at the Magnet Lab in Tallahassee		
Field (T), Bore (mm)	Homogeneity	Measurements
14.5, 104	1 ppm	ESI, APPI FT-ICR
9.4, 220	1 ppm	ESI, APPI FT-ICR
9.4, 155	1 ppm	FD, LD FT-ICR
7, 155	1 ppm	EI, CI FT-ICR

Facility Developments

An actively-shielded 14.5 T, 104 mm bore system-offers the highest mass measurement accuracy (<300 parts-per-billion rms error) and highest combination of scan rate and mass resolving power available in the world [*Anal. Chem.*, **80**, 3985-3990 (2008)]. The spectrometer features electrospray, atmospheric pressure photoionization (APPI), and atmospheric pressure chemical ionization sources; linear quadrupole trap for external ion storage, mass selection, and collisional dissociation (CAD); and automatic gain control (AGC) for accurate and precise control of charge delivered to the ICR cell. The combination of AGC and high magnetic field make sub-ppm mass accuracy routine without the need for an internal calibrant. Mass resolving power > 200,000 at m/z 400 is achieved at one scan per second, which is ideal for LC-MS. Robotic sample handling allows unattended or remote operation. An additional pumping stage has been added to improve resolution of small molecules. Simultaneous infrared multiphoton (IRMPD) and electron capture dissociation (ECD) are under development.

The 9.4 T, 220 mm bore system offers a unique combination of mass resolving power ($m/\Delta m = 8,000,000$ at mass 9,000 Da) and dynamic range (>10,000:1), as well as high mass range, mass accuracy, dual-electrospray source for accurate internal mass calibration, efficient tandem mass spectrometry (as high as MS⁸), and long ion storage period. The magnet is passively shielded to allow proper function of all equipment and safety for users. The system features external mass selection prior to ion injection for further increase in dynamic range and rapid (~100 ms timescale) MS/MS [*Anal. Chem.*, **75**, 3256-3262 (2003)]. Available dissociation techniques include collisional (CAD), photon-induced (IRMPD) and electron-induced (ECD) [*J. Am. Soc. Mass Spectrom.*, **20**, 1182-1192 (2009)]. A robotic sample-handling system allows unattended and geographically remote operation. Both APPI and APCI are available for analysis of nonpolar analytes and three automated HPLC interfaces are available for maximum utilization of our instruments [*J. Am. Soc. Mass Spectrom.*, **20**, 2183-2191 (2009)].

The 9.4 and 7 T actively shielded FT-ICR instruments are available for analysis of complex nonpolar mixtures and instrumentation development. The 9.4 T magnet is currently used for elemental carbon cluster analysis. The 7 T magnet is optimized for volatile mixture analysis [*Rev. Sci. Instrum.*, **77**, 025102 (2006)] and can be used to develop ion optics and ICR ion traps. Samples are volatilized in a heated glass inlet system (at 200-300 °C) and externally ionized by an electron beam (0-100 eV, 0.1-10 μA). The ions are collected in a linear multipole ion trap and injected into the FT-ICR cell. Mass resolving power ($m/\Delta m$) greater than 10⁵ and mass accuracy within 1 ppm has been achieved with both systems. Thousands of components in a complex mixture (e.g., petroleum distillates) can thus be resolved and identified.

Science Productivity

- **Biomolecular sequence verification** continues to be in high demand. Protein and oligonucleotide masses can be determined with ppm accuracy. Molecules can be fragmented (by collisions, photons, or electron capture by multiply-charged positive ions) to yield sequence-specific products [*Mol. Biol. Cell.*, **113**, 7779-7783 (2009)]. Sites and nature of post-translational modification (e.g., glycosylation, phosphorylation, etc.) are readily determined [*Proteomics*, **4**, 970-981 (2004)]. In-house software has been developed for rapid data analysis. We devised a method to distinguish N-terminal from C-terminal peptides by use of electron capture dissociation MS/MS [*Anal. Chem.*, **79**, 7596-7602 (2007)], as well as the first large-scale characterization of hundreds of membrane lipids from cell cultures [*Anal. Chem.*, **79**, 8423-8430 (2007)].
- Tertiary and quaternary structure can also be probed. Automated **hydrogen/deuterium exchange** has been improved through increased throughput of proteolysis [*J. Am. Soc. Mass Spectrom.*, **20**, 520-524 (2009)]. Details of biomolecular conformation and surface contact between molecules in a noncovalent complex can be deduced. For example, we were able to characterize the nature of the interaction of a biological "motor" that injects single-stranded RNA into the capsid (shell) of a bacteriophage virus [*Virology*, **351**, 73-79 (2006)].
- The 7, 9.4, and 14.5 T instruments are primed for immediate impact in **environmental, petrochemical, and forensic analysis**, where intractably complex mixtures are common. For example, post-blast soil samples can be extracted and compared with a library of commercial and military explosives to identify the active agent and the source of the product [*Anal. Chem.*, **74**, 1879-1883 (2002)]. Characterization of dissolved organic matter in natural waters is critical to understanding the global carbon distribution [*Limnol. Oceanogr. Methods*, **7**, 81-95 (2009)]. The new field of "petroleomics" has been developed largely due to the unique ability of high-field FT-ICR mass spectrometry to resolve and identify all the components in petroleum samples [*Proc. Nat. Acad. Sci.*, **105**, 18090-18095 (2008)]. Recent automation of petroleum characterization has been implemented to electrospray ionization [*J. Am. Soc. Mass Spectrom.*, **20**, 263-268 (2009)]. Applications to the composition of crude oil as a function of boiling point have been explored to the upper limit of distillation [*Energy & Fuels*, **23**, 314-319 (2009)]. Characterization of the structure of vanadyl porphyrins in an unfractionated crude oil has led to increased speciation of the various trace metals present in petroleum products. [*Energy & Fuels*, **23**, 2122-2128 (2009)]. Calcium and sodium naphthenate deposits can be characterized to provide critical information about their structure and functionality to prevent formation [*Energy & Fuels*, **23**, 349-355 (2009)]. Further, fossil fuel samples can be analyzed and components resolved without chromatographic separation. In a recent study more than 12,000 distinct chemical components were resolved and identified (elemental formulas) in a single atmospheric pressure photoionization FT-ICR mass spectrum of crude oil [*Anal. Chem.*, **78**, 5906-5912 (2006)].

Progress on STEM and Building the User Community

The ICR facility conducted research with 21 new user PIs and supported instrumentation development with several research groups.

In January 2008 the ICR program arranged (in collaboration with colleagues at Pacific Northwest National Laboratory) and hosted a workshop on the next generation of high performance FT-ICR mass spectrometry. More than 30 researchers from academia, industry, and government labs shared their latest results and future visions. In 2009, NSF granted the ICR facility funds to begin development of the first 21 T FT ICR-MS system.

User Facility: Geochemistry

2009 statistics on Geochemistry Facility users, projects, and magnet usage are presented in Appendix A.

The geochemistry facility has six mass spectrometers of which four are available to outside users. One instrument is a multi collector thermal ionization instrument (Finnegan MAT 262/RPQ) that is used for measurements of isotopes of elements with low first ionization potential. The second instrument is a single collector inductively coupled plasma mass spectrometer (ICP-MS), ELEMENT, which is used for trace metal abundance determinations. A separate laser ablation system can be interfaced for *in-situ* trace element analyses on solid materials. The third instrument is a multi collector inductively coupled plasma mass spectrometer (NEPTUNE) which is used for determination of isotopic abundances of metals. The fourth instrument is a mass spectrometer designed for the measurement of the light stable isotopes (C, N, O, S).

The facility is run off of external grants and in the last year individual PIs had funding from NSF (several divisions of the GEO directorate), NASA, NOAA, and EPRI (Electrical Power Research Institute).

Facility Developments

Facility developments during the year involved mostly the now 15-year-old Finnegan MAT 262/RPQ thermal ionization mass spectrometer. We have gradually shifted most of the measurement routines from this old mass spectrometer to the NEPTUNE ICP-MS. This can now be noted in the decrease in instrument time on the 262. In April 2009, we lost the engineer we depended upon for technical support. The FSU College of Arts and Sciences has not been willing to fund a replacement yet.

Facility Plans

Our plan is to replace our now aging ICP-MS ELEMENT with a new instrument. Before we can write a proposal for the replacement we have to solve our technical support issue.

Science Productivity

In 2009 we published 10 peer-reviewed publications and made 22 presentations at international meetings. In addition three students defended their Ph.D., while one student received a MSc degree. Our funding diversified, and we were successful in grant application to NOAA and the Electrical Power Research Institute (EPRI).

This year there are **two very significant achievements that merit special mention**. Both studies concern climate change studies.

This year we saw the completion of a study of lithium isotopes in foraminifera²¹ that provides *the first comprehensive Li-isotope record of seawater for the Cenozoic*. The Li-isotopic composition of seawater is thought to be most sensitive to silicate weathering. The correlation of Li-isotopes with other indicators of climate change like Ca, Sr, and O isotopes indicates that change in surface temperatures are related to changes in weathering rates and these rates can be quantified. This is a big step forward in our understanding of the response of the Earth as a system to climate change.

The second study concerns *the study of the effect of thawing of the arctic permafrost*. There are large organic carbon stores in permafrost and in northern peatlands. These reservoirs are significantly greater than the amount of carbon in the atmosphere as carbon dioxide. The changing climate (warming) is resulting in respiration of this carbon and its release to the atmosphere as carbon dioxide and methane. The research from our laboratory demonstrates that due to anaerobic respiration of organic matter, the permafrost carbon is being predominantly released as methane, a greenhouse gas 25 times more powerful than carbon dioxide.

Progress on STEM and Building the User Community

Since we have lost both our engineer and laboratory manager in the last two years, we are not in the position to expand our user base at the moment. New students / users from the FSU Department of Chemistry and Biochemistry were accommodated.

The facility continues to be open to all qualified users, and we have a long-time collaboration with the USGS Volcano Monitoring Program. As our facilities are supported through external grants, external users have to be able to contribute to the cost of the lab use. However, we continue to help people get preliminary data for use in proposals etc. free of charge. Also, training of new users on the instruments is done without charging for technician time or instrument time.

During the summer we hosted two undergraduate students from the REU program. We also participated extensively in the 2009 Magnet Lab Open House.

Chapter 4: Magnets & Magnet Materials

Introduction

A central enabling feature of the NHMFL's success to-date and its prospects for success in the future is the availability of unique high-performance magnet systems that exploit the latest materials and magnet design developments. As we move forward, pursuing ever higher fields while controlling costs, continued hand-in-glove developments on these fronts is built in to our program. The program contains a balance of ongoing magnet construction and long range materials and magnet R&D aimed at developing new magnet technologies.

Especially in **superconducting magnet technology**, we are using our knowledge and connections to the rapidly advancing high temperature superconductor (HTS) community to drive HTS magnet and conductor technology in the spirit of the 2005 Committee on Opportunities in High Magnetic Field Science (COHMAG) report, which laid out ambitious 10-15 year goals for magnet technology. One of its goals, the progress towards an all superconducting 30 T NMR magnet is being advanced by the start of construction on an all superconducting (but smaller and simpler magnet since it is not of NMR field quality) 32 T user magnet for the NHMFL. A second recommendation of COHMAG was for much greater inter-institutional collaboration in new magnet technologies. In 2009 we started a new 2-year collaboration of 6 institutions, Very High Field Superconducting Magnet Collaboration (VHFSMC), jointly led from Fermilab and the NHMFL, to evaluate round wire Bi-2212 for high field superconducting magnets suitable for High Energy Physics applications.

The most immediate impact to the user community is the developments in **pulsed magnets** at the Los Alamos branch. *The 85 T pulsed magnet returned to service providing >150 pulses, numbers that are unmatched elsewhere!* The capacitor-driven insert wore out in June and the spare was installed in September. Insert #2 is now in service at 85 T and has provided over 80 high field pulses. A new insert is being designed that is expected to allow operations in late 2010 at 95 T or higher in a 10 mm bore.

In the **resistive magnet** program, the first of the workhorse 32-mm-bore magnets was upgraded to 36 T using a new stacking technique. We anticipate upgrading additional magnets as they wear out in the coming years. 2009 also saw the completion of the design of *a novel split resistive magnet that will provide a world-record magnetic field (25 T vs. 18 T elsewhere) along with uniquely large mid-plane ports for scattering experiments!* Fabrication of this magnet is now underway and the system should be ready for user service in early 2011.

The NHMFL is one of the world's leading institutions in the design and fabrication of magnets using **cable-in-conduit conductor** (CICC). Presently we are constructing new hybrid magnets for the NHMFL and for the Helmholtz Center Berlin (HZB), Germany, as well as designing an all-superconducting magnet for the Spallation Neutron Source (SNS) in Oak Ridge, Tennessee. The NHMFL magnet will be used for NMR experiments in addition to more traditional high field experiments, and the HZB and SNS magnets will be used for neutron-scattering experiments. *2009 brought many milestones, principally:* (1) the delivery of roughly half the Nb₃Sn strand required for the HZB and NHMFL magnets, (2) completion of the design of the CICC coils and cold-mass for both systems, (3) completion of specifications for refrigeration systems at both Tallahassee and Berlin, (4) cabling of 2 of the 10 lengths of CICC, (5) testing of 20 kA joints between CICC, and (6) completion of the design of the cryostat for HZB. The NHMFL and HZB systems are expected to be complete in 2012, and a proposal for construction of the SNS magnet was submitted in July 2009.

Present magnet designs for pulsed, resistive, and superconducting systems are limited by either the strength, stiffness, or fatigue life of the available **materials**. The NHMFL plays a leading role in the development of conducting, superconducting, and structural materials for all types of magnets, particularly since the arrival of the Applied Superconductivity Center in 2006. In 2009 materials research spanned a gamut of techniques and applications. BiSCCO wire and coil reaction processes potentially useful for 30 T-class NMR magnets were developed. Pinning mechanisms and the effects of and grain boundaries were studied in YBCO and ferropnictide superconductors. Mechanisms affecting strength and conductivity of high-strength copper alloys for resistive and pulsed magnets were discovered. The International Thermo-nuclear Experimental Reactor (ITER) funded studies of fatigue and embrittlement of stainless steels for CICC magnets as well as studies of the strain sensitivity of Nb₃Sn wire. Theories were developed regarding the nonlinear surface resistance of Nb cavities for accelerators.

More information on these activities appears in this chapter as follows:

Pulsed Magnets, page 86

Resistive Magnets, page 87

High Strength Materials, page 88

Superconducting Magnets, page 89

Superconducting Materials Development, page 91

CICC Magnets, page 95

Pulsed Magnets

The NHMFL pulsed magnet group is responsible for development and operation of both generator and capacitor driven pulsed magnet systems. The mission is in direct response to the NSF charges to provide the highest fields for science, and develop new magnet technology. Work in 2009 primarily focused on: (1) Refining 85 T operations and diagnostics procedures for the 100 T Multi-Pulse Magnet system, (2) production of user magnets for the NSF Pulsed Field Facility, (3) the development of the next-generation duplex-magnet technology, and (4) design definition of the insert magnet upgrade for the 100 T Multi-Pulse Magnet. The insert upgrade will enable pulsed magnet operations to reach field intensities in the 95 T to 100 T range.

100 T Multi-Pulse Magnet System. The 100 T Multi-Pulse Magnet System is a long-term partnership jointly funded by the U. S. Department of Energy - Office of Basic Energy Science, and the National Science Foundation - Division of Materials Research. *This magnet holds the world-record field, 88.9 T, and the record for continuous non-destructive pulsed operations, >150 pulses.* The magnet is presently a unique unmatched resource for high field scientific research. The primary accomplishment in 2009 was the successful demonstration of continuous 85 T operations in support of user science. The NSF user program supported six science experiments selected by a competitive proposal process.

100 T magnet operations are maturing in both definition and predictability. We have implemented systematic diagnostic monitoring of coil resistances to ensure more reliable operations. The 100 T magnet was designed such that the inner insert magnets are replaceable. One of the functional requirements of the insert magnets is that their electrical fault behavior is non-destructive to the outer magnet assembly. The first insert experienced electrical fault during an 85 T pulse in June 2009. The insert's fault behavior was non-destructive validating the failure-mode design and matching the behavior of over 10 previous electrical faults in previous prototypes. **Figure 1A** presents a summary of the performance of the first insert magnet.

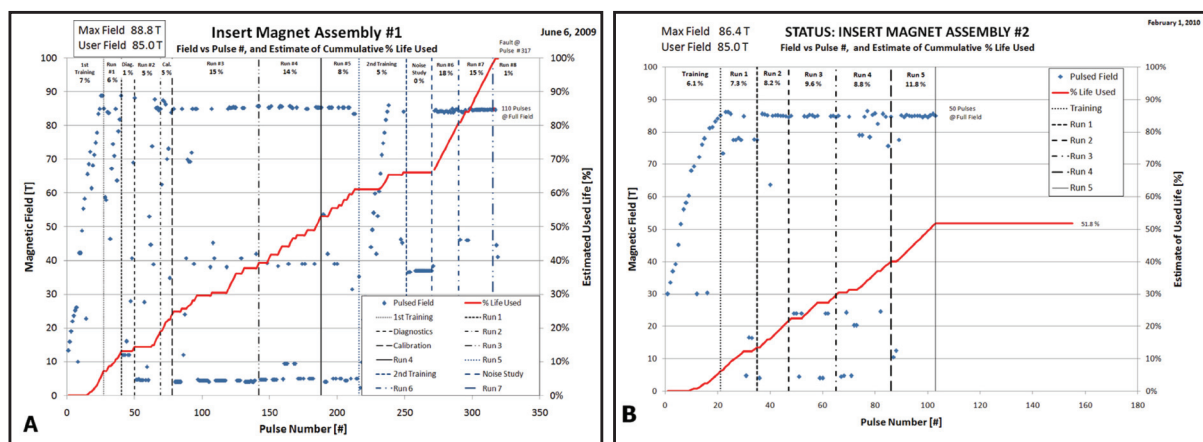

Figure 1.

Summary of insert magnet operations at 85 Tesla. (A) Performance data for first insert #1. (B) Performance data for insert #2. Magnet lifetimes are estimated for insert #2 based upon the performance of insert #1.

Post-fault inspection of insert #1 indicated possible deficiency in reinforcement construction in layer 7. The reinforcement process was modified to address technical concerns during the construction of the second insert magnet. The pulsed magnet group installed insert #2 in September 2009. NSF user science activities resumed during October 2009. **Figure 1B** presents a summary of operations with insert #2. Operations at 85T are a reality at the NHMFL Pulsed Field Facility.

The next insert upgrade is designed to reach magnetic fields between 95 T and 100 T in a 10 mm bore. The magnetic design of the upgrade insert was finalized during 2009. Construction of the first upgrade insert is planned for the third quarter of 2010. The critical issue that will determine the maximum attainable field is the feasibility of extending the outsert magnet's field from 37 T to 42 T. Activities in 2010 will entail a detailed review of the outsert design after the 2008 upgrade to determine the risks associated with increasing field production from the outsert.

Duplex Magnet Development for the Next Generation of User Magnets. The NHMFL has designed a first generation of duplex magnets for operation with the new 4 MJ capacitor bank at the LANL facility. Programmatic planning in 2009 adjusted priorities to emphasize the production of a 15 mm bore duplex magnet to replace the present generation of 65 T user magnets. The design adopted is calculated to ultimately operate at 80 T. Construction of the first duplex magnet will start during the second quarter of 2010. Duplex magnet operations will initially be at 70 T to establish an operations profile, reliability, and fault behavior.

NSF User Magnet Production. The pulsed magnet group supports the operation of five scientific user stations and the production of capacitor-driven inserts for the 100 T Multi-Pulse Magnet Program. The 2009 work for the NSF Science Program entailed the delivery of six 65 T pulsed magnet assemblies.

Additional Pulsed Magnet Activities. The pulsed magnet group also was engaged in collaborative projects with internal LANL and external groups in U.S. industry. In 2009 a set of cryogenic pre-polarization pulsed magnets were designed and constructed for a SQUID magnetometer based MRI imaging and chemical analysis system funded by U.S. Department of Homeland Security (DHS). This is the second project performed for DHS by the LANL pulsed magnet group. The first SQUID-based imaging system project, performed in 2008, was awarded a R&D 100 for innovation. Planned collaborations in 2010 will entail the development of pulsed pre-polarization coils using HTS technology in support of a neural current imaging project at Los Alamos.

Resistive Magnets

Split 25 T Magnet. A novel split magnet is being developed for photon scattering experiments at the Magnet Lab that *will provide world record magnetic field* (25 T vs. 18 T available elsewhere) along with uniquely large mid-plane ports for scattering (four ports providing 0.5 steradians of solid angle). In addition, the magnet can be operated either with the field vertical or, by tilting the magnet housing, with the field horizontal. The magnet consists of 4 coils in electrically series. The innermost coil consists, in turn, of two sub-coils electrically in parallel. In a split solenoid, the magnet must accommodate numerous conflicting constraints; over half the mid-plane must be devoted to vacuum space. The remainder must include (1) sufficient structure to support ~500 tons of force between the two halves of the magnet, (2) sufficient conductor to carry 160 kA between the two halves, and (3) sufficient free space to carry 220 liters per second of cooling water. To address these constraints a new magnet technology, the Split Florida-Helix, has been developed and patented for use in this magnet and is employed at the mid-plane of the innermost coils. Finite element analysis served as the essential tool guiding the design optimization of the overall system and the various components. The November 2009 NHMFL Users Committee meeting included a full day devoted to discussing the magnet and cell configuration with the user community. A design review has been held, and procurement of materials and the fabrication of the major components have started. We expect to have the complete system serving users in early 2011.

Solenoid Upgrades. While the NHMFL has provided the highest field resistive magnets worldwide since 1994, in recent years labs in Europe have started to provide similar fields. In December 2009, a new 32 mm bore resistive magnet reached 36 T using 20 MW of dc power. This is a full tesla higher field than is available anywhere else, and it uses less power than competing systems. This new magnet was realized by modifying a 35 T magnet and employing an irregular stacking sequence that allows power to be transferred from the outer coils to the inner ones without increasing the stress level, thereby raising the overall efficiency. In coming years we intend to implement similar upgrades of 1 T in most of the magnet cells as the existing coils expire.

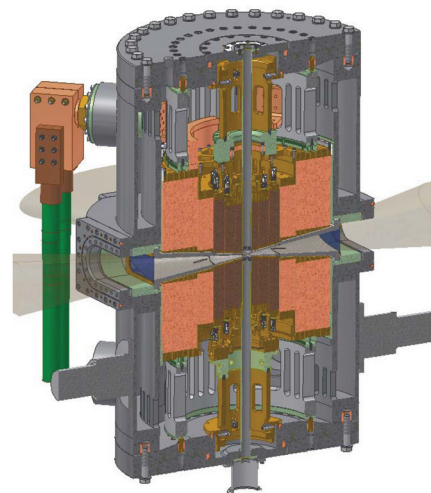

Figure 2.
3D model of the Split magnet

High Strength Materials

High field electromagnets entail the combination of high current densities and high magnetic fields and the resulting extremely large Lorenz forces. Present magnet designs for pulsed, resistive and superconducting systems are limited by either the strength, stiffness, or fatigue life of the available materials. In addition, magnets undergo unusual fabrication procedures including heat treatments and unusual operating conditions such as cryogenic service. Therefore, *development of higher field magnets requires us to undertake materials research both characterizing existing materials and developing new materials suitable to these unique environments.*

Structural Materials. In 2009, researchers in the Magnet Lab have published several papers related to structural materials for high field magnets. Those structural materials have the face-centered cubic (fcc) structure and are considered to have good mechanical properties at cryogenic temperatures required for high field magnets.

Austenitic stainless steels have been used extensively in highly-stressed superconducting magnet components for many years. 316LN is used in particular as its increased N content increases strength while its reduced C content increases critical stress intensity factor and fracture toughness [C. Nyilas *et al.*, *Advances in Cryogenic Engineering*, **50**, 176 (2004)]. Work at the NHMFL in recent years has shed new light on these materials, particularly in the context of conduit materials for cable-in-conduit conductors (CICC) for the SCH and ITER that require a K_{Ic} of 100 to 200 $\text{MPa}\cdot\text{m}^{1/2}$. **Figure 3** shows a comparison of critical stress intensity factor/fracture

toughness values measured at 4 K as a function of 973 K reaction time (required to form Nb_3Sn during CICC react-and-wind process). Clearly the reduction in critical stress intensity factor is dramatically influenced by the carbon content of the material, with low content giving the least reduction. While it was previously thought that C content lower than 0.02% was adequate for CICC applications, our data indicates that values less than 0.01% should be specified. In addition, it was previously believed that N contents up to 0.2% were acceptable; our data indicates values between 0.14 and 0.16% should be attained.

The fracture mechanisms were found to be related to the formation of grain boundary precipitates of large Cr_2N and/or small $(\text{Fe,Cr,Ni,Si})_2\text{Mo}_{1-x}$. Thus, steels with high nitrogen content may also have low fracture toughness, contrary to previous thinking. Other factors also contribute to the mechanical properties of this material. For instance, the grain size plays a major role in change of the critical stress intensity factor's fracture toughness. Our results indicate that reduction of the grain size reduces the 4 K critical stress intensity factors. This result is different from the prediction of the materials with soft zones at the grain boundaries by previous researchers [E. Hornbogen, M. Graf, *Acta Metall.*, **25** (8), 877–881 (1977)]. In addition, we find that decreasing of the grain sizes also shortens the onset of the sensitization time. Based on our experimental observations and fundamental understanding of the materials properties, we have developed a semi-empirical equation to relate the chemistry and the microstructure to fracture toughness in 316LN type stainless steels. The equation indicates that reduction of the carbon and nitrogen content and increase of grain size improves the fracture toughness values in sensitized 316LN. The fatigue life of the materials can be measured and estimated by crack growth rates. It is found that the formation of grain boundary precipitates due to the aging have no impact on the crack growth rates at intermediate stress intensity amplitude (ΔK) range in low-carbon, high-nitrogen stainless steels. This indicates that in this ΔK range, the stress concentration resulting from the grain boundary precipitates is too small to cause any intergranular crack propagations.

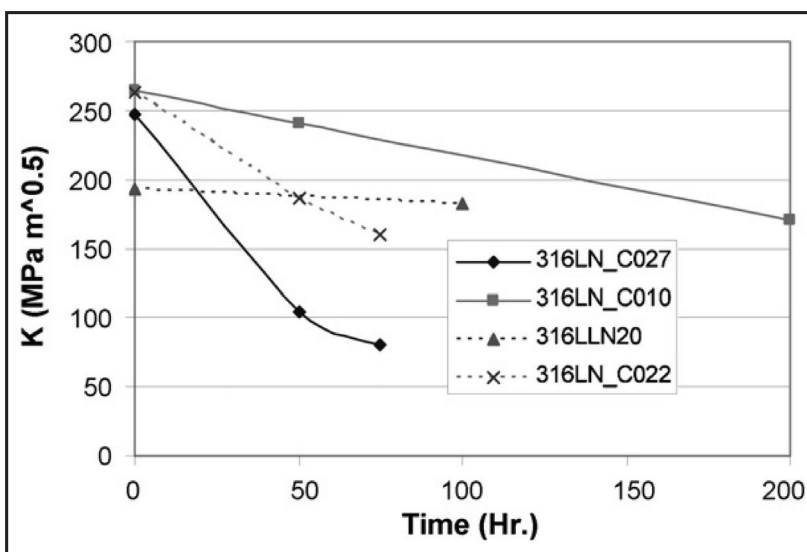

Figure 3.

The relationship between the fracture toughness/stress intensity factor and aging time of samples aged at 973K (700 °C). 316LN C10, 316LN C22, 316LN C27 are samples with carbon content 0.01, 0.022 and 0.027wt%.

Other fcc-structured high strength structural materials, such as JK2LB, were studied for replacement of the 316LN stainless steels in ITER (work supported by U.S. ITER office). The chemistry of the JK2LB sample is C: 0.025, Si: 0.41, Mn: 21.42, P: 0.02, S: 0.002, Cr: 11.93, Ni: 8.41, Mo: 0.78, N: 0.119, B: 0.0013 in weight percentage, indicating that Mn content in JK2LB is significantly higher than that in 316LN. Previous work elsewhere was undertaken mainly on the mechanical properties [K. Hamada K, *et al.*, "Optimization of JK2LB chemical composition for ITER central solenoid conduit material", *Cryogenics*, **47**:17482 (2007); H. Nakajima *et al.*, "Development of low carbon and boron added $^{22}\text{Mn}_{13}\text{Cr}_9\text{Ni}_1\text{Mo}_{0.24}\text{N}$ steel (JK2LB) for jacket which undergoes Nb_3Sn heat treatment", *IEEE Trans Appl. Supercond.*, **14**(2), 11458 (2004); J. Feng, "Fatigue life estimation for ITER CS conductor jacket by probabilistic fracture mechanics", *Fusion Eng Des*, **73**, 35773 (2005)]. At the NHMFL, the research has focused on physical properties due to the requirements of high field magnets. The measured modulus and Poisson ratio are lower than those for 316LN. The magnetization of the JB2LB has a peak at 240 K, indicating an antiferromagnetic transition with a Néel temperature $T_N = 240$ K. Below 240 K, JK2LB has antiferromagnetic ordering. In contrast, the T_N for 316LN is 25 K, significantly lower than that of JK2LB. The T_N of austenitic steels has strong correlation with their thermal expansion. Higher T_N predicts lower thermal expansion. Between 2 K and 300 K, our measured thermal expansion for JK2LB is 0.22%, appreciably lower than that of 0.33% for 316LN. The electrical resistivity, specific heat, thermal expansion, thermal conductivity and thermal diffusivity at low temperatures were also measured and published. Such an activity provides an essential database for this high strength material application in high field magnets.

High-Strength Conductors. In high strength normal conductors for resistive and pulsed magnets, we started to study the relationship among the mechanical stress, strain and electronic resistivity. All the data are monitored simultaneously in situ at cryogenic temperatures. The cyclic loading of the alumina-strengthened conductors was observed to result in a decrease of the electrical conductivity. More work is required to verify the result quantitatively.

We made further efforts in development of conductors with high densities of grain/twin boundaries or high densities of the interphase interfaces as these features increase the strength of the materials without significant reduction of their electrical conductivity. In late 2009, we have submitted a proposal to use a deposition approach to produce Cu with high densities of twins and composites with high densities of interfaces. The proposal is approved contingent to the funding. We therefore are expecting to make efforts in this area in 2010. Our efforts in understanding the deformation mechanisms in both materials pave the way for further progresses. In nanostructured CuNb, we have found local regions with large residual strain/stresses. In the same regions, non-equilibrium bcc Cu is also observed. These regions are likely the areas affecting the overall electrical resistance significantly because the electron density function will be changed in such areas. Such unique features also result in high mechanical strength that is currently utilized in various pulsed magnets. We will continue to explore further both the influence of fabrication conditions and the effects of subsequent thermal and mechanical treatments of the detailed nature of the microstructure in the Cu-Nb and other systems.

Superconducting Magnets

In 2004, COHMAG challenged the community to develop a 30 T superconducting NMR magnet. Since then there has been tremendous progress in the state of high field superconducting materials and magnet technologies. The two HTS materials that show the most promise for high field magnet development presently are YBCO and BiSSCO-2212.

YBCO Coils. The high temperature superconductor YBCO, when operated at liquid helium temperature, has very high upper critical field of 100 T or more and high current density at high field. So-called "coated conductors" of YBCO are being developed for the electric power industry in a form that also has high strength. As a result, YBCO superconductor is seen as an excellent candidate for application to very high field solenoid magnets with the potential to revolutionize the fields available in all-superconducting magnets from approximately 23 T with low temperature superconductors (LTS) to fields in excess of 30 T eventually upwards toward 50 T with YBCO. The Magnet Lab has a strong interest in developing the potential of YBCO conductors for high field magnets and has established a program of coil technology development.

A proposal was submitted in 2009 to the NSF-MRI (Major Research Instrumentation) program for a 32 T all-superconducting magnet for physics research, to be installed in the laboratory's Millikelvin User Facility in Tallahassee. The program was funded beginning October 1, 2009, for three years leading to the installation of the 32 T magnet. The magnet will consist of an inner set of YBCO coils producing a field increment of 17 T in an LTS outer magnet providing a background field of 15 T. The YBCO coils will be designed and fabricated at the NHMFL, while the LTS outer magnet will be specified and procured from industry.

A technology development program was established to support the 32 T program and to look beyond to higher fields. The program contains a number of activities including analysis, materials and component development, and small coil fabrication and test. YBCO conductor is a flat tape, as opposed to a round wire, and the conductor configuration has a strong influence on the coil winding and fabrication, including pancake and layer-wound coils. Intrinsic to YBCO as a high temperature superconductor, quench propagation rates are low, causing difficulties with quench protection. Analysis efforts have begun to address winding strains and winding methods, and to support the development of quench protection methods. There are perceived advantages to layer winding even though this entails bending the tape in the wide direction. A novel layer winding machine was designed for YBCO tape and ordered for delivery in early 2010. YBCO conductor to this point is not supplied with insulation suitable for high field magnet application. A number of routes to conductor insulation are being explored, including varnish, UV cured polymer, oxide coatings and interlayer insulations. Developmental insulation facilities have been made to support the work. The electrical and mechanical properties of joints in the conductor have been studied on tensile samples.

The technology of winding coils has been studied with the fabrication of a number of relatively large diameter thin test coils that were operated in the Large Bore Resistive Magnet at 20 T and operated to high stress and strain. These coils provided a successful demonstration that the high stress performance observed in small conductor samples can be achieved in long lengths of conductor in coil windings. Additional coils are being designed to study aspects of the technology including: joints, terminal design, quench protection, insulation methods, stress limits, and reinforcement.

BSCCO Coils. An insert magnet to reach 25 T combined field using Bi2212 round wire is one of the goals of an inter-institutional collaboration between the NHMFL and six other research laboratories in the United States. This collaboration, Very High Field Superconducting Magnet Collaboration (VHFSMC), is jointly led by the NHMFL and Fermilab and involves participation by LBNL, BNL, Texas A&M, North Carolina State U., NIST, and U.S. industry partners too. Bi2212 round wire has the huge advantage of being magnetically isotropic and can be easily adapted to a variety of applications, *e.g.* Rutherford cables. Coil manufacturing follows the wind-and-react approach, which means that all parts of the coil need to be able to withstand the high temperatures of about 900 °C, which is necessary to form an electromagnetically well-connected Bi2212 phase along the filaments. In an approach to explore the implications of Bi2212 coil processing, a series of small test coils and two larger coils were manufactured and characterized in high background fields. A cross section of the most recent coil, replicating the innermost coil of the insert magnet, is shown in **Figure 4**.

Alumino-silicate braided Bi2212 wire provided by Oxford Instruments was wound around mandrels made from a high strength, corrosion resistant Nickel-base alloy (Inconel 600). At 20 T background field this coil generated 1.2 T before the inner layer caused early quenching of the coil, see **Figure 5**. To investigate the reason for the inconsistencies in coil performance, several test coils were dissected, samples taken and characterized using magnetometry, scanning electron microscopy (SEM), and energy dispersive x-ray spectrometry (EDX). Owing to the complexity of the Bi2212 phase formation and sensitivity toward changes of heat treatment parameters and oxygen doping level the following scenarios were deemed possible: (1) a change of transport properties with the winding thickness of the coil due to reduced oxygen presence at the innermost layers yielding under-doped Bi2212 phase, (2) a gradual change of heat-treatment parameters throughout the winding pack due to the large heat capacity of the coil and coil fixture, (3) mechanical interaction between conductor and Inconel fixture as well as chemical interaction between conductor and braid insulation.

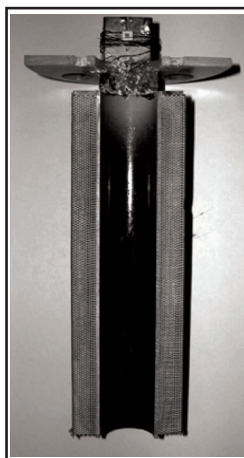

Figure 4. One of several experimental Bi2212 wire wound coils that were tested in high background field: Cross section of a 57.8 mm OD, 32.4 mm, and 180 mm high Bi2212 coil built following largely the design specification of the innermost coil of the 7 T insert magnet design.

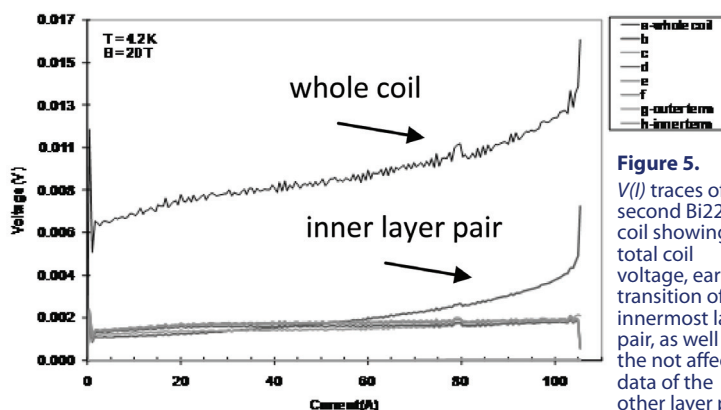

Figure 5. $V(I)$ traces of the second Bi2212 coil showing total coil voltage, early transition of the innermost layer pair, as well as the not affected data of the other layer pairs and terminals.

Short samples from various layers of this coil, as well as another 20 layer thick coil, were extracted and in-field transport properties measured. Results showed that with the exception of the inner layer coils showed homogeneous properties though generally performing below separately processed short conductor samples. SEM and EDX on samples from the innermost layers revealed two interesting phenomena: considerable deformation of the conductor, as shown in **Figure 6**, and absorption of Ag into the fibers of the braid insulation to the extent that a significant amount of the Ag-alloy matrix was being eroded away potentially generating areas through which molten components of the Bi2212 could breach the matrix as leaks. EDX showed that, in fact, Ag reacts severely with the alumino-silicate forming a brittle glass. Though the thermal expansion coefficient of the Ag-alloy and the Inconel generally match, there appears to be some other mismatch between the two materials constraining the thermal expansion of the conductor during the heat treatment, the dynamic of which is not completely understood at this point.

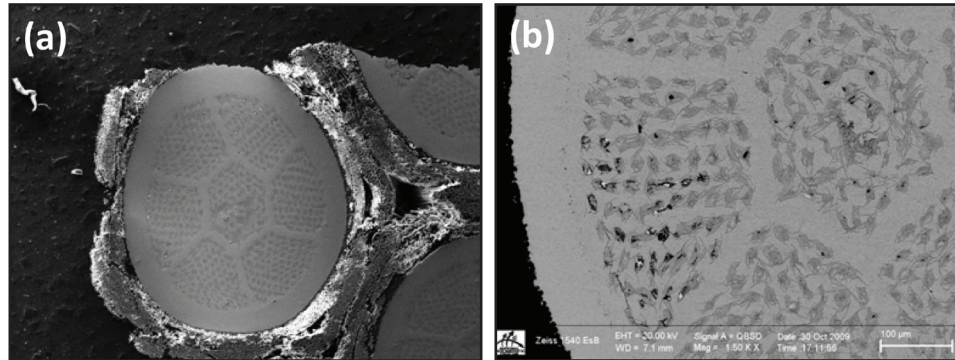

Figure 6.

(a) Transverse cross sections of a wire samples extracted from the innermost layer of the coil showing the large deformation of the wire. (b) Also, a substantial amount of voids and secondary phases is visible close to the interface between wire and Inconel coil former.

To investigate potential changes in the flux pinning properties of Bi2212 in conductor samples from the inner layers that potentially may have been caused by oxygen depletion, hysteresis and T_c measurements were carried out in a SQUID magnetometer. T_c curves as well Kramer-field extrapolations. The lack of layer dependence in the data clearly indicates no change of the flux pinning properties throughout the coil and suggests connectivity issues as a reason of reduced transport properties. This is underpinned by microstructural analyses that revealed a different type of grain growth in witness samples compared with samples extracted from coils. From systematic studies on the processing of short Bi2212 samples, we now understand that transport properties improve with the growth of large Bi2212 grains that form bridges between the filaments of the conductor [T.M. Shen *et al.*, *Supercond. Sci. Technol.*, **23**, 025009 (2010)]. While cross sections from witness samples clearly show large grain growth and substantial filament bridging, this crystallographic network is much less developed in coil samples that show a prevalence of small grain growth.

Significant improvement has occurred with Bi2212 round wire compared with Bi2212 tape conductor from a few years back. Virtually leak-free wind and react coils are now possible showing fairly consistent performance in highest fields. Due to the complexity of the Bi2212 phase formation in combination with the wind and react approach, however, there is still knowledge to be developed, which will enable us to process coils with even more consistent performance as well as higher critical current density. The existing conductor insulation has been proven problematic for two reasons: It is chemically not inert and because of its volume reduces the packing factor in coils significantly. Alternative solutions are being explored.

Superconducting Materials Development

High T_c Materials – Bi-2212. In 2009 we have focused on understanding the steps in the heat treatment process by which the round 2212 wires are made. The relation between how the microstructure and electromagnetic properties develop as 2212 forms during cooling are not well known and our through-process quench experiments have been instrumental in deconvoluting this complicated process. An important result outcome from these experiments was learning that J_c increases by at least a factor of 2 during the very last stage of the heat treatment as the wire cools to room temperature. During this cooling step, the 2212 absorbs oxygen becoming overdoped, which decreases T_c . But as Shen *et al.* showed [T.M. Shen *et al.*, *Appl. Phys. Lett.*, **95**, 152516 (2009)], this oxygen absorption increases the irreversibility field and grain connectivity, which increase J_c . This is an important finding because prior to this we had no appreciation that this cooling portion of the heat treatment was so important for controlling J_c . We can incorporate this understanding in new heat treatments to increase J_c in coils.

We had observed that the alumino-silicate insulation material that is braided around the 2212 wire reacts with the Ag sheath during the heat treatment. We also observed that J_c in coils is always ~35% lower

than in short straight samples of bare wire that receive the same heat treatment. We designed an experiment that held the braid in close contact with a short-straight section of wire during the heat treatment. We found I_c decreased by $\sim 20\%$ in those sections in contact with the insulation (**Figure 7**). EDS analysis showed Cu plus Ag in the alumino-silicate braid material. The Cu in the insulation material came from the 2212 filaments in the wire. Losing Cu from the oxide filaments during the heat treatment shifted the overall composition so it was Cu-poor in the outermost filaments in the wire. We expect that less 2212 formed in these outer filaments, which decreased J_c for the wire. We are working to understand how to prevent this J_c loss using alumino-silicate insulation and how to shift to new insulation materials that do not decrease J_c and also are thinner than the alumino-silicate braided insulation so they can increase the overall current density in the coils.

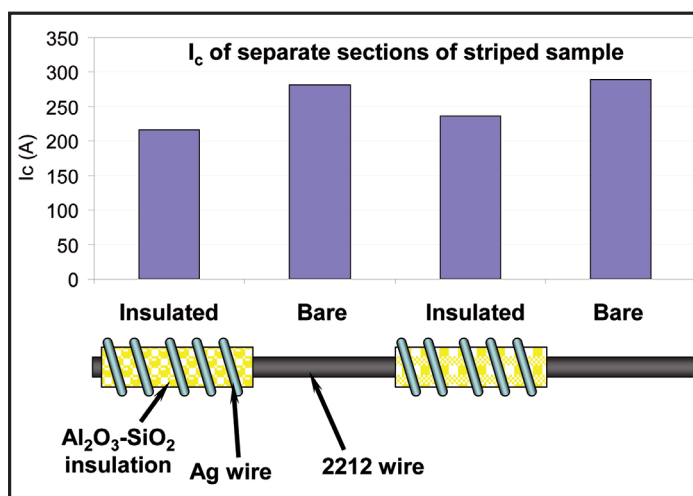

Figure 7.

Experimental design to isolate the effect of the braided alumino-silicate insulation on I_c in 2212 wire. J_c is $\sim 20\%$ lower in the insulated sections of the wire.

In 2009 we received funding from DOE-HEP, which is now supporting a highly interactive six-laboratory (FNAL, BNL, LBNL, TAMU, NIST, and NHMFL) effort to develop 2212 coils for very high field, ≥ 30 T applications. This fulfills an important goal of COHMAG, namely to forge a multi-sector, multi-lab effort to develop very high field magnet technology based on HTS conductor technology.

High T_c Materials – YBCO. Further development of growth YBCO by *ex situ* method using F-free techniques revealed that the optimum BZO content is ~ 5 vol%. It appears to be possible to use 3 layers in process of precursor deposition, which increase the pinning force (F_p) up to 6.5 GN/m^3 for 800 nm thick film. The microstructure is far from perfect however therefore true F_{pmax} might be 3 times higher. Stable BZO pinning centers seem to form during the heat treatment. The F_p and J_c reach maximums as the heat treatment time approaches optimum 90 min. Change of YBCO properties at times longer than the optimum seems to be due to poisoning by the substrate.

During 2009 we continued experiments on YBCO single grain boundaries in the frame of an AMSC-led Wire Development Group collaboration. To understand which type of grain boundary is better at carrying supercurrent in YBCO CC, we used the synergy of Low Temperature Scanning Laser Microscope (LTLSTM), Focused Ion Beam (FIB), and Orientation Imaging Microscopy (OIM). This issue becomes important after recent experiments by Held *et al.* [R. Held *et al.*, "Low-angle grain boundaries in $\text{YBa}_2\text{Cu}_3\text{O}_{7-\delta}$ with high critical current densities", *Phys. Rev. B*, **79**, 014515 (2009)] on YBCO grain boundary (GB) grown on bicrystal substrates. They have proposed that [010]-tilt GBs, which is GBs with an out-of-plane tilt, have significantly higher grain boundary J_c than in-plane tilted GBs of similar disorientation.

Since neighboring grains in YBCO CC usually do not share a simple low-index common axis, calculation of dominant misorientation component is not straight forward. Commercially available software does not separate the GBs by types; therefore we developed a new procedure to separate in-plane (IP) and out-of-plane (OOP) misorientations of GBs using OIM Euler angle data arrays obtained with EDAX system. The IP misorientation angle is calculated by separating Rodriguez vectors. The angle between c-axes of neighboring grains we define as OOP misorientation.

We have chosen two YBCO films with plane GBs to avoid difficulties of interpretation connected with meandering effects. One film was deposited on modern AMSC RABiTS by *in situ* PLD method in NHMFL. The second film was deposited on less textured AMSC RABiTS by *ex situ* method in ORNL. Very narrow (≈ 5 μm wide) 1D links with smooth edges were patterned with FIB. The local electric field maps of 1D links were detected with LTLSTM at gradually increased bias currents (I_{bias}) and magnetic fields up to 5 T oriented perpendicular to the sample plane. The I_c is defined at onset of the local electric field. Then the transport data were combined with OIM results to get a dependence of the critical current density on IP and OOP misorientation angles, which is 2D version of Demos dependence.

We found that all of the 50 naturally occurring GBs that affect local dissipation displayed mixed IP and OOP misorientations. For the CC grown on improved RABiTS, the OOP GB map was fragmented and not a continuous network as it was for YBCO grown on older RABiTS. IP and OOP misorientation components of older RABiTS reduce J_c similarly. On more modern RABiTS, OOP component reduces J_c more than IP component. 1D links of about 5 micron width produce large degradation of J_c due to limitation by the lowest J_c GB, which limits filamentization possibilities.

High T_c Materials – Pnictides. We continued working on the fascinating electromagnetic properties of the recently discovered ferropnictide superconductors which many regard as promising future materials for high field magnet applications [M. Putti *et al.*, *Superconductor Science and Technology* (2009) (to appear) arXiv: 0910.1297]. We have performed

transport measurements of different oxypnictides at high magnetic fields (dc up to 45T and pulsed up to 60T) to determine the upper critical field, the irreversibility field and the critical currents – the main parameters for power applications [A. Yamamoto *et al.*, *Appl. Phys. Lett.*, **94**, 062511 (2009); Y.J. Jo, *et al.*, *Physica C*, **469**, 566-574 (2009); F. Kametani, *et al.*, *Appl. Phys. Lett.*, **95**, 142502 (2009)]. In particular, we addressed the key question of whether the grain boundaries in pnictides are transparent to current. In collaboration with the group of C.B. Eom at the University of Wisconsin, we performed for the first time transport, magneto-optical, and LTLSM measurements of critical currents across grain boundaries in $\text{Ba}(\text{Fe}_x\text{Co}_{1-x})\text{Fe}_2\text{As}_2$ epitaxial thin film bicrystals. See **Figure 8**. Our results have unambiguously demonstrated that low angle grain boundaries in pnictides are significant obstacles to current and behave rather similarly to the grain boundaries in high- T_c cuprates [S. Lee *et al.*, *Appl. Phys. Lett.*, **95**, 212505 (2009)].

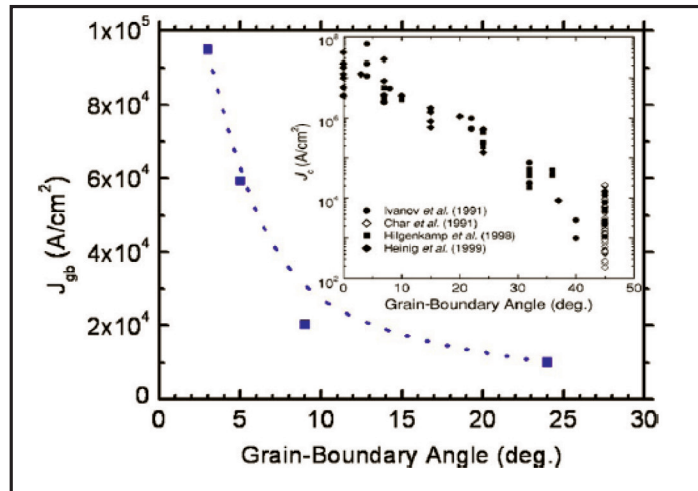

Figure 8.

Critical current as a function of misorientation angle in $\text{Ba}(\text{Fe}_x\text{Co}_{1-x})\text{Fe}_2\text{As}_2$ thin film bicrystals. The insert shows the similar exponential decrease of $J_c(\theta)$ in YBCO

We performed the first experiment on the effect of magnetic and nonmagnetic disorder induced by a particle irradiation on the critical temperature of a $\text{NdFeAsO}_{0.7}\text{F}_{0.3}$ single crystal (Nd-1111) from Beijing CAS group by Hai-Hu Wen. Irradiation was carried out at 300K using a 2 MeV $^4\text{He}^{2+}$ ion beam from a Tandem accelerator at Arizona State University in the group of Prof. Nate Newman. The striking results of these experiments [C. Tarantini *et al.*, *Phys. Rev. Lett.* (2009) (submitted)] can be summarized as follows: (1) Irradiation results in a strong resistivity upturn and the logarithmic temperature dependence of excess resistivity indicative of the spin-flip Kondo scattering induced by irradiation defects. (2) The excess resistivity has both magnetic and nonmagnetic contributions, indicating that the displacements of Fe or As ions by the α particles produced irradiation defects, which have both nonmagnetic and spin-flip scattering potential. (3) The observed suppression of T_c by irradiation defects is much weaker than what is predicted by the existing theories, despite the fact that irradiation produces strong magnetic and nonmagnetic scattering by point defects spaced by only 1-2 nm. (4) The remarkable resilience of ferropnictides to magnetic and nonmagnetic disorder observed in our work should be very beneficial for applications.

Low T_c Materials – Nb for Superconductivity Radio Frequency (SRF) Cavity Accelerators. Work at the Applied Superconductivity Center, then at the University of Wisconsin-Madison, sprang out of a request from Fermilab to help nucleate a regional effort around Wisconsin, Chicago, and Michigan State. It has continued to this date after the move to FSU. With Fermilab now leading the effort in a very interactive way, these efforts and funding actions have strengthened with major additional support from DOE via Fermilab and from Argonne National Laboratory (ANL). Our transport critical-current studies of the Nb bicrystals have found direct evidence for early flux flow consistent with our earlier magneto-optical imaging studies and our interpretation that early GB flux penetration is one cause of early RF cavity quench.

We continue working on the key issues that determine the fundamental performance limits of Nb cavities for particle accelerators. Under two new DOE grants we have been able to collaborate with groups at ANL and FermiLab on the enhancement of the SRF performance of Nb cavities by ALD multilayer coating (ANL) and on studies of surface defects in Nb cavities (FermiLab). In particular, we were developing theories

of the nonlinear surface resistance in a thin film, which is the key component of the multilayer coating of Nb cavities suggested in our previous work. In collaboration with the FSU group of I. Chiorescu we addressed the issue of the nonlinear Meissner effect in dirty Nb films in rf electromagnetic fields. We proposed a new technique of nonlinear Meissner spectroscopy that has enabled us for the first time to observe the nonlinear Meissner effect in superconductors under true equilibrium conditions. We developed a theory of this effect which shows that the reactance of the film depends quadratically on the applied parallel magnetic field and exhibits a $2\text{-cos}2\alpha$ dependence on the angle α between the film and the field direction. The theory is in excellent agreement with the experimental data [N. Groll *et al.*, *Phys. Rev. B*, **81** (Rapid Comm.), 020504 (2010)].

LTS Materials – Nb₃Sn. Our work has been central to the large increase of J_c that has occurred within the HEP-driven (High Energy Physics) program. The Applied Superconductivity Center (ASC) at the NMFLL plays a leading role in the DOE-funded Conductor Development Program (CDP) that funds industrial R&D and coordinates the national effort. In 2009 DOE renewed our core effort on development of high- J_c Nb₃Sn strand, and we also saw this supplemented by direct support from the Brookhaven National Laboratory (BNL) magnet development program, which is interested in precise measurement of microstructural features in a variety of alloyed composites. A new 3-year study of Nb₃Sn strand for the ITER strand procurement program is supported by ITER-IO, Cadarache, France. Our work is part of a multi-university effort in Europe and in December we hosted a PhD student from the Ecole Centrale Polytechnique in Paris who came to the Magnet Lab to use our metallographic characterization capabilities to provide a direct test of his cable modeling software. As might have been predicted, reality is more complex than the model. Indeed, there have been several important discoveries thanks to the ability we have developed to make high quality metallography cross-section of full-sized conductor cross-sections: In **Figure 9** we show a variety of serious strand defects in ITER TFMC-FSJS conductor that show significant performance degradation as tested in SULTAN. This study has shown how important it is to know both the macro- and the micro-microstructural quality of the strand before and after cabling. Our metallographic post-mortem study of strain-tested strands for ITER in collaboration with the University of Twente has continued, as has the parallel DOE-HEP supported collaboration with NIST in Boulder for HEP strands. We reported the results of our successful collaboration with FermiLab to study cabling damage using our combined metallographic and magneto optical capabilities, and it was chosen for the cover and as the feature article in *Superconducting Science and Technology* [A.A. Polyanskii *et al.*, "Evidence for highly localized damage in internal tin and powder-in-tube Nb₃Sn strands rolled before reaction obtained from coupled magneto-optical imaging and confocal laser scanning microscopy", *Superconductor Science and Technology*, **22** (9), 095008 (13pp) (2009)]. An expansion of this work is expected in 2010.

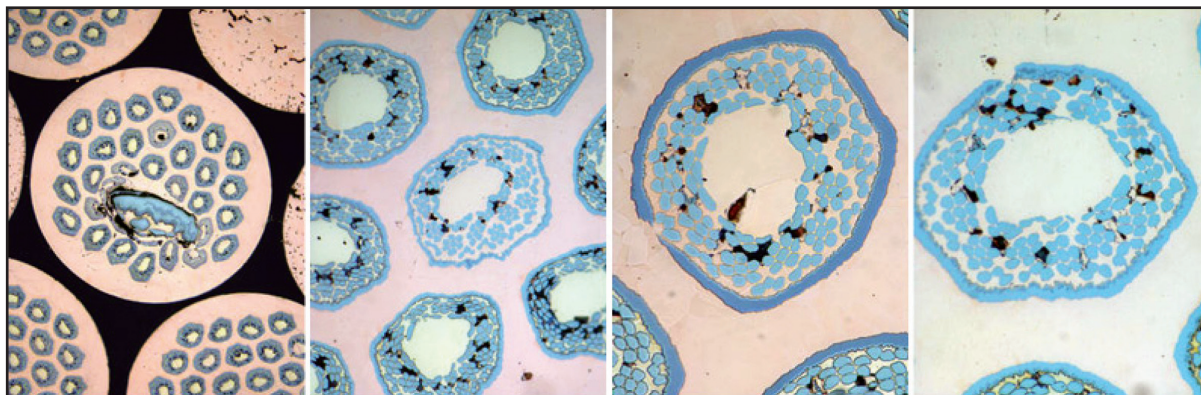

Figure 9
Light microscope images of defects in strand inside the ITER TFMC-FSJS.

At the individual filament level we have been seeking to understand the compositional variation of H_{c2} so that we can model filaments as shells of varying Sn content and we have obtained the very unexpected result that a pure binary A15 (i.e. Nb-Sn without Cu) does *not* have a suppressed H_{c2} when tetragonal and that the high value of $H_{c2}(0)$ in the binary system at 29.5 T is almost identical to that produced in the Cu-containing chemistry of wires only when the A15 phase is alloyed with Ti or Ta.

We also undertook research on the stress-strain impact on the physical properties of various conductors, particularly Nb₃Sn in axial tension and compression as well as transverse compression. The sensitivity to transverse stress is a particularly critical concern in the degradation of CICC's. **Figure 10** is a plot of the critical current, J_c and n value as functions of transverse stress. It is noted that there is an initial subtle

increase in J_c with transverse compression below 30 MPa. This may be interpreted by the reduction of initial deviatoric thermal strain under the transverse compressive strain. It is noted, however, that this behavior has not been observed in a similar strand tested under periodic contact stress. It is observed that there is a rapid decrease in the value under stresses less than 10 MPa.

An important component of our low- T_c work is encouraging laboratory-university-industry collaboration via the annual Low Temperature Superconductor Workshop, which again was jointly organized by LBNL and ASC. The recent advances in HTS materials for generation of very high fields caused great interest too and a broadening of the agenda. This aspect was a particularly strong component of the 14th US-Japan Workshop on Advanced Superconductors that attracted over 65 participants to Tallahassee in December 2009.

CICC Magnets

There are presently three large-scale magnet projects using Cable-In-Conduit Conductor (CICC) underway at the NHMFL. The two that are under construction utilize a CICC “outsert” coil electrically in series with a resistive “insert” to form a Series-Connected Hybrid (SCH) magnet. Of them, one is a SCH funded by the NSF that is to be located at the NHMFL. It is a 36 T, high homogeneity magnet at 1 ppm uniformity in a 40 mm cylindrical warm bore for NMR and general research. The other is funded by the German government for the Helmholtz Zentrum Berlin (HZB). It is a 25 T magnet with a conical bore in a horizontal orientation for neutron scattering experiments. The third magnet system is for the Spallation Neutron Source at ORNL and will combine a CICC outsert with an insert made of YBCO, for an all-superconducting system. This has been the subject of a conceptual engineering design phase (CED) funded by the NSF. In July 2009 a proposal was submitted to NSF for construction of the magnet. A proposal will be submitted in early 2010 to DOE for construction of the beamline, detectors, and other infrastructure.

Series Connected Hybrids (SCHs) for HZB and NHMFL. A significant amount of progress has been achieved toward the construction of the SCHs for the HZB and the NHMFL. The systems have the same outsert designs and are similar in concept; however the differences in the insert coils and cryostat orientation require separate designs for many of the subsystems.

The HZB and NHMFL both will use a helium refrigerator to flow and recycle helium through the CICC coils. The specifications for refrigerators and distribution boxes at both sites have been completed and the procurement has begun with a call for tender by both institutions.

A full analysis and design package on the cryostat for the HZB system has been completed and its procurement has begun. **Figure 11** shows the assembled cryostat. The horizontal orientation of the HZB cryostat led to the placement of the HTS leads at the top. This keeps a compact design that is also balanced—a necessary requirement to achieve the $\pm 15^\circ$ rotation specification. The manufacturing design package for the NHMFL cryostat has begun. Its cryostat design has also matured to a more compact configuration as shown in **Figure 12**. The HTS hybrid leads are now located in the same vessel as the magnet. This reduces the number of parts to manufacture and greatly simplifies the routing of the large bus lines during assembly.

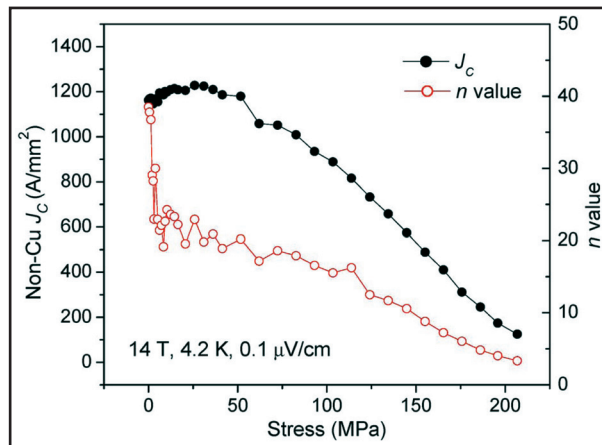

Figure 10.

J_c and n values of the Nb_3Sn type superconductor composite under transverse compressive stress. The solid lines are guides to the eye.

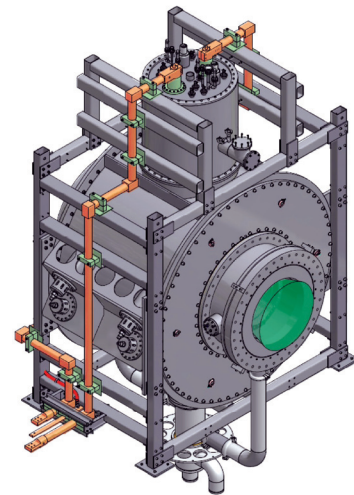

Figure 11.

Cryostat for the HZB SCH.

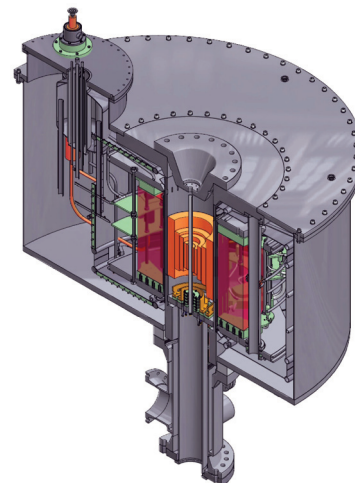

Figure 12.

Cryostat for the NHMFL SCH.

Approximately 90% of the Nb_3Sn strand for HZB has been manufactured by Oxford Superconducting Technologies and delivered. The remainder and the strand for the NHMFL are expected in March of 2010, ahead of schedule. After the strand is manufactured, it is formed into a multistage cable by New England Wire Technologies. Two of the ten superconducting cables have been completed thus far.

The NHMFL has contracted with an Italian cryogenic systems manufacturer, Criotec Impianti, to jacket the cables that form the CICC. They will be partnering with an Italian research organization, ENEA, to complete this contract. For this, a 600+ m long length jacketing line is being set up at the Criotec facility where the superconducting cables will be pulled into a long weldment of stainless steel tubing and subsequently compacted to a smaller and rectangular cross-section. In 2009 as part of qualification of the line, three prototype CICC's were manufactured using copper cables to represent the three CICC types used in the outsert coils. **Figure 13** shows the completed prototype CICC.

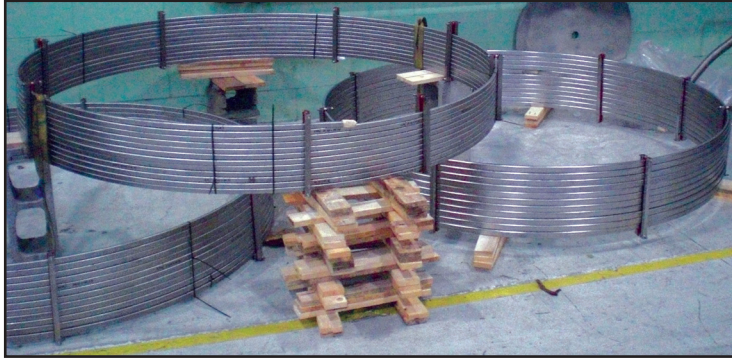

Figure 13.
Completed prototype CICC.

Many other milestones were achieved in 2009, principally (1) commencement of the fabrication of 4 kA prototype HTS binary leads, (2) fabrication of the Nb-Ti cable for the bus line that connects the outsert coil to the HTS leads, (3) development and testing of the superconducting joint between the Nb_3Sn outsert coil to the Nb-Ti bus line, and (4) completion of the CICC coil fabrication hardware design package.

SC Magnet for SNS. Unlike the other CICC magnets, the “Zeemans” magnet is designed to produce a field of 30 T on axis using all superconducting coils. The use of a superconducting insert rather than resistive insert significantly reduces the capital costs required for the power supplies and chilled water systems and reduces the operational costs. The magnet warm bore is defined by a central cylindrical region of 50 mm diameter and 62 mm length, which opens into a conical shape toward both ends of the warm bore with a cone-angle of 15° from the central axis.

The magnet consists of a Nb_3Sn CICC outsert magnet giving a field of 13 T, and an adiabatically stable inner magnet containing YBCO and Nb_3Sn coils providing a field of 17 T. The magnet is shielded to cancel the dipole moment using separate shield coils for the inner and outer magnets. The outer magnet shield coil is a CICC coil using NbTi conductor, while the inner magnet shield coil is wound over the outer magnet shield coil as a single layer of NbTi wire. The field uniformity of the combined magnet is better than 0.2% in a central region of diameter 20 mm and length 20 mm. The magnet is contained in a horizontal warm bore cryostat shown in **Figure 14**.

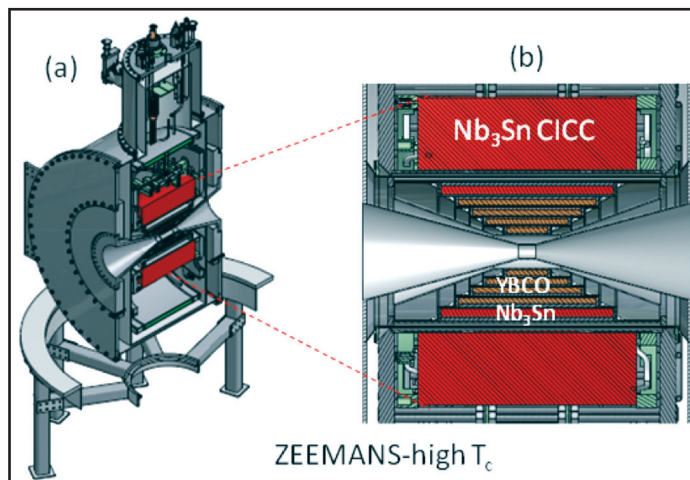

Figure 14.
Zeemans SCH magnet configuration.

Chapter 5: User Collaboration Grants Program

The National Science Foundation charged the National High Magnetic Field Laboratory (NHMFL) with developing an internal grants program that utilizes the NHMFL facilities to carry out high quality research at the forefront of science and engineering and advances the facilities and their scientific and technical capabilities. The User Collaboration Grants Program (UCGP) established in 1996 stimulates magnet and facility development and provides intellectual leadership for experimental and theoretical research in magnetic materials and phenomena.

The UCGP seeks to achieve these objectives by funding research projects of normally one- to two-year duration in the following categories:

- small, seeded collaborations between internal and/or external investigators that utilize their complementary expertise;
- bold but risky efforts that hold significant potential to extend the range and type of experiments; and
- seed support for new faculty and research staff, targeted to magnet laboratory enhancements.

The UCGP strongly encourages collaboration across host-institutional boundaries; between internal and external investigators in academia, national laboratories and industry; and interaction between theory and experiment. Some projects are also supported to drive new or unique research, that is, to serve as seed money to develop initial data leading to external funding of a larger program. In accord with NSF policies, the NHMFL cannot fund clinical studies.

Fourteen (14) UCGP solicitations have now been completed with a total of 437 pre-proposals being submitted for review. Of the 437 proposals, 219 were selected to advance to the second phase of review, and 95 were funded (21.74% of the total number of submitted proposals).

2009 Solicitation and Awards

The NHMFL UCGP has been highly successful as a mechanism for supporting outstanding projects in the various areas of research pursued at the laboratory. Since 2001, submission and proposal review (including two review stages) have been conducted and managed by a web-based system.

Of the 23 pre-proposals received, the committee recommended that 13 pre-proposals be moved to the full proposal stage. Of the 13 full proposals, 5 grants were awarded. A breakdown of the review results is presented in the **Tables 1 and 2**.

Table 1. UCGP Proposal Solicitation Results 2009

Research Area	Pre-Proposals Submitted	Pre-Proposals Proceeding to Full Proposal	Projects Funded
Condensed Matter Science	14	6	2
Biological & Chemical Sciences	7	6	2
Magnet & Magnet Materials Technology	2	1	1
Total	23	13	5

Table 2. UCGP Funded Projects from 2009 Solicitation

Lead P.I.	NHMFL Institution	Project Title	Funding
Stephen McGill	FSU	Raman Spectroscopy of Low-Dimensional Spin Systems	\$225,122
Riqiang Fu	FSU	In Situ Electrochemical-NMR Spectroscopy of Lithium Rechargeable Batteries	\$187,864
Stephen Blackband	UF	MR Microscopy at the Cellular Level Using Microsurface RF Coils	\$184,060
Ke Han	FSU	Twin Boundary and Interface Strengthened Conductors	\$189,392
Eric Palm	FSU	Thermal Expansion and Magnetostriction at the NHMFL	\$207,491

2010 Solicitation

The 2010 Solicitation Announcement will be released about April 19, 2010. Awards will be announced by the end of the year.

Results Reporting

To assess the success of the UCGP, reports were requested in February 2010, on grants issued from the solicitations held in the years 2004 through 2008, which had start dates respectively near the beginnings of years 2005 through 2009. At the time of the reporting, some of these grants were in progress, and some had been completed. For this "retrospective" reporting, PIs were asked to include external grants, NHMFL facilities enhancements, and publications that were generated by the UCGP. Since UCGP grants are intended to seed new research through high risk initial study or facility enhancements, PIs were allowed and encouraged to report results that their UCGP grant had made possible, even if these were obtained after the term of the UCGP grant was complete.

Tables 3 and 4 summarize the results. The success of the program is evident from the wide-ranging enhancements produced and from the production of peer-reviewed publications, many in high impact journals. These include 3 articles in *Nature*, 16 in *Physical Review Letters*, and 6 in the *Journal of the American Chemical Society*. A significant positive impact on education is also evident from the reporting, since almost all grants were reported to have supported one or more students, at least partially or through supplies.

Table 3. Facility Enhancements Reported from 2004-2008 UCGP Solicitations

Enhancement and available date	Users*
Silicon micromechanical Faraday balance for absolute magnetization measurements, 1/06	3
OPO laser for IR spectroscopy in conjunction with ICR, 1/07	3
Temperature control of ³ He rotator probe for superconductor measurements, 12/06	8
Time-resolved reflection, photoluminescence and Kerr effect spectroscopy, in 17 T and 31 T magnets, 10/07	6
Time domain spectroscopy 200 GHz- 1 THz, 5/09	2
Photoluminescence probe with fiber-free light retrieval, 1/09	1
AFM cantilever tip as the active element in a dilatometer, 9/09	2
Thermal conductivity and specific heat measurements for high fields, 1/05	16
Rotator to perform pulsed critical currents measurements at different temperatures, 4 /09	1
Low temperature HEMT based NMR preamp, for High B/T facility, 5/08	1
Mössbauer facility, 2/07	2
Probe and coils for in vivo NMR with 900 MHz and 600 MHz magnets, 1/09	3
900 MHz high B1 homogeneity dielectric resonator for NMR, 5/09	1
Triple resonance 600 MHz "low E" probe, 3/10	1
Double resonance low E magic angle spinning probe for 750 MHz biological solid state NMR, 12/08	2
High resolution visible spectrometer with LN ₂ -cooled CCD, 7/09	1
Microscope-based setup for room temperature Raman spectroscopy, 8/09	1

*Number of external users (PIs only) reported to have used the enhancements.

Table 4. New Publications Reported, 2004-2008 UCGP Solicitations

App. Phys. Lett.	5
J. Applied Phys. Lett.	3
Adv. in Cryogenic Engineering	1
Biochemistry	2
Inorg. Biochem.	1
Inorg. Chem.	3
Inst. of Phys. – Conf. Series	2
J. Alloy Compd.	1
Ultrafast Phenomena	1
Int. J. of Modern Phys.	2
J. Biomol. NMR	1
J. Mod. Optics	1
J. Phys. Cond. Mat.	4
J. of Magnetic Resonance	2
Solid State NMR	1
Magnetic Reson. Chem.	1
J. of Physical Chemistry	2
J. of American Chem. Society	7
Nature Materials	1
Nature	3
Science & Technology	3
Physica B	1
Physica C	2
Phys. Rev. B	25
Phys. Rev. Lett.	16
Polyhedron	1
Conference Proc.	8

Publications (including accepted for publication) as of December 2009, reported from UCGP grants

Chapter 6: Education

Introduction

The Magnet Lab's commitment to fostering the next generation of scientists and engineers ensures that staff from the **Center for Integrating Research & Learning** (CIRL) is fully committed each day to activities that support this mission. Programs that focus on K12 students, undergraduates, graduate students, parents, teachers, and the general public (see <http://magnet.fsu.edu/education>) are diverse and include signature programs – REU and RET – and evolving programs, like After-School Workshops for Teachers. Some programs target specific underserved populations – SciGirls – and other programs are designed for a wider audience, like Doing Science Together and Outreach. CIRL as an organization is fully engaged in providing quality programming and materials designed to excite and educate. A renewed national commitment to science, technology, engineering, and mathematics education ensures a place for the Magnet Lab to play an important role in improving and enhancing informal science education.

Research Experiences for Undergraduates

The 2009 REU program hosted 21 undergraduate students from 13 different colleges and universities around the United States. The program's support and success stems from the 20 different mentors who worked with participants to provide a quality learning experience. The students worked on projects ranging from fluorescent protein imaging with Michael Davidson to the Evaluation of Lithium Niobium Oxide/ Germanium using Resonant Ultrasound Spectroscopy with Alexey Souslov.



Jessica Sasser, FSU student, in Geochemistry.



Blessing Ogbemudia, in Mike Davidson's lab.

Students also participated in activities that took them out of their laboratories to seminars and lectures, as well as to social events such as mountain biking and trips to local attractions. The REU poster session at the end of the 6-week experience included two (**Jay Goddard** and **Jessica Sasser**) that went on to represent the program at the university-wide celebration of undergraduate research.

Research Experiences for Undergraduates - 2009 Participants

REU Participant	School	Research Area	Mentor
Daniel Brown	Wabash College	Magnetization in Materials Using a Magneto-Optical Kerr Effect Probe	Stephen McGill (FSU site)
Alicia Calero	Florida State University	Monitored Dynamics of the Self-Assembled Peptide RADA16I Nanofiber Scaffold	Ongi Englander (FSU site)
Sylvia Carroll	University of Texas, El Paso	Magnetization Measurements of Organo-Metallic Quantum Magnets	Ross McDonald (LANL site)
Kayla Crosbie	University of Colorado	Elastic Modulus Evaluation of a LiNbO ₃ /Ge Sandwich by Resonant Ultrasound Spectroscopy	Alexey Souslov (FSU site)
Ali Darkazalli	Florida State University	<i>Ex vivo</i> MRI of Neuronal Progenitor Cells in the Subventricular Zone of the Lateral Ventricle	Sam Grant (FSU site)
Connor Eck	Northwestern University	Experimental Setup for Giant Magnetoresistance (GMR) Studies in Ferro/Normal Multilayers	Irinel Chiorescu (FSU site)
Jim Ervil	Florida State University	<i>In Vivo</i> MRI Rodent Cancer Therapy	Victor Schepkin (FSU site)
Bill Garcia	Florida State University	Exploring the Use of Permanent Magnets for Magnetic Resonance Imaging	Arneil Reyes (FSU site)
Jay Goddard	Florida State University	Separation of Metal Binding Ligands from Dissolved Organic Matter	Vincent Salters (FSU site)
Shamika Green	Norfolk State University	Nitrogen Gas Storage in a Zeolite	Neil Sullivan (UF site)
Mary Gurak	University of Texas, Dallas	Electron Paramagnetic Resonance Experiments on Frustrated Organo-metallic Materials	Vivien Zapf (LANL site)
August Larson	Florida State University	Crystallinity and Dielectric Response in SWNT-Thermoplastic Composites	Jim Brooks (FSU site)
Cory McLaughlin	Florida State University	Synthesis and Characterization of the Alzheimer's β -amyloid Protein	Anant Paravastu (FSU site)
David McPherson	University of Texas, El Paso	Femtosecond Electron Diffraction and Shadow Imaging	Jim Cao (FSU site)
Blessing Ogbemudia	Ohio State University	Painting the Focal Adhesion: Fluorescent Protein Vinculin Fusions	Mike Davidson (FSU site)
Jonathan Padelford	Columbus State University	Electrodeposition of Cu and Cu/Cr Multilayers	Ke Han (FSU site)
Richard Pardilla	Loyola University Chicago	N-Terminus of Pulmonary Surfactant Protein B: Peptide Synthesis and Spectroscopy	Joanna Long (UF site)
Jessica Sasser	Florida State University	Separation of Metal Binding Ligands from Dissolved Organic Matter	Vincent Salters (FSU site)
Corrie Tate Smith	Occidental College	GHz Transmission and Dielectric Resonant Structures for Use in Ultra-high Magnetic Fields	Chuck Mielke (LANL site)
Pedro Vargas	University of Puerto Rico	Reducing Porosity on Bi-2212 Wire	Eric Hellstrom (FSU site)
Nicole Walsh	Tallahassee Community College	Heat Treatment of Internal-Sn Nb ₃ Sn Wires	Peter Lee (FSU site)

Brandon Nzekwe, Graduate Research Assistant, continued REU tracking and data analysis through 2009 to include 10 years' data from 197 participants: 72.6% of participants were located at FSU, 14.2% at LANL, and 13.2% at UF. Of the 197 participants, 47.7% are full-time students; 19.8% have publications, and 10.7% have publications with NHMFL mentors. Forty-two percent of 191 students who identified their college majors were majoring in a physics discipline; 34.0% were majoring in engineering disciplines; 17.3% in chemistry disciplines; 15.7% in the life sciences; and 10.7% in mathematics (some students had dual majors and some majors are categorized in two disciplines). Future directions for the REU research include comparison of REU participants across programs. Clarke Atlanta University, University of South Florida, Duke University, University of Arizona, and University of Maine have agreed to participate in the comparative study in 2010.

Research Experiences for Teachers

The 2009 RET program, conducted at NHMFL-FSU, hosted 13 teachers from 9 counties from South Florida to Northern Utah. The 2009 RET program's success was in large part due to the wonderful and diverse mentors who provided the research opportunity for the teachers. This year's mentors included NHMFL scientists from physics, biomedical engineering, and geochemistry, as well as from the Applied Superconductivity Center. Teachers ranging from elementary (5), middle (4), and high school (4) were able to complete 6 weeks of research coupled with daily colloquia to enhance their teaching and learning experience at the Magnet Lab. Research completed by the teachers ranged from the study of the Azores volcanic rocks to the synthesis of nanowires; results were presented at a public poster session.



2009 RET participants with **Jose Sanchez**, CIRL Assistant Director (left)

Research Experiences for Teachers - 2009 Participants

RET Participant	Home Town	Research Area	Mentor
Charles Carpenter	Tallahassee, FL	Scientific Investigation into Magma Sources of the Azores Volcanic Rocks	Munir Humayun
Glenda Castillo	Davenport, FL	Understanding the Progression of Alkaline Earth Cuprate and Copper Free Phase through Partial-Melt Processing of New Generation, Multifilamentary Round Wire Bi-2212	Eric Hellstrom
John Clark	Deland, FL	Temperature Dependence of Electron-Phonon Coupling and its Correlation to Ultra Fast Demagnetization	Jim Cao
David d'Albany	Tampa, FL	Scientific Investigation into Magma Sources of the Azores Volcanic Rocks	Munir Humayun
Mohamed Elgazzar	Orlando, FL	Experimental Setup for Giant Magnetoresistance (GMR) Studies in Ferro/Normal Multilayers	Irinel Chiorescu
Christina Henderson	Woodville, FL	Nanowire Synthesis	Ongi Englander
Terry King	Tallahassee, FL	Reaction Comparison of Superconducting Wires Using Image Analysis of High Resolution Micrograph	Bob Goddard
Gwendolyn Patrick	Clewiston, FL	Solid State NMR Investigation of Oligomers and Monomers of the Amyloid- β Protein of Alzheimer's Disease	Anant Paravastu
Miranda Rehberg	Altha, FL	Reaction Comparison of Superconducting Wires Using Image Analysis of High Resolution Micrograph	Bob Goddard
Anicia Robinson	Tallahassee, FL	Levitation of Pyrolytic Graphite and Neodymium Magnets through the Utilization of Magnetic and Electromagnetic Fields	Alexey Souslov
Christina Sanchez	Kearns, UT	Understanding the Progression of Alkaline Earth Cuprate and Copper Free Phase through Partial-Melt Processing of New Generation, Multifilamentary Round Wire Bi-2212	Eric Hellstrom
Jennifer Suarez	Tallahassee, FL	Nanowire Synthesis	Anant Paravastu
Bryan Wilkinson	Tallahassee, FL	Levitation of Pyrolytic Graphite and Neodymium Magnets through the Utilization of Magnetic and Electromagnetic Fields	Alexey Souslov

Roxanne Hughes, Graduate Research Assistant, continued research on the RET program and past participants and expanded the research to include the effect of mentors on teachers' instruction and views of science. Research indicates that teachers form a better understanding of the process of science and a better understanding of the importance of communicating in science. CIRL maintains contact with many former RET participants and is a resource for materials, assistance with classroom activities, science fair judging, mentoring students, and conducting professional development in schools.



Anant Paravastu mentors **Jennifer Suarez**, middle school teacher, and **Gwendolyn Patrick**, elementary school teacher.

Outreach

"Traditional" outreach was provided to 8,104 K12 students in 2009: 7,155 in classroom visits and 949 who visited the Magnet Lab in Tallahassee from 6 Florida counties: Calhoun, Columbia, Decatur, Leon, Thomas, and Wakulla. Nontraditional outreach—school science nights, Doing Science Together at Barnes & Noble, Family Science Night at Chick-fil-A—accounted for 750 students and parents. Thirty-five tours were conducted for 630 visitors, *not including* the approximately 5,000 visitors who toured the lab during the 2009 Annual Open House. **Carlos Villa**, Outreach Coordinator, organizes and facilitates K12 outreach, as well as the middle school mentorship program each spring.

An online outreach request system was initiated in fall 2009. In conjunction, an online form was developed for reporting tours and community outreach in order to capture the number of visitors to the lab and number of students, parents, and the general public to whom outreach was provided. These efforts streamlined the procedure for teachers and allowed lab staff access to the system to record outreach efforts, resulting in more accurate accounting. Outreach activities are dynamically announced on the Web site and on a monitor in the NHMFL lobby.

In an effort to extend outreach to parents as well as students, **Jose Sanchez**, CIRL's Assistant Director, conducted a workshop in Spanish for a local Title I elementary school. Pineview Elementary school is the lab's neighborhood school with a significant Spanish-speaking population. At their request, the Magnet Lab hosted a science fair workshop to help parents provide assistance to their children at home. A great success, we are looking at ways to further engage parents in helping their children get the most out of formal science instruction.



SciGirls



SciGirls, a 2-week science camp for middle and high school girls, completed its fourth year in 2009. Thirty-three girls experienced science careers firsthand at NHMFL, FSU, the FAMU-FSU College of Engineering, and area laboratories, including working at a construction site with local engineers. Through diverse hands-on activities, the girls expanded their understanding of real-world science and had the opportunity to work with world class scientists and engineers. For the first time, we made the decision to find ways to keep the girls involved throughout the school year. In fall 2009, SciGirls received a

grant from the City of Tallahassee to plant a rain garden at the Magnet Lab to handle storm water run-off. In addition, participants assisted at the Magnet Lab Open House, Magnet Mystery Hour Family Night, several area school science nights, and other community events. **Kristen Molyneaux** and **Roxanne Hughes**, SciGirls teachers and graduate research assistants with CIRL, maintain contact with participants through the SciGirls blog that has been a great success (<http://scigirls.blogspot.com/>).

Research is ongoing on SciGirls as a model for encouraging young women to pursue higher level science courses as they enter high school and college. Current research focuses on past participants' choices of courses as they enter and/or continue in high school. In addition, the longitudinal study will track SciGirls participants as they enter college and make course and career choices.

Middle School Mentorship

Fourteen seventh graders from a local charter school participated in research conducted in various labs. Each of the 14 mentors who participated in 2009 worked with the students to develop a research project that tapped into the student's area of interest. At the end of the 13-week experience, students presented their work to scientists, parents, and other students. The program has sparked an interest in science and engineering for many of the students who have participated through CIRL since 1997.

Middle School Mentorships – Class of 2009

Students	Research Area	Mentors
Luna Beale Ashley Moore	Why Did the Titanic Sink?	Vince Toplosky Bob Walsh
Grant Banfill Riley Carson	Mechanical Properties of Rolled Copper	Nicholas Bembridge Peter Kalu
Micah Novey Grace Rogers	The Fluidyne Sterling Engine	Lloyd Engel
Francis Bass Amelia Carroll	Extinction of the Woolly Mammoth	Afi Sachi-Kocher Naoki Shirai Soumen Mallick Nicole Tibbetts
Teddy Bruner Olivia Merkhofer	Solar Energy	Hans van Tol
Corey Afton Tristan Kirby	Force Balance Measurements	William S. Oates Farrukh Alvi
Hallie Gaudio Sylvia Portillo	Marquee Lights	Phil Kuhns Arneil Reyes

High School Internships

In 2009, seven high school students worked at the Magnet Lab in semester-long internships. Each of the students expressed an interest in working at the lab to learn more about real-world science and engineering.

High School Mentorships – Class of 2009		
Student	High School	Mentor
Carolyn Kim	Chiles High School	Stan Tozer
Kyle Petrovich	Chiles High School	Arneil Reyes
Mike Walker	Chiles High School	Iain Dixon
Esha Atolia	Rickards High School	Ryan Rodgers
Aditi Hota	Rickards High School	Mike Davidson
Mayon Hight	Lincoln High School	Iain Dixon
Carissa Redmon	Chiles High School	Steve Van Sciver

Professional Development

CIRL continues to provide content-rich, inquiry-based activities in full-day and after-school workshops. In an effort to engage more teachers in meaningful ways, CIRL provides monthly workshops that focus on the nature of science and the process of science while presenting activities that teachers can use to enhance the content they are currently teaching. A research project is planned for academic year 2010-2011 to determine if this workshop model results in increased numbers of teachers using the activities.



Carlos Villa and **Brandon Nzekwe** discuss professional development opportunities with area teachers

Conference Presentations and Articles

One article was published in 2009: **Grove, C.M., Dixon, P.J. and Pop, M.M.**, "Research experiences for teachers: Influences related to expectancy and value of changes to practice in the American classroom", *Professional Development in Education*, **35** (2), 247-260 (2009). Two others will be published in 2010.

Carlos Villa, Outreach Coordinator, presented at the National Science Teachers Association (NSTA) national conference as well as at the regional NSTA conference, highlighting the Magnet Lab as a resource for K12 educators.

Papers and posters were presented at the following conferences: Association for Science Teacher Education, National Association for Research in Science Teaching, American Educational Research Association, Eastern Educational Research Association, American Geophysical Union, Materials Research Society, and Women in Education.

Chapter 7: Industrial Partners & Collaborations

Magnet Lab researchers and staff develop partnerships and collaborations with the private sector, federal agencies and institutions, and international organizations, resulting in a wide variety of magnet-related technologies and advancing other projects that bring technologies closer to the marketplace. Engaging in these kinds of research-and-development activities is part of the National Science Foundation's charge to the Magnet Lab.

Magnet Lab Private Sector Activities

89 North, Burlington, VT

Scientists at the Magnet Lab are working with applications specialists at 89 North to develop light-emitting diode technology for fluorescence microscopy. This collaboration involves testing the power output and usability of new high-power LED technology in the emission region between 490 and 590 nanometers, a spectral region that is central to microscopy investigations.

(Magnet Lab contact: Mike Davidson, Optical Microscopy)

Abbott Laboratories, Abbott Park, Chicago, IL

This collaboration is with Shaun McLaughlin, senior research physical chemist at Abbott Pharmaceuticals. McLaughlin is collaborating with the ICR program on epitope mapping of specific antibodies toward the NoGo protein using Hydrogen-deuterium exchange at 14.5 tesla. The NoGo protein is involved in neurite growth inhibition. Specific inhibition of NoGo would be a useful tool to aid repair of spinal cord injuries. NoGo inhibitors have also been targeted for treatment of brain damage after stroke.

(Magnet Lab contact: Mark R. Emmett, ICR)

Allele Biotech, San Diego, CA

Allele is a manufacturer and distributor of fluorescent protein constructs made by Robert Campbell and Nathan Shaner. The Magnet Lab is collaborating with Allele to develop fusion vectors of selected fluorescent proteins.

(Magnet Lab contact: Mike Davidson, Optical Microscopy)

B&B Microscopes, Pittsburgh, PA

Scientists in the Optical Microscopy facility at the Magnet Lab are working with B&B engineers to develop new live-cell imaging techniques using the wide array of products offered by the company. Eventually, an educational Web site is planned.

(Magnet Lab contact: Mike Davidson, Optical Microscopy)

Bioptechs, Butler, PA

The Magnet Lab is involved with Bioptechs of Pennsylvania to develop live-cell imaging techniques using the company's advanced culture chambers. The collaboration involves time-lapse imaging of living cells over periods of 36-72 hours using techniques such as differential interference contrast, fluorescence, and phase contrast.

(Magnet Lab contact: Mike Davidson, Optical Microscopy)

Chroma, Rockingham, VT

A major supplier of Interference filters for fluorescence microscopy and spectroscopy applications, Chroma is collaborating with the Magnet Lab to build educational tutorials targeted at fluorescence microscopy. Working in conjunction with Nikon, engineers from Chroma and scientists from the Magnet Lab are examining the characteristics of a variety of filter combinations.

(Magnet Lab contact: Mike Davidson, Optical Microscopy)

ConocoPhillips, Houston TX

In-reservoir biodegradation can alter the composition of a parent petroleum fluid and cause problems in production and refining. In collaboration with ConocoPhillips, the Magnet Lab's Ion Cyclotron Resonance group has analyzed a series of samples collected at different vertical and horizontal sampling locations within a single reservoir. The mass spectral results serve as a compositional map of the reservoir and indicate areas of increased microbial activity. The compositional information from the acidic species has been shown to provide a useful indicator for the degree of biodegradation in the reservoir.

(Magnet Lab contact: Ryan Rodgers, ICR)

The Cooke Corp., Romulus, MI

Scientists at the Magnet Lab are working with applications specialists at Cooke to field test the company's cooled and electron multiplied scientific CCD camera systems. Demanding applications in quantitative image analysis and high-resolution images are being explored as well as time-lapse fluorescence microscopy and resonance energy transfer imaging.

(Magnet Lab contact: Mike Davidson, Optical Microscopy)

Covance Research Products, Berkeley, CA

Covance is a biopharmaceutical company involved with research and diagnostic antibody production. Magnet Lab scientists are working with Covance researchers to examine immunofluorescence staining patterns in rat and mouse brain thin and thick sections using a wide spectrum of antibodies.

(Magnet Lab contact: Mike Davidson, Optical Microscopy)

Diagnostic Instruments, Sterling Heights, MI

Scientists at the Magnet Lab are working with applications specialists at Diagnostics to field test the company's new line of cooled scientific CCD systems. Demanding applications in quantitative image analysis and high-resolution images are being explored as well as time-lapse fluorescence microscopy and resonance energy transfer imaging.

(Magnet Lab contact: Mike Davidson, Optical Microscopy)

Falk Center for Molecular Therapeutics, Northwestern University, Evanston, IL

Joseph R. Moskal and Roger A. Kroes are collaborating with the FT-ICR group on the inhibition of invasion of glioblastoma brain tumors through gene therapy. Drs. Moskal and Kroes bring their unique glyco-gene array technology and expertise in the field of Glycomics to the collaboration, which permits a Systems Biology approach (proteomics, lipidomics, glycomics, transcriptomics and phenotypic response) to the search for therapeutic targets for treatment of glioblastoma brain tumors.

(Magnet Lab contact: Mark R. Emmett, ICR)

Foveon, Santa Clara, CA

A corporation exploring true color "complementary metal-oxide semiconductor" (CMOS) image sensor technology, Foveon is involved with developing educational tutorials with the Magnet Lab that explain its cutting-edge technology in image sensor design.

(Magnet Lab contact: Mike Davidson, Optical Microscopy)

Hamamatsu Photonics, Bridgewater, NJ

Scientists at the Magnet Lab are working with applications specialists at Hamamatsu to field test the company's cooled and electron multiplied scientific CCD camera systems. Demanding applications in quantitative image analysis and high-resolution images are being explored as well as time-lapse fluorescence microscopy and resonance energy transfer imaging.

(Magnet Lab contact: Mike Davidson, Optical Microscopy)

Lumencor Inc. Beaverton, OR

The Magnet Lab is collaborating with Lumencor to examine the spectra and output power of various illumination sources for microscopy including metal halide lamps, light engines, LEDs and the LiFi illumination system.

(Magnet Lab contact: Mike Davidson, Optical Microscopy)

MBL International, Woburn, MA

Scientists at the Magnet Lab are collaborating with MBL to develop new fluorescent proteins for live-cell imaging applications. These include both optical highlighters and FRET biosensors.

(Magnet Lab contact: Mike Davidson, Optical Microscopy)

Media Cybernetics, Silver Spring, MD

Programmers at the Magnet Lab are collaborating with Media Cybernetics to develop imaging software for time-lapse optical microscopy. In addition, the Optical Microscopy group is working to add new interactive tutorials dealing with fundamental aspects of image processing and analysis of data obtained with the microscope.

(Magnet Lab contact: Mike Davidson, Optical Microscopy)

Molecular Probes/Invitrogen, Eugene, OR

A major supplier of fluorophores for confocal and widefield microscopy, Molecular Probes is collaborating with the Magnet Lab to develop educational tutorials on the use of fluorescent probes in optical microscopy. (Magnet Lab contact: Mike Davidson, Optical Microscopy)

Nalco, Sugarland, TX

Deposits formed in petroleum production equipment pose major obstacles to safe, economical production of heavy oils in both terrestrial and deep offshore production environments. With the help of Nalco, the FT-ICR group has provided detailed compositional analysis for emerging production deposits for new and late production oil reserves all over the globe. The compositional information is vital to the design of the next generation of chemical dispersants and inhibitors to reduce deposition in the transport of heavy petroleum reserves. Another concern is that many species in oil that are soluble under reservoir conditions (high temperature and pressure) become unstable when oil production starts. Their precipitation poses significant problems. The FT-ICR facility has begun the compositional analysis of pressure-induced and temperature-induced precipitants from live oil samples in collaboration with Chevron. The results show that specific classes (chemical functionality) preferably precipitate when either the temperature or pressure is dropped from reservoir conditions. (Magnet Lab contact: Ryan Rodgers, ICR)

Nikon USA, Melville, NY

The Magnet Lab maintains close ties with Nikon on the development of an educational and technical support microscopy Web site, including the latest innovations in digital imaging technology. As part of the collaboration, the Magnet Lab is field-testing new Nikon equipment and developing new methods of fluorescence microscopy. (Magnet Lab contact: Mike Davidson, Optical Microscopy)

Olympus America, Melville, NY

The Magnet Lab is developing an education/technical Web site centered on Olympus products and will be collaborating with the firm on the development of a new tissue culture facility at the Magnet Lab in Tallahassee. This activity will involve biologists at the Magnet Lab and will feature Total Internal Reflection Fluorescence microscopy. (Magnet Lab contact: Mike Davidson, Optical Microscopy)

Omega Optical, Brattleboro, VT

The Magnet Lab is involved in collaboration with Omega to develop interactive tutorials targeted at education in fluorescence filter combinations for optical microscopy. Engineers at Omega work with Magnet Lab microscopists to write review articles about interference filter fabrication and the interrelationships between various filter characteristics and fluorophore excitation and emission. (Magnet Lab contact: Mike Davidson, Optical Microscopy)

Oxford Superconductor Technologies (OST) Carteret, NJ

The manufacturer of Nb_3Sn superconducting wire is collaborating with the laboratory's Materials Development and Characterization Group in researching its latest advanced low temperature superconductors. The lab's superconductor wire test facility is designed for tests of the critical current versus strain behavior of Nb_3Sn conductors. Materials scientists at Oxford are assisting by providing the latest advanced superconductors and consultation on test results and analysis. (Magnet Lab contact: Bob Walsh, MS&T)

Pfizer Global Research & Development, San Diego, CA

Dr. Michael Greig at Pfizer is collaborating with the ICR program in a novel application of supercritical fluid chromatography to separate peptides following hydrogen-deuterium exchange experiments, thereby essentially eliminating deuterium-hydrogen back-exchange that had been the primary drawback to such analyses. This idea was a specific aim of the recently funded National Institutes of Health project for which Greig is a contributor. (Magnet Lab contact: Mark Emmett, ICR)

Photometrics (Roper Scientific Inc.), Tucson, AZ

The microscopy research team at the Magnet Lab is exploring single molecule fluorescence microscopy using electron-multiplying CCD camera systems developed by Photometrics. In addition, the team is conducting routine fixed-cell imaging with multiple fluorophores to gauge camera performance. (Magnet Lab contact: Mike Davidson, Optical Microscopy)

Photonics Instruments, Pittsfield MA

The microscopy research team at the Magnet Lab is collaborating with engineers at Photonics Instruments to develop photoactivation techniques for widefield and spinning disk confocal microscopy. This collaboration involves live-cell imaging techniques.
(Magnet Lab contact: Mike Davidson, Optical Microscopy)

Prior Scientific Inc., Rockland MA

Prior is a major manufacturer of illumination sources and filter wheels for fluorescence microscopy. The Magnet Lab team is collaborating with Prior to develop new illumination sources and mechanical stages for all forms of microscopy.
(Magnet Lab contact: Mike Davidson, Optical Microscopy)

Schlumberger-Doll Research, Ridgefield, CT

This research focuses on the correlation between downhole fluid behavior and composition determined by FT-ICR mass spectrometry. Additional research projects aim at compositional variations in reservoir fluids that reveal compartmentalization (i.e. multiple isolated compartments present in a single reservoir). Both projects address the biggest current problems in reservoir risk management.
(Magnet Lab contact: Ryan Rodgers, ICR)

Semrock, Rochester, NY

The Magnet Lab Optical Microscopy group is collaborating with Semrock to develop interactive tutorials targeted at education in fluorescence filter combinations for optical microscopy. Engineers and support personnel at Semrock work with Magnet Lab microscopists to write review articles about interference filter fabrication and the interrelationships between various filter characteristics and fluorophore excitation and emission. In addition, Magnet Lab scientists produce images of living cells with Semrock filter combinations.
(Magnet Lab contact: Mike Davidson, Optical Microscopy)

Shell Global Solutions, Houston TX

The FT-ICR group has an ongoing collaboration with Shell, USA to explore new mass spectrometric ionization techniques for characterization of petroleum crude oil and its products. Current efforts involve application of atmospheric pressure photoionization (APPI) to provide access to non-polar components (e.g., hydrocarbons, thiophenes, etc.) not accessible by conventional electrospray ionization. Fundamental research in APPI determines relative ionization efficiencies of chemical types known to exist in crude oil.
(Magnet Lab contact: Ryan Rodgers, ICR)

Sierra Analytics, Modesto, CA

The lab's ICR research team maintains a licensing agreement with Sierra, a company that provides mass spectrometry software to petroleum companies. The software contains high level algorithms for identification of thousands of compounds in petroleum mass spectra, obtained through the lab's pioneering Fourier transform ICR technique development. Lab researchers and Sierra Analytics continue to share updated information, enabling both to stay atop the petroleomics field.
(Magnet Lab contact: Chris Hendrickson, ICR)

SouthWest Research Institute (SwRI), Mechanical and Materials Engineering Division, Houston, TX

The evaluation of a digital X-ray system for the inspection of conduit welds was performed through collaboration between MS&T and SwRI. The Series Connected Hybrid (SCH) magnet utilizes Cable-in-Conduit-Conductor (CICC) technology and has about 300 conduit welds that require Non-Destructive Evaluation (NDE) with respect to the design allowable maximum flaw size. The research concludes that the X-ray system has acceptable resolution of weld defects if the conduit is absent of the insert superconducting cable, and unacceptable resolution if the insert cable is present. The outcome of this research directly influenced the manufacturing plan for the SCH-CICC magnets.
(Magnet Lab contact: Bob Walsh, MS&T)

Sutter Instrument, Novato, CA

The Magnet Lab is collaborating with Sutter to examine the spectra and output power of various illumination sources for microscopy including metal halide lamps and the LiFi illumination system.

(Magnet Lab contact: Mike Davidson, Optical Microscopy)

Technique Materials Inc., Lincoln, RI

Technique Materials Inc. is a company specializing in fabrication of materials via glazing, plating, and coating. The company and the laboratory have undertaken a joint research project on fabrication of high strength conductors for next-generation magnets. Because of the high efficiency of the fabrication approach, nanostructured conductors can be fabricated in a reasonable time.

(Magnet Lab contact: Ke Han, MS&T)

Training Solutions Interactive Inc., I4 Learning, Atlanta, GA & Tallahassee, FL

TSI and the Center for Integrating Research & Learning have been collaborating since 1998 to bring "Science, Tobacco & You" to more than 20 states. TSI specializes in the implementation of programs, systems, and strategies to improve efficiency and productivity in business, industry and education. Because of the overwhelming success of "Science, Tobacco & You", TSI and the Center continue to maintain an active and dynamic business relationship. Anticipated projects include an update of "Science, Tobacco & You" and physics curriculum materials for high school students and teachers.

(Magnet Lab contact: Pat Dixon, Educational Programs)

Zeiss Micro Imaging, Thornwood, NY

The Optical Microscopy group at the Magnet Lab is negotiating a contract with Zeiss on the development of an educational and technical support microscopy Web site, including the latest innovations in digital imaging technology. As part of the collaboration, microscopists are field-testing new Zeiss equipment and developing new methods of fluorescence microscopy.

(Magnet Lab contact: Mike Davidson, Optical Microscopy)

Inter-Agency and Inter-Institutional Activities**Character and Heritage Institute, Tallahassee, FL**

The Magnet Lab Center for Integrating Research & Learning works with president and CEO Gail Rossier to create innovative science programs for middle-school students, including "Operation Filmmaker Goes Science" summer camp.

(Magnet Lab contact: Pat Dixon, Educational Programs)

Columbia University, Stanford University, University of California Santa Barbara, University of Rhode Island

The Center for Integrating Research & Learning continues its collaboration with other institutions that conduct educational outreach with teachers. Through the Research Experiences for Teachers (RET) Network, the Center maintains a national presence among other laboratories, centers, and universities that conduct RET and other teacher enhancement programs. Current projects include expansion of the current RET Network Web site to include input from additional sites and an interactive component to share best practices. In addition, the RET Network will be a comprehensive site that compiles lists of RET programs across the country.

(Magnet Lab contact: Pat Dixon, Educational Programs)

International Thermonuclear Experimental Reactor (ITER), US-ITER Project Office, Oak Ridge, TN

The United States is part of an international collaboration to construct and operate ITER, a full-scale experimental device designed to demonstrate the feasibility of the production of fusion energy. The Magnet Lab's Magnet Science and Technology Group is assisting in the research and development of large superconducting magnets and components for the enormous Fusion Reactor Tokamak. Engineers in MS&T are collaborating on magnet design topics such as stress analysis, component tests, and materials characterization.

(Magnet Lab contact: Bob Walsh, MS&T)

Lawrence Berkeley Lab, Accelerator & Fusion Research, Berkeley, CA

The Magnet Lab collaborates in the measurement of the critical current of Nb₃Sn cables under transverse pressure at 4.2 K and in magnetic fields up to 12 T, on candidate conductors for dipole magnets for the Large Hadron Collider Accelerator Research Program.

(Magnet Lab contact: Huub Weijers, MS&T)

Leon County Schools, Tallahassee, FL

The Center for Integrating Research & Learning facilitates science workshops and summer institutes for Leon County Schools. With high stakes testing in science now part of school accountability, the Center has responded to the call of teachers and schools to provide quality professional development. The Center currently maintains formal partnerships with two elementary schools, three middle schools, and two high schools.

(Magnet Lab contact: Pat Dixon, Educational Programs)

Mary Brogan Museum of Art and Science, Tallahassee, FL

The lab's Center for Integrating Research and Learning partners with The Brogan to create an interactive exhibit that translates complex science concepts for the general public.

(Magnet Lab contact: Pat Dixon, Educational Programs)

M.D. Anderson Cancer Center, Houston, TX

This collaboration with Charles A. Conrad, M.D., associate professor of neuro-oncology and medical director of the Anne C. Brooks Neuro Center, involves the study of a protein (galectin-1) as a therapeutic target in the progression of glioblastoma multiforme brain tumors. The galectin target was discovered in previous collaborations between Conrad, Carol L. Nilsson (then of Goteborg University), and Mark R. Emmett of the FT-ICR program. The initial collaboration was primarily funded by a Swedish STINT grant. Recently, Mike Davidson, director of the Magnet Lab's Optical Microscopy group, joined the collaboration to provide high-resolution fluorescent photomicroscopy of the live glioblastoma cell lines.

(Magnet Lab contacts: Mark Emmett, ICR, and Mike Davidson, Optical Microscopy)

Spallation Neutron Source, Oak Ridge, TN

In late 2006 the National Science Foundation awarded funding to a team including researchers at Johns Hopkins University, the Magnet Lab, the Spallation Neutron Source (SNS), and MIT for a Conceptual Engineering Design of a conical Series Connected Hybrid magnet suitable for neutron scattering at the SNS. The three-year study includes development of a conical resistive magnet. A conceptual magnet design has been developed. Members of the potential user community at the SNS discussed the beamline concepts in April 2008. Design reviews of the magnet were held in November 2007 and January 2009. A proposal for construction of the magnet was submitted in July 2009.

(Magnet Lab contact: Mark D. Bird, MS&T)

International Activities

Andor-Tech, Belfast, Northern Ireland

Andor-Tech is an imaging specialist involved with development of CCD camera systems designed to produce images at extremely low light levels. The Magnet Lab is collaborating with Andor-Tech to produce interactive tutorials describing electron multiplying CCD (EMCCD) technology and will work with the company to test new camera products in live-cell imaging.

(Magnet Lab contact: Mike Davidson, Optical Microscopy)

CoolLed Ltd., Andover, Hampshire, UK

Scientists at the Magnet Lab are working with applications specialists at CoolLed to develop light-emitting diode technology for fluorescence microscopy. This collaboration involves testing the power output and usability of new LED technology in the emission region between 490 and 590 nanometers, a spectral region that is central to microscopy investigations.

(Magnet Lab contact: Mike Davidson, Optical Microscopy)

Evrogen, Moscow, Russia

Evrogen is a manufacturer and distributor of fluorescent protein constructs made by Dmitriy Chudakov and Vladislav Verkhusha. The Magnet Lab is collaborating with Evrogen to develop fusion vectors of selected fluorescent proteins.

(Magnet Lab contact: Mike Davidson, Optical Microscopy)

EXFO, Mississauga, Ontario, Canada

The Magnet Lab is collaborating with EXFO to examine the spectra and output power of various illumination sources for microscopy including metal halide lamps, light engines, LEDs, and the LiFi illumination system.

(Magnet Lab contact: Mike Davidson, Optical Microscopy)

Helmholtz Center Berlin, Berlin, Germany

In March 2007 HZB (formerly the Hahn-Meitner Institute) signed an agreement with Florida State University Magnet Research and Development to develop a Series Connected Hybrid magnet suitable for neutron scattering experiments and to install it at HZB. The magnet is intended to provide 25 T on-axis using 4 megawatts of DC power and have upstream and downstream scattering angles of 30 degrees. An international panel of experts reviewed the design of the superconducting magnet and cryogenic system at the Magnet Lab in November 2007 and January 2009. Fabrication of the magnet is underway: superconducting strand has been delivered and is being cabled.

(Magnet Lab contact: Mark D. Bird, MS&T)

IFP, Lyon, France

Asphaltenes are one of the most problematic fractions of crude oil. Defined by their insolubility in n-heptane and solubility in toluene, they are the heaviest, most polar fractions of oil. Because world oil markets are moving toward heavier, more viscous fluids, they represent an ever-growing fraction of the whole crude. Asphaltenes are chemically complex, so complex that detailed speciation of individual components is not available outside high-resolution FT-ICR mass spectrometry. The High Field FT-ICR MS facility has an ongoing collaboration with IFP to look at the compositional changes in asphaltenes in thermal treatment processes aimed at the conversion of the heavy, viscous materials to light, less complex usable materials.

(Magnet Lab contact: Ryan Rodgers, ICR)

Institute of Metal Research, Chinese Academy of Sciences, Shenyang, China

The collaboration between the Institute of Metal Research and the Magnet Lab is related to the characterization of stainless steels and other structural materials for high field magnets. The materials are mainly stainless steel 316LN and maraging steels with high mechanical strength.

(Magnet Lab contact: Ke Han, MS&T)

Linkam, Surrey, United Kingdom

Scientists at the Magnet Lab collaborate with Linkam engineers to design heating and cooling stages for observation of liquid crystalline phase transitions in the optical microscope. In addition, microscopists are assisting Linkam in introducing a new heating stage for live-cell imaging in fluorescence microscopy.

(Magnet Lab contact: Mike Davidson, Optical Microscopy)

Olympus Corp., Tokyo, Japan

Investigators at the Magnet Lab have been involved in a collaboration with engineers at Olympus to develop and test new optical microscopy systems for education and research. In addition to pacing the microscope prototypes through basic protocols, the Optical Microscopy group is developing technical support and educational Web sites as part of the partnership.

(Magnet Lab contact: Mike Davidson, Optical Microscopy)

Qimaging, Burnaby, British Columbia, Canada

High-resolution optical imaging is the focus of the Magnet Lab collaboration with Qimaging, a Canadian corporation that specializes in CCD digital cameras for applications in quantitative image analysis and high-resolution images for publication. Target applications are interactive tutorials and image galleries that will be displayed on the Internet.

(Magnet Lab contact: Mike Davidson, Optical Microscopy)

Royal Dutch Shell, Amsterdam, The Netherlands

One of the more problematic oil field issues is the generation of sodium and calcium soaps during oil production. Known as naphthenates, they can lead to serious production issues and increased oil production costs. We collaborate with Dutch Shell to highlight the compositional information that can be obtained by FT-ICR MS to guide future analytical efforts.

(Magnet Lab contact: Ryan Rodgers, ICR)

Syncrude Research, Edmonton, Alberta, Canada

The largest petroleum reserve in North America rests in Alberta, Canada. With proven recoverable reserves approaching those of Saudi Arabia, Alberta will be an important supplier of petroleum crude oil to the United States in the near future. Although abundant, the Alberta reserves are heavily biodegraded and take the form of oil-soaked sand. The sand is mined with conventional mining equipment, and oil is extracted by water to yield a petroleum product called bitumen. Bitumen is further refined and upgraded to produce synthetic crude oil ("syncrude"). Water extraction can form stable emulsions that significantly reduce the amount of recoverable oil. Furthermore, the large volumes of emulsion-laden water must be recycled to limit the water consumed in production. Recycling the water discharges large amounts of oil (in the form of emulsions) and other water-soluble oil components into the environment. In collaboration with Syncrude Research, we have analyzed the interfacial material responsible for the stable emulsion formation. The analysis identified chemical compound classes that preferentially accumulate in the interfacial material and stabilize the emulsion. Work is underway to design chemicals that interfere with those specific classes of compounds to prevent stable emulsion formation.

(Magnet Lab contact: Ryan Rodgers, ICR)

University of Science and Technology Beijing, Department of Materials Science and Engineering, Beijing, China

The collaboration between the University of Science and Technology Beijing and the Magnet Lab is related to the thermodynamic calculations of the multi elements and multiphase systems. Currently, efforts are focused on understanding interstitial elements impact on the precipitation in steels for high field magnets.

(Magnet Lab contact: Ke Han, MS&T)

Chapter 8: Conferences & Workshops

The Magnet Lab's focus on engaging users and collaborators as participants rather than just witnesses to the lab's cutting-edge research is reflected in the lab's 2009 conference and workshop schedule. A key example is the lab's first annual user summer school, which familiarized early career scientists with the workings of the Magnet Lab, from instrumentation to research results, and offered access to all the knowledge and tools needed to become productive researchers in the magnet research community. Workshops on exciting new technologies—the series connected hybrid and split-coil magnets—complemented participation in established large conferences.

Series Connected Hybrid Design Review

January 21-22, 2009

Tallahassee, Florida

Meeting site: National High Magnetic Field Laboratory

Workshop chair: Mark Bird

This workshop focused on the design work performed on the three Series Connected Hybrid magnets for the Magnet Lab, the Helmholtz Center Berlin, and the Spallation Neutron Source. Fifteen in-house faculty and staff members and three external contributors presented the work completed over the past year. Ten external reviewers and several representatives from each of the two external clients attended.

7th North American FT MS Conference

April 19-23, 2009

Key West, Florida

Meeting site: Key West Marriott Beachside Hotel

Conference chair: Alan Marshall

The FT MS Conference is held every two years and is the premier meeting of its kind in the field of Fourier transform mass spectrometry and its applications. Presentations ranged from instrumentation to technique development in the biological/biomedical sciences ranging from pharmaceutical metabolism to proteomics, environmental analysis and petroleomics, with special emphasis on new developments. Partial support for several contributed posters for graduate students and postdoctoral associates was offered. The conference hosted approximately 100 attendees.

National High Magnetic Field Laboratory Users Summer School

June 22-27, 2009

Tallahassee, Florida

Meeting site: National High Magnetic Field Laboratory

Workshop chair: Albert Migliori

The first Magnet Lab Users Summer School was organized by Albert Migliori, NHMFL-LANL, with assistance from Eric Palm and many others at NHMFL-FSU. The school provided an intense week of practical exercises, measurement tutorials, information technology tutorials, plenary discipline-spanning talks, and more. The goal was to give users a toolkit to help them obtain the most from the three campuses of this user facility. The 2009 session attracted 28 students who participated in classes taught by Los Alamos, FSU, and University of Florida instructors. The content was aimed at the advanced graduate students, postdocs, and junior or senior investigators who have used or intend to use Magnet Lab facilities. With two parallel sessions, students were able to get their hands on hardware, as well as listen to lectures.

Cryogenic Engineering Conference and International Cryogenic Materials Conference

June 28-July 2, 2009

Tucson, Arizona

Meeting site: JW Marriott Starr Pass Resort & Spa

Program Chair: Robert Walsh

The conference consisted of plenary, focused, and special sessions with oral and poster presentations covering all aspects of cryogenic engineering and materials. In addition, an extensive exhibit showcased the most up-to-date products and technologies in the cryogenics field. Along with Walsh's service as program chair and a short course taught by Steven Van Sciver, Magnet Lab group members participated heavily in the conference.

Pulsed EPR Workshop

July 6-10, 2009

Tallahassee, Florida

Meeting site: National High Magnetic Field Laboratory

Workshop chair: Stephen Hill

Twenty graduate students from FSU and UF physics, chemistry, and biology departments attended this workshop. Formal lecture topics included discussion of basic principles of spin-echo, pulse sequences for T1 and T2 measurements, more sophisticated pulse sequences leading e.g. to ESEEM, and double resonance (ENDOR, HYSCORE, then eventually DEER). Less formal discussion topics focused on instrumentation.

Optical Spectroscopy in the Split Florida Helix

October 1, 2009

Tallahassee, Florida

Meeting site: National High Magnetic Field Laboratory

Workshop chairs: Stephen McGill, Madalina Furis

In concert with the lab's User Committee Meeting, 12 presenters conducted a workshop on the possibilities for optical microscopy in the split Florida helix magnet that is under development. The workshop included a roundtable and a tour of the DC Field facility.

High Field Neuroimaging Workshop

October 26-27, 2009

Gainesville, Florida

Meeting site: McKnight Brain Institute, University of Florida

Workshop chair: Steve Blackband, Peter Vestergaard

The two-day workshop focused on research and training in high field neuroimaging. The workshop was supported primarily by the Danish National Research Foundation through a collaborative grant between The University of Florida (S. Blackband, principal investigator) and Aarhus University, Denmark (P. Vestergaard-Poulson, principal investigator), with additional support from the Magnet Lab and the McKnight Brain Institute.

The workshop was attended by 40 scientists from the United States, Canada, England, and Denmark, with an approximately even split between faculty and students. Topics included microscopy, functional imaging, molecular imaging, brain spectroscopy, diffusion imaging and techniques, and fiber tracking, with additional talks on new and novel cardiac and lung imaging. The scientific talks ranged from general overviews to highly technical and advanced technique development through applications. The simple format with 30-minute talks facilitated lively discussion among attendees. Following the meeting, faculty and students from UF and Aarhus held discussions on the ongoing research collaboration and potential future collaborative projects between the two groups, including perspectives that arose from the workshop.

14th US-Japan Workshop on Advanced Superconductors

December 14-15, 2009

Tallahassee, Florida

Meeting site: National High Magnetic Field Laboratory

Workshop chair: Eric Hellstrom

The workshop was organized and supported by the Magnet Lab and the Applied Superconductivity Center. Topics for presentation and discussion included BSCCO wires, cables, and applications; YBCO coated conductors, bulk, and applications; critical current and AC loss; thin films and device applications; structure, characterization, and new materials; and advanced metal superconductors. The workshop hosted approximately 70 attendees.

Chapter 9: Management & Administration

The Florida State University, the University of Florida and Los Alamos National Laboratory (with user programs at each of those locations) jointly operate the National High Magnetic Field Laboratory for the National Science Foundation under a cooperative agreement that establishes the lab's goals and objectives. FSU, as the signatory of the agreement, is responsible for establishing and maintaining administrative and financial oversight of the lab, and ensuring that the operations are in line with the objectives outlined in the cooperative agreement.

Management

The NHMFL Organizational Chart shows the detailed interfaces between internal and external organizations.

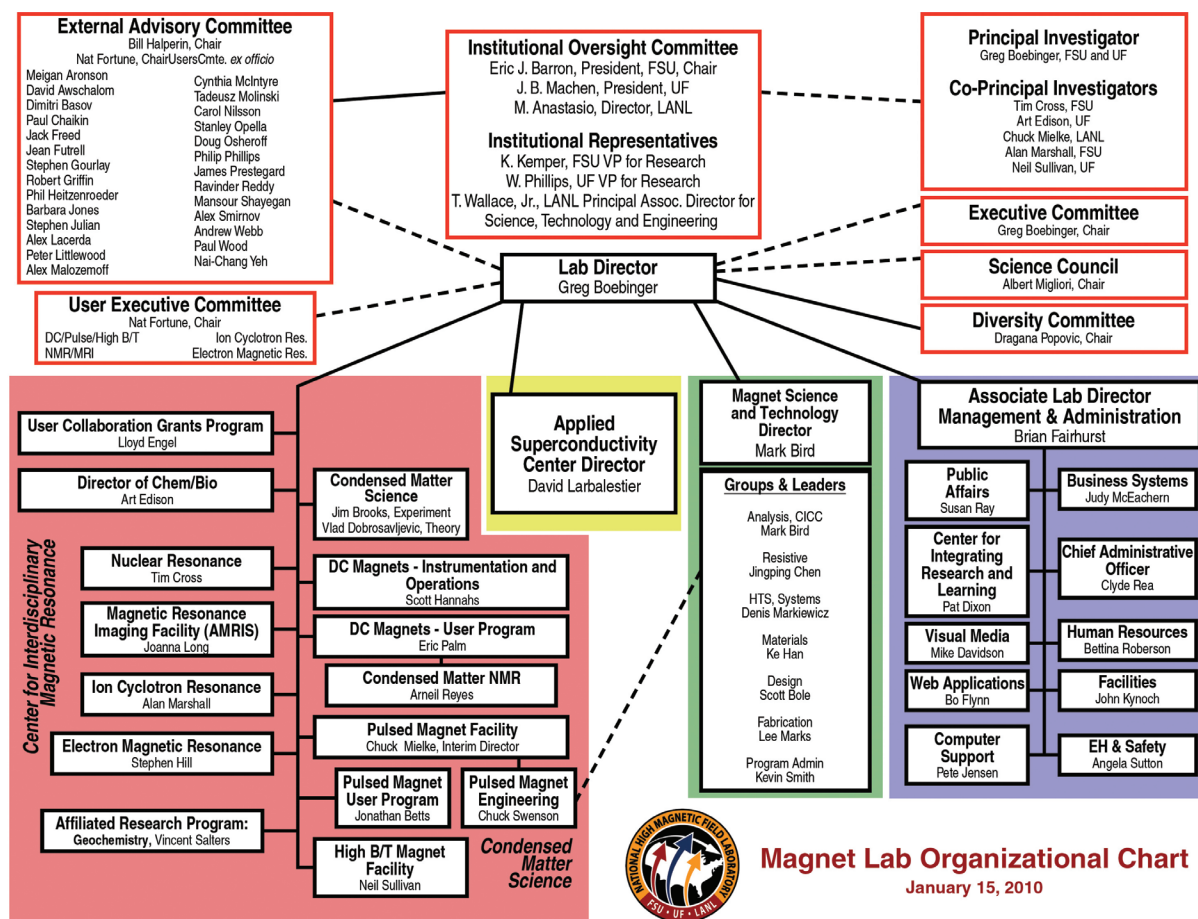

Gregory Boebinger serves as director and principal investigator of the Magnet Lab. He oversees the seven user programs, magnet science and technology, the activities of the Applied Superconductivity Center, and the associate director.

Brian Fairhurst serves as associate director for Management and Administration. He oversees budgeting and finance, human resources, facilities, health and safety, education, public affairs, web outreach and applications, computer support, information technology, and other administrative functions.

The Magnet Lab has five co-principal investigators on the NSF grant. They are:

- **Tim Cross** (FSU), Nuclear Magnetic Resonance program director
- **Arthur Edison** (UF), Chem/Bio director
- **Alan Marshall** (FSU), Ion Cyclotron Resonance program director
- **Charles Mielke** (LANL), Pulsed Magnet Facility interim director
- **Neil Sullivan** (UF), High B/T program director.

The lab's scientific direction is overseen by the **Science Council**, a multidisciplinary group of distinguished faculty from all three sites that serves as a think tank to consider and help guide the lab's scientific mission. Members are: **Albert Migliori (chair), Rafael Bruschweiler, Mark Emmett, Lev Gor'kov, Stephen Hill, David Larbalestier, Denis Markiewicz, Dragana Popović, and Glenn Walter.**

Two external committees meet regularly to provide critical advice on important issues. Reflecting the broad range of scientists who conduct research at the lab, the **Users Committee** provides guidance on the development and use of facilities and services in support of the work of those scientists. The **External Advisory Committee**, made up of representatives from academia, government, and industry, offers advice on matters critical to the successful management of the lab.

Personnel and Staffing

Five hundred eighty-eight (588) people worked for or were affiliated with the Magnet Lab at its three sites in 2009, down from 595 in 2008. Of that number, "senior personnel" represent the largest group at 32 percent; graduate students at 21 percent; technical/managerial support staff at 13 percent. The total distribution by NSF classification appears below.

NHMFL Staffing • Personnel at FSU, UF and LANL Distribution by NSF Classification • January 5, 2010 • Total Personnel: 588

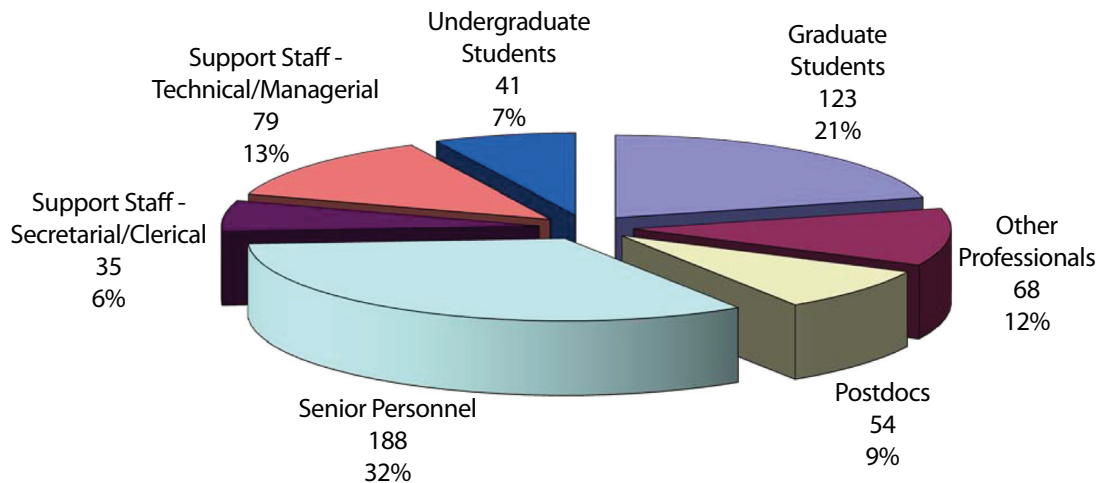

Of the science and engineering staff, senior personnel make up 51 percent; graduate students 34 percent; postdoctoral associates 15 percent.

Diversity

Since the adoption of the formal diversity plan in 2004, the Magnet Lab has pursued a multitude of activities and efforts to increase the participation of underrepresented groups in science, engineering, and mathematics.

The Magnet Lab aspires to become a nationally recognized leader in the diversity of its scientific, technical, and engineering staff, much the same way it is already recognized for its education and outreach programs. With this goal in mind, the lab in 2009 conducted the following activities:

- ▶ It continued its recruiting policies of including at least one member of the Magnet Lab Diversity Committee on each search committee for scientific and technical staff, and advertised job openings in venues that target women and minorities.
- ▶ Following the recommendation from the 2008 NSF Site Visit report, the lab explored ways to establish the Dependent Care Travel Grant Program, which seeks to assist and advance the careers of underrepresented groups including women by providing grants for travel-related expenses for dependents. The Diversity Committee developed the initial proposal, and further discussions are under way with the FSU Office of Research.
- ▶ The FSU Office of Diversity & Equal Opportunity conducted a training program at the Magnet Lab, which explored the different dimensions of diversity, challenges that arise from diversity, issues that surface in diverse workgroups, and methods for handling conflict.

The lab strives to provide an environment for success for members of underrepresented groups by providing mentors and opportunities to network within and beyond the Magnet Lab. For example, partial support was provided to **Hanna Terletska**, a physics Ph.D. student, to attend a two-week summer school on correlated systems in Italy, September 2009. She was able to secure external funding from the summer school, an I2CAM Junior Scientist Travel Award, and an award from FSU Congress of Graduate Students.

The lab continued its efforts to develop and cultivate individually crafted early career opportunities for members of underrepresented groups at the undergraduate level and above. In 2009, those efforts included the following:

- ▶ A continuation of the successful diversity lecture series, “College Outreach – Workforce Initiative Program” (CO-WIN) that sends Magnet Lab scientists and engineers to women’s colleges, and historically black and minority-serving colleges and universities. The following lectures were presented:
 1. **Ke Han**, August 28, North Carolina A&T State University, NC
 2. **Arthur Edison**, September 18, Claflin University, SC
- ▶ Following Ke Han’s CO-WIN trip to NCA&T, Prof. **Clinton Lee** of NCA&T came to Tallahassee at the end of October, 2009, as a visiting scientist for 4-6 weeks. His visit was funded by the Visiting Scientist Program.
- ▶ Following Arthur Edison’s visit to Claflin, special arrangements were made for 2010: Claflin will pick 1 nominee for the NHMFL REU program, and they will also provide matching funds to send a second student for summer training with Edison or another NMR lab at the NHMFL. In addition, Edison will schedule a follow-up trip to Claflin to give a “crash course” on NMR for about 1 week. This will be to get faculty and students trained in the basic theory and operations of solution NMR so that they can take full advantage of their new 700 MHz NMR instrument.
- ▶ Following Arthur Edison’s 2007 CO-WIN trip to Peru, a Peruvian undergraduate physics student **Christian Pascal** from Pontificia Universidad Católica Del Perú (PUCP) did research in Edison’s laboratory at UF 2 different times for 2-3 months each time. Christian was partially supported by NHMFL visiting scientist funds.
- ▶ The Diversity Program provided support to one 2009 REU student: **Blessing Ogbemudia** (Ohio State University). He worked with **Michael Davidson** on DNA cloning.
- ▶ Prof. **James Dickerson** from Vanderbilt spent his sabbatical at the NHMFL during the fall 2009 semester. He received support from the Visiting Scientist Program.
- ▶ The Magnet Lab provided year-round research opportunities to two FSU Women in Math, Science and Engineering (WIMSE) program students: **Kristen Collar** and **Alison Pawlicki**.
 1. Following her first successful year at the NHMFL that resulted in a published paper and a first place award in the Physics Department’s undergraduate poster symposium at FSU, **Collar** continued her research at the NHMFL, which included a December trip to the Pulsed Field Facility at Los Alamos to enhance her training. The Magnet Lab covered her travel expenses. In April 2009, Collar received the Lannutti Award for Undergraduate Research from the FSU Department of Physics.
 2. **Pawlicki** received the Lynn Shannon Proctor Fellowship for outstanding research by a student in a group that is underrepresented in the field of physics. The award is given in honor of Ms. Proctor, who was majoring in physics at the time of her death. Pawlicki was also inducted into the Sigma Pi Sigma honor society and took second place in the physics department’s undergraduate poster symposium.
- ▶ Support for part-time undergraduate research was also provided to **Lindsay Hardy** in spring 2009.
- ▶ Spring and summer 2009 support was provided to **Ivana Raičević**, FSU physics graduate student. Raičević, who was awarded a Ph.D. in physics in June 2009, also received travel support to attend the APS March meeting.
- ▶ Support was provided to **Hanna Terletska**, FSU physics graduate student, in fall 2009.
- ▶ Matching funds were awarded to several postdoctoral research associates: **Chiara Tarantini**, for research with the Applied Superconductivity Center (ASC); **Eugene Mananga**, for NMR research; and **Mika Kano** for research in the DC Field.
- ▶ **Stan Tozer** attended the 2009 Joint Annual Conference of the National Society of Black Physicists (NSBP) and Black Physics Students and the National Society of Hispanic Physicists (NSHP) held February 2009 in Washington, DC as an exhibitor and a recruiter.

- Registration fee was covered for **Tesfaye Gebre**, a postdoctoral researcher in Condensed Matter Science, to attend and present at the NSBP and NSHP conference in February 2009.
- Travel support was provided to **Jose Sanchez** (Center for Integrating Research and Learning, CIRL) to travel to Morehouse College in September 2009 to present information about the Magnet Lab, share information about the REU program, and attend a poster session. Sanchez also helped students with posters that were to be presented at the Annual Biomedical Research Conference where undergraduate research is featured. Sanchez and **Brandon Nzekwe** (graduate student) also visited Spelman College and Clark University to recruit for REU and to provide an overview for students and faculty on opportunities for research at the Magnet Lab.

One of the lab's goals is to aim educational outreach for K-12 and the general public to broad and diverse groups. This is accomplished through miscellaneous, individual efforts by the Magnet Lab scientists and staff, as well as by a variety of activities run by CIRL. In 2009, those efforts included the following:

- Four high school students worked on research projects with Magnet Lab scientists in the summer and fall.
- Judging at science fairs and mentorships at local schools. For example, **Eric Hellstrom, Jose Sanchez, Pat Dixon, Todd Adkins, Vlad Dobrosavljević** judged projects in schools that are labeled Title I or have a majority of underserved students. Arthur Edison continued to run a weekly science club in Gainesville for economically disadvantaged children in grades 2-5, with 9-10 children each week. He expanded the scope by including several volunteers from his lab, other labs at UF, and the education department at UF. They provide tutoring, development of social skills, and group activities doing science and math. They also feed the children sandwiches and fruit at the start of each session.
- **Pat Dixon** and **Jose Sanchez** conducted workshops for Title I schools in Leon County to help teachers translate the importance and excitement of science to elementary students. They also conducted similar workshops in Gadsden County, the third poorest county in Florida with failing elementary, middle, and high schools, with all schools designated as Title I schools.
- SciGirls I and SciGirls II 2009 camps provided science and engineering hands-on experiences to 33 middle school aged girls, as well as career education.
- CIRL worked with CROP to provide placement for a SciGirls participant and to conduct tours for middle school students from Gadsden County.
- Working with **Ira Flatow**, NPR's Science Friday host, CIRL connected SciGirls with Science Friday's outreach to students.
- **Jose Sanchez** conducted outreach for the second year in a row for Learning for Life, a program for underserved elementary students. Learning for Life is a character building program that starts in kindergarten and goes through to high school. It is run through the Boy Scouts and targets Title I schools and underserved students.
- CIRL worked with pre-service teachers from Flagler College to provide outreach to Title I elementary schools.
- CIRL conducted tours for FAMU bridging programs for middle and high school students.
- CIRL provided hands-on outreach to Capital Youth Services Program in Tallahassee serving minority populations within a 5-mile radius of the Magnet Lab.
- CIRL was Partner in Excellence with Fairview Middle School, a Title I school, providing consulting and services to teachers, staff and students.
- CIRL, working with Science Education and FSU Teach, was providing half day workshops on science inquiry for Fairview Middle School science teachers.
- CIRL has been working in 2009-2010 to provide outreach activities for the Boys and Girls Clubs of Jefferson County, Florida.
- CIRL continued its work with Sabal Palm Elementary School, a Title I school, to enhance its science offerings to students and to mentor students who wish to participate in the science fair.

- ▶ In partnership with CAPS, FAMU-FSU College of Engineering, North Carolina State University, and Arizona State University, CIRL facilitated the pre-college education project for the ERC FREEDM grant (NSF Engineering Research Center – Future Renewable Electric Energy Delivery and Management Systems Center) providing paid internships for 5 female high school students and 2 high school teachers from Godby High School (an underserved high school in Leon County).
- ▶ CIRL educators and graduate students **Kristen Molyneaux**, **Roxanne Hughes**, and **Brandon Nzekwe** presented papers at major educational research conferences on SciGirls and RET. Research resulted in two published articles in 2009.
- ▶ Science nights at local elementary schools resulted in outreach translating research at the Magnet Lab to over 500 members of the general public.
- ▶ CIRL partnered in Origins '09, a program at FSU designed to bring science to the general public.

The Magnet Lab's diversity web pages were identified as "best practice" in the 2009 NSF Business Systems Review.

Budget

The National High Magnetic Field Laboratory operates with funding provided by federal, institutional, and industry sources. In addition, the Magnet Lab faculty and staff have been very successful in securing individual research funding for specific areas of research from a variety of sources, including federal and private sectors. Although the lab receives funding from numerous sources, the National Science Foundation (NSF) is its primary funding source for operations.

NSF Facilities Budget

The National Science Foundation Division/Directorate approved the National High Magnetic Field Laboratory's facilities renewal award on December 12, 2007, with an effective date of January 1, 2008.

Table 1 provides a view of the current 5-Year award.

Table 1. NHMFL NSF 5-Year Budget (with Indirect Cost Distributed to Programs)¹

Division/Program	2008-2012 5-Year NSF Summary	% of Budget
Director's Office	1,466,060	0.99%
Associate Director/Management & Administration	13,660,860	9.18%
D C Field Facility	18,005,648	12.10%
Magnet Science & Technology	18,408,578	12.38%
Condensed Matter Science	5,375,854	3.61%
CIMAR - NMR	4,745,995	3.19%
CIMAR - ICR	7,570,645	5.09%
CIMAR - EMR	1,105,073	0.74%
CIRL & REU	1,365,530	0.92%
ASC	2,930,023	1.97%
Electricity & Gases	34,244,488	23.02%
LANL	29,064,823	19.54%
UF - High B/T	1,738,032	1.17%
UF- AMRIS	3,898,083	2.62%
Diversity	599,826	0.40%
User Collaborative Grants Program ²	4,570,482	3.07%
Total NSF Cooperative Agreement	\$148,750,000	100.00%

¹ FY 2008 included a \$26,500,000 award plus supplement funding of \$1,250,000 resulting in a total award of \$27,750,000. FY 2009 award was \$31,500,000. In 2009, the laboratory received the first funding increment of \$22,525,000 plus a supplement of \$3,975,000. The laboratory also received ARRA funding in the amount of \$5,000,000 which is not included in the above table. FY 2010 award is assumed to be \$26,500,000.

The National Science Foundation (National Science Board) approved funding of up to \$162,000,000 for 2008-2012.

² UCGP (User Collaboration Grants Program) for FSU/NHMFL, LANL and UF reported as one line item.

Table 2 presents the annual NSF budgets for the 5-Year award period.

Table 2. NHMFL - NSF Budget by Program (with Indirect Cost separate from programs)

Division/Program	2008	2009	2010	2011	2012	Total Budget
Director's Office	578,614	-453,866	149,038	114,925	113,361	502,072
Associate Director/ Management & Administration	1,554,740	1,676,171	1,642,891	2,278,394	2,315,820	9,468,016
D C Field Facility	2,286,768	2,168,960	2,151,060	2,754,017	2,802,336	12,163,141
Magnet Science & Technology	2,340,153	2,250,915	2,298,109	3,413,637	2,432,915	12,735,729
Condensed Matter Science	500,894	953,785	974,190	548,454	559,423	3,536,746
CIMAR - NMR	587,040	623,469	650,256	717,293	728,843	3,306,901
CIMAR - ICR	961,673	1,053,252	1,119,366	1,074,149	1,093,167	5,301,607
CIMAR - EMR	131,519	133,475	138,930	172,002	175,042	750,968
CIRL & REU ³	187,807	216,087	224,090	205,043	209,146	1,042,173
ASC	447,101	490,014	492,027	290,938	296,921	2,017,001
Electricity & Gases	5,791,897	4,779,676	3,987,789	7,985,682	9,066,735	31,611,779
LANL	2,895,534	3,065,568	2,418,243	2,545,810	2,593,488	13,518,643
UF - High B/T	212,483	273,940	272,036	239,991	243,928	1,242,378
UF- AMRIS	500,159	562,705	556,443	605,862	614,980	2,840,149
Diversity	64,073	64,001	64,642	106,067	108,811	407,594
User Collaboration Grant Program ⁴	897,225	911,400	808,143	967,185	986,529	4,570,482
Indirect Cost	7,812,320	7,730,448	8,552,747	9,980,551	9,658,555	43,734,621
Total	\$27,750,000¹	\$26,500,000²	\$26,500,000	\$34,000,000	\$34,000,000	\$148,750,000

¹ Year 2008 includes supplement funding of \$1,250,000.

² Year 2009 award was \$31,500,000 including ARRA funding of \$5,000,000. As noted from the previous table, ARRA funds are being reported separately. The 2009 award was funded in three increments: \$22,525,000, \$3,975,000 and ARRA funds of \$5,000,000

³ CIRL & REU includes RET funding of \$70,358 for 2008 and \$95,357 for 2009.

⁴ UCGP (User Collaboration Grants Program) funding is reported as total research funds for FSU/NHMFL, UF, and LANL.

The following table, **Table 3**, summarizes the Magnet Lab's budget position as of December 31, 2009. The budget balance represents deferred capital and expense items, such as resistive magnets maintenance and upgrade, split magnet equipment purchases and other miscellaneous equipment.

Table 3. Cumulative NSF Budget and Expenses (01/01/08 - 12/31/09)

Expense Classification	Budget	Spent and Encumbered	Balance 12/31/2008
Salaries and Fringe	14,403,580	13,581,314	822,266
Subawards	14,211,296	14,390,938	-179,642
Capital Equipment	2,331,380	3,258,068	-926,688
Other Direct cost	12,928,433	13,688,047	-759,614
Subtotal	43,874,689	44,918,367	-1,043,678
Indirect	9,909,704	9,775,482	134,222
Total before Indirect on Encumbrances	\$53,784,393	\$54,693,849	-\$909,456
Estimated Indirect on Encumbrances	465,607	465,607	0
Adjusted Total	\$54,250,000	\$55,159,456	-\$909,456¹
Program Income	0	0	0

¹ The negative balance is a result of equipment commitments made in 2009 in order to maintain schedules based on delivery lead times.

Matching Commitment

The NSF award includes a matching commitment by the State of Florida through Florida State University that is 10% of the annual award. In addition, the State of Florida also provides institutional funds to the laboratory above the NSF matching requirement. The Magnet Lab utilizes these additional state resources as cost-sharing funds for other funding opportunities, as well as to help support other NSF activities. **Table 4** presents the State of Florida matching requirements and contribution provided through FSU.

Table 4. Fiscal Year 2009/2010 State of Florida Matching and Contribution

	State Matching	State Contribution	Total State Funding
State of Florida Recurring Funds Cost-Sharing	2,650,000	6,613,208	9,263,208
Indirect Cost (52%)	1,378,000	3,438,868	4,816,868
Total	\$4,028,000	\$10,052,076	\$14,080,076

American Recovery and Reinvestment Act (ARRA) Funding

In 2009, the laboratory received a \$5,000,000 ARRA award from the NSF that provided the flexibility for the lab to up-grade systems, magnets, and purchase upgrades for imaging and spectroscopy consoles.

ARRA funds were used to ameliorate prior budget reductions. Cumulative underfunding of the 5-Year NSF award led to the deferment of equipment replacement, preventive maintenance, projects, and a reduction in DC magnet operations. The receipt of ARRA funds provided the NHMFL the ability to reinstate many of the deferred items.

A *helium liquefier system* is being purchased and installed to replace unreliable equipment that is 18-20 years old. This system will upgrade the cryogenics plant enabling the lab to maintain a state of the art facility for users. A magnet cooling pump will also be purchased and installed to support the helium purification needs associated with the upgrade. The Florida State University has provided supplementary funds in the amount of \$1.9 million dollars to support this enhancement.

The system components include a *liquefier* that will be used to recover helium gas via a lab-wide recovery system, purify and liquefy helium for re-use as coolant for superconducting magnets, and for use with samples during scientific experiments.

A *central helium distribution box*, comprising valves, heat exchangers, and helium sub coolers, is being purchased to supply liquid helium for the 45 tesla hybrid magnet system and for the cryogenic shields. This is an interface between the output of the 750 W turbine helium liquefier and the current cooling system of the 45 tesla magnet. The system is also designed for future expansion and the next generation of hybrid magnets.

Vacuum jacketed transfer lines are a necessity for coupling the *central distribution box* to the 45 tesla hybrid. These transfer lines will enable the cost-effective (and environmentally friendly) transfer of liquid helium.

The NHMFL is committing \$475,270 from other non-federal funding sources to support the *purchase of a new magnet cooling pump system*. The total cost of the project is \$575,270, which includes \$350,000 for a pump. ARRA funds in the amount of \$100,000 will be applied to the purchase of a pump. The magnet cooling pump will provide increased cooling efficiency and the ability to operate longer magnet "run times" during user research projects.

Equipment purchases at the Los Alamos National Laboratory (LANL), via a sub-award, includes \$639,000 to purchase emergency replacement parts for the 60T and 100T Long Pulse Magnet Systems. The *NHMFL Renewal Proposal, Section 2.2: Realizing the Science, Page 31* clearly stated *..."pulsed magnets are essentially "applied metal fatigue"; the consumption of 100T (and 60T) insert coils is a new and ongoing cost to the pulsed magnet program."* Without these replacement parts, any magnet failure will require immediate suspension of the respective Pulsed Magnet User Program.

Also, a *cryostat* will be purchased and installed at LANL - \$71,013. Low loss cryostats decrease the consumption of liquid helium for magnet systems that are used in the User Program. The improved efficiency is required to offset the increasing costs of liquid helium.

Equipment purchases for the Advanced Magnetic Resonance Imaging and Spectroscopy (AMRIS) Program at the University of Florida, via a sub-award, includes \$200,000 to *purchase upgrades* for imaging and spectroscopy consoles. Four of the current consoles are over ten years old and nearing the end of their useful lives. Frequent component breakdowns are negatively impacting the NHMFL user program. However, commercial NMR instrument manufacturers have made great strides in digital technology over the last decade and *modernizing the AMRIS consoles* will yield gains in sensitivity, dynamics range, and pulse sequence programming that would further leverage the already impressive performance of our high magnetic fields and radiofrequency coils. These upgrades are necessary to support cutting-edge imaging and *in-vivo* spectroscopy experiments that are required by NHMFL external users.

NSF Business System Review

During late 2008 and early 2009, the NSF conducted a Business System Review (BSR) of the NHMFL/FSU. The following subject areas were reviewed:

- General Management
- Award Management
- Human Resources
- Financial Management
- Property and Equipment
- Financial Reporting
- Procurement
- Budget and Planning

According to the Final Report by the NSF-BSR Team, the Team identified the following areas of *Best Practices*:

- General Management
- Magnet Lab Safety Awards Program to emphasize that good safety practices are valued
- Electronic safety reminder tips are continuously displayed to reinforce awareness
- Magnet Lab rewards cost savings practices and stewardship through its Cost Reduction Program
- NHMFL commissioned a study to assess the economic impact of the laboratory
- Human Resources

The NHMFL has developed a comprehensive section on Web that emphasizes the organization's commitment to encouraging diversity. According to NSF, *Best Practices* highlight the facility's operational and administrative practices, procedures and policies that *exceed* the expectations of a proficient business system and which should be shared with other NSF facilities.

The Associate Director for Management and Administration accepted invitations from the NSF to present and discuss *NHMFL Best Practices* at the *2009 and 2010 NSF Large Facilities Operations Workshop*.

Chapter 10: Science & Research Productivity

The laboratory continued its strong record of publishing, giving presentations at conferences, and advising and training students who earn Master degrees and Ph.D.s. **Table 1** summarizes these activities, and the listings follows. For additional information, refer to the Magnet Lab's Web site: www.magnet.fsu.edu (/search/publications/search.aspx), where you can search the publications database and link to many articles online. Grant information, received from Florida State University and the University of Florida's respective offices of sponsored research, is also presented in this chapter, beginning on page 155.

Table 1. 2009 Magnet Lab Activities Summary

	Number Reported	Page Number for Citations
Publications in Peer-Reviewed Journals	384	125
Presentations, Posters & Other Publications	381	139
Books, Book Chapters, Other One-time Publications	6	152
Internet Disseminations	3	153
Patents and Other Products	1	153
Awards	28	153
Dissertations, Ph.D.	27	153
Theses, Master	6	154

Of the over 380 publications reported by Magnet Lab faculty and users, 245 appeared in some of the most prominent science and major disciplinary journals (**Table 2**). The percentage of significant journal articles remains steady at 64% in 2009.

Table 2. 2009 Prominent Journal Articles

Acta Materialia	1
Analytical Chemistry	3
Angewandte Chemie International Edition	1
Applied Physics Letters	8
Biochemistry	3
Biochimica et Biophysica Acta	2
Biophysical Journal	3
Cell	1
Chemistry of Materials	2
Cryogenics	1
Energy & Fuels	4
Europhysics Letters	3
IEEE Transactions on Applied Superconductivity	17
Inorganic Chemistry	5
International Journal of Mass Spectrometry	1
Journal of Applied Physics	6
Journal of Biological Chemistry	1
Journal of Biomolecular NMR	1
Journal of Magnetic Resonance	5
Journal of Mass Spectrometry	2
Journal of Materials Research	1
Journal of Medicinal Chemistry	1
Journal of Molecular Biology	1
Journal of Physical Chemistry A	3
Journal of Physical Chemistry B	3
Journal of Physics-Condensed Matter	9
Journal of the American Chemical Society	11
Journal of the American Society for Mass Spectrometry	3
Magnetic Resonance Imaging	1
Magnetic Resonance in Chemistry	1

Magnetic Resonance in Medicine	2
Nano Letters	1
Nature	1
Nature Materials	3
Nature Methods	3
Nature Photonics	1
Nature Physics	2
Nature Structural & Molecular Biology	1
NeuroImage	2
Physical Review B	58
Physical Review B Rapid Communications	11
Physical Review Letters	36
Proceedings of the National Academy of Sciences of the United States of America	5
Protein Science	2
Rapid Communications in Mass Spectrometry	1
Science	1
Solid State Nuclear Magnetic Resonance	1
Superconductor Science and Technology	10
Total	245

PEER-REVIEWED PUBLICATIONS

This section lists over 380 articles that appeared in print in referred journals and conference proceedings in 2009. Journal titles appearing in **red boldface** are regarded by the laboratory as prominent or major disciplinary publications. To read a publication noted as [read online], go the “pubs database”:

<http://www.magnet.fsu.edu/search/publications/search.aspx>

Acelz, A.A.; Kohama, Y.; Jaime, M.; Ninios, K.; Chan, H.B.; Balicas, L.; Dabkowska, H.A. and Luke, G.M., *Bose-Einstein condensation of triplons in $Ba_3Cr_2O_8$* , **Phys. Rev. B Rapid Commun.**, **79**, 100409 (2009)

Acelz, A.A.; Kohama, Y.; Marcenat, C.; Weickert, F.; Jaime, M.; Ayala-Valenzuela, O.E.; McDonald, R.D.; Selesnic, S.D.; Dabkowska, H.A. and Luke, G.M., *Field-Induced Bose-Einstein Condensation of Triplons up to 8K in $Sr_3Cr_2O_8$* , **Phys. Rev. Lett.**, **103**, 207203 (2009) [read online]

Aguiar, M.C.; Dobrosavljevic, V.; Abrahams, E. and Kotliar, G., *Critical Behavior at the Mott-Anderson Transition: A Typical-Medium Theory Perspective*, **Phys. Rev. Lett.**, **102**, 156402 (2009) [read online]

Aharen, T.; Greedan, J.E.; Ning, F.; Imai, T.; Michaelis, V.; Kroeker, S.; Zhou, H.; Wiebe, C.R. and Cranswick, L.M.D., *Magnetic properties of the $S=3/2$ geometrically frustrated double perovskites La_2LiRuO_6 and Ba_2YRuO_6* , **Phys. Rev. B**, **80**, 134423 (2009) [read online]

Alloul, H.; Bobroff, J.; Gabay, M. and Hirschfeld, P.J., *Defects in correlated metals and superconductors*, **Reviews of Modern Physics**, **81**, 45 (2009)

Alsmadi, A.M.; Alyones, S.; Mielke, C.H.; McDonald, R.D.; Zapf, V.; Altarawneh, M.M.; Lacerda, A.; Chang, S.; Adak, S.; Kothapalli, K. and Nakotte, H., *Complex conductivity of UTX compounds in high magnetic fields*, **J. Appl. Phys.**, **105**, 07E108 (2009) [read online]

Alsmadi, M.; Alyones, S.; Mielke, C.H.; McDonald, R.D.; Zapf, V.; Altarawneh, M.M.; Lacerda, A.; Chang, S.; Adak, S.; Kothapalli, K. and Nakotte, H., *Radio-Frequency Measurements of UNiX Compounds ($X = Al, Ga, Ge$) in High Magnetic Fields*, **J. Magn. Magn. Mater.**, **321**, 3712–3718 (2009) [read online]

Altarawneh, M.M.; Mielke, C.H. and Brooks, J.S., *Proximity detector circuits: An alternative to tunnel diode oscillators for contactless measurements in pulsed magnetic field environments*, **Rev. Sci. Instrum.**, **80** (6), 066104 (2009) [read online]

Analytis, J.G.; McDonald, R.D.; Chu, J.-H.; Riggs, S.C.; Bangura, A.F.; Kucharczyk, C.; Johannes, M. and Fisher, I.R., *Quantum oscillations in the parent pnictide $BaFe_2As_2$: itinerant electrons in the reconstructed state*, **Phys. Rev. B**, **80**, 064507 (2009)

Andersen, B.M. and Hirschfeld, P.J., *Extinction of quasiparticle interference in underdoped cuprates with coexisting order*, **Phys. Rev. B**, **79**, 144515 (2009)

Andersen, B.M. and Hirschfeld, P.J., *Reply to “Comment on ‘Thermodynamic transitions in inhomogeneous d-wave superconductors’”*, **Phys. Rev. B**, **79**, 096502 (2009)

Andrade, E.C.; Miranda, E. and Dobrosavljevic, V., *Electronic Griffiths phase of the $d=2$ Mott transition*, **Phys. Rev. Lett.**, **102**, 206403 (2009) [read online]

Andrade, E.C.; Miranda, E. and Dobrosavljevic, V., *Energy-resolved spatial inhomogeneity of disordered Mott systems*, **Physica B**, **403**, 3167-3171 (2009) [read online]

Andraka, B.; Rotundu, C.; Takano, Y. and Tsujii, H., *The Dilute Limit of Heavy Fermions: Evidence of the Coherent Nature of $CeAl_3$* , **J. Phys. -Condens. Mat.**, **21**, 495601 (2009) [read online]

Antharam, V.C.; Elliott, D.W.; Mills, F.D.; Farver, R.S.; Sternin, E. and Long, J.R., *Penetration depth of surfactant peptide KL4 into membranes is determined by fatty acid saturation*, **Biophysical J.**, **96** (10), 4085-98 (2009) [read online]

- Ayala-Valenzuela, O.E.; Matutes-Aquino, J.A.; Elizalde Galindo, J.T. and Botez, C.E., *Ac susceptibility study of a magnetite magnetic fluid*, **J. Appl. Phys.**, **105** (07B524), 1063 (2009)
- Baek, S.H.; Curro, N.J.; Choi, K.Y.; Reyes, A.P.; Kuhns, P.L.; Zhou, H.D. and Wiebe, C.R., *Two inequivalent sublattices and orbital ordering in MnV_2O_4 studied by ^{51}V NMR*, **Phys. Rev. B**, **80**, 140406 (2009) [[read online](#)]
- Bai, H.; Bird, M.D.; Cantrel, K.R.; Dixon, I.R. and Gavrilin, A.V., *Design of Cryogenic System for SCH Magnets*, **IEEE Trans. Appl. Supercond.**, **19** (NO.3, June), 1596-1599 (2009)
- Baily, S.A.; Kohama, Y.; Hiramatsu, H.; Maiorov, B.; Balakirev, F.F.; Hirano, M. and Hosono, H., *Pseudoisotropic Upper Critical Field in Cobalt-Doped $SrFe_2As_2$* , **Phys. Rev. Lett.**, **102** (11), 117004 (2009) [[read online](#)]
- Balakirev, F.F.; Betts, J.B.; Migliori, A.; Tsukada, I.; Ando, Y. (Yoichi) and Boebinger, G.S., *Quantum Phase Transition in the Magnetic-Field-Induced Normal State of Optimum-Doped High-Tc Cuprate Superconductors at Low Temperatures*, **Phys. Rev. Lett.**, **102** (1), 017004 (2009) [[read online](#)]
- Baraban, M.; Zikos, G.; Bonesteel, N.E. and Simon, S.H., *Numerical Analysis of Quasiholes of the Moore-Read Wavefunction*, **Phys. Rev. Lett.**, **103**, 076801 (2009) [[read online](#)]
- Barlas, Y. and Yang, K., *Non-Fermi Liquid Behavior in Neutral Bilayer Graphene*, **Phys. Rev. B Rapid Commun.**, **80**, 161408 (2009) [[read online](#)]
- Barzykin, V. (Victor) and Gor'kov, L.P., *Role of striction at magnetic and structural transitions in iron pnictides*, **Phys. Rev. B**, **79**, 134510 (2009)
- Barzykin, V. and Pines, D., *Universal behaviour and the two-component character of magnetically underdoped cuprate superconductors*, **Adv. Physics**, **58** (1), 1-65 (2009) [[read online](#)]
- Barzykin, V., *Magnetic-field-induced gapless state in multiband superconductors*, **Phys. Rev. B**, **79** (13), 134517 (2009) [[read online](#)]
- Beattie, S.G.; Goetzman, E.; Conlon, T.; Germain, S.; Walter, G.; Campbell-Thompson, M.; Matern D.; Vockley, J. and Flotte, TR, *Biochemical correction of short-chain acyl-coenzyme a dehydrogenase deficiency after portal vein injection of rAAV8-SCAD*, **Human Gene Therapy**, **19** (6), 579-588 (2009)
- Benmelouka, M.; Van Tol, J.; Borel, A.; Nellutla, S.; Port, M.; Helm, L.; Brunel, L.C. and Merbach, A.E., *Multiple-Frequency and Variable-Temperature EPR Study of Gadolinium(III) Complexes with Polyaminocarboxylates: Analysis and Comparison of the Magnetically Dilute Powder and the Frozen-Solution Spectra*, **Helvetica Chimica Acta**, **92** (11), 2173-2185 (2009) [[read online](#)]
- Bertaina, S.; Chen, L.; Groll, N.; van Tol, J.; Dalal, N.S. and Chiorescu, I., *Multiphoton Coherent Manipulation in Large-Spin Qubits*, **Phys. Rev. Lett.**, **102** (5), 050501 (2009) [[read online](#)]
- Bhupathi, H.J. (Hwang); Martin, R.M.; Blankstein J.; Jaworski, L.; Mulders, N. and Lee, Y., *Aerogel waveguides*, **Optics Express**, **17**, 10599-10605 (2009)
- Bird, M.D.; Bai, H.; Bole, S.T.; Chen, J.; Dixon, I.R.; Ehmler, H.; Gavrilin, A.V.; Painter, T.A.; Smeibidl, P.; Toth, J.; Weijers, H.W.; Xu, T. and Zhai, Y., *The NHMFL Hybrid Magnet Projects*, **IEEE Trans. Appl. Supercond.**, **19** (NO.3, June), 1612-1616 (2009)
- Blackburn, M.E.; Veloro, A.M. and Fanucci, G.E., *Monitoring Inhibitor-Induced Conformational Population Shifts in HIV-1 Protease by Pulsed EPR Spectroscopy*, **Biochemistry**, **48**, 8765-8767 (2009)
- Boebinger, G.S., *PHYSICS An Abnormal Normal State*, **Science**, **323** (5914), 590-591 (2009)
- Botello-Zubiate, M.D.; Ayala-Valenzuela, O.E.; Matutes-Aquino, J.A. and Jaime, M., *Magnetic field-dependent resistance measurements in the superconducting ferromagnet $(Ru_{1-x}Nb_x)Sr_2Eu_{1.4}Ce_{0.6}Cu_2O_{10}$* , **J. Appl. Phys.**, **105**, 07E314 (2009)
- Botello-Zubiate, M.E.; Santillan, C.; Ayala-Valenzuela, O.E.; Matute-Aquino, J.A. and Jaime, M., *Comparative study of ferromagnetic superconductors $(Ru_{1-x}Nb_xSr_2Eu_{1.4}Ce_{0.6}Cu_2O_{10})$ by different preparation methods*, **Rev. Mex. Fis.**, **55** (1 suppl S), 118 (2009)
- Boyd, G.R.; Devereaux, T.P.; Hirschfeld, P.J.; Mishra, V. and Scalapino, D.J., *Probing the pairing symmetry of the iron pnictides with electronic Raman scattering*, **Phys. Rev. B**, **79**, 174521 (2009)
- Boyd, G.R.; Vorontsov, A.; Hirschfeld, P.J. and Vekhter, I., *Inversion of specific heat oscillations with in-plane magnetic field angle in 2D d-wave superconductors*, **Phys. Rev. B**, **79**, 064525 (2009)
- Brodbeck, J.S. and Marshall, A.G., *Report of the 24th Asilomar Conference on Mass Spectrometry*, **J. Am. Soc. Mass Spectr.**, **20**, R1 - R3 (2009)
- Buendia, G.M.; Machado, E. and Rikvold, P.A., *Effect of CO desorption and coadsorption with O on the phase diagram of a Ziff-Gulari-Barshad model for the catalytic oxidation of CO*, **J. Chem. Phys.**, **131**, 184704 (2009) [[read online](#)]
- Bussian, D.A.; Crooker, S.A.; Yin, M.; Brynda, M.; Efron, A.L. and Klimov, V.I., *Tunable magnetic exchange interactions in manganese-doped inverted core-shell ZnSe-CdSe nanocrystals*, **Nature Materials**, **8** (1), 35-40 (2009)
- Buvaylo, E.A.; Kokozay, V.N.; Vassilyeva, O.Y.; Skelton, B.W.; Eremenko, I.L.; Jezierska, J. and Ozarowski, A., *Direct Synthesis, Crystal Structure, High-Field EPR, and Magnetic Studies on an Octanuclear Heterometallic Cu(II)/Cd Complex of Triethanolamine*, **Inorg. Chem.**, **48** (23), 11092-11097 (2009) [[read online](#)]
- Cadars, S.; Smith, B.J.; Epping, J.D.; Acharya, S.; Belman, N.; Golan, Y. and Chmelka, B.F., *Atomic Positional Versus Electronic Order in Semiconducting ZnSe Nanoparticles*, **Phys. Rev. Lett.**, **103**, 136802 (2009)
- Cadden-Zimansky, P.; Wei, J. and Chandrasekhar, V., *Cooper-pair-mediated coherence between two normal metals*, **Nature Physics**, **5**, 393 (2009) [[read online](#)]
- Cadotte, A.J.; Mareci, T.H.; DeMarse, T.B.; Parekh, M.B.; Rajagovindan, R.; Ditto, W.L.; Talathi, S.S.; Hwang, D.U. and Carney, P.R., *Temporal Lobe Epilepsy: Anatomical and Effective Connectivity Temporal Lobe Epilepsy: Anatomical and Effective Connectivity*, **IEEE Trans. on Neural Systems and Rehabilitation Engineering**, **17** (3), 214-223 (2009)
- Capan, C.; Balicas, L.; Murphy, T.P.; Palm, E.C.; Movshovich, R.; Hall, D.; Tozer, S.W.; Hundley, M.F.; Bauer, E.D.; Thompson, J.D.; Sarrao, J.L.; DiTusa, J.F.; Goodrich, R.G. and Fisk, Z., *Unusual metamagnetism in $CeIrIn_5$* , **Phys. Rev. B**, **80**, 094518 (2009)
- Carson, C.G.; Hardcastle, K.; Schwartz, J.; Liu, X.; Hoffmann, C.; Gerhardt, R.A. and Tannenbaum, R., *Synthesis and Structure Characterization of Copper Terephthalate Metal-Organic Frameworks*, **Eur. J. Inorg. Chem.**, **16**, 2338-2343 (2009) [[read online](#)]

- Cason, A.M.; Kwon, B.; Smith, J.C. and Houpt, T.A., *Labyrinthectomy abolishes the behavioral and neural response of rats to a high-strength static magnetic field*, *Physiology and Behavior*, **97**, 36-43 (2009) [[read online](#)]
- Chan, W.K.; Masson, P.J.; Luongo, C.A. and Schwartz, J., *Influence of inter-layer contact resistances on quench propagation in YBa₂Cu₃O_x coated conductors*, *IEEE Trans. Appl. Supercond.*, **19** (3), 2490-2495 (2009) [[read online](#)]
- Checkelsky, J.G.; Hor, Y.S.; Liu, M.-H.; Qu, D.-X.; Cava, R.J. and Ong, N.P., *Quantum Interference in Macroscopic Crystals of Nonmetallic Bi₂Se₃*, *Phys. Rev. Lett.*, **103**, 246601 (2009) [[read online](#)]
- Checkelsky, J.G.; Li, Lu and Ong, N.P., *Divergent resistance at the Dirac point in graphene: Evidence for a transition in a high magnetic field*, *Phys. Rev. B*, **79**, 115434 (2009) [[read online](#)]
- Chekmenev, E.Y.; Vollmar, B.S. and Cotten, M., *Can antimicrobial peptides scavenge around a cell in less than a second?*, *Biochim. Biophys. Acta*, **00**, 00 (2009) [[read online](#)]
- Chen, H.; Hu, Z.-X.; Yang, K.; Rezayi, E.H. and Wan, X., *Quasiparticle tunneling in the Moore-Read fractional quantum Hall state*, *Phys. Rev. B*, **80**, 235305 (2009) [[read online](#)]
- Chen, L. and Chiorescu, I., *Coherent spin rotation in the presence of a phonon-bottleneck effect*, *Europhys. Lett.*, **87**, 57010 (2009) [[read online](#)]
- Chen, W. and Hirschfeld, P.J., *Effect of oxygen chain defects on NMR response in YBCO*, *Phys. Rev. B*, **79**, 064522 (2009)
- Chen, W.; Andersen, B.M. and Hirschfeld, P.J., *Theory of Resistivity Upturns in Metallic Cuprates*, *Phys. Rev. B*, **80**, 134518 (2009)
- Chen, Z.; Kametani, F.; Chen, Y.; Xie, Y.; Selvamanickam, V. and Larbalestier, D.C., *A high critical current density MOCVD coated conductor with strong vortex pinning centers suitable for very high field use*, *Superconductor Science and Technology*, **22**, 055013 (2009) [[read online](#)]
- Chen, Z.J.; Kametani, F.; Gurevich, A. and Larbalestier, D.C., *Pinning, thermally activated depinning and their importance for tuning the nanoprecipitate size and density in high Jc YBa₂Cu₃O_{7-δ} films*, *Physica C*, **469**, 2021-2028 (2009)
- Cheng, M.; Glossop, M.T. and Ingersent, K., *Quantum phase transitions in a charge-coupled Bose-Fermi Anderson model*, *Phys. Rev. B*, **80**, 165113 (2009)
- Chiatti, O.; Zherlitsyn, S.; Sytcheva, A.; Wosnitza, J.; Zvyagin, A.A.; Zapf, V.S.; Jaime, M. and Paduan-Filho, A., *Ultrasonic investigation of NiCl₂-4SC(NH₂)₂*, *J. Phys.: Conf. Series*, **150**, 042016 (2009)
- Cho, K.; Smith, B.E.; Coniglio, W.A.; Winter, L.E.; Agosta, C.C. and Schlueter, J.A., *Upper critical field in the organic superconductor beta''-(ET)₂SF₃CH₂CF₂SO₃: Possibility of Fulde-Ferrell-Larkin-Ovchinnikov state*, *Phys. Rev. B Rapid Commun.*, **79**, 220507 (2009) [[read online](#)]
- Cimberle, M.R.; Canepa, F.; Ferretti, M.; Martinelli, A.; Palenzona, A.; Siri, A.S.; Tarantini, C.; Tropeano, M. and Ferdeghini, C., *Magnetic characterization of undoped and 15%F doped LaFeAsO and SmFeAsO compounds*, *J. Magn. Magn. Mater.*, **321** (19), 3024-3030 (2009) [[read online](#)]
- Coldea, A.I.; Andrew, C.M.; Analytis, J.G.; McDonald, R.D.; Bangura, A.F.; Chu, J.-H.; Fisher, I.R. and Carrington, A., *Topological Change of the Fermi Surface in Ternary Iron Pnictides with Reduced c/a Ratio: A de Haas-van Alphen Study of CaFe₂P₂*, *Phys. Rev. Lett.*, **103**, 026404 (2009) [[read online](#)]
- Constantinidis, I.; Grant, S.C.; Simpson, N.E.; Oca-Cossio, J.A.; Sweeney, C.A.; Mao, H.; Blackband, S.J. and Sambanis, A., *Use of magnetic nanoparticles to monitor alginate-encapsulated bTC-tet cells*, *Magnet. Reson. Med.*, **61**, 282-290 (2009)
- Cooley, B.J.; Clark, T.E.; Liu, B.Z.; Eichfeld, C.M.; Dickey, E.C.; Mohny, S.E.; Crooker, S.A. and Samarth, N., *Growth of magneto-optically active (ZnMn)Se nanowires*, *Nano Letters*, **9**, 3142 (2009)
- Copping, R.; Talbot-Eckelaers, C.; Collision, D.; Helliwell, M.; Gaunt, A.J.; May, I.; Reilly, S.D.; Scott, B.L.; McDonald, R.D.; Ayala-Valenzuela, O.; Jones, J.C. and Sarsfield, M.J., *Probing the 5f electrons in a plutonyl(VI) cluster complex*, *Dalton Trans. Chem.*, **10** (1039), 908648 (2009)
- Crooker, S.A. and Samarth, N., *Tuning magnetic disorder in diluted magnetic semiconductors using high fields to 89 tesla*, *Int. J. Mod. Phys. B*, **23**, 2575 (2009) [[read online](#)]
- Crooker, S.A.; Cheng, L. and Smith, D.L., *Spin noise of conduction electrons in n-type bulk GaAs*, *Phys. Rev. B*, **79**, 035208 (2009) [[read online](#)]
- Crooker, S.A.; Garlid, E.S.; Chantis, A.N.; Smith, D.L.; Reddy, K.S.M.; Hu, Q.O.; Kondo, T.; Palmstrom, C.J. and Crowell, P.A., *Bias-controlled sensitivity of ferromagnet-semiconductor electrical spin detectors*, *Phys. Rev. B Rapid Commun.*, **80**, 041305 (2009) [[read online](#)]
- Cross, T.A., *Flu M2B Structure and Function*, *Nature Struct. Mol. Biol.*, **16**, 1207-1209 (2009)
- Cui, H.; Brooks, J.S.; Kobayashi, A. and Hobayashi, H., *Metallization of the Single Component Molecular Semiconductor [Ni(ptdt)(2)] under Very High Pressure*, *J. Am. Chem. Soc.*, **131** (18), 6358 (2009)
- Cui, H.B.; Graf, D.; Brooks, J.S. and Kobayashi, H., *Pressure-Dependent Metallic and Superconducting Phases in a Germanium Artificial Metal*, *Phys. Rev. Lett.*, **102**, 237001-5 (2009)
- Dai, Yanhua; Yuan, Z.Q.; Yang, C.L.; Du, R.R.; Manfra, M.J.; Pfeiffer, L.N. and West, K.W., *Magnetotransport in Zener tunneling regime in a high-mobility two-dimensional hole gas*, *Phys. Rev. B Rapid Commun.*, **80**, 041310 (2009)
- Dalisay, D.S.; Rogers, E.W.; Edison, A.S. and Molinski, T.F., *Structure Elucidation at the Nanomole-Scale. Trisoxazole macrolides and Thiazole-containing cyclic peptides from the Nudibranch Hexabanchus sanguineus*, *J. Natural Products*, **72**, 732-8 (2009)
- Danielson, L.R.; Richter, K. and Humayun, M., *Trace element chemistry of Cumulus Ridge 04071 pallasite with implications for main group pallasites*, *Meteoritics & Planetary Sciences*, **44**, 1019-1032 (2009) [[read online](#)]
- Daou, R.; Leyraud, N.D.; LeBoeuf, D.; Li, S.; Laliberté, F.; Cyr-Choinière, O.; Jo, Y.J.; Balicas, L.; Yan, J.-Q.; Zhou, J.-S.; Goodenough, J.B. and Taillefer, L., *Linear temperature dependence of resistivity and change in the Fermi surface at the pseudogap critical point of a high-Tc superconductor*, *Nature Physics*, **5**, 31 (2009)
- Das Sarma, S. and Yang, K., *The enigma of the nu=0 quantum Hall effect in graphene*, *Solid State Commun.*, **149**, 1502 (2009) [[read online](#)]
- Das, R.; Salters, V.J.M. and Odom, A.L., *A case for in vivo mass-independent fractionation of mercury isotopes in fish*, *Geochemistry, Geophysics, Geosystems*, **10** (11), Q11012 (2009)

- Datta, S.; Bolin, E.; Milios, C.J.; Brechin, E.K. and Hill, S., *A comparative EPR study of high- and low-spin Mn₂ single molecule magnets*, **Polyhedron**, **28**, 1911-1916 (2009) [[read online](#)]
- Davidson, M.W. and Campbell, R.E., *Engineered fluorescent proteins: innovations and applications*, **Nature Methods**, **6** (10), 713-717 (2009) [[read online](#)]
- Davidson, M.W., *Fluorescence Spectroscopy: Alexander Jablonski*, **American Society for Clinical Pathology | LabMedicine**, **40** (11), 52-53 (2009) [[read online](#)]
- Davidson, M.W., *Microscopy Pioneers: Zacharias Janssen and Johannes Kepler*, **Microscopy Today**, **17** (11), 66-67 (2009) [[read online](#)]
- Davidson, M.W., *Microscopy: Ernst Abbe*, **American Society for Clinical Pathology | LabMedicine**, **40** (8), 502-503 (2009) [[read online](#)]
- Davidson, M.W., *Pioneers in Optics: Ernst Abbe*, **Microscopy Today**, **17** (1), 38-42 (2009) [[read online](#)]
- Davidson, M.W., *Pioneers in Optics: Henry Baker and Giovanni Borelli*, **Microscopy Today**, **17** (8), 64-65 (2009) [[read online](#)]
- Davidson, M.W., *Pioneers in Optics: Pierre de Fermat and Sir George Biddell Airy*, **Microscopy Today**, **17** (9), 56-57 (2009) [[read online](#)]
- Day, R.N. and Davidson, M.W., *The fluorescent protein palette: tools for cellular imaging*, **Chemical Society Reviews**, **28**, 2887-2921 (2009) [[read online](#)]
- Day, R.N.; Sun, Y.; Booker, C.F.; Kumari, S.; Periasamy, A. and Davidson, M.W., *The characterization of optimized fluorescent proteins for Forster resonance energy transfer microscopy*, **Proc. SPIE**, **7183**, 718306 (2009) [[read online](#)]
- del Barco, E.; Hill, S. and Hendrickson, D.N., *Comment on "Influence of the Dzyaloshinskii-Moriya exchange interaction on quantum phase interference of spins"*, **Phys. Rev. Lett.**, **103**, 059701 (2009) [[read online](#)]
- Dias da Silva, L.G.G.V.; Sandler, N.; Simon, P.; Ingersent, K. and Ulloa, S.E., *Tunable pseudogap Kondo effect and quantum phase transitions in Aharonov-Bohm interferometers*, **Phys. Rev. Lett.**, **102**, 166806 (2009)
- Ding, W. and Yang, K., *Entanglement Entropy and Mutual Information in Bose-Einstein Condensates*, **Phys. Rev. A**, **80**, 012329 (2009) [[read online](#)]
- Dixon, I.R.; Bird, M.D.; Bonito-Oliva, A.; Cantrell, K.R.; Lu, J.; Miller, G.E.; Noyes, P.D.; Walsh, R.P. and Weijers, H.W., *Electromagnetic Cycling and Strain Effects on N₃Sn Cable-In-Conduit Conductors with Variations in Cabling Design and Conduit Materials*, **IEEE Trans. Appl. Supercond.**, **19** (3), 1462-1465 (2009)
- Dixon, I.R.; Bird, M.D.; Bruzzone, P.; Gavrilin, A.V.; Lu, J.; Stepanov, B. and Weijers, H.W., *Current Sharing and AC Loss Measurements of a Cable-in-Conduit Conductor with Nb₃Sn Strands for the High Field Section of the Series-Connected Hybrid Outsert Coil*, **IEEE Trans. Appl. Supercond.**, **19** (NO.3, June), 2466-2469 (2009)
- Dong, G.C.; Chung, P.H.; Chang, K.C.; Jan, P.S.; Hwang, P.I.; Wu, H.B.; Yi, M.; Zhou, H.X. and Chen, H.M., *Blocking effect of an immunosuppressive agent, Cynarin, on CD28 of T-cell receptor*, **Pharmaceutical Research**, **26**, 375-381 (2009) [[read online](#)]
- Dordevic, S.V.; Kohlman, L.W.; Tung, L.C.; Wang, Y.-J.; Gozar, A.; Logvenoc, G. and Bozovic, I., *Absence of magnetic-field-induced effects in the mid-infrared transmission of La_{2-x}Sr_xCuO₄ thin films*, **Phys. Rev. B**, **79**, 134503-1 (2009)
- Dossey, A.T.; Gottardo, M.; Whitaker, J.; Roush, W.R. and Edison, A.S., *Alkyldimethylpyrazines in the Defensive Spray of Phyllium westwoodii: A First for Order Phasmatodea*, **J. Chem. Ecol.**, **35** (8), 861-870 (2009) [[read online](#)]
- Drichko, I.L.; Dyakonov, A.M.; Smirnov, I.Yu.; Suslov, A.V.; Galperin, Y.M.; Vinokur, V.; Myronov, M. and Mironov, O.A., *Wigner glass formation in 2DHG of p-Si/SiGe by high magnetic fields*, **J. Phys.: Conf. Series**, **150**, 022010 (2009)
- Drichko, I.L.; Smirnov, I.Yu.; Suslov, A.V.; Mironov, O.A. and Leadley, D.R., *Large magnetoresistance of a dilute p-Si/SiGe/Si quantum well in a parallel magnetic field*, **Phys. Rev. B**, **79** (20), 205310 (2009)
- Drichko, I.L.; Smirnov, I.Yu.; Suslov, A.V.; Mironov, O.A. and Leadley, D.R., *Magnetoresistance in dilute p-Si/SiGe in parallel and tilted magnetic fields*, **Annalen der Physik**, **18** (12), 939 (2009)
- Edison, A.S., *C. elegans Pheromones Regulate Multiple Complex Behaviors*, **Current Opinion in Neurobiology**, **19** (4), 378-388 (2009)
- Eichel, R.-A.; Erunal, E.; Drahus, M.; Smyth, D.; van Tol, J.; Acker, J.; Kungl, H. and Hoffmann, M., *Local variations in defect polarization and covalent bonding in ferroelectric Cu²⁺-doped PZT and KNN functional ceramics at the morphotropic phase boundary*, **Phys. Chem. Chem. Phys.**, **11**, 8698-8705 (2009) [[read online](#)]
- Eisterer, M.; Weber, H.W.; Jiang, J.; Weiss, J.D.; Yamamoto, A.; Polyanskii, A.A.; Hellstrom, E.E. and Larbalestier, D.C., *Neutron Irradiation of SmFeAsO_{1-x}F_x*, **Superconductor Science and Technology**, **22**, 065015 (2009) [[read online](#)]
- Eisterer, M.; Zehetmayer, M.; Weber, H.W.; Jiang, J.; Weiss, J.D.; Yamamoto, A. and Hellstrom, E.E., *Effects of disorder on the superconducting properties of BaFe_{1.8}Co_{0.2}As₂ single crystals*, **Superconductor Science and Technology**, **22** (9), 095011 (2009) [[read online](#)]
- Fauqué, B.; Yang, H.; Sheikin, I.; Balicas, L.; Issi, J-P and Behnia, K., *Hall plateaus at magic angles in bismuth beyond the quantum limit*, **Phys. Rev. B**, **79**, 245124 (2009)
- Feiguin, A.E.; Rezayi, E.; Yang, K.; Nayak, C. and Das Sarma, S., *Spin polarization of the nu=5/2 quantum Hall state*, **Phys. Rev. B**, **79**, 115322 (2009) [[read online](#)]
- Feng, P.L.; Koo, C.; Henderson, J.; Manning, P.; Nakano, M.; del Barco, E.; Hill, S. and Hendrickson, D.N., *Nanomodulation of Molecular Nanomagnets*, **Inorg. Chem.**, **48**, 3480-3492 (2009) [[read online](#)]
- Flint, J.; Hansen, B.; Vertegaard-Poulsen, P. and Blackband, S.J., *Diffusion weighted magnetic resonance imaging of neuronal activity in the hippocampal slice model*, **Neuroimage**, **46** (2), 411-418 (2009)
- Flint, J.J.; Lee, C.H.; Hansen, B.; Fey, M.; Schmidig, D.; Bui, J.D.; King, M.A.; Vestergaard-Poulsen, P. and Blackband, S.J., *Magnetic resonance microscopy of mammalian neurons*, **Neuroimage**, **46** (4), 1037-1040 (2009)
- Fortune, N.A.; Hannahs, S.T.; Yoshida, Y.; Sherline, T.E.; Ono, T.; Tanaka, H. and Takano, Y., *Cascade of Magnetic-Field-Induced Quantum Phase Transitions in a Spin-1/2 Triangular-Lattice Antiferromagnet*, **Phys. Rev. Lett.**, **102**, 257201 (2009) [[read online](#)]

- Foyevtsova, K.; Valenti, R. and Hirschfeld, P.J., *Effect of dopant atoms on local superexchange in cuprate superconductors: a perturbative treatment*, **Phys. Rev. B**, **79**, 144424 (2009)
- Frank, M.P.; Oniciuc, L.; Meyer-Baese, U.H. and Chiorescu, I., *A space-efficient quantum computer simulator suitable for high-speed FPGA implementation*, **Proc. SPIE Int. Soc. Opt. Eng.**, **7342**, 7342-03-1-12 (2009) [[read online](#)]
- Frantom, P.A.; Zhang, H.-M.; Emmett, M.R.; Marshall, A.G. and Blanchard, J.S., *Mapping of the Allosteric Network in the Regulation of α -Isopropylmalate Synthase from *Mycobacterium tuberculosis* by the Feedback Inhibitor L-Leucine: Solution-Phase H/D Exchange Monitored by FT-ICR Mass Spectrometry*, **Biochemistry**, **48**, 7457-7464 (2009)
- Frommer, W.B.; Davidson, M.W. and Campbell, R.E., *Genetically encoded biosensors based on engineered fluorescent proteins*, **Chemical Society Reviews**, **38**, 2833-2841 (2009) [[read online](#)]
- Fu, R., *Efficient Heteronuclear Dipolar Decoupling in NMR of Static Solid Samples using Phase-Wiggled Two-Pulse Phase Modulation*, **Chem. Phys. Lett.**, **483**, 147-153 (2009)
- Fu, R.; Brey, W.W. and Cross, T.A., *Aligned Membrane Proteins: Structural Studies*, **Encyclopedia of Magnetic Resonance**, Eds. R.K. Harris & R.E. Wasylshen, John Wiley, Chichester (2009)
- Fu, R.; Gordon, E.D.; Hibbard, D.J. and Cotten, M., *High resolution heteronuclear correlation NMR spectroscopy of an aligned antimicrobial peptide: Direct evidence of spectral enhancement at high magnetic field and peptide-water interactions at the water-bilayer interface*, **J. Am. Chem. Soc.**, **131**, 10830-10831 (2009)
- Gaboardi, M. and Humayun, M., *Elemental fractionation during LA-ICP-MS analysis of silicate glasses: implications for matrix-independent standardization*, **J. Analytical Atomic Spectrometry**, **24**, 1188-1197 (2009) [[read online](#)]
- Gajiwala, K.S.; Wu, J.C.; Christensen, J.; Deshmukh, G.D.; Diehl, W.; DiNitto, J.P.; English, J.M.; Greig, M.; He, Y.-A.; Jacques, S.L.; Lunney, E.A.; McTigue, M.; Molina, D.; Quenzer, T.A.; Wells, P.A.; Yu, X.; Zhang, Y.; Zou, A.; Emmett, M.R.; Marshall, A.G.; Zhang, H.-M. and Demetri, G., *KIT Kinase Mutants Show Unique Mechanisms of Drug Resistance to Imatinib and Sunitinib in Gastrointestinal Stromal Tumor Patients*, **P. Natl. Acad. Sci. U.S.A.**, **106**, 1542-1547 (2009)
- Galiano, L.; Blackburn, M.E.; Voloro, A.M.; Bonora, M. and Fanucci, G.E., *Solute Effects on Spin Labels at an Aqueous-Exposed Site in the Flap Region of HIV-1 Protease*, **J. Phys. Chem. B**, **113** (6), 1673-1680 (2009)
- Galiano, L.; Ding, F.; Voloro, A.M.; Blackburn, M.E.; Simmerling, C. and Fanucci, G.E., *Drug Pressure Selected Mutations in HIV-1 Protease Alter Flap Conformations*, **J. Am. Chem. Soc.**, **131** (2), 430-431 (2009) [[read online](#)]
- Gan, Z.; Gor'kov, P.L.; Brey, W.W.; Sideris, P.J. and Grey, C.P., *Enhancing MQMAS of low-gamma nuclei by using a high B1 field balanced probe circuit*, **J. Magn. Reson.**, **200**, 2-5 (2009) [[read online](#)]
- Gapud, A.A.; Moraes, S.; Khadka, R.P.; Favreau, P.; Henderson, C.; Canfield, P.C.; Kogan, V.G.; Reyes, A.P.; Lumata, L.L.; Christen, D.K. and Thompson, J.R., *Flux quanta driven by high-density currents in low-impurity V_3Si and $LuNi_2B_2C$: Free flux flow and fluxon-core size effect*, **Phys. Rev. B**, **80**, 134524 (2009) [[read online](#)]
- Gardino, A.K.; Villali, J.; Kinvenson, A.; Lei, M.; Liu, C.; Steindel, P.; Eisenmesser, E.; Labeikovskiy, W.; Wolf-Watz, M.; Clarkson, M. and Kern, D., *Transient Non-Native Hydrogen Bonds Promote Activation of a Signaling Protein*, **Cell**, **139**, 1109-1118 (2009)
- Gokmen, T.; Padmanabhan, M.; Vakili, K.; Tutuc, E. and Shayegan, M., *Effective mass suppression upon complete spin-polarization in an isotropic two-dimensional electron system*, **Phys. Rev. B**, **79**, 195311 (2009) [[read online](#)]
- Graf, D.; Brooks, J.S.; Almeida, M.; Dias, J.C.; Uji, S.; Terashima, T. and Kimata, M., *Evolution of superconductivity from a charge-density-wave ground state in pressurized $(Per)_2[Au(mnt)]_2$* , **Europhys. Lett.**, **85** (2), 27009 (2009) [[read online](#)]
- Graf, D.; Brooks, J.S.; Choi, E.S.; Almeida, M.; Henriques, R.T.; Dias, J.C. and Uji, S., *Geometrical and orbital effects in a quasi-one-dimensional conductor*, **Phys. Rev. B**, **80** (15), 155104 (2009)
- Graf, D.; Stillwell, R.; Murphy, T.P.; Park, J.-H.; Kano, M.; Palm, E.C.; Schlottmann, P.; Bourg, J.; Collar, K.N.; Cooley, J.C.; Lashley, J.C.; Willit, J. and Tozer, S.W., *Fermi surface of alpha-uranium at ambient pressure*, **Phys. Rev. B Rapid Commun.**, **80**, 241101 (2009)
- Graser, S.; Hirschfeld, P.J.; Maier, T. and Scalapino, D.J., *Near-degeneracy of several pairing channels in multiorbital models for the Fe-pnictides*, **New Journal of Physics**, **11**, 025016 (2009)
- Groll, N.; Bertaina, S.; Pati, M.; Dalal, N.S. and Chiorescu, I., *Entrapment of magnetic microcrystals for on-chip electron spin resonance studies*, **J. Appl. Phys.**, **106** (4), 046106 (2009) [[read online](#)]
- Grove, C.M.; Dixon, P.J. and Pop, M.M., *Research experiences for teachers: influences related to expectancy and value of changes to practice in the American classroom*, **Professional Development in Education**, **35** (2), 247-260 (2009) [[read online](#)]
- Haapala, M.; Purcell, J.M.; Saarela, V.; Franssila, S.; Rodgers, R.P.; Hendrickson, C.L.; Kotiaho, T.; Marshall, A.G. and Kostianen, R., *Microchip Atmospheric Pressure Photoionization for Analysis of Petroleum by Fourier Transform Ion Cyclotron Resonance Mass Spectrometry*, **Anal. Chem.**, **81**, 2799-2803 (2009)
- Hall, D.; Balicas, L.; Fisk, Z.; Goodrich, R.G.; Alver, U. and Sarrao, J.L., *High-field de Haas-van Alphen studies of the Fermi surfaces of $LaMn_3$ ($M=Co, Rh, Ir$)*, **Phys. Rev. B**, **79**, 033106 (2009)
- Hamidane, H.B.; He, H.; Tsybin, O.Yu.; Emmett, M.R.; Hendrickson, C.L.; Marshall, A.G. and Tsybin, Y.O., *Periodic Sequence Distribution of Product Ion Abundances in Electron Capture Dissociation of Amphipathic Peptides and Proteins*, **J. Mass Spectrometry**, **20**, 1182-1192 (2009)
- Han, K.; Xin, Y.; Walsh, R.P.; Downey, S. and Kalu, P.N., *The effects of grain boundary precipitates on cryogenic properties of aged 316-type stainless steels*, **Materials Science and Engineering A - Structural Materials Processing Microstructure and Processing**, **516**, 169-179 (2009) [[read online](#)]
- Hazelton, D.W.; Selvamanickam, V.; Duval, J.M.; Larbalestier, D.C.; Markiewicz, W.D.; Weijers, H.W. and Holtz, R.L., *Recent Developments in 2G HTS Coil Technology*, **IEEE Trans. Appl. Supercond.**, **19** (3), 2218-2222 (2009)

- Headley, J.V.; Peru, K.M.; Armstrong, S.; Han, X.; Martin, J.W.; Mapolelo, M.M.; Smith, D.F.; Rodgers, R.P. and Marshall, A.G., *Comparison of Aquatic Plant Derived Changes in Aqueous Naphthenic Acid Profiles Determined by ESI/MS, HPLC/QTOF MS and FT-ICR MS*, **Rapid Commun. Mass Sp.**, **23**, 515-522 (2009)
- Hemmati, A.M.; Fuzier, S.; Bosque, E. and Van Sciver, S.W., *Drag measurements on an oscillating sphere in helium II*, **J. Low Temp. Phys.**, **156** (3/4-5/6), 71 (2009)
- Henderson, J.J.; del Barco, E.; Koo, C.; Hill, S.; Feng, P.L. and Hendrickson, D.N., *Manifestation of Spin Selection Rules on the Quantum Tunneling of Magnetization in a Single Molecule Magnet*, **Phys. Rev. Lett.**, **103**, 017202 (2009) [[read online](#)]
- Hendrickson, C.L.; Beu, S.C.; Blakney, G.T. and Marshall, A.G., *SIMION Modeling of Ion Image Charge Detection in Fourier Transform Ion Cyclotron Resonance Mass Spectrometry*, **Int. J. Mass Spectrom.**, **283**, 100-104 (2009)
- Hill, S.; Murugesu, M. and Christou, G., *Anisotropy barrier reduction in fast-relaxing Mn_{12} single-molecule magnets*, **Phys. Rev. B**, **80**, 174416 (2009) [[read online](#)]
- Hirschfeld, P.J., *Nodes to the grindstone: viewpoint on 'Band- and momentum-dependent electron dynamics in superconducting $Ba(Fe_{1-x}Co_x)_2As_2$ as seen via electronic Raman scattering'*, by Muschler et al., **Physics**, **2**, 100 (2009)
- Hoch, M.J.R.; Kuhns, P.L.; Moulton, W.G.; Lu, J.; Reyes, A.P. and Mitchell, J.F., *Non-Korringa nuclear relaxation in the ferromagnetic phase of the bilayered manganite $La_{1.2}Sr_{1.8}Mn_2O_7$* , **Phys. Rev. B**, **80**, 024413 (2009) [[read online](#)]
- Hoch, M.J.R.; Nellutla, S.; van Tol, J.; Choi, E.S.; Lu, J.; Zheng, H. and Mitchell, J.F., *Diamagnetic to paramagnetic transition in $LaCoO_3$* , **Phys. Rev. B**, **79**, 214421 (2009)
- Hockaday, W.C.; Purcell, J.M.; Marshall, A.G.; Baldock, J.A. and Hatcher, P.G., *Electrospray and Photoionization Mass Spectrometry for the Characterization of Organic Matter in Natural Waters: A Qualitative Assessment*, **Limnology and Oceanography: Methods**, **7**, 81-95 (2009)
- Hormozi, L.; Bonesteel, N.E. and Simon, S.H., *Topological Quantum Computing with Read-Rezayi States*, **Phys. Rev. Lett.**, **103** (16), 160501 (2009) [[read online](#)]
- Htoon, H.; Crooker, S.A.; Furis, M.; Jeong, S.; Efros, A.I. and Klimov, V.I., *Anomalous circular polarization of photoluminescence spectra of individual CdSe nanocrystals in an applied magnetic field*, **Phys. Rev. Lett.**, **102**, 017402 (2009)
- Hu, J.; Sharma, M.; Qin, H.J.; Gao, F.P. and Cross, T.A., *Ligand Binding in the Conserved Interhelical Loop of CorA, a Magnesium Transporter from Mycobacterium tuberculosis*, **J. Biol. Chem.**, **284** (23), 15619-15628 (2009)
- Hu, Z.-X.; Rezayi, E. H.; Wan, X. and Yang, K., *Edge-mode velocities and thermal coherence of quantum Hall interferometers*, **Phys. Rev. B**, **80**, 235330 (2009) [[read online](#)]
- Huan, C.; Kim, S.S.; Phelps, L.; Xia, J.S.; Candela, D. and Sullivan, N.S., *A Novel Design of a Low Temperature Preamplifier for Pulsed NMR Experiments of Dilute 3He in Solid 4He* , **J. Low Temp. Phys.**, **Online**, - (2009) [[read online](#)]
- Huang, S.; Abouchami, W.; Blichert-Toft, J.; Clague, D.A.; Cousens, B. L.; Frey, F. A. and Humayun, M., *Ancient carbonate sedimentary signature in the Hawaiian plume: evidence from Mahukona volcano, Hawaii*, **Geochemistry, Geophysics, Geosystems**, **10**, Q08002 (2009) [[read online](#)]
- Huber, T.E.; Nikolaeva, A.; Konopko L. and Graf, M.J., *Observation of three-dimensional behavior in surface states of bismuth nanowires and the evidence for bulk-Bi surface quasiparticles*, **Phys. Rev. B Rapid Commun.**, **79**, 201304 (2009)
- Humayun, M., *2009 Leonard Medal for Lawrence Grossman.*, **Meteoritics & Planetary Science**, **44**, A5-A6 (2009)
- Hung, I.; Shetty, K.K.; Ellis, P.D.; Brey, W.W. and Gan, Z.H., *High-field QCPMG NMR of large quadrupolar patterns using resistive magnets*, **Solid State Nucl. Mag. Reson.**, **36**, 159-163 (2009) [[read online](#)]
- Hung, I.; Trebosc, J.; Hoatson, G.L.; Vold, R.L.; Amoureux, J.P. and Gan, Z.H., *Q-shear transformation for MQMAS and STMAS NMR spectra*, **J. Magn. Reson.**, **201** (1), 81-86 (2009)
- Inglis, R.; Jones, L.F.; Milios, C.J.; Datta, S.; Collins, A.; Parsons, S.; Wernsdorfer, W.; Hill, S.; Perlepes, S.P.; Piligkos S. and Brechin, E.K., *Attempting to Understand (and Control) the Relationship between Structure and Magnetism in an Extended Family of Mn_6 Single-Molecule Magnets*, **Dalton Trans. Chem.**, **2009**, 3403-3412 (2009) [[read online](#)]
- Inglis, R.; Milios, C.J.; Jones, L.F.; Mason, K.; Papaefstathiou, G.S.; Perlepes, S.P.; Datta, S.; Hill, S.; Wernsdorfer, W. and Brechin, E.K., *Twisting, Bending, Stretching: Strategies for Making Ferromagnetic $[Mn^{III}_3]$ Triangles*, **Dalton Trans. Chem.**, **2009**, 9157-9168 (2009) [[read online](#)]
- Jain, P.; Ramachandran, V.; Clark, R.J.; Zhou, H.D.; Toby, B.H.; Dalal, N.S.; Kroto, H.W. and Cheetham, A.K., *Multiferroic behavior associated with an order-disorder hydrogen bonding transition in metal-organic frameworks (MOFs) with the perovskite ABX_3 architecture*, **J. Am. Chem. Soc.**, **131**, 13625-13627 (2009) [[read online](#)]
- Janik, J.A.; Zhou, H.D.; Jo, Y.J.; Balicas, L.; Macdougall, G.J.; Luke, G.M.; Garrett, J.D.; McClellan, K.J.; Bauer, E.D.; Sarrao, J.L.; Qiu, Y.; Copley, J.R.D.; Buyers, W.J.L. and Wiebe, C.R., *Itinerant spin excitations near the hidden-order transition in URu_2Si_2* , **J. Phys. -Condens. Mat.**, **21**, 192202 (2009) [[read online](#)]
- Jaroszynski, J. and Popovic, D., *Aging and Memory in a Two-Dimensional Electron System in Si*, **Physica B**, **404**, 466 (2009)
- Jeona, K.; Palza, H.; Quijada, R. and Alamo, R.G., *Effect of Comonomer Type on the Crystallization Kinetics of Random Isotactic Propylene 1-Alkene Copolymers*, **Polymer**, **50** (3), 832-844 (2009) [[read online](#)]
- Jin, Z.; Zhang, L.; Wang, Y.; Cui, Y. and Milla, K., *Using carbon, hydrogen and helium isotopes to unravel the origin of hydrocarbons in the Wujiaweizi area of the Songliao Basin, China*, **Episodes**, **32**, 167-176 (2009)
- Jo, Y.J.; Jaroszynski, J.; Yamamoto, A.; Gurevich, A.; Riggs, S.C.; Boebinger, G.S.; Larbalestier, D.; Wen, H.H.; Zhigadlo, N.D.; Katrych, S.; Bukowski, Z.; Karpinski, J.; Liu, R.H.; Chen, H.; Chen, X.H. and Balicas, L., *High-field phase-diagram of Fe arsenide superconductors*, **Physica C**, **469**, 566 (2009)
- Jo, Y.J.; Lee, S.; Choi, E.S.; Yi, H.T.; Ratcliff, W.; Choi, Y.J.; Kiryukhin, V.; Cheong, S.W. and Balicas, L., *3:1 magnetization plateau and suppression of ferroelectric polarization in an Ising chain multiferroic*, **Phys. Rev. B**, **79**, 012407 (2009) [[read online](#)]

- Junior, A.F.; Alves, T.E.P.; Lima, E.C. de O.; Nunes, E. da S. and Zapf, V.S., *Enhanced magnetization of nanoparticles of $Mg_xFe_{3-x}O_4$ ($0.5 \leq x \leq 1.5$) synthesized by combustion reaction*, *Appl. Physics A: Materials Science and Processing*, **94**, 131 (2009)
- Kametani, F.; Li, P.; Abrahimov, D.; Polyanskii, A.A.; Yamamoto, A.; Jiang, J.; Hellstrom, E.E.; Gurevich, A.; Larbalestier, D.C.; Ren, Z.A.; Yang, J.; Dong, X.L.; Lu, X. and Zhao, Z.X., *Intergrain current flow in a randomly oriented polycrystalline $SmFeAsO_{0.85}$ oxypnictide*, *Appl. Phys. Lett.*, **95**, 142502 (2009)
- Kametani, F.; Polyanskii, A.A.; Yamamoto, Y.; Jiang, J.; Hellstrom, E.E.; Gurevich, A.; Larbalestier, D.C.; Ren, Z.A.; Yang, J.; Dong, X.L. and Zhao, Z.X., *Combined microstructural and magneto-optical study of current flow in polycrystalline forms of Nd and Sm Fe-oxypnictides*, *Superconductor Science and Technology*, **22**, 015010 (2009) [[read online](#)]
- Kandimalla, K.K.; Olenych, G.S.; Fulzele, S.; Davidson, M.W. and Poduslo, J.F., *Mechanism of Neuronal versus Endothelial Cell Uptake of Alzheimer's Disease Amyloid beta-Protein*, *PLoS Biology*, **4** (2), e4627 (2009) [[read online](#)]
- Kang, W.; Jo, Y.J.; Noh, D.Y.; Son, K.I. and Chung, O.H., *Stereoscopic study of angle-dependent interlayer magnetoresistance in the organic conductor $k-(BEDT-TTF)_2Cu(NCS)_2$* , *Phys. Rev. B*, **80** (15), 155102 (2009)
- Kano, M.; Kohama, Y.; Graf, D.; Balakirev, F.; Sefat, A.S.; Mcguire, M.A.; Sales, B.C.; Mandrus, D. and Tozer, S.W., *Anisotropy of the Upper Critical Field in a Co-Doped $BaFe_2As_2$ Single Crystal*, *J. Phys. Soc. Japan*, **78**, 084719 (2009) [[read online](#)]
- Kano, M.; Mori, H.; Uwatoko, Y. and Tozer, S.W., *Anisotropy of the upper critical field in ultrahigh-pressure-induced superconductor $(TMTTF)_2PF_6$* , *Physica B*, **404** (19), 3246-3248 (2009) [[read online](#)]
- Kano, M.; Uchiyama, K.; Taniguchi, H.; Hedo, M.; Matsubayashi, K. and Uwatoko, Y., *Superconductivity induced by extremely high pressures in organic Mott-insulator $\beta'-(BEDT-TTF)_2BrCl$* , *J. Phys.: Conf. Series*, **150**, 052093 (2009) [[read online](#)]
- Kaplan, F.; Badri, D.V.; Zachariah, C.; Ajredini, R.; Sandoval, F.J.; Roje, S.; Levine, L.H.; Zhang, F.; Robinette, S.L.; Alborn, H.T.; Zhao, W.; Stadler, M.; Nimalendran, R.; Dossey, A.T.; Bruschweiler, R.A.; Vivanco, J.M. and Edison, A.S., *Bacterial Attraction and Quorum Sensing Inhibition in *Caenorhabditis elegans* Exudates*, *Chem. Ecol.*, **35**, 878-892 (2009)
- Kear, J.L.; Blackburn, M.E.; Veloro, A.M.; Dunn, B.M. and Fanucci, G.E., *Subtype Polymorphisms Among HIV-1 Protease Variants Confer Altered Flap Conformations and Flexibility*, *J. Am. Chem. Soc.*, **131** (41), 14650-1 (2009)
- Kem, W.R.; Rocca, J.; Garraffo, H.M.; Spande, T.F.; Daly, J.W. and Soti, F., *Synthesis and spectroscopic comparison of the eight methyl-2,3'-bipyridyl*, *Heterocycles*, **79**, 1025-1041 (2009)
- Kemper, A.; Cao, C.; Hirschfeld, P.J. and Cheng, H.-P., *Effects of cobalt doping and three-dimensionality in $BaFe_2As_2$* , *Phys. Rev. B*, **80**, 104511 (2009)
- Kemper, A.; Hirschfeld, P.J.; Cheng, H.-P.; Doluweera, G.S.P.; Jarrell, M. and Maier, T.A., *Insensitivity of superconductivity to disorder in the cuprates*, *Phys. Rev. B*, **79**, 104502 (2009)
- Kikugawa, N.; Balicas, L. and Mackenzie, A.P., *Physical Properties of Single-Crystalline $CaRuO_3$ Grown by a Floating-Zone Method*, *J. Phys. Soc. Japan*, **78**, 014701 (2009)
- Kim, J.H.; Astarly, G.W.; Chen, X.M.; Mareci, T.H. and Sarntinoranont, M., *Voxelized Model of Interstitial Transport in the Rat Spinal Cord Following Direct Infusion Into White Matter*, *J. Biomedical Engineering*, **131** (7), 071007 (2009)
- Kim, J.S.; Bedorf, D. and Stewart, G.R., *Effect of disorder induced by heavy-ion irradiation on $CeCoIn_5$* , *J. Low Temp. Phys.*, **157** (1/2), 29-35 (2009)
- Kim, J.S.; Kim, E.G. and Stewart, G.R., *Specific heat anomalies for $T \ll T_c$ in superconducting single crystal doped $BaFe_2As_2$: comparison of different flux growth methods*, *J. Phys.: Condens. Mat.*, **21**, 252201-1 to 3 (2009) [[read online](#)]
- Kim, J.S.; Stewart, G.R. and Samwer, K., *Evolution of Physical Properties with decreasing size in $Ce(Ru_{0.4}Rh_{0.2})_2Si_2$* , *Phys. Rev. B*, **79**, 165119-1 to 8 (2009) [[read online](#)]
- Kim, J.W. (Jae Wook); Haam, S.Y.; Oh, Y.S.; Park, S.; Cheong, S.-W.; Sharma, P.A.; Jaime, M.; Harrison, N.; Han, J.H. (Jung Hoon); Jeon, G.-S. (Gun-Sang); Coleman, P. and Kim, K.H. (Kee Hoon), *Observation of a multiferroic critical end point*, *P. Natl. Acad. Sci. U.S.A.*, **106** (37), 15573 (2009) [[read online](#)]
- Kim, S.; Rodgers, R.P.; Blakney, G.T.; Hendrickson, C.L. and Marshall, A.G., *Automated Electrospray Ionization FT-ICR Mass Spectrometry for Petroleum Analysis*, *J. Mass Spectrometry*, **20**, 263-268 (2009)
- Kim, Y.H.; Kaur, N.; Atkins, B.M.; Dalal, N.S. and Takano, Y., *Fluctuation-Induced Heat Release from Temperature-Quenched Nuclear Spins near a Quantum Critical Point*, *Phys. Rev. Lett.*, **103**, 247201 (2009) [[read online](#)]
- Kirchner, S.; Si, Q. and Ingersent, K., *Finite-size scaling of classical long-ranged Ising chains and the criticality of dissipative quantum impurity models*, *Phys. Rev. Lett.*, **102**, 166405 (2009)
- Kohama, Y.; Kamihara, Y.; Baily, S.A.; Civale, L.; Riggs, S.C.; Balakirev, F.F.; Atake, T.; Jaime, M.; Hirano, M. and Hosono, H., *Doping dependence of the upper critical field and Hall resistivity of $LaFeAsO_{1-x}F_x$ ($x=0, 0.025, 0.05, 0.07, 0.11$, and 0.14)*, *Phys. Rev. B*, **79**, 144527 (2009) [[read online](#)]
- Kohama, Y.; Rachi, T.; Ju, J.; Li, Z.; Tang, J.; Kumashiro, R.; Izumisawa, S.; Kawaji, H.; Atake, T.; Sawa, H.; Murata, Y.; Komatsu, K. and Tanigaki, K., *Rotational sublevels of an ortho-hydrogen molecule encapsulated in an isotropic C60 cage*, *Phys. Rev. Lett.*, **103** (7), 073001 (2009)
- Kramerova, I.; Kudryashova, E.; Wu, B.; Germain, S.; Vandenborne, K.; Romain, N.; Haller, R.; Verity, M.A. and Spencer, M.J., *Mitochondrial abnormalities, energy deficit and oxidative stress are features of calpain 2 deficiency in skeletal muscle*, *Human Molecular Genetics*, **18** (17), 3194-3205 (2009)
- Kremers, G.J.; Hazelwood, K.L.; Murphy, C.S.; Davidson, M.W. and Piston, D.W., *Photoconversion in orange and red fluorescent proteins*, *Nature Methods*, **6** (5), 355-358 (2009) [[read online](#)]
- Kühne, H.; Klaus, H.-H.; Grossjohann, S.; Brenig, W.; Litterst, F.J.; Reyes, A.P.; Kuhns, P.L.; Turnbull, M.M. and Landee, C.P., *Quantum critical dynamics of an $S=1/2$ antiferromagnetic Heisenberg chain studied by ^{13}C NMR spectroscopy*, *Phys. Rev. B*, **80**, 045110 (2009)
- Kwan, J.C.; Eksioğlu, E.A.; Liu, C.; Paul, V.J. and Luesch, H., *Grassystatins A-C from Marine Cyanobacteria, Potent Cathepsin E Inhibitors That Reduce Antigen Presentation*, *J. Med. Chem.*, **52** (18), 5732-5747 (2009)

- Kwan, J.C.; Taori, K.T.; Paul, V.J. and Luesch, H., *Lyngbyastatins 8–10, Elastase Inhibitors with Cyclic Depsipeptide Scaffolds Isolated from the Marine Cyanobacterium Lyngbya semiplena*, **Marine Drugs**, **7**, 528-538 (2009)
- Lampropoulos, C.; Hill, S. and Christou, G., *A Caveat for Single-Molecule Magnetism: Nonlinear Arrhenius Plots*, **Chem. Phys. Chem.**, **10**, 2397-2400 (2009) [[read online](#)]
- Lawrence, J.; Hill, S.; Yang, E.-C. and Hendrickson, D.N., *Magnetic Quantum Tunneling: Key Insights from Multi-Dimensional High-Field EPR*, **Phys. Chem. Chem. Phys.**, **2009** (11), 6743-6749 (2009) [[read online](#)]
- Lee, J.E.; Kellie, J.F.; Tran, J.C.; Tipton, J.D.; Catherman, A.D.; Thomas, H.M.; Ahif, D.R.; Durbin, K.R.; Vellaichamy, A.; Ntai, I.; Marshall, A.G. and Kelleher, N.L., *A Robust Two-Dimensional Separation for Top-Down Tandem Mass Spectrometry of the Low-Mass Proteome*, **J. Am. Soc. Mass Spectr.**, **20** (12), 2183-2191 (2009)
- Lee, S.; Jiang, J.Y.; Weiss, J.D.; Folkman, C.M.; Bark, C.W.; Taratini, C.; Xu, A.; Abraimov, D.; Polyanskii, A.; Nelson, C.T.; Zhang, Y.; Baek, S.H.; Jang, H.W.; Yamamoto, A.; Kametani, F.; Pan, X.Q.; Hellstrom, E.E.; Gurevich, A.; Eom, C.B. and Larbalestier, D.C., *Weak-link behavior of grain boundaries in superconducting Ba(Fe_{1-x}Co_x)₂As₂ bicrystals*, **Appl. Phys. Lett.**, **95**, 212505 (2009)
- Lee, S.J.; Pishko, G.L.; Astary, G.W.; Mareci, T.H. and Sarntinoranont, M., *Characterization of an Anisotropic Hydrogel Tissue Substrate for Infusion Testing*, **J. Applied Polymer Science**, **114** (4), 1992-2002 (2009)
- Li Calzi, S.; Kent, D.L.; Chang, K.-H.; Padgett, K.R.; Afzal, A.; Chandra, S.B.; Caballero, S.; English, D.; Garlington, W.; Hiscott, P.S.; Sheridan, C.M.; Grant, M.B. and Forder, J.R., *Labeling of Stem Cells with Monocrystalline Iron Oxide for Tracking and Localization by Magnetic Resonance Imaging*, **Microvascular Research**, **78** (1 (June)), 132-139 (2009)
- Li, D.S.; Garmestani, H. and Schwartz, J., *Modeling thermal conductivity in UO₂ with BeO additions as a function of microstructure*, **J. Nucl. Mat.**, **392**, 22-27 (2009) [[read online](#)]
- Li, D.W. and Bruschweiler, R., *A Dictionary for Protein Side-Chain Entropies from NMR Order Parameters*, **J. Am. Chem. Soc.**, **131**, 7226-7227 (2009)
- Li, D.W. and Bruschweiler, R., *All-atom contact model for understanding protein dynamics from crystallographic B-factors*, **Biophysical J.**, **96**, 3074-3081 (2009)
- Li, D.W. and Bruschweiler, R., *In silico relationship between configurational entropy and soft degrees of freedom in proteins and peptides*, **Phys. Rev. Lett.**, **102**, 118108 (2009)
- Li, D.W.; Meng, D. and Bruschweiler, R., *Short-Range Coherence of Internal Protein Dynamics Revealed by High-Precision In Silico Study*, **J. Am. Chem. Soc.**, **131**, 14610-14611 (2009)
- Li, J.; Clinite, R.; Wang, X. and Cao, J., *Simulation of ultrafast heating induced structural dynamics using a one-dimensional spring model*, **Phys. Rev. B**, **80**, 014304 (2009)
- Li, W.; Vicente, C.L.; Xia, J.S.; Pan, W.; Tsui, D.C.; Pfeiffer, L.N. and West, K.N., *Publisher's Note: Scaling in Plateau-to-Plateau Transition: A Direct Connection of Quantum Hall Systems with Anderson Localization Model*, **Phys. Rev. Lett.**, **102** (24), 249901-249905 (2009)
- Li, W.; Vicente, C.L.; Xia, J.S.; Pan, W.; Tsui, D.C.; Pfeiffer, L.N. and West, K.W., *Scaling in Plateau-to-Plateau Transition: A Direct Connection of Quantum Hall Systems with the Anderson Localization Model*, **Phys. Rev. Lett.**, **102** (21), 216801-05 (2009)
- Liang, W.; Zhu, P.; Wang, X.; Nie, S.; Zhang, Z.; Clinite, R.; Cao, J.; Sheng, Z. and Zhang, J., *Ultrafast Electron Diffraction with Spatiotemporal Resolution of Atomic Motion*, **Chinese Phys. Lett.**, **26** (2), 020701 (2009)
- Liu, J.; Datta, S.; Bolin, E.; Lawrence, J.; Beedle, C.C.; Yang, E.-C.; Goy, P.; Hendrickson, D.N. and Hill, S., *Anisotropic exchange in a tetranuclear Co(II) complex*, **Polyhedron**, **28**, 1922-1926 (2009) [[read online](#)]
- Liu, X.T. and Schwartz, J., *On the influence of magnetic field processing on the texture, phase assemblage and properties of low aspect ratio Bi₂Sr₂CaCu₂O_x/AgMg wire*, **Science and Technology of Advanced Materials**, **10**, 014605 (2009) [[read online](#)]
- Liu, X.T.; Nachtrab, W.T.; Wong, T. and Schwartz, J., *Effect of resolidification conditions on Bi₂Sr₂CaCu₂O_x/AgMg coil performance*, **IEEE Trans. Appl. Supercond.**, **19** (3), 2232-2236 (2009) [[read online](#)]
- Long, J.R.; Mills, F.D.; Ganesh, O.K.; Antharam, V.C. and Farver, R.S., *Partitioning, dynamics, and orientation of lung surfactant peptide KL₄ in phospholipid bilayers*, **Biochim. Biophys. Acta**, **In Press**, 00 (2009)
- Lu, J.; Han, K.; Goddard, R.E.; Martovetsky, N.N. and Miller, J.R., *The I_c Irreversible Strain of Some ITER High J_c Nb₃Sn Wires*, **IEEE Trans. Appl. Supercond.**, **19** (3), 2637 (2009)
- Lu, J.; Han, K.; Walsh, R.P.; Dixon, I.; Ferrera, A. and Seeber, B., *Characterization of High J_c Nb₃Sn Strands for the Series-Connected Hybrid Magnet*, **IEEE Trans. Appl. Supercond.**, **19** (3), 2615-2618 (2009)
- Lu, J.; Walsh, R.P. and Han, K., *Low temperature physical properties of a high Mn austenitic steel JK2LB*, **Cryogenics**, **49** (3-4), 133-137 (2009) [[read online](#)]
- Ma, M.; Chen, R.; Ge, Y.; He, H.; Marshall, A.G. and Li, L., *Combining Bottom-Up and Top-Down Mass Spectrometric Strategies for de Novo Sequencing of the Crustacean Hyperglycemic Hormone (CHH) from Cancer borealis*, **Anal. Chem.**, **81**, 240-247 (2009)
- Macia, F.; Hernandez, J.M.; Tejada, J.; Datta, S.; Hill, S.; Lampropoulos, C. and Christou, G., *Effects of quantum mechanics on the deflagration threshold in the molecular magnet Mn₁₂-acetate*, **Phys. Rev. B**, **79**, 092403 (2009) [[read online](#)]
- Maier, T.; Graser, S.; Hirschfeld, P.J. and Scalapino, D.J., *Neutron Scattering Resonance and the Fe-pnictide Superconducting Gap*, **Phys. Rev. B**, **79**, 134520 (2009)
- Maier, T.; Graser, S.; Hirschfeld, P.J. and Scalapino, D.J., *Origin of Gap Anisotropy in Spin Fluctuation Models of the Fe-pnictides*, **Phys. Rev. B**, **79**, 224510 (2009)
- Maivorov, B.; Baily, S.A.; Kohama, Y.; Hiramatsu, H.; Civale, L.; Hirano, M. and Hosono, H., *Angular and field properties of the critical current and melting line of Co-doped SrFe₂As₂ epitaxial films*, **Superconductor Science and Technology**, **22**, 125011 (2009) [[read online](#)]

- Maivorov, B.; Baily, S.A.; Zhou, H.; Ugurlu, O.; Kennison, J.A.; Dowden, P.C.; Holesinger, T.G.; Foltyn, S.R. and Civalle, L., *Synergetic combination of different types of defect to optimize pinning landscape using BaZrO₃-doped YBa₂Cu₃O₇*, **Nature Materials**, **8**, 398 - 404 (2009) [[read online](#)]
- Mal, S.S.; Bassil, B.S.; Ibrahim, M.; Nellutla, S.; van Tol, J.; Dalal, N.S.; Fernandez, J.A.; Lopez, X.; Poblet, J.M.; Biboum, R.N.; Kelta, B. and Kortz, U., *Wheel-Shaped Cu₂₀-Tungstophosphate [Cu₂₀X(OH)₂₄(H₂O)₁₂(P₈W₄₈O₁₈₄)]²⁵⁻ Ion (X = Cl, Br, I) and the Role of the Halide Guest*, **Inorg. Chem.**, **48** (24), 11636-11645 (2009) [[read online](#)]
- Mapolelo, M.M.; Stanford, L.A.; Rodgers, R.P.; Yen, A.T.; Debord, J.D.; Asomaning, S. and Marshall, A.G., *Chemical Speciation of Calcium and Sodium Naphthenate Deposits by Electro spray Ionization FT-ICR Mass Spectrometry*, **Energy & Fuels**, **23**, 349-355 (2009)
- Markwick, P.; Showalter, S.A.; Bouvignies, G.; Bruschweiler, R. and Blackledge, M., *Structural dynamics of protein backbone phi angles: extended molecular dynamics simulations versus experimental ³J scalar couplings*, **J. Biomol. NMR**, **45**, 17-21 (2009)
- Martinez-Lillo, J.; Armentano, D.; De Munno, G.; Wernsdorfer, W.; Clemente-Juan, J.; Krzystek, J.; Lloret, F.; Julve, M. and Faus, J., *Heterotetranuclear oxalato-bridged Re^v₃M^{II} (M = Mn, Fe, Co, Ni, Cu) complexes: a new example of single molecule magnet (M = Ni)*, **Inorg. Chem.**, **48** (7), 3027-3038 (2009) [[read online](#)]
- Mathias, J.D.; Ran, Y.; Carter, J.D. and Fanucci, G.E., *Interactions of the GM2 Activator Protein with Phosphatidylcholine Bilayers: A Site-Directed Spin-Labeling Power Saturation Study*, **Biophysical J.**, **97** (5), 1436-1444 (2009)
- Matthew, S.; Paul, V.J. and Luesch, H., *Largamides A.C., tiglic acid-containing cyclodepsipeptides with elastase-inhibitory activity from the marine cyanobacterium Lyngbya confervoides*, **Planta Medica**, **71**, 1625-1629 (2009)
- Matthew, S.; Paul, V.J. and Luesch, H., *Tiglicamides A-C, Cyclodepsipeptides from the Marine Cyanobacterium Lyngbya confervoides*, **Phytochemistry**, **70**, 2058-2063 (2009)
- Matthew, S.; Ross, C.; Paul, V.J. and Luesch, H., *Pompanopeptins A and B, new cyclic peptides from the marine cyanobacterium Lyngbya confervoides*, **Tetrahedron**, **64** (18), 4081-4089 (2009)
- McCamey, D.R.; van Tol, J.; Morley, G.W. and Boehme, C., *Fast Nuclear Spin Hyperpolarization of Phosphorus in Silicon*, **Phys. Rev. Lett.**, **102**, 027601 (2009) [[read online](#)]
- McDonald, R.D.; Harrison, N. and Singleton, J., *Exact mapping of the d_{x²-y²} Cooper-pair wavefunction onto the spin fluctuations in cuprates: the Fermi surface as a driver for 'high T_c' superconductivity*, **J. Phys. -Condens. Mat.**, **21**, 012201 (2009)
- McGraw, T.; Vemuri, B.; Ozarslan, E.; Chen, Y.M. and Mareci, T., *Variational Denoising of Diffusion Weighted MRI*, **Inverse Problems and Imaging**, **3** (4), 625-648 (2009)
- McKenna, A.M.; Purcell, J.M.; Rodgers, R.P. and Marshall, A.G., *Identification of Vanadyl Porphyrins in a Heavy Crude Oil and Raw Asphaltene by Atmospheric Pressure Photoionization FT-ICR Mass Spectrometry*, **Energy & Fuels**, **23**, 2122-2128 (2009)
- McKinney, S.A.; Murphy, C.S.; Hazelwood, K.L.; Davidson, M.W. and Looger, L.L., *A bright and photostable photoconvertible fluorescent protein*, **Nature Methods**, **6** (2), 131-133 (2009) [[read online](#)]
- McNeill, S.A.; Gor'kov, P.L.; Shetty, K.; Brey, W.W. and Long, J.R., *A low-E magic angle spinning probe for biological solid state NMR at 750 MHz*, **J. Magn. Reson.**, **197** (2), 135-144 (2009) [[read online](#)]
- Meickle, T.; Matthews, S.; Ross, C.; Luesch, H. and Paul, V., *Bioassay-Guided Isolation and Identification of Desacetylmicrocolin B from Lyngbya cf. polychroa*, **Planta Medica**, **75**, 1427-1430 (2009)
- Menjoge, A.; Dixon, J.; Brennecke, J.F.; Maginn, E.J. and Vasenkov, S., *Influence of Water on Diffusion in Imidazolium-Based Ionic Liquids: A Pulsed Field Gradient NMR Study*, **J. Phys. Chem. B**, **113**, 6353-6359 (2009)
- Menjoge, A.R. and Vasenkov, S., *Suppression of the Anomalous Relationship between Diffusivities of Cations and Anions by Water in Imidazolium-Based Ionic Liquids*, **Diffusion Fundamentals**, **9**, 3.1-3.7 (2009)
- Menjoge, A.R.; James-Smith, M.A.; Shah, D. and Vasenkov, S., *Influence of breakup and reformation of micelles on surfactant diffusion in pure and mixed micellar systems*, **Microporous and Mesoporous Materials**, **125**, 85-89 (2009)
- Meyer-Baese, A.; Koshkouei, A.J.; Emmett, M.R. and Goodall, D.P., *Global stability analysis and robust design of multi-time-scale biological networks under parametric uncertainties*, **Neural Networks**, **22**, 658-663 (2009)
- Miller, J.; Schwenk, K.; Long, M.; Theriaque, D.; Towler, S.; Liu, Y.; He, G.; Driscoll DJ. and Leonard, C.M., *Early Childhood Obesity is Associated with Compromised Cerebellar Development.*, **Developmental Neuropsychology**, **34** (3), 272-283 (2009)
- Mishra, V.; Boyd, G.; Graser, S.; Maier, T.; Hirschfeld, P.J. and Scalapino, D.J., *Lifting of nodes by disorder in extended-s-state superconductors: Application to ferropnictides*, **Phys. Rev. B**, **79**, 094512 (2009)
- Mishra, V.; Vorontsov, A.; Hirschfeld, P.J. and Vekhter, I., *Theory of thermal conductivity in extended-s state superconductors: application to ferropnictides*, **Phys. Rev. B**, **80**, 224525 (2009)
- Misra, R.; Hebard, A.F.; Muttalib, K.A. and Wolfe, P., *Spin-wave mediated quantum corrections to the conductivity in thin ferromagnetic gadolinium films*, **Phys. Rev. B**, **79**, 140408(R) (2009)
- Misra, S. and Froelich, P.N., *Measurement of lithium isotope ratios by Quadrupole ICP-MS: Application to seawater and natural carbonates*, **J. Analytical Atomic Spectrometry**, **24**, 1524-1533 (2009) [[read online](#)]
- Miyashita, S.; Nishino, M.; Konishi, Y.; Tokoro, H.; Boukheddaden, K.; Varret, F. and Rikvold, P.A., *New type of ordering process with volume change of molecules in the spin-crossover transition, and its new aspects of dynamical processes*, **J. Phys.: Conf. Series**, **148**, 012027 (2009) [[read online](#)]
- Miyashita, S.; Rikvold, P.A.; Mori, T.; Konishi, Y.; Nishino, M. and Tokoro, H., *Threshold phenomena under photoexcitation of spin-crossover materials with cooperativity due to elastic interactions*, **Phys. Rev. B**, **80**, 064414 (2009) [[read online](#)]
- Moomaw, E.W.; Angerhofer, A.; Moussatche, P.; Ozarowski, A.; Garcia-Rubio, I. and Richards, N.G.J., *Metal Dependence of Oxalate Decarboxylase Activity*, **Biochemistry**, **48**, 6116-6125 (2009) [[read online](#)]

- Moon, B.H.; Masuhara, N.; Bhupathi, P.; Gonzalez, M.; Meisel, M.W.; Lee, Y. and Mulders, N., *Ultrasound attenuation measurements in the A-like phase of superfluid ^3He in areogel*, *J. Phys. Conf. Ser.*, **150**, 032061-032065 (2009) [[read online](#)]
- Motowidlo, L.; Lee, P.J. and Larbalestier, D.C., *The effect of second phase additions on the microstructure and bulk pinning force in Nb_3Sn PIT wire*, *IEEE Trans. Appl. Supercond.*, **19** (3), 2568-2572 (2009)
- Mui, S.; Ramaswamy, K.; Stanton, C.J.; Crooker, S.A. and Hayes, S.E., *Manifestation of Landau level effects in optically-pumped NMR of semi-insulating GaAs*, *Phys. Chem. Chem. Phys.*, **11**, 7031 (2009)
- Mukhopadhyay, S.; Oh, S.; Mounce, A.M.; Lee, M.-H.; Halperin, W.P.; Ni, N.; Bud'ko, S.L.; Canfield, P.C.; Reyes, A.P. and Kuhns, P.L., *Magnetic impurities in the pnictide superconductor $\text{Ba}_{1-x}\text{K}_x\text{Fe}_2\text{As}_2$* , *New Journal of Physics*, **11**, 055002 (2009) [[read online](#)]
- Musfeldt, J.L.; Vergara, L.I.; Brinzari, T.V.; Lee, C.; Tung, L.C.; Kang, J.; Wang, Y.J.; Schlueter, J.A.; Manson, J.L.; Sun, C. and Whangbo, M.-H., *Magnetoelastic coupling through the antiferromagnet-to-ferromagnet transition of quasi-two-dimensional $[\text{Cu}(\text{HF}_2)(\text{pyz})_2]\text{BF}_4$ using infrared spectroscopy*, *Phys. Rev. Lett.*, **103**, 157401 (2009)
- Nachtrab, W.T.; Wong, T.; Liu, X.T. and Schwartz, J., *The effect of filament diameter on J_c in high filament count $\text{Bi2212}/\text{Ag}$ round wire*, *IEEE Trans. Appl. Supercond.*, **19** (3), 3061-3066 (2009) [[read online](#)]
- Nanok, T.; Vasenkov, S.; Keil, F.J. and Fritzsche, S., *Molecular dynamics simulation study of the concentration dependence of the self-diffusivity of methanol in Na_x zeolite*, *Microporous and Mesoporous Materials*, **127** (3), 176-181 (2009)
- Nath, S.; Kaitanis C.; Ramachandran, V.; Dalal, N.S. and Perez, J.M., *Synthesis, Magnetic Characterization, and Sensing Applications of Novel Dextran-Coated Iron Oxide Nanorods*, *Chem. Mater.*, **21** (8), 1761-1767 (2009)
- Nguyen, D.N.; Sastry, P.V.P.S.S.; Knoll, D.C. and Schwartz, J., *Temperature dependence of total AC loss in high temperature superconducting tapes*, *IEEE Trans. Appl. Supercond.*, **19** (4), 3637-3644 (2009) [[read online](#)]
- Nie, S.; Wang, X.; Li, J.; Clinite, R. and Cao, J., *Comment on "Nanoscale heat transfer in a thin aluminum film and femtosecond time-resolved electron diffraction"*, *Appl. Phys. Lett.*, **94**, 166101 (2009)
- Nie, S.; Wang, X.; Li, J.; Clinite, R. and Cao, J., *Femtosecond Electron Diffraction: Direct Probe of Ultrafast Structural Dynamics in Metal Films*, *Microscopy Research and Technique*, **72** (3), 131 (2009)
- Nieto, I.; Bontchev, R.P.; Ozarowski, A.; Smirnov, D.; Krzystek, J.; Telsler, J. and Smith, J.M., *Synthesis and spectroscopic investigations of four-coordinate nickel complexes supported by a strongly donating scorpionate ligand*, *Inorg. Chim. Acta*, **362**, 4449-4460 (2009) [[read online](#)]
- O'Farrell, E.C.T.; Tompsett, D.A.; Sebastian, S.E.; Harrison, N.; Capan, C.; Balicas, L.; Kuga, K.; Matsuo, A.; Kindo, K.; Tokunaga, M.; Nakatsuji, S.; Csányi, G.; Fisk, Z. and Sutherland, M.L., *Role of f Electrons in the Fermi Surface of the Heavy Fermion Superconductor $\beta\text{-YbAlB}_4$* , *Phys. Rev. Lett.*, **102**, 216402 (2009)
- Orendáčová, A.; Čížmár, E.; Sedláková, L.; Hanko, J.; Kajňáková, M.; Orendáč, M.; Feher, A.; Xia, J.S.; Yin, L.; Pajerowski, D.M.; Meisel, M.W.; Zeleňák, V.; Zvyagin, S. and Wosnitza, J., *Interplay of frustration and magnetic field in the two-dimensional quantum antiferromagnet $\text{Cu}(\text{tn})\text{Cl}_2$* , *Phys. Rev. B*, **80**, 144418 (2009) [[read online](#)]
- Ozarowski, A.; Szymanska, I.B.; Muziol, T. and Jezierska, J., *High-Field EPR and Magnetic Susceptibility Studies on Binuclear and Tetranuclear Copper Trifluoroacetate Complexes. X-ray Structure Determination of Three Tetranuclear Quinoline Adducts of Copper(II) Trifluoroacetate*, *J. Am. Chem. Soc.*, **131**, 10279-10292 (2009) [[read online](#)]
- Padmanabhan, M.; Gokmen, T. and Shayegan, M., *Density dependence of valley polarization energy for composite fermions*, *Phys. Rev. B*, **80**, 035423 (2009) [[read online](#)]
- Paduan, A.; Al-Hassanieh, K.A.; Sengupta, P. and Jaime, M., *Critical properties at the field-induced Bose-Einstein condensation in $\text{NiCl}_2\text{-SC}(\text{NH}_2)_2$* , *Phys. Rev. Lett.*, **102**, 077204 (2009)
- Paduan, A.; Al-Hassanieh, K.A.; Sengupta, P.; Zapf, V.S.; Jaime, M.; Lacerda, A.H. and Kenzelmann, M., *Critical behavior of the magnetization in the spin-gapped system $\text{NiCl}_2\text{-SC}(\text{NH}_2)_2$* , *J. Appl. Phys.*, **105**, 07D501 (2009)
- Page, R.C.; Lee, S.; Moore, J.D.; Opella, S.J. and Cross, T.A., *Backbone Structure of a small Helical Integral Membrane Protein: A unique structural characterization*, *Protein Science*, **18** (1), 134-146 (2009)
- Painter, T.A.; Bird, M.D.; Dixon, I.R.; Ehmler, H.; Heinrich, J.; Smeibidl, P.; Xu, T. (Ting) and Zhai, Y. (Yuhu), *Series-Connected Hybrid Magnetic Shielding Conceptual Design for the Helmholtz Centre Berlin for Materials and Energy*, *IEEE Trans. Appl. Supercond.*, **19** (3), 1600-1603 (2009)
- Pajerowski, D. and Meisel, M.W., *Magnetometer probe with low temperature rotation and optical fibers*, *J. Phys. -Condens. Mat.*, **150**, 012034-012039 (2009)
- Pajerowski, D.M.; Gardner, J.E.; Talham, D.R. and Meisel, M.W., *Tuning the Sign of Photoinduced Changes in Magnetization: Spin Transitions in the Ternary Metal Prussian Blue Analogue $\text{Na}_a\text{Ni}_{1-x}\text{Co}_x[\text{Fe}(\text{CN})_6]_b \cdot n\text{H}_2\text{O}$* , *J. Am. Chem. Soc.*, **131** (36), 12927-12936 (2009)
- Pantea, C.; Stroe, I.; Ledbetter, H.; Betts, J.B.; Zhao, Y.; Daemen, L.L.; Cynn, H. and Miglioni, A., *Bulk modulus of osmium, 4-300 K*, *Acta Mater.*, **57** (2), 544-548 (2009)
- Pantea, C.; Stroe, I.; Ledbetter, H.; Betts, J.B.; Zhao, Y.; Daemen, L.L.; Cynn, H. and Miglioni, A., *Elastic constants of osmium between 5 and 300K*, *Phys. Rev. B*, **80** (2), 024112 (2009)
- Park, J.G.; Smithyman, J.; Lin, C.Y.; Cooke, A.; Kismarahardja, A.W.; Li, S.; Liang, R.; Brooks, J.S.; Zhang, C. and Wang, B., *Effects of surfactants and alignment on the physical properties of single walled carbon nanotube buckypaper*, *J. Appl. Phys.*, **106** (104310), 1-6 (2009) [[read online](#)]
- Parks, C.; Sullivan, N.S. and Stachowiak, P., *Measurements of the Nuclear Spin-Spin Relaxation Times for Commensurate 3He -Ne Films Adsorbed on Hexagonal Boron Nitride*, *J. Phys.: Conf. Series*, **150**, 032103-032107 (2009)
- Patel, U.; Xiao, Z.L.; Gurevich, A.; Avci, S.; Hua, J.; Divan, R.; Welp, U. and Kwok, W.K., *Magneto-resistance oscillations in superconducting granular niobium nitride nanowires*, *Phys. Rev. B*, **80**, 012504 (2009)
- Peng, L.; Cai, S.H.; Fu, R.; Ye, C. and Chen, Z., *Harmonic Peaks in 1D NMR Spectra Induced by Radiation Damping Fields*, *Chem. Phys. Lett.*, **479**, 165-170 (2009)

- Pilla, S.; Hamida, J.A.; Muttalib, K.A. and Sullivan, N.S., *Generalized Fluctuation Dissipation and Thermal Hysteresis of Dielectric Susceptibility in Frustrated Molecular Orientational Glasses*, **J. Phys. -Condens. Mat.**, **150**, 042192-042196 (2009)
- Piston, D.W.; Kremers, G.J.; Benninger, R.K. and Davidson, M.W., *Photoactivation in Fluorescence Microscopy*, **Microscopy Today**, **17** (4), 8-13 (2009) [[read online](#)]
- Polyanskii, A.A.; Lee, P.J.; Jewell, M.C.; Barzi, E.; Turrioni, D.; Zlobin, A.V. and Larbalestier, D.C., *Evidence for highly localized damage in internal tin and powder-in-tube Nb₃Sn strands rolled before reaction obtained from coupled magneto-optical imaging and confocal laser scanning microscopy*, **Superconductor Science and Technology**, **22** (9), 095008 (13pp) (2009) [[read online](#)]
- Purcell, K.M.; Graf, D.; Kano, M.; Bourg, J.; Palm, E.C.; Murphy, T.; McDonald, R.; Mielke, C.H.; Altarawneh, M.M.; Petrovic, C.; Hu, R.; Ebihara, T.; Cooley, J.; Schlottmann, P. and Tozer, S.W., *Pressure evolution of a field-induced Fermi surface reconstruction and of the Néel critical field in CeIn₃*, **Phys. Rev. B**, **79**, 214428 (2009)
- Qian, C. and Brey, W.W., *Impedance matching with an adjustable segmented transmission line*, **J. Magn. Reson.**, **199**, 104-110 (2009)
- Qian, C.; Fu, R.; Gor'kov, P.L.; Brey, W.W.; Cross, T.A. and Gan, Z., *¹⁴N Polarization Inversion Spin Exchange at Magic Angle (PISEMA)*, **J. Magn. Reson.**, **196**, 96-99 (2009)
- Redler, G.; Lampropoulos, C.; Datta, S.; Koo, C.; Stamatatos, T.C.; Chakov, N.E.; Christou, G. and Hill, S., *Crystal lattice desolvation effects on the magnetic quantum tunneling of single-molecule magnets*, **Phys. Rev. B**, **80**, 094408 (2009) [[read online](#)]
- Riggs, S.; Tarantini, C.; Jaroszynski, J.; Gurevich, A.; Palenzona, A.; Putti, M.; Duc Nguyen, T. and Affronte, M., *Specific heat investigation in high magnetic field of the magnetic ordering of the rare-earth lattice in RFeAsO: The case of Sm*, **Phys. Rev. B**, **80**, 214404 (2009) [[read online](#)]
- Riggs, S.C.; Kemper, J.B.; Jo, Y.; Stegen, Z.; Balicas, L.; Boebinger, G.S.; Balakirev, F.F.; Migliori, A.; Chen, H.; Liu, R.H. and Chen, X.H., *Magnetic-field-induced log-T insulating behavior in the resistivity of fluorine-doped SmFeAsO_{1-x}F_x*, **Phys. Rev. B**, **79**, 212510 (2009)
- Riggs, S.C.; McDonald, R.D.; Kemper, J.B.; Stegen, Z.; Boebinger, G.S.; Balakirev, F.F.; Kohama, Y.; Migliori, A.; Chen, H.; Liu, R.H. and Chen X.H., *Doping dependent nonlinear Hall effect in SmFeAsO_{1-x}F_x*, **J. Phys. -Condens. Mat.**, **21** (41), 412201 (2009)
- Righter, K.; Humayun, M.; Campbell, A.J.; Danielson, L.R.; Hill, D.H. and Drake, M.J., *Experimental studies of metal-silicate partitioning of Sb: Implications for the terrestrial and lunar mantles*, **Geochim. Cosmochim. Acta**, **73**, 1487-1504 (2009) [[read online](#)]
- Rikvold, P.A., *Complex Behavior in Simple Models of Biological Coevolution*, **Int. J. Mod. Phys. C**, **20**, 1387-1397 (2009) [[read online](#)]
- Rikvold, P.A., *Complex Dynamics in Models of Biological Coevolution with Ratio-dependent Functional Response*, **Ecological Complexity**, **6**, 443-452 (2009) [[read online](#)]
- Riss, O.; Gerber, A.; Korenblit, I.Ya.; Suslov, A.; Passacantando, M., and Ottaviano, L., *Magnetization-driven metal-insulator transition in strongly disordered Ge:Mn magnetic semiconductors*, **Phys. Rev. B Rapid Commun.**, **79**, 241202(R) (2009)
- Rizzo, M.A.; Davidson, M.W. and Piston, D.W., *Fluorescent Protein Tracking and Detection: Applications Using Fluorescent Proteins in Living Cells*, **Cold Spring Harbor Protocols**, **2009**, doi:10.1101/pdb.top64 (2009) [[read online](#)]
- Rizzo, M.A.; Davidson, M.W. and Piston, D.W., *Fluorescent Protein Tracking and Detection: Fluorescent Protein Structure and Color Variants*, **Cold Spring Harbor Protocols**, **2009**, doi:10.1101/pdb.top63 (2009) [[read online](#)]
- Rodrigues, D. Jr.; Jiang, J.; Zhu, Y.; Voyles, P.; Larbalestier, D.C. and Hellstrom, E.E., *Flux pinning optimization of MgB₂ bulk samples prepared using high-energy ball milling and addition of TaB₂*, **IEEE Trans. Appl. Supercond.**, **19** (3), 2797 (2009) [[read online](#)]
- Sachs, M.; Rakhmilevitch, D.; Ben Shalom, M.; Shefler, S.; Palevski, A. and Dagan Y., *Anomalous magneto-transport at the superconducting interface between LaAlO₃ and SrTiO₃*, **Physica C**, **xxx**, xxx (2009) [[read online](#)]
- Salmon, L.; Bouvignies, G.; Markwick, P.; Lakomek, N.; Showalter, S.; Li, D.W.; Walter, K.; Griesinger, C.; Bruscheiler, R. and Blackledge, M., *Protein conformational flexibility from structure-free analysis of NMR dipolar couplings: quantitative and absolute determination of backbone motion in ubiquitin*, **Angew. Chem. Int. Ed.**, **48**, 4154-4157 (2009)
- Samulon, E.C.; Kohama, Y.; McDonald, R.D.; Shapiro, M.C.; Al-Hassanieh, K.A.; Batista, C.D.; Jaime, M. and Fisher, I.R., *Asymmetric Quintuplet Condensation in the Frustrated S=1 Spin Dimer Compound Ba₂Mn₂O₈*, **Phys. Rev. Lett.**, **103**, 047202 (2009) [[read online](#)]
- Sanders, M.; Mueller, R.; Menjoge, A. and Vasenkov, S., *Pulsed Field Gradient Nuclear Magnetic Resonance Study of Time-Dependent Diffusion Behavior and Exchange of Lipids in Planar-Supported Lipid Bilayers*, **J. Phys. Chem. B**, **113**, 14355-14364 (2009)
- Savici, A.T.; Granroth, G.E.; Broholm, C.L.; Pajerowski, D.M.; Brown, C.M.; Talham, D.R.; Meisel, M.W.; Schmidt, K.P.; Uhrig, G.S. and Nagler, S.E., *Neutron scattering evidence for isolated spin-(1/2) ladders in (C₅D₁₂N)₂CuBr₄*, **Phys. Rev. B**, **80**, 094411 (2009)
- Schäfer, M.; Drayns, M.K.; Blunk, D.; Purcell, J.M.; Hendrickson, C.L.; Marshall, A.G.; Mookherjee, A. and Armentrout, P.B., *Kinetic Determination of Potassium Affinities by IRMPD: Elucidation of Precursor Ion Structures*, **J. Phys. Chem. A**, **113**, 7779-7783 (2009)
- Schlegel, J.; Armstrong, G.S.; Redzic, J.S.; Zhang, F. and Eisenmesser, E.Z., *Characterizing and controlling the inherent dynamics of cyclophilin-A*, **Protein Science**, **18** (4), 811-824 (2009)
- Schlegel, J.; Redzic, J.S.; Porter, C.C.; Yurchenko, V.; Bukrinsky, M.; Labeikovskiy, W.; Armstrong, G.S.; Zhang, F.; Isern, N.G.; DeGregori, J.; Hodges, R. and Eisenmesser, E.Z., *Solution Characterization of the Extracellular Region of CD147 and Its Interaction with Its Enzyme Ligand Cyclophilin A*, **J. Mol. Biol.**, **391** (3), 518-535 (2009)
- Schmiedeshoff, G.M.; Lounsbury, A.W.; Tozer, S.W.; Palm, E.C.; Hannahs, S.T.; Murphy, T.P.; Park, J.H.; Opeil, C.P. and Bedell, K.S., *Thermal expansion and magnetostriction of a nearly saturated ³He-⁴He mixture*, **Philosophical Magazine**, **89** (22-24), 2071-2078 (2009)
- Sebastian, S.E.; Harrison, N.; Batista, C.D.; Trugman, S.A.; Fanelli, V.; Jaime, M.; Murphy, T.P.; Palm, E.C.; Harima, H. and Ebihara, T., *Heavy holes as a precursor to superconductivity in antiferromagnetic CeIn₃*, **P. Natl. Acad. Sci. U.S.A.**, **106**, 7741 (2009)
- Sebastian, S.E.; Harrison, N.; Mielke, C.H.; Liang, R.X.; Bonn, D.A.; Hardy, W.N. and Lonzarich, G.G., *Spin-Order Driven Fermi Surface Reconstruction Revealed by Quantum Oscillations in an Underdoped High T_c Superconductor*, **Phys. Rev. Lett.**, **103**, 256405 (2009) [[read online](#)]

- Seidel, A. and Yang, K., *Momentum-resolved tunneling into the Pfaffian and anti-Pfaffian edges*, **Phys. Rev. B Rapid Commun.**, **80**, 241309 (2009) [[read online](#)]
- Sen, G.; Bizimis, M.; Das, R.; Paul, D.K.; Ray, A. and Biswas, S., *Deccan plume, lithosphere rifting, and volcanism in Kutch, India*, **Earth Planet. Sci. Lett.**, **277**, 101-111 (2009)
- Serrano, G.; Serquis, A.; Civale, L.; Maiorov, B.; Holesinger, T.G.; Balakirev, F. and Jaime, M., *Single-wall carbon nanotubes addition effects on the superconducting properties of MgB₂*, **Int. J. Mod. Phys. B**, **23**, 3465 (2009)
- Shabani, J.; Gokmen, T.; Chiu, Y.T. and Shayegan, M., *Evidence for Developing Fractional Quantum Hall States at Even Denominator 1/2 and 1/4 Fillings in Asymmetric Wide Quantum Wells*, **Phys. Rev. Lett.**, **103**, 256802 (2009) [[read online](#)]
- Shabani, J.; Gokmen, T. and Shayegan, M., *Correlated States of Electrons in Wide Quantum Wells at Low Fillings: The Role of Charge Distribution Symmetry*, **Phys. Rev. Lett.**, **103**, 046805 (2009) [[read online](#)]
- Shaner, N.C.; Lin, M.Z.; McKeown, M.R.; Steinbach, P.A.; Hazelwood, K.L.; Davidson, M.W. and Tsien, R.Y., *Evaluating and improving the photostability of fluorescent proteins*, **Proc. SPIE**, **7191**, 719105-11 (2009) [[read online](#)]
- Sharma, R., *Microimaging of hairless rat skin by magnetic resonance at 900 MHz*, **Magnet. Reson. Imaging**, **27**, 240-255 (2009) [[read online](#)]
- Sharp, K.; Arthur, K.E.; Gu, L.; Ross, C.; Harrison G.; Gunasekera, S.P.; Meicle, T.; Matthew, S.; Luesch, H.; Thaker, R.W.; Sherman, D.H. and Paul, V.J., *Phylogenetic and chemical diversity of three chemotypes of bloom-forming Lyngbya (Cyanobacteria: Oscillatoriales) from reefs of Southeast Florida*, **Appl. Environ. Microbiol.**, **75**, 528-533 (2009)
- Shaver, J.; Parra-Vasquez, A.N.G.; Hansel, S.; Portugall, O.; Mielke, C.H.; von Ortenberg, M.; Hauge, R.H.; Pasquali, M. and Kono, J., *Alignment Dynamics of Single-Walled Carbon Nanotubes in Pulsed Ultrahigh Magnetic Fields*, **ACS NANO**, **31**, 131-138 (2009) [[read online](#)]
- Shaver, J.A.; Srivastava, A.; Kono, J.; Crooker, S.A.; Htoon, H.; Klimov, V.I.; Fagan, J.A.; Hobbie, E.K.; Ubrig, N.; Portugall, O.; Perebeinos, V. and Avouris, P.H., *High field magneto-optical spectroscopy of highly aligned individual and ensemble single-walled carbon nanotubes*, **Int. J. Mod. Phys. B**, **23**, 2667 (2009) [[read online](#)]
- Shcherbo, D.; Murphy, C.S.; Ermakova, G.V.; Solovieva, E.A.; Chepurnykh, T.V.; Shcheglov, A.S.; Verkhusha, V.V.; Pletnev, V.Z.; Hazelwood, K.L.; Roche, P.M.; Lukyanov, S.; Zaraisky, A.G.; Davidson, M.W. and Chudakov, D.M., *Far-red fluorescent tags for protein imaging in living tissues*, **Biochemical J.**, **418**, 567-574 (2009) [[read online](#)]
- Shen, T.; Gu, J.J.; Xu, M.; Wu, Y.Q.; Bolen, M.L.; Capano, M.A.; Engel, L.W. and Ye, P.D., *Observation of quantum-Hall effect in gated epitaxial graphene grown on SiC (0001)*, **Appl. Phys. Lett.**, **95** (17), 172105 (2009)
- Shen, T.M.; Jiang, J.Y.; Yamamoto, A.; Trociewitz, U.P.; Schwartz, J.; Hellstrom E.E. and Larbalestier, D.C., *Development of high critical current density in untextured round-wire, multifilamentary Bi₂Sr₂CaCu₂O_x round-wire by strong overdoping*, **Appl. Phys. Lett.**, **95**, 152516 (2009)
- Shepherd, T.M.; Thelwall, P.E.; Stanisz, G.J. and Blackband, S.J., *Aldehyde Fixative Solutions Alter the Water Relaxation and Diffusion Properties of Nervous Tissue*, **Magnet. Reson. Med.**, **62** (1), 26-34 (2009)
- Sheppard, D.; Li, D.W.; Bruschiweiler, R. and Tugarinov, V., *Deuterium Spin Probes of Backbone Order in Proteins: H-2 NMR Relaxation Study of Deuterated Carbon alpha-Sites*, **J. Am. Chem. Soc.**, **131**, 15853-15865 (2009)
- Shtengel, G.; Galbraith, J.A.; Galbraith, C.G.; Lippincott-Schwartz, J.; Gillette, J.M.; Manley, S.; Sougrat, R.; Waterman, C.M.; Kanchanawong, P.; Davidson, M.W.; Fetter, R.D. and Hess, H.F., *Interferometric fluorescent super-resolution microscopy resolves 3D cellular ultrastructure*, **P. Natl. Acad. Sci. U.S.A.**, **106** (9), 3125-3130 (2009) [[read online](#)]
- Singh-Bhalla, G.; Selcuk, S.; Dhakal, T.; Biswas, A. and Hebard, A.F., *Intrinsic Tunneling in Phase Separated Manganites*, **Phys. Rev. Lett.**, **102**, 077205 (2009)
- Singleton, J.; McDonald, R.D. and Cox, S., *Recent high-magnetic-field experiments on the "High T_c" cuprates; Fermi-surface instabilities as a driver for superconductivity*, **Physica B**, **404** (3-4), 350-353 (2009)
- Smith, D.F.; Rodgers, R.P.; Rahimi, P.; Teclerariam, A. and Marshall, A.G., *Effect of Thermal Treatment on Acidic Organic Species from Athabasca Bitumen Heavy Vacuum Gas Oil, Analyzed by Negative-Ion Electrospray FT-ICR Mass Spectrometry*, **Energy & Fuels**, **23**, 214-319 (2009)
- Snyder, A. and Bruschiweiler, R., *Generalized indirect covariance NMR formalism for establishment of multidimensional spin correlations*, **J. Phys. Chem. A**, **113**, 12898-12903 (2009)
- Song, H. and Schwartz, J., *Stability and quench behavior of YBa₂Cu₃O_{7-x} coated conductor at 4.2 K, self-field*, **IEEE Trans. Appl. Supercond.**, **19** (5), 3735-3743 (2009) [[read online](#)]
- Song, H. Davidson, M.W. and Schwartz, J., *Dynamic magneto-optical imaging of transport current redistribution and normal zone propagation in YBa₂Cu₃O_x coated conductor*, **Superconductor Science and Technology**, **22**, 062001 (2009) [[read online](#)]
- Soraya, S.; Betancourt, S.S.; Ventura, G.T.; Pomerantz, A.E.; Vilorio, O.; Dubost, F.X.; Zuo, J.; Monson, G.; Bustamante, D.; Purcell, J.M.; Nelson, R.K.; Rodgers, R.P.; Reddy, C.M.; Marshall, A.G. and Mullins, O.C., *Nanoaggregates of Asphaltenes in a Reservoir Crude Oil and Reservoir Connectivity*, **Energy & Fuels**, **23**, 1178-1188 (2009)
- Stoll, S.; Gunn, A.; Brynda, M.; Sughrue, W.; Kohler, A.C.; Ozarowski, A.; Fisher, A.J.; Lagarias, J.C. and Britt, R.D., *Structure of the Biliverdin Radical Intermediate in Phycocyanobilin:Ferredoxin Oxidoreductase Identified by High-Field EPR and DFT*, **J. Am. Chem. Soc.**, **131**, 1986-1995 (2009) [[read online](#)]
- Stroe, I.; Betts, J.B.; Pantea, C.; Trugman, A.; Mitchell, J.N.; Ramos, M.; Friebert, F.; Mielke, C.H. and Migliori, A., *Temperature dependence of elastic moduli for polycrystalline Pu: Comparison of alpha and gamma phases*, **J. Acoust. Soc. Am.**, **125**, 2654 (2009)
- Sun, Y.; Booker, C.F.; Kumari, S.; Day, R.N.; Davidson, M.W. and Periasamy, A., *Characterization of an orange acceptor fluorescent protein for sensitized spectral fluorescence resonance energy transfer microscopy using a white-light laser*, **J. Biomed. Optics**, **14** (5), 054009-11 (2009) [[read online](#)]
- Suslov, A.V., *Resonances of piezoelectric plate with embedded 2D electron system*, **J. Phys.: Conf. Series**, **150**, 022079 (2009)

- Takahashi, S.; van Tol, J.; Beedle C.C.; Hendrickson, D.N.; Brunel, L.C. and Sherwin, M.S., *Coherent manipulation and decoherence of $S=10$ single-molecule magnets*, **Phys. Rev. Lett.**, **102** (08), 087603 (2009) [[read online](#)]
- Taori, K.; Liu, Y.; Paul, V.J. and Luesch, H., *Combinatorial Strategies by Marine Cyanobacteria: Symplostatin 4 an Antimitotic Natural Dolastatin 10/15 Hybrid that Synergizes with the Coproduced HDAC Inhibitor Largazole*, **Chem. Bio. Chem.**, **10**, 1634-1639 (2009)
- Telser, J.; Wu, C.-C.; Chen, K.-Y.; Hsu, H.-F.; Smirnov, D.; Ozarowski, A. and Krzystek, J., *Aminocarboxylate complexes of vanadium(III): electronic structure investigation by high-frequency and -field Electron Paramagnetic Resonance spectroscopy*, **J. Inorg. Biochem.**, **103**, 487-495 (2009) [[read online](#)]
- Thielemann, B.; Rüegg, Ch.; Kiefer, K.; Rønnow, M.H.; Normand, B.; Bouillot, P.; Kollath, C.; Orignac, E.; Citro, R.; Giamarchi, T.; Läuchli, M.A.; Biner, D.; Krämer, W.K.; Wolff-Fabris, F.; Zapf, V.; Jaime, M.; Stahn, J.; Christensen, B.N.; Grenier, B.; McMorrow, F.D. and Mesot, J., *Field-controlled magnetic order in the quantum spin-ladder system $(\text{Hpip})_2\text{CuBr}_4$* , **Phys. Rev. B Rapid Commun.**, **79**, 020408 (2009)
- Thieme, C.L.H.; Gagnon, K.J.; Coulter, J.Y.; Song, H. and Schwartz, J., *Stability of second generation HTS pancake coils at 4.2 K for high heat flux applications*, **IEEE Trans. Appl. Supercond.**, **19** (3), 1626-1632 (2009) [[read online](#)]
- Thompson, K.J.; Liu, S-C; Labbe, G. and Ihas, G.G., *Use of calorimetry to study the energy decay of quantum turbulence*, **J. Phys.: Conf. Series**, **150**, 032111-032115 (2009)
- Thompson, S.H.; Brown, G.; Kuhnle, A.D.; Rikvold, P.A. and Novotny, M.A., *Resolution-dependent mechanisms for bimodal switching-time distributions in simulated Fe nanopillars*, **Phys. Rev. B**, **79**, 024429 (2009) [[read online](#)]
- Tipton, J.D.; Carter, J.D.; Mathias, J.D.; Emmett, M.R.; Fanucci, G.E. and Marshall, A.G., *Sequential Proteolysis and High-Field FTICR MS To Determine Disulfide Connectivity and 4-Maleimide TEMPO Spin-Label Location in L126C GM2 Activator Protein*, **Anal. Chem.**, **81** (18), 7611-7617 (2009) [[read online](#)]
- Torikachvili, M.S.; Bud'ko, S.L.; Ni, N.; Canfield, P.C. and Hannahs, S.T., *Effect of pressure on transport and magnetotransport properties in CaFe_2As_2 single crystals*, **Phys. Rev. B**, **80** (1), 014521 (2009)
- Tsujii, H.; Kim, Y.H.; Yoshida, Y.; Takano, Y.; Murphy, T.P.; Kanada, K.; Saito, S.; Oosawa, A. and Goto, T., *Magnetic Phase Diagram of the Spin-1/2 Antiferromagnetic Ladder $(\text{CH}_3)_2\text{CHNH}_3\text{CuCl}_2$* , **J. Phys.: Conf. Series**, **150**, 042217 (2009) [[read online](#)]
- Tung, L.-C.; Yang, C.L.; Smirnov, D.; Pfeiffer, L.N.; West, K.W.; Du, R.R. and Wang, Y.-J., *Submillimeter wave induced resistance oscillation in ultra high-mobility two dimensional electron system*, **Solid State Commun.**, **149**, 1531 (2009)
- van Tol, J.; Dinse, K.P.; Kungl, H. and Hoffmann, M.J., *Pulsed High-Frequency EPR Investigation of Gadolinium-Doped PbZrO_3 and PbTiO_3* , **Appl. Magn. Reson.**, **36** (2-4), 297-307 (2009) [[read online](#)]
- van Tol, J.; Morley, G.W.; Takahashi, S.; McCamey, D.R.; Boehme, C. and Zvanut, W.E., *High-Field Phenomena of Qubits*, **Appl. Magn. Reson.**, **36** (2-4), 259-268 (2009) [[read online](#)]
- Venkataraman, K. and Hellstrom, E., *Development of a metal-organic decomposition process for growth of Lanthanum manganate buffer layers for coated conductors*, **J. Mater. Res.**, **24**, 1567-1575 (2009)
- Vergara, L.I.; Cao, J.; Tung, L.-C.; Rogado, N.; Yen, F.; Cava, R.J.; Lorenz, B.; Wang, Y.-J. and Musfeldt, J.L., *Magneto-infrared effects in magnetically frustrated $\text{Co}_3\text{V}_2\text{O}_8$* , **Phys. Rev. B**, **xxx**, xx (2009)
- Wade, A.; Fedorov, G.; Smirnov, D.; Kumar, S.; Williams, B.S.; Hu, Q. and Reno, J.L., *Magnetic-field-assisted terahertz quantum cascade laser operating up to 225 K*, **Nature Photonics**, **3**, 41-45 (2009)
- Walter, K.M.; Chanton, J.; Schuur, E.A.G.; Zimov, S.A. and Chapin III, F.S., *Methane production and bubble emissions from arctic lakes: Isotopic implications for source pathways and ages*, **J. Geophysical Research**, **113**, G00A08 (2009) [[read online](#)]
- Wang, B.; Dossey, A.T.; Walse, S.S.; Edison, A.S. and Merz, K.M. Jr., *Relative Configuration of Natural Products by NMR Chemical Shifts*, **J. Natural Products**, **72**, 709-13 (2009)
- Wang, X.; Nie, S.; Park, H.; Li, J.; Clinite, R.; Li, R.; Wang, X. and Cao, J., *Measurement of femtosecond electron pulse length and the temporal broadening due to space charge*, **Rev. Sci. Instrum.**, **80** (1), 013902 (2009)
- Wang, X.R.; Trociewitz, U.P. and Schwartz, J., *Self-field quench behavior of YBCO coated conductors with different stabilizers*, **Superconductor Science and Technology**, **22**, 085005 (2009) [[read online](#)]
- Wilson, R.M.; Chanton, J.; Lewis, G. and Nowacek, D., *Combining Organic Matter Source and Relative Trophic Position Determinations to Explore Trophic Structure in an Estuarine System*, **Estuaries and Coasts**, **32** (5), 999-1010 (2009) [[read online](#)]
- Wilson, R.M.; Chanton, J.; Lewis, G. and Nowacek, D., *Isotopic variation ($\delta^{15}\text{N}$, $\delta^{13}\text{C}$, and $\delta^{34}\text{S}$) with body size in post-larval estuarine consumers*, **Estuarine and Coastal Shelf Science**, **83**, 307-312 (2009)
- Witwicki, M.; Jerzykiewicz, M.; Jaszewski, A. R.; Jezierska, J. and Ozarowski, A., *Influence of Pb(II) Ions on the EPR Properties of the Semiquinone Radicals of Humic Acids and Model Compounds: High Field EPR and Relativistic DFT Studies*, **J. Phys. Chem. A**, **113**, 14115-14122 (2009) [[read online](#)]
- Witwicki, M.; Jezierska, J. and Ozarowski, A., *Solvent effect on EPR, molecular and electronic properties of semiquinone radical derived from 3,4-dihydroxybenzoic acid as model for humic acid transient radicals: High-field EPR and DFT studies*, **Chem. Phys. Lett.**, **473**, 160-166 (2009) [[read online](#)]
- Wolff-Fabris, F.; Francoual, S.; Zapf, V.; Jaime, M.; Scott, B.; Tozer, S.; Hannahs, S.; Murphy, T. and Lacerda, A.H., *Magnetostriction and thermal expansion on 1D quantum spin system azurite*, **J. Phys.: Conf. Series**, **150**, 042030 (2009)
- Xavier, F.R.; Neves, A.; Casellato, A.; Peralta, R.A.; Bortoluzzi, A.J.; Szpoganicz, B.; Severino, P.C.; Terenzi, H.; Tomkowicz, Z.; Ostrovski, S.; Haase, W.; Ozarowski, A.; Krzystek, J.; Telsler, J.; Schenk, G. and Gahan, L.R., *Unsymmetrical $\text{Fe}^{\text{III}}\text{Co}^{\text{II}}$ and $\text{Ga}^{\text{III}}\text{Co}^{\text{II}}$ Complexes as Chemical Hydroxylases: Biomimetic Models for Purple Acid Phosphatases (PAPs)*, **Inorg. Chem.**, **48**, 7905-7921 (2009) [[read online](#)]
- Xia, J.S.; Yin, L.; Adams, E.D. and Sullivan, N.S., *A Compact Capacitive Pressure Transducer*, **J. Phys. -Condens. Mat.**, **150**, 012054-012059 (2009)
- Xu, X.S.; Brinzari, T.V.; Lee, S.; Chu, Y.H.; Martin, L.W.; Kumar, A.; McGill, S.; Rai, R.C.; Ramesh, R.; Gopalan, V.; Cheong, S. and Musfeldt, J.L., *Optical properties and magnetochromism in multiferroic BiFeO_3* , **Phys. Rev. B**, **79**, 134425 (2009)

- Yamamoto, A.; Jaroszynski, J.; Tarantini, C.; Balicas, L.; Jiang, J.; Gurevich, A.; Larbalestier, D.C.; Jin, R.; Sefat, A.S.; McGuire, M.A.; Sales, B.C.; Christen, D.K. and Mandrus, D., *Small anisotropy, weak thermal fluctuations, and high field superconductivity in Co-doped iron pnictide Ba(Fe_{1-x}Co_x)₂As₂*, **Appl. Phys. Lett.**, **94**, 062511 (2009) [[read online](#)]
- Yamamoto, A.; Jiang, J.; Tarantini, C.; Craig, N.; Polyanskii, A.A.; Kametani, F.; Hunte, F.; Jaroszynski, J.; Hellstrom, E.E.; Larbalestier, D.C.; Jin, R.; Sefat, A.S.; McGuire, M.A.; Sales, B.C.; Christen, D.K. and Mandrus, D., *Evidence for electromagnetic granularity in the polycrystalline iron-based superconductor LaO_{0.89}F_{0.11}FeAs*, **Appl. Phys. Lett.**, **252**, 252501 (2009)
- Yang, K. and Halperin, B.I., *Thermopower as a Possible Probe of Non-Abelian Quasiparticle Statistics in Fractional Quantum Hall Liquids*, **Phys. Rev. B**, **79**, 115317 (2009) [[read online](#)]
- Yi, K.; Wang, X.; Emmett, M.R.; Marshall, A.G.; Stewart, M. and Roberts, T.M., *Dephosphorylation of MSP Fiber Protein 3 (MFP3) by PP2A During Cell Body Retraction in the MSP-Based Amoeboid Motility of Ascaris Sperm*, **Molecular Biology of the Cells**, **20**, 3200-3208 (2009)
- Yi, M.; Cross, T.A. and Zhou, H.-X., *Conformational heterogeneity of the M2 proton channel and a structural model for channel activation*, **P. Natl. Acad. Sci. U.S.A.**, **106**, 13311-13316 (2009) [[read online](#)]
- Ying, Y.A.; Xin, Y.; Clouser, B.W.; Hao, E.; Staley, N.E.; Myers, R.J.; Allard, L.F.; Fobes, D.; Liu, T.; Mao, Z.Q. and Liu, Y., *Suppression of Proximity Effect and the Enhancement of p-Wave Superconductivity in the Sr₂RuO₄-Ru System*, **Phys. Rev. Lett.**, **103**, 247004 (2009)
- Yuan, H.Q.; Singleton, J.; Balakirev, F.F.; Baily, S.A.; Chen, G.F.; Luo, J.L. and Wang, N.L., *Nearly isotropic superconductivity in (Ba,K)Fe₂As₂*, **Nature**, **457**, 565 (2009) [[read online](#)]
- Yuan, Z.Q.; Du, R.R.; Manfra, M.J.; Pfeiffer, L.N. and West, K.W., *Landau level spectrum in a two-dimensional hole gas in C-doped (100) GaAs/Al_{0.4}Ga_{0.6}As square quantum well*, **Appl. Phys. Lett.**, **94**, 052103 (2009)
- Yuen, J.D.; Menon, R.; Coates, N.E.; Namdas, E.B.; Cho, S.; Hannahs, S.T.; Moses, D. and Heeger, A.J., *Nonlinear transport in semiconducting polymers at high carrier densities*, **Nature Materials**, **8** (7), 572-575 (2009) [[read online](#)]
- Zeng, B.R.; Zhang, J.; Fu, R.; Cai, S.H. and Chen, Z., *Study on Structural Variation of Oxalate-oxodiperoxovanadate(V): From Solid State to Solution using NMR Spectroscopy and Theoretical Calculation*, **Inorg Chem Comm**, **12**, 1259-1262 (2009)
- Zhai, Y. and Cummer, S.A., *Fast tomographic reconstruction strategy for diffuse optical tomography*, **Optics Express**, **17** (7), 5285-5297 (2009) [[read online](#)]
- Zhai, Y.; Dixon, I.R. and Bird, M.D., *Mechanical Analysis of the Superconducting Outsert for the Series Connected Hybrid Magnets*, **IEEE Trans. Appl. Supercond.**, **19** (3), 1608 (2009)
- Zhang, C.; Wang, Y.; Deng, T.; Wang, X.; Biasatti, D.; Xu, Y. and Li, Q., *Expansion in the central Inner Mongolia during the latest Miocene and Early Pliocene*, **Earth Planet. Sci. Lett.**, **287**, 311-319 (2009)
- Zhang, F.; Robinette, S.L.; Bruschweiler-Li, L. and Bruschweiler, R., *Web server suite for complex mixture analysis by covariance NMR*, **Magnet. Reson. Chem.**, **47**, S118-S122 (2009)
- Zhang, H.-M.; Bou-Assaf, G.M.; Emmett, M.R. and Marshall, A.G., *Fast Reversed-Phase Liquid Chromatography to Reduce Back-Exchange and Increase Throughput in H/D Exchange Monitored by FT-ICR Mass Spectrometry*, **J. Am. Soc. Mass Spectr.**, **20** (3), 520-524 (2009)
- Zhang, L.; Camacho, J.; Cao, H.; Chen, Y.P.; Khodas, M.; Kharzeev, D.E.; Tselik, A.M.; Valla, T. and Zaliznyak, I.A., *Breakdown of the N=0 quantum Hall state in graphene: Two insulating regimes*, **Phys. Rev. B Rapid Commun.**, **80**, 241412 (2009) [[read online](#)]
- Zhang, L.; Murphy, C.S.; Kuang, G.C.; Hazelwood, K.L.; Constantino, M.H.; Davidson, M.W. and Zhu, L., *A fluorescent heteroditopic ligand responding to free zinc ion over six orders of magnitude concentration range*, **Chemical Communications**, **2009** (47), 7408-7410 (2009) [[read online](#)]
- Zherlitsyn, S.; Chiatti, O.; Sytcheva, A.; Wosnitza, J.; Zvyagin, A.A.; Zapf, V.S.; Jaime, M. and Paduan-Filho, A., *Ultrasonic investigation of NiCl₂-4SC(NH₂)₂ in the vicinity of the quantum critical points*, **J. Phys.: Conf. Series**, **145**, 012069 (2009)
- Zhou, H.; Maiorov, B.; Baily, S.A.; Dowden, P.C.; Kennison, J.A.; Stan, L.; Holesinger, T.G.; Jia, Q.X.; Foltyn, S.R. and Civale, L., *Thickness dependence of critical current density in YBa₂Cu₃O_{7-δ} films with BaZrO₃ and Y₂O₃ addition*, **Superconductor Science and Technology**, **22**, 085013 (2009) [[read online](#)]
- Zhou, H.D.; Lumata, L.L.; Kuhns, P.L.; Reyes, A.P.; Choi, E.S.; Dalal, N.S.; Lu, J.; Jo, Y.J.; Balicas, L.; Brooks, J.S. and Wiebe, C.R., *Ba₃NbFe₃Si₂O₁₄: A New Multiferroic with a 2D Triangular Fe³⁺ Motif*, **Chem. Mater.**, **21** (1), 156-159 (2009) [[read online](#)]
- Zhou, H.D.; Wiebe, C.R.; Jo, Y.J.; Balicas, L.; Urbano, R. R.; Lumata, L.L.; Brooks, J.S.; Reyes, A.P.; Qiu, Y.; Copley, J.R.D. and Gardner, J.S., *Chemical Pressure Induced Spin Freezing Phase Transition in Kagome Pr Langasites*, **Phys. Rev. Lett.**, **102**, 067203 (2009) [[read online](#)]
- Zhou, S.; Hoyos, J.A.; Dobrosavljevic, V. and Miranda, E., *Valence-bond theory of highly disordered quantum antiferromagnets*, **Europhys. Lett.**, **87**, 27003 (2009) [[read online](#)]
- Zhu, H.; Sambandamurthy, G.; Engel, L.W.; Tsui, D.C.; Pfeiffer, L.N. and West, K.W., *Pinning Mode Resonances of 2D Electron Stripe Phases: Effect of an In-Plane Magnetic Field*, **Phys. Rev. Lett.**, **102** (13), 136804 (2009)
- Zhu, H.; Sambandamurthy, G.; Engel, L.W.; Tsui, D.C.; Pfeiffer, L.N. and West, K.W., *Pinning mode resonances of two-dimensional electron stripe phases at high Landau levels*, **Physica B**, **404** (3-4), 367-369 (2009)
- Zhu, Y.; Hunte, F.; Zhuang, C.G.; Feng, Q.R.; Gan, Z.Z.; Xi, X.X.; Larbalestier, D.C. and Voyles, P.M., *MgO platelets and high critical field in MgB₂ thin films doped with carbon from methane*, **Superconductor Science and Technology**, **22**, 125001 (2009)
- Zikos, G.; Yang, K.; Bonesteel, N.E.; Hormozi, L. and Simon, S.H., *Braiding and Entanglement in Non-Abelian Quantum Hall States*, **Int. J. Mod. Phys. B**, **23**, 2727 (2009) [[read online](#)]
- Zorko, A.; Nellutla, S.; van Tol, J.; Brunel, L.C.; Bert, F.; Duc, F.; Trombe, J.-C. and Mendels, P., *Electron spin resonance investigation of the spin-1/2 kagome antiferromagnet ZnCu₃(OH)₆Cl₂*, **J. Physics: Conference Series**, **145**, 012014 (2009) [[read online](#)]
- Zvyagin, S.A.; Wosnitza, J.; Kolezhuk, A.K.; Zapf, V.S.; Jaime, M.; Paduan-Filho, A.; Glazkov, V.N.; Sosin, S.S. and Smirnov, A.I., *Low-energy excitations in DTN below T_c: ESR Studies*, **J. Phys. -Condens. Mat.**, **150**, 042244 (2009)

PRESENTATIONS, POSTERS & ABSTRACTS

This section lists invited and contributed talks and papers at conferences; papers in conference proceedings that were not peer-reviewed; posters; abstracts; and presentations at universities and public forums in 2009. At least 380 activities were reported this year.

- Acelz, A.A.; Kohama, Y.; Jaime, M.; Balicas, L.; Ninios, K.; Chan, H.B.; Dabkowska, H.A. and Luke, G.M., *Bose-Einstein Condensation of Triplons in $Ba_2Cr_2O_8$* , American Physical Society March Meeting, Pittsburgh, PA, March 16–20 (2009)
- Althaus, E.; Canzar, S.; Ehrler, C.; Emmett, M.R.; Karrenbauer, A.; Marshall, A.G.; Meyer-Baese, A.; Tipton, J.D. and Zhang, H.-M., *Discrete Fitting of HDX-Data of Overlapping Fragments*, 2009 Int. Conf. on Bioinformatics & Computational Biology (BIOCOMP '09), Las Vegas, NV, July 13-16 (2009)
- Andrade, E.; Miranda, E. and Dobrosavljevic, V., *Electronic Giffths Phase of a 2D Mott Transition*, poster presented at the conference on "Emergence of Inhomogeneous Phases in Strongly Correlated Electron Systems", Paris, France, June 30-July 3 (2009) [[read online](#)]
- Arenas, D.J.; Koukis, D.; Datta, S.; Cao, C.; Cheng, H.-P.; Tanner, D.B.; Hill, S.; Beedle, C.C. and Hendrickson, D.N., *Absorption spectrum of the single molecule magnet $[Ni(dbm)(MeOH)Cl]_4$* , American Physical Society March Meeting, Pittsburgh, PA, March (2009) [[read online](#)]
- Bai, H. (Hongyu); Bird, M.D.; Bole, S.T.; Cantrell, K.R.; Dixon, I.R.; Gavrilin, A.V.; Painter, T.A. and Xu, T., *Safety Protection of Series Connected Hybrid Cryogenic System*, Cryogenic Engineering and Int. Cryogenic Materials Conf., Tucson, AZ, June 28-July 02 (2009)
- Baily, S.A., *Vortex phases and dynamics of high temperature superconductors*, Sandia National Laboratories, Albuquerque, NM, August 25 (2009)
- Baily, S.A.; Kohama, Y.; Hiramatsu, H.; Maiorov, B.; Balakirev, F.F.; Hirano, M. and Hosono, H., *Upper Critical Field in Cobalt-doped $SrFe_2As_2$ Epitaxial Thin Films*, Materials Research Society Spring Meeting 2009, San Francisco, CA, April 14 (2009)
- Baily, S.A.; Kohama, Y.; Maiorov, B.; Balakirev, F.F.; Hiramatsu, H.; Hirano, M. and Hosono, H., *Pseudo-isotropic upper critical field in Co-doped $SrFe_2As_2$ epitaxial films*, Research Park, Los Alamos, NM, March 13 (2009)
- Baily, S.A.; Kohama, Y.; Maiorov, B.; Balakirev, F.F.; Hiramatsu, H.; Hirano, M. and Hosono, H., *Pseudo-isotropic upper critical field in cobalt-doped $SrFe_2As_2$ epitaxial films*, Career Fair, Los Alamos, NM, August 25 (2009)
- Baily, S.A.; Kohama, Y.; Maiorov, B.; Balakirev, F.F.; Hiramatsu, H.; Hirano, M. and Hosono, H., *Pseudo-isotropic upper critical field in cobalt-doped $SrFe_2As_2$ epitaxial films*, Materials Capability Review, Los Alamos, NM, May 7 (2009)
- Balicas, L., *Anisotropy and irreversibility line in 1111 Fe arsenide single-crystals*, 12th Int. Workshop on Vortex Matter in Superconductors, Lake Yamanaka, Japan, September (2009)
- Balicas, L., *High magnetic field torque magnetometry in $SmFeAsO_{1-x}F_x$ single crystals*, 9th Int. Conf. on Materials and Mechanisms of Superconductivity, Tokyo, Japan, September (2009)
- Balicas, L., *Transport and torque magnetometry in oxypnictide single crystals at high fields (invited talk)*, New Developments in Theory of Superconductivity, Institute for Solid State Physics, University of Tokyo, June (2009)
- Balicas, L., *Transport and torque magnetometry in oxypnictide single crystals at high fields (invited talk)*, Physics Department, University of Kyoto, Kyoto, Japan, July (2009)
- Barrios, M.N. and Van Sciver, S.W., *An Apparatus to Measure Thermal Conductivity of Spray-on Foam Insulation*, Cryogenic Engineering Conf., Tucson, AZ, July 1 (2009)
- Behnia, K., *Bismuth beyond the quantum limit*, ICAM workshop "Emergent Quantum Phenomena from the Nano to the Macro World", Cargèse, France, July 7-18 (2009)
- Behnia, K., *Bismuth beyond the quantum limit*, Int. Conf. on Research in High Magnetic Fields, RHMF 2009, Dresden, Germany, July 22-25 (2009)
- Behnia, K., *Bismuth beyond the quantum limit*, Swiss Workshop on Materials with Novel Electronic Properties, Les Diablerets, Switzerland, August 26-28 (2009)
- Besara, T.; Jain, P.; Kuhns, P.L.; Reyes, A.P.; Dalal, N.S.; Kroto, H.W. and Cheetham, A.K., *Investigation of the Order-Disorder Transition in the Hybrid Inorganic-Organic System $[(CH_3)_2NH_2Zn(HCOO)_3]$ by means of 1H NMR*, American Physical Society March Meeting, Pittsburgh, PA, March 16-20 (2009) [[read online](#)]
- Besara, T.; Jain, P.; Kuhns, P.L.; Reyes, A.P.; Dalal, N.S.; Kroto, H.W. and Cheetham, A.K., *NMR Detection of Glass Formation in Hybrid Perovskites*, Florida Annual Meeting and Exposition (FAME), ACS Florida Section, Orlando, FL, May 14-16 (2009)
- Besara, T.; Lumata, L.L.; Choi, K.-Y.; Reyes, A.P.; Kuhns, P.L.; Dalal, N.S.; Brooks, J.S.; Zhou, H.D. and Wiebe, C.R., *^{51}V NMR Investigation of the Quasi-1D Antiferromagnet $BaCo_2V_2O_8$: Is there a New Ordered Phase?*, American Physical Society March Meeting, Pittsburgh, PA, March 16-20 (2009) [[read online](#)]
- Beu, S.C.; Hendrickson, C.L. and Marshall, A.G., *Exchange of Axial and Radial Kinetic Energy During Ion Transfer Through a Multipole Ion Guide in a Strong Magnetic Field Gradient*, 57th Amer. Soc. Mass Spectrom. Annual Conf. on Mass Spectrometry & Allied Topics, Philadelphia, PA, May 31-June 5 (2009)
- Blakney, G.T.; Hendrickson, C.L. and Marshall, A.G., *Advanced Data Acquisition Strategy for a 14.5 T Hybrid Linear Ion Trap Fourier Transform Ion Cyclotron Resonance Mass Spectrometer*, 57th Amer. Soc. Mass Spectrom. Annual Conf. on Mass Spectrometry & Allied Topics, Philadelphia, PA, May 31-June 5 (2009)
- Bollinger, K.; Neumeier, J.J.; White, B. D.; Suzuki, Y.; Migliori, A.; Betts, J.J.; Sandim, H.R.Z. and dos Santos, C.A.M., *Anomalies in the bulk properties of single crystalline Niobium*, American Physical Society March Meeting, Pittsburgh, PA, March 10-20 (2009)
- Bonesteel, N.E., *Bond Fluctuations in Random Singlet Phases*, Microsoft, Station Q, University of California Santa Barbara, May 5 (2009)
- Bosque, E.; Hemmetti, A.M. and Van Sciver, S.W., *A Magnetic Suspension System for Measuring Drag of an Oscillating Sphere in Low Temperature Helium*, Cryogenic Engineering and Int. Cryogenic Materials Conf., Tucson AZ, June 28-July 2 (2009)

- Bou-Assaf, G.M.; Chamoun, J.E.; Emmett, M.R.; Fajer, P.G. and Marshall, A.G., *Advantages of Isotopic Depletion of Proteins in Hydrogen/Deuterium Exchange Monitored by Fourier Transform Ion Cyclotron Resonance Mass Spectrometry*, 7th N. Amer. Fourier Transform Mass Spectrometry Conf., Key West, FL, April 19-22 (2009)
- Bou-Assaf, G.M.; Chamoun, J.E.; Emmett, M.R.; Fajer, P.G. and Marshall, A.G., *Isotopic Depletion for the Structural Mapping of the Troponin Complex by Hydrogen/Deuterium Exchange Monitored by Fourier Transform Ion Cyclotron Resonance Mass Spectrometry*, 57th American Society for Mass Spectrometry Conf. on Mass Spectrometry and Applied Topics, Philadelphia, PA, May 31-June 4 (2009)
- Carpenter, C.; d'Albany, D.; Humayun, M. and Dixon, P., *An RET experience with geochemical analysis of Azorean lavas*, American Geophysical Union, Fall Meeting, San Francisco, CA, December 14-18 (2009); Published in **EOS Transactions of the American Geophysical Union**, **90** (52) (2009)
- Cheesman, A.W.; Inglett, P.W.; Turner, B.L. and Reddy, K.R., *Influence of decay continuum on phosphorus forms of plant litter in a subtropical freshwater marsh*, 2009 SWS-WWA-WBS Joint Meeting, Madison, WI, June 21-25 (2009)
- Chen, K.; McGill, S.A. and Xiong, P., *Molecular Modifications of the Electronic Characteristics of Carbon Nanotube Field-Effect Transistors*, American Physical Society March Meeting, Pittsburgh, PA, March 16-20 (2009)
- Cheng, M. and Ingersent, K., *Quantum phase transition in the XY-anisotropic Bose-Fermi Kondo model*, American Physical Society March Meeting, Pittsburgh, PA, March 16-20 (2009)
- Civale, L.; Maiorov, B.; Baily, S.A.; Zhou H.; Holesinger, T.G.; Usov, I.O.; Feldmann, D.M.; Foltyn, S.R.; Jia, Q. and Dowden, P., *Thermal Fluctuations and the Limits to Vortex Pinning in Superconductors*, Materials Research Society Spring Meeting 2009, San Francisco, CA, April 15 (2009)
- Coor, J.L.; Donoghue, J.F.; Wang, Y.; Das, O.; Kish, S.A.; Elsner, J.B.; Hu, X.; Niedoroda, A.W. and Ye, M., *Development of a long-term storm history for the northwest Florida coast using multiple proxies*, American Geophysical Union, Fall Meeting, San Francisco, CA, December 13-17 (2009); Published in **Eos, Transactions, Amer. Geophys. Union, Fall Meet. Suppl.**, **90** (52), 1109 (2009)
- Cotten, M.; Fu, R.; Gordon, E.D.; Daza, E.L.; Kozlova, A.S.; Hibbard, D.J.; Taylor, M.M.; Ditto, J.J. and Truong, M., *High-Resolution Solid-State NMR Structural and Topological Studies of Antimicrobial Piscidin Bound to Aligned Lipid Bilayers*, 50th Experimental Nuclear Magnetic Resonance Conf., Asilomar, CA, April (2009)
- Cotten, M.; Fu, R.; Wiczorek, W.; Baxter, M.; McGavin, J.; Sudheendra, U.S.; Gordon, E.D.; Hibbard, D.J. and Kozlova, A.S., *High Resolution Solid-State NMR Structural Studies of Two Piscidin Isoforms in Aligned Lipid Bilayers: Implications for Membrane Activity*, 2009 Eastern Analytical Symposium and Exposition, November (2009)
- Crooker, S.A., *Efficient electrical spin detection and spin noise spectroscopy*, Tohoku University, Sendai, Japan, December 9 (2009)
- Crooker, S.A., *Imaging spin injection and transport in semiconductor spintronic devices*, Optics Seminar-University of Oregon, Eugene, OR, February 2 (2009)
- Crooker, S.A., *Imaging the injection and flow of spin-polarized electrons in semiconductors*, University of Dortmund, Dortmund, Germany, October 7 (2009)
- Crooker, S.A., *Optical spectroscopy of magnetic semiconductors in pulsed magnetic fields to 89 Tesla*, 6th Int. Joint IMR Symposium on High Magnetic Field Spin Science in 100T, Tohoku University, December 8 (2009)
- Crooker, S.A., *Toward efficient electrical spin detection in lateral spin-transport devices*, SPINOS-2009, Salt Lake City, UT, February 4-7 (2009)
- Crooker, S.A., *Toward efficient electrical spin detection in lateral spin-transport devices*, Symposium on Spin Manipulation in Solid-State Systems, Wurzburg, Germany, October 8-9 (2009)
- Crooker, S.A., *Tunable magnetic exchange interactions in magnetically-doped core/shell nanocrystals*, Excited State Processes in Electronic and Bio-Nanomaterials, Santa Fe, NM, June 29-July 2 (2009)
- Cross, T.A.; Brey, W.W.; Sharma, M.; Qin, H.; Murray, D.; Hu, J. and Ni, D., *Mtb Membrane Proteins: A Potentially Novel Approach for Drug Screening*, Keystone Symposium: Tuberculosis: Biology, Pathology and Therapy, Keystone, SD, January (2009)
- Cross, T.A.; Brey, W.W.; Sharma, M.; Qin, H.; Murray, D.; Hu, J. and Ni, D., *Solid State NMR: A novel Approach for Membrane Protein Drug Screening*, Keystone Conference: Frontiers of NMR in Biology, Santa Fe, NM, February (2009)
- Cross, T.A.; Brey, W.W.; Sharma, M.; Qin, H.; Murray, D.; Hu, J. and Ni, D., *Solid State NMR: A Novel Approach for Membrane Protein Drug Screening*, Keyston Symposium: Frontiers of NMR in Biology, Santa Fe, NM, February (2009)
- Cross, T.A.; Sharma, M.; Yi, M.; Hu, J.; Li, C.; Luca, S.; Qin, H. and Zhou, H.-X., *Sorting Structural Reality from the Artifacts: In Search of Membrane Protein Functional Understanding*, Georgia-Tech Biotech Symposium, Atlanta, GA, November (2009)
- Cross, T.A.; Sharma, M.; Yi, M.; Hu, J.; Li, C.; Luca, S.; Qin, H. and Zhou, H.-X., *Sorting Structural Reality from the Artifacts*, Rocky Mountain Conference, Snowmass, CO, July (2009)
- Crosswhite, M.R. and Marshall, A.G., *High Performance Liquid Chromatography Electrospray Ionization Infrared Multiphoton Dissociation Fourier Transform Ion Cyclotron Resonance Mass Spectrometry of Valencia Orange Peel Extract: Probing for Structure*, 57th Amer. Soc. Mass Spectrom. Annual Conf. on Mass Spectrometry & Allied Topics, Philadelphia, PA, May 31-June 5 (2009)
- Daou, R.; Doiron-Leyraud, N.; LeBoeuf, D.; Li, S.; Laliberte, F.; Cyr-Choiniere, O.; Jo, Y.J.; Balicas, L.; Yan, J.-Q.; Zhou, J.-S.; Goodenough, J. and Taillefer, L., *Linear-T resistivity and change in Fermi surface at the pseudogap critical point of a high-TC superconductor*, American Physical Society March Meeting, Pittsburgh, PA, March 16-20 (2009)
- Das, O.; Wang, Y.; Donoghue, J.; Coor, J.; Kish, S.; Elsner, J.; Hu, X.; Niedoroda, A.; Ye, M. and Xu, Y., *Reconstruction of paleostorm history using geochemical proxies in sediment cores*, American Geophysical Union, Fall Meeting, San Francisco, CA, December 13-17 (2009); Published in **Eos, Transactions, Amer. Geophys. Union, Fall Meet. Suppl.**, **90** (52), 1105 (2009)
- Datta, S.; Liu, J.; Lawrence, J.; Beedle, C.C. and Hendrickson, D.N., *Anisotropic exchange in tetranuclear Co(II) complexes*, American Physical Society March Meeting, Pittsburgh, PA, March (2009) [[read online](#)]

- Davis, F.A.; Hirschmann, M.M. and Humayun, M., *The composition of low-degree partial melts of garnet peridotite at 3 GPa by modified iterative sandwich experiments (MISE)*, American Geophysical Union, Fall Meeting, San Francisco, CA, December 14-18 (2009); Published in *EOS Transactions of the American Geophysical Union*, **90** (52) (2009)
- Dobrosavljevic, V., *Coulomb Correlations and the Wigner-Mott Scenario for the 2D-MIT*, Condensed Matter Seminar, LPS, University of Paris, Sud, Orsay, France, June 26 (2009) [[read online](#)]
- Dobrosavljevic, V., *Coulomb Correlations and the Wigner-Mott Scenario for the 2D-MIT*, Condensed Matter Seminar, University of Wisconsin, Madison, WI, March 13 (2009) [[read online](#)]
- Dobrosavljevic, V., *Dynamical Mean-Field Theory Approaches to Interaction-Localization*, Condensed Matter Seminar, Department of Physics, Texas A&M University, College Station, TX, January 23 (2009) [[read online](#)]
- Dobrosavljevic, V., *Electronic Griffiths Phases and Quantum Criticality at the Metal-Insulator Transition*, Invited talk at the Princeton Center for Theoretical Sciences program on "Rare Fluctuations and Large Disorder in Quantum Systems", Princeton University, Princeton, NJ, September 24-25 (2009) [[read online](#)]
- Dobrosavljevic, V., *From Alchemy to Quantum Magic*, 2008 Prof. Marko Jaric Award Speech, University of Belgrade, Belgrade, Serbia, March 18 (2009) [[read online](#)]
- Dobrosavljevic, V., *Infinite Randomness Fixed Point of the Disordered Mott Transition?*, Invited talk at the "Symposium Workshop on Quantum Simulations", University of Warwick, Warwick, UK, August 23-28 (2009) [[read online](#)]
- Dobrosavljevic, V., *Quantum Griffiths Phases of Correlated Electrons*, Condensed Matter Seminar, Department of Physics, Rutgers University, Piscataway, NJ, March 11 (2009) [[read online](#)]
- Dobrosavljevic, V., *Quantum Griffiths Phases of Correlated Electrons*, Condensed Matter Seminar, Institute of Physics, Belgrade, Serbia, March 20 (2009) [[read online](#)]
- Dobrosavljevic, V., *Transport fingerprints of inherent phase separation in magnetically-doped 2DEG*, Invited talk at the "Telluride Workshop on Competing Interactions and Colossal Responses in Transition Metal Compounds", Telluride, CO, August 10-14 (2009) [[read online](#)]
- Donoghue, J.F.; Coor, J.L.; Wang, Y.; Das, O.; Kish, S.A.; Elsner, J.B.; Hu, X.; Niedoroda, A.W. and Ye, M., *Coastal lake record of Holocene paleo-storms from northwest Florida*, American Geophysical Union, 2009 Fall Meeting, San Francisco, CA, December 13-17 (2009); Published in *Eos, Transactions, Amer. Geophys. Union*, **90** (52), 1110 (2009)
- Dossey, A.T. and Edison, A.S., *Walkingsticks as Models for Chemical Biodiversity and Biosynthesis (Order Phasmatodea)*, American Society of Pharmacognosy (ASP) 50th Anniversary Annual Meeting, Honolulu, HI, USA, June 30 (2009)
- Dossey, A.T., *Insects and Chemical Ecology: Huge Potential for New Natural Product Discovery*, South East Regional Meeting of the American Chemical Society (SERMACS), San Juan, PR, USA, October 21-24 (2009) [[read online](#)]
- Drayss, M.; Blunk, D.; Dreiocker, F.; Purcell, J. M.; Hendrickson, C. L.; Marshall, A.G.; Oomens, J.; Armentrout, P.; Mookherjee, A. and Schäfer, M., *Investigation of [M+K]+ Amino Acid (Triply Substituted Amines) Molecular Ions in the Gas Phase: Molecular Modeling and Infrared Multiphoton Dissociation Spectroscopy (CO₂ Laser IRMPD and Free Electron Laser Experiments (FELIX))*, German Mass Spectrometry Soc. Mtg., Konstanz, Germany, March 8-11 (2009)
- Drayss, M.; Dreiocker, F.; Blunk D.; Purcell, J.M.; Hendrickson, C.L.; Marshall, A.G.; Oomens, J.; Mookherjee, A.; Armentrout, P.B. and Schaefer, M., *Potassium Affinity of Gas-Phase Amino Acids Determined by IRMPD (CO₂ and Free Electron Laser) and Molecular Modeling*, 57th Amer. Soc. Mass Spectrom. Annual Conf. on Mass Spectrometry & Allied Topics, Philadelphia, PA, May 31-June 5 (2009)
- Drichko, I.L.; Smirnov, I.Yu.; Suslov, A.V. and Mironov, O.A., *Giant positive magnetoresistance in p-Si/SiGe/Si quantum well in parallel magnetic field*, IX Russian Conf. on Semiconductors, Novosibirsk, September 28-October 3 (2009); Published in *Book of Abstracts*, 105 (2009)
- Drichko, I.L.; Smirnov, I.Yu.; Suslov, A.V. and Mironov, O.A., *High-frequency and static conductivity in the quantum well p-Si/SiGe/Si in in-plane magnetic field*, 35th Russian Meeting on Low Temperature Physics, Chernogolovka, September 29-October 2 (2009); Published in *Books of Abstracts*, 233-234 (2009)
- Drichko, I.L.; Smirnov, I.Yu.; Suslov, A.V.; Mironov, O.A. and Leadley, D.R., *Magnetoresistance and Acoustoelectric Effects in Dilute p-Si/SiGe in a Parallel and Tilted Magnetic Fields*, TIDS13 Workshop and Int. Conf. Transport in Interacting Disordered Systems, Rackeve, Hungary, August 31-September 5 (2009); Published in *Book of Abstracts*, 21 (2009)
- Du, R.R., *Topological Phases at 5/2 in Very High Electron Density Quantum Wells*, Int. Workshop on Quantum Topological Phases, Hong Kong, June 25 (2009)
- Du, R.R., *Topological Phases in InAs/GaAs Quantum Wells*, Int. Workshop on Quantum Matters, Heng Zhou, China, October (2009)
- Du, X.; Das, R. and Odom, A.L., *Can submarine groundwater discharge be a major source of mercury input to north Gulf of Mexico?*, AGU Fall Meeting, San Francisco, CA, December (2009); Published in *Eos Trans. AGU, Fall Meet. Suppl.*, **90** (52) (2009)
- Edison, A.S.; Ajredini, R.; Robinette, S.L.; Rasheed, H.; Kaplan, F.; Albrown, H.T.; Zhang, F. and Brusweiler, R., *High Sensitivity NMR and Mixture Analysis for Nematode Behavioral Metabolomics*, 50th Experimental Nuclear Magnetic Resonance Conf., Asilomar, CA, March 29-April 3 (2009)
- Edison, A.S.; Cross, T.A.; Long, J.R.; Walter, G.A.; Hill, S. and Marshall, A.G., *Chemistry and Biology at the National High Magnetic Field Laboratory*, 50th ENC Conference, Pacific Grove, CA, March (2009)
- Emmett, M.R.; He, H.; Marshall, A.G.; Nilsson, C.L.; Groves, M. and Conrad, C.A., *Lipidomic Analysis of Cancer: Cell Culture to Patient Biologicals*, 7th N. Amer. Fourier Transform Mass Spectrometry Conf., Key West, FL, April 19-22 (2009)
- Emmett, M.R.; He, H.; Zhang, H.-M.; Blakney, G.T. and Marshall, A.G., *Biological Applications of FT-ICR Mass Spectrometry*, Athens/Atlanta Mass Spectrometry Discussion Group, Athens, GA, January 13 (2009)
- Emmett, M.R.; Nilsson, C.L.; He, H.; Marshall, A.A.; Kroes, R.A.; Schmidt, M.A.; Ji, Y.; Colman, H.; Lang, F.; Conrad, C.A. and Moskal, J.R., *Cellular Glycolipids in Cultured Glioblastoma multiforme Brain Tumor Cells*, USA HUPO 2009, San Diego, CA, February 22-25 (2009)

- Emmett, M.R.; Zhang, H.-M.; Frantom, P.A.; Blanchard, J.S. and Marshall, A.G., *Identification of an Allosteric Pathway in the Regulation of α -Isopropylmalate Synthase from Mycobacterium Tuberculosis by Solution-phase H/D Exchange FT-ICR MS*, 57th Amer. Soc. Mass Spectrom. Annual Conf. on Mass Spectrometry & Allied Topics, Philadelphia, PA, May 31-June 5 (2009)
- Fanelli, V.R., *Thesis: Inelastic neutron scattering study of the intermediate valence compounds CePd₃ and YbAl₃*, University of California, Irvine, Irvine, CA, February (2009)
- Fanelli, V.R.; Lawrence, J.M.; Bauer, E.D.; Wang, C.H.; Christianson, E.D.; McClellan, K.J.; Geremychkin, E.A. and Osborn, R., *Magnetic scattering in the 4f-Intermediate valence compound CePd₃*, Int. Conf. on Neutron Scattering ICNS 2009, Knoxville, TN, May 3-7 (2009)
- Farrell, E.O.; Tompsett, D.A.; Sebastian, S.E.; Harrison, N.; Capan, C.; Balicas, L.; Kuga, K.; Matsuo, T.; Tomonaga, M.; Nakatsuji, S.; Csanyi, G.; Fisk, Z. and Sutherland, M.L., *The role of f-electrons at the Fermi surface of the heavy fermion superconductor b-YbAlB₄*, American Physical Society March Meeting, Pittsburgh, PA, March 16-20 (2009)
- Figueiroa, S.M.; Rich, N.J.; VanLandingham, J.W.; Schepkin, V.D. and Levenson, C.W., *Vitamin D improves progesterone-mediated reductions in edema following traumatic brain injury*, Experimental Biology, New Orleans, LA, April 18-22 (2009); Published in **Proceedings EB - 2009 (B91 904.1)** (0)
- Foroutan, P.; Cappendijk, S.L.T. and Grant, S.C., *A Volumetric Analysis of the Adult Zebra Finch Brain after Single and Repetitive Ecstasy Exposure*, 17th Joint Annual Int. Society for Magnetic Resonance in Medicine and European Society for Magnetic Resonance in Medicine and Biology Conf., Honolulu, HI, April 17-24 (2009)
- Foroutan, P.; Masad, I.S. and Grant, S.C., *Contrast Enhancement in Preserved Tissue Utilizing Low Temperatures at High Magnetic Fields*, 50th Experimental NMR Conf., Asilomar, CA, March 29-April 1 (2009)
- Fortune, N.A.; Hannahs, S.T.; Takano, Y.; Yoshida, Y.; Sherline, T.; Wilson-Muenchow, A.A.; Ono, T. and Tanaka, H., *Field-Induced Quantum Phase Transitions in the Spin-1/2 Triangular-Lattice Antiferromagnet Cs₂CuBr₄*, Int. Conf. on Magnetism, Karlsruhe, Germany, July 26-31 (2009)
- Fortune, N.A.; Wilson-Muenchow, A.A.; Hannahs, S.T.; Takano, Y.; Yoshida, Y.; Sherline, T.; Ono, T. and Tanaka, H., *Cascade of Quantum Phase Transitions in the Spin-1/2 Triangular-Lattice Antiferromagnet Cs₂CuBr₄*, American Physical Society March Meeting, Pittsburg, PA, March 16-20 (2009)
- Frantom, P.A.; Zhang, H.-M.; Emmett, M.R.; Marshall, A.G. and Blanchard, J.S., *Dynamically Driven Allostery in a Multidomain Enzyme: Identification of a Complete Allosteric Network*, 21st Enzyme Mechanisms Conf., Tucson, AZ, January 3-6 (2009)
- Frantom, P.A.; Zhang, H.-M.; Emmett, M.R.; Marshall, A.G. and Blanchard, J.S., *Identification of a Complete Allosteric Pathway in a Multidomain Enzyme: Solution-Phase H/D Exchange Monitored by FT-ICR Mass Spectrometry*, 7th N. Amer. Fourier Transform Mass Spectrometry Conf., Key West, FL, April 19-22 (2009)
- Froelich, P.N.; Landing, W.; Artz, R.; Cohen, M.; Luke, W.; Huey, G. and Hynes, A., *Southeastern Atmospheric Mercury Consortium: Flight Plans over Northern Gulf Coasts and Florida*, Northern Gulf Institute Conf., Mobile, AL, May 20-21 (2009); Published in **NGI Conference Abstracts, 2009** (1), 15 (2009)
- Fu, R., *Structural and Dynamic Characterization of Membrane Bound Peptides in Hydrated Lipid Bilayers using High-Resolution Solid-State NMR*, Department of Chemistry, Xiamen University, Xiamen, China, May 5 (2009)
- Fu, R., *Structural and Dynamic Characterization of Membrane-Bound Peptides in Hydrated Lipid Bilayers using High-Resolution Solid-State NMR at High Fields*, 13th Int. Beijing Conf. and Exhibition on Instrumental Analysis (BCEIA 2009), Beijing, China, November 25-28 (2009)
- Fu, R.; Gordon, E.D.; Daza, E.L.; Kozlova, A.S.; Hibbard, D.J.; Taylor, M.M.; Ditto, J.J.; Truong, M. and Cotten, M., *High-Resolution NMR Structure of Piscidin in Aligned Lipid Bilayers: Implications for Antimicrobial Mode of Action*, 53d Annual Biophysical Society Meeting, March (2009)
- Gan, Z.; Gor'kov, P.; Brey, W.; Sideris, P.J. and Grey, C.P., *Enhancing MQMAS of Low-g Quadrupolar Nuclei using High B₀ and B₁ Fields*, ENC, Asilomar, CA, March 29-April 4 (2009)
- Gavrilin, A.V.; Bai, H.; Bird, M.D. and Dixon, I.R., *Observations from the Analysis of Thermohydraulic Behavior of the Series-Connected Hybrid Magnets Superconducting Outserts*, 2009 Cryogenic Engineering and Int. Cryogenic Materials Conf., Tucson, AZ, June 28-July 02 (2009)
- Gebre, T.; Tokumoto, T.; Cherian, J.; McGill, S.A.; Tozer, S.; Palm, E.; Murphy, T. and Wiebe, C.R., *Optical Study of the Heavy Fermion Superconductor CeCoIn₅*, American Physical Society March Meeting, Pittsburgh, PA, March 16-20 (2009)
- Gokmen, T.; Padmanabhan, M. and Shayegan, M., *Piezoresistance and Metal Insulator Transition of Composite Fermions at $\nu = 3/2$* , American Physical Society March Meeting, Pittsburgh, PA, March 17 (2009) [[read online](#)]
- Gor'kov, L.P. and Teitel'baum, G.B., *Microscopical Phase Separation in Iron Pnictides: What is in Common to Cuprates?*, International Conference on Magnetism ICM 2009, Karlsruhe, Germany, July 26-31 (2009)
- Gor'kov, P.; Qian, C.; Beck, B.; Clark, D.; Masad, I.; Schepkin, V.; Grant, S. and Brey, W., *A Modular MRI Probe Design for Large Rodent Neuroimaging at 21.1 T (900 MHz)*, ENC, Asilomar, Pacific Grove, CA, March 29-April 3 (2009)
- Graf, D.; Stillwell, R.; Murphy, T.P.; Park, J.-H.; Kano, M.; Palm, E.C.; Schlottmann, P.; Cooley, J.; Lashley, J.; Willitt, J. and Tozer, S.W., *dHvA Measurements of α -Uranium at Ambient Pressure*, Research at High Magnetic Fields, Dresden, Germany, July 22-25 (2009)
- Gurevich, A. and Vinokur, V., *Size effects in a virtual Berezinskii-Kosterlitz-Thouless state of superconducting films*, American Physical Society March Meeting, Pittsburgh, PA, March 12-16 (2009)
- Gurevich, A., *Designing superconducting materials for applications*, School for New Superconducting Materials, University of Santa Barbara, CA, August 7 (2009)
- Gurevich, A., *High-field superconductivity in oxypnictides*, MRS Meeting, San Francisco, CA, April 14 (2009)
- Gurevich, A., *Making cuprates and other new superconductors suitable for applications*, Materials and Mechanisms of Superconductivity, Tokyo, Japan, September 11 (2009)
- Gurevich, A., *Making cuprates and other new superconductors suitable for applications*, University of Florida, Department of Physics, Gainesville, FL, September 28 (2009)

- Gurevich, A., *Oxyprictide superconductors at high magnetic fields*, 2009 Spring Meeting of Materials Research Society, San Francisco, CA, April 14-16 (2009)
- Gurevich, A., *Pnictides at high magnetic fields*, KITP School on High-Tc Superconductivity, Santa Barbara, CA, August 12 (2009)
- Gurevich, A., *Superconductivity in oxyprictides*, Old Dominion University, Physics Colloquium, Norfolk, VA, March 31 (2009)
- Gurevich, A., *Tailoring designer superconductors for power applications*, Int. Workshop on the Search for New Superconductors, Shonan Village Center, Hayama, Japan, May 12-16 (2009)
- Gurevich, A., *Ultrafast dynamics of vortex penetration and nonlinear surface resistance under strong rf fields*, 12th Int. Workshop on Vortex Matter in Superconductors, Lake Yamanaka, Japan, September 12-16 (2009)
- Hannahs, S.T., *Magnets: Myths and Legends*, National High Magnetic Field Laboratory, Tallahassee, FL, April 23 (2009) [[read online](#)]
- Hayes, S.E. (Sophia); Crooker, S.A. and Stanton, C.J., *OPNMR of GaAs: Roadmaps for New Routes through the Opto-Electronic 'Landscape'*, Gordon Research Conference on Magnetic Resonance, Biddeford, ME, June (2009)
- Hayes, S.E.(Sophie); Crooker, S.A. and Stanton, C.J., *A New Model of Optically-pumped NMR in Direct-Gap Semiconductors*, Alpine Conference on Solid-state NMR, Chamonix, France, September (2009)
- He, H.; Emmett, M.R.; Nilsson, C.L.; Kroes, R.A.; Marshall, A.G.; Moskal, J.R.; Colman, H. and Conrad, C.A., *Cellular Glycolipids in Cultured Glioblastoma Multiforme Brain Tumor Cells*, Sanibel Conf. on Mass Spectrometry: Lipidomics and Lipids in Mass Spectrometry, St. Petersburg, FL, January 23-26 (2009)
- He, H.; Emmett, M.R.; Nilsson, C.L.; Marshall, A.G.; Colman, H. and Conrad, C.A., *Endogenous Sulfated Glycosphingolipids in NSC11 Glioblastoma Cancer Stem Cells*, 7th N. Amer. Fourier Transform Mass Spectrometry Conf., Key West, FL, April 19-22 (2009)
- He, H.; Emmett, M.R.; Nilsson, C.L.; Marshall, A.G.; Colman, H. and Conrad, C.A., *Identification of a Class of Endogenous Sulfated Glycosphingolipids in NSC11 Glioblastoma Cancer Stem Cells*, 57th Amer. Soc. Mass Spectrom. Annual Conf. on Mass Spectrometry & Allied Topics, Philadelphia, PA, May 31-June 5 (2009)
- He, H.; Emmett, M.R.; Nilsson, C.L.; Marshall, A.G.; Kroes, R.A.; Moskal, J.R.; Colman, H. and Conrad, C.A., *Response of the Cellular Polar Lipidome to Phenotype Change in Cultured Glioblastoma Multiforme Cancer Stem Cells and Tumor Cells*, 2nd Moffitt Symp. on Mass Spectrometry (MSMS), Tampa, FL, February 11-12 (2009)
- Headley, J.V.; Peru, K.M.; Armstrong, S.A.; Han, X.; Martin, J.W.; Mapolelo, M.M.; Smith, D.F.; Rodgers, R.P. and Marshall, A.G., *MS Characterization of Plant Mediated Changes of Oil Sands Naphthenic Acids*, Western Canada Trace Organic Workshop 2009, Winnipeg, Manitoba, Canada, May 4-6 (2009)
- Hellstrom, E.E.; Jiang, J.; LoSchiavo, M.; Shen, T.; Trociewitz, U.; Yamamoto, A.; Schwartz, J. and Larbalestier, D., *Integrated Understanding of Processing and Properties of Bi₂Sr₂CaCu_xO_x (Bi2212) Round Wire*, 2009 CEC/ICMC Conf., Tucson AZ, June 29-July 2 (2009)
- Hemmati, A.M.; Bosque, E.; Fuzier, S. and Van Sciver, S.W., *Drag Measurement on an Oscillating Sphere in Helium II*, Cryogenic Engineering and Int. Cryogenic Materials Conf., Tucson AZ, June 28-July 2 (2009)
- Henderson, M.; del Barco, E.; Koo, C.; Hill, S.; Feng, P. L.; Hendrickson, D. N. and Nakano, M., *Magnetization studies of a new single molecule magnet [Net₄]3[Mn₃Zn₂(salox)3O(N₃)6Br₂]*, American Physical Society March Meeting, Pittsburgh, PA, March (2009) [[read online](#)]
- Hendrickson, C.L.; Beu, S.C.; Blakney, G.T.; Kaiser N.K.; McIntosh, D.G.; Quinn, J.P. and Marshall, A.G., *Optimized Cell Geometry for Fourier Transform Ion Cyclotron Resonance Mass Spectrometry*, Amer. Soc. Mass Spectrom. Annual Conf. on Mass Spectrometry & Allied Topics, Philadelphia, PA, May 31-June 5 (2009)
- Henriksen, E.A.; Cadden-Zimansky, P.; Jiang, Z.; Tung, L.-C.; Schwartz, M.E.; Takita, M.; Li, Z.Q.; Wang, Y.-J.; Kim, P. and Stormer, H.L., *Cyclotron Resonance in Graphene*, Electronic Properties of 2-Dimensional Systems 18 (EP2DS-18), Kobe, Japan, July 19-24 (2009)
- Hernandez-Maldonado, A.J., *Separation of CO₂ from Light Gas Mixtures using Alkaline Earth Metal-Exchanged Silicoaluminophosphate Nanoporous Sorbents*, Technical Interchange Meeting on the Development of Loop Closure Technologies, NASA Marshall Space Flight Center, Huntsville, AL, August 17-20 (2009)
- Hernandez-Maldonado, A.J., *Novel Nanoporous Materials for Catalytic and Adsorption Applications*, NHMFL, Florida State University, Tallahassee, FL, June 15 (2009)
- Hibbard, D.J. and Cotten, M., *Determination of the membrane-bound structure of the antimicrobial peptide piscidin: Molecular biology and biochemical approaches*, 237th American Chemical Society National Meeting, March (2009)
- Hill, S., *Beyond the giant spin approximation: the view from EPR*, Symposium on Spin Physics and Nanomagnetism, Lehman College, New York, March 13-14 (2009) [[read online](#)]
- Hill, S., *Beyond the giant spin approximation: the view from EPR*, University of Valencia, Department of Chemistry, Valencia, Spain, June 12 (2009)
- Hill, S., *EPR at the National High Magnetic Field Laboratory: Shameless Advertising*, 3rd North America-Greece-Cyprus Workshop in Paramagnetic Materials, Protaras, Cyprus, June 15-19 (2009) [[read online](#)]
- Hill, S., *Microwave Spectroscopy of Organic Superconductors and Conductors*, 429 WE-Heraeus Seminar, Microwaves for Condensed Matter Physics, Physikzentrum Bad Honnef (Germany), April 5-8 (2009) [[read online](#)]
- Hill, S., *Single-Molecule Magnets: Insights from High-Field EPR*, North Carolina State University, Raleigh, NC, September 25 (2009)
- Hill, S.; Murugesu, M. and Christou, G., *Angle-Swept High-Field EPR: Application to Studies of Single Crystal Samples Containing Low-Symmetry Magnetic Species*, Southeastern Magnetic Resonance Conf., Vanderbilt University, Nashville, TN, November 4-6 (2009)
- Hoch, M.J.R., *Nanoscale phase separation and spin dynamics in colossal response transition metal oxides*, University of Florida, Physics Department, Gainesville, FL, November 2 (2009)
- Hoch, M.J.R.; Kuhns, P.L.; Moulton, W.G.; Reyes, A.P.; Lu, J. and Mitchell, J.F., *Anomalous nuclear relaxation in the ferromagnetic phase of the bilayered manganite La_{1.2}Sr_{1.8}Mn₂O₇*, American Physical Society March Meeting, Pittsburgh, PA, March 16-20 (2009) [[read online](#)]

- Hoch, M.J.R.; Smith, R.S.; Kuhns, P.L.; Moulton, W.G.; Reyes, A.P.; Boebinger, G.S.; Mitchell, J.F. and Leighton, C., *The electronic properties of cobaltites: insights from magnetic resonance*, Workshop on Competing Interactions and Colossal Responses in Transition Metal Compounds, Telluride, CO, August 10-14 (2009)
- Hockaday, W.C.; Hatcher, P.G.; Purcell, J.M.; Marshall, A.G.; Li, Q. and Masiello, C.A., *Fourier Transform Mass Spectrometry for the Study of Organic Matter Molecular Dynamics in Aquatic Ecosystems*, 94th Ecological Society of America Annual Mtg., Albuquerque, NM, August 2-7 (2009)
- Hoffman, N.W.; Stenson, A.C.; Sykora, R.E.; Traylor, R.K.; Wicker, B.F.; Riley, S.; Dixon, D.A. Jr.; Marshall, A.G.; Kwan, M.L. and Schroder, P., *Using Collision-Induced-Dissociation Mass Spectrometry to Predict Solution-Phase Relative Affinities of Unidentate Ligands for a Pd(II) Pincer Cation*, 41st Amer. Chem. Soc. Central Regional Mtg, Cleveland, OH, May 20-23 (2009)
- Huang, S.; Humayun, M.; Downes, H.; Singletary, S.; Van Orman, J.A. and Jacobsen, S.B., *Petrogenesis of augite-bearing ureilites: A LA-ICP-MS approach*, Lunar & Planetary Science Conf. XL, The Woodlands, TX, March 23-27 (2009) [[read online](#)]
- Humayun, M. and Huang, S., *Low-level Magnesium isotopic analysis for the Genesis Mission*, Lunar & Planetary Science Conf. XL, The Woodlands, TX, March 23-27 (2009) [[read online](#)]
- Humayun, M., *Osmium isotopic evolution in cumulate piles at the Core-Mantle Boundary*, American Geophysical Union, Fall Meeting, San Francisco, CA, December 14-18 (2009); Published in *EOS Transactions of the American Geophysical Union*, **90** (52) (2009)
- Humayun, M.; Keil, K. and Bischoff, A., *Siderophile elements in metal from Northwest Africa 2526, an enstatite chondrite partial melt residue*, Lunar & Planetary Science Conf. XL, The Woodlands, TX, March 23-27 (2009) [[read online](#)]
- Hunte, F.; Jaroszynski, J.; Gurevich, A.; Larbalestier, D.C.; Zhu, Y.; Voyles, P.M.; Xi, X.X.; Chen, K.; Baily, S.; Balakirev, F.; Zhuang, C.G.; Feng, Q.R. and Gan, Z.Z., *Upper critical field study of CH₄ HPCVD carbon-doped MgB₂*, American Physical Society March Meeting, Pittsburgh, PA, March 19 (2009)
- Imazawa, T.; Tsujii, H.; Kamizawa, T.; Inoue, K.; Takano, Y. and Hosokoshi, Y., *Specific Heat of the Organic Triradical BIPNNBNO Comprising S=1 and S=1/2 Spins*, 48th Annual Meeting of the Society of Electron Spin Science and Technology, Kobe, Japan, November 10-12 (2009)
- Imazawa, T.; Tsujii, H.; Kamizawa, T.; Inoue, K.; Takano, Y. and Hosokoshi, Y., *Specific Heat of the Organic Triradical BIPNNBNO Comprising S=1 and S=1/2 Spins*, The 3rd Japanese-Russian Workshop on Open Shell Compounds and Molecular Spin Devices, Awaji Island, Japan, November 15-18 (2009)
- Ingersent, K. and Duru, A., *Frustration of dissipation in a spin-boson model*, American Physical Society March Meeting, Pittsburgh, PA, March 16-20 (2009)
- Ingersent, K., *NRG with bosons: The good, the bad, and the computationally ugly*, Workshop on Decoherence, Correlations and Spin Effects in Nanostructured Materials, Vina del Mar, Chile, January 4-6 (2009)
- Jaime, M., *Critical properties at the field-induced BEC of magnons in NiCl_{2-x}SC(NH₂)₂*, Int. Conf. on Magnetism 2009, Karlsruhe, Germany, July (2009)
- Jaime, M., *Exotic phases flourish in frustrated quantum magnets at high magnetic fields*, XXXII ENFMC, Aguas de Linoia, Brazil, May (2009)
- Jaroszynski, J.; Hunte, F.; Balicas, L.; Jo, Y.-J.; Raicevic, I.; Gurevich, A.; Larbalestier, D.C.; Balakirev, F.F.; Fang, L.; Cheng, P.; Jia, Y. and Wen, H.H., *Upper critical fields of NdFeAsO_{0.7}F_{0.3} single crystal*, American Physical Society March Meeting, Pittsburgh, PA, March 16-20 (2009)
- Jiang, J.; Trociewitz, U.; Shen, T.; Yamamoto, A.; Griffin, V.S.; Craig, N.C.; Kametani, F.; Schwartz, J.; Hellstrom, E.E. and Larbalestier, D.C., *Filament Bridging and Connectivity in Bi-2212 Round Wire*, 2009 CEC-ICMC, Tucson, AZ, June 29-July 2 (2009)
- Jo, Y.-J.; Liu, R. H.; Chen, H.; Chen, X.H. and Balicas, L., *Unconventional magnetic field-temperature superconducting phase-diagram in Co doped BaFe₂As₂*, American Physical Society March Meeting, Pittsburgh, PA, March 16-20 (2009)
- Juyal, P.; McKenna, A.M.; Rodgers, R.P. and Marshall, A.G., *Advances in Heteroatom Speciation in Crude Oil by Ultrahigh Resolution Fourier Transform Ion Cyclotron Resonance Mass Spectrometry*, 10th Int. Conf. on Petroleum Phase Behaviour and Fouling, Rio de Janeiro, Brazil, June 14-18 (2009)
- Juyal, P.; McKenna, A.M.; Rodgers, R.P. and Marshall, A.G., *Ionization Techniques and Reagents for Improved Heteroatom Speciation in Crude Oils by Ultrahigh-Resolution FT-ICR MS*, 57th Amer. Soc. Mass Spectrom. Annual Conf. on Mass Spectrometry & Allied Topics, Philadelphia, PA, May 31-June 5 (2009)
- Kaczorowska, M.A.; Hotze, A.C.G.; Hannon, M.J.; Kaiser, N.K.; Hendrickson, C.L.; Marshall, A.G. and Cooper, H.J., *Electron Capture Dissociation of Metallo-Supramolecular Complexes*, 7th N. Amer. Fourier Transform Mass Spectrometry Conf., Key West, FL, April 19-22 (2009)
- Kaiser, N.K.; Quinn, J.P.; Blakney, G.T.; Hendrickson, C.L. and Marshall, A.G., *Design and Performance of a Novel 9.4 Tesla FT-ICR Mass Spectrometer for Proteome and Petroleum Analysis*, 57th Amer. Soc. Mass Spectrom. Annual Conf. on Mass Spectrometry & Allied Topics, Philadelphia, PA, May 31-June 5 (2009)
- Kaiser, N.K.; Quinn, J.P.; Blakney, G.T.; McIntosh, D.G.; Hendrickson, C.L. and Marshall, A.G., *Design and Performance of a Novel 9.4 Tesla FT-ICR Mass Spectrometer for Proteome and Petroleum Analysis*, 7th N. Amer. Fourier Transform Mass Spectrometry Conf., Key West, FL, April 19-22 (2009)
- Kang, W.; Jo, Y.J. and Choi, E.S., *Magnetization investigation of field-induced spin-density-waves*, Int. Conf. on Magnetism 2009, Karlsruhe, Germany, July 28 (2009)
- Kaur, N.; Preamplume, G.; Dalal, N.; Kumar, A.; Kim, Y.H.; Takano, Y.; Nellutla, S.; Jo, Y.J. and Balicas, L., *Magnetic-Field-Driven Quantum Criticality of Two-Dimensional Square-Lattice Antiferromagnet Cr(dien)(O₂)₂·H₂O*, American Physical Society March Meeting, Pittsburgh, PA, March 16-20 (2009)
- Kellie, J.F.; Lee, J.E.; Tran, J.C.; Ahlf, D.; Thomas, H.M.; Vellaicham, A.; Tipton, J.D.; Marshall, A.G. and Kelleher, N.L., *A New Realm for Protein Quantitation: Reproducibility and Modification Occupancy using Label-Free Top Down Mass Spectrometry*, 57th ASMS Conf. on Mass Spectrometry & Allied Topics, Philadelphia, PA, May 31-June 4 (2009)

- Kim, J.W.; Chun, S.H.; Kim, S.H.; Kim, K.H.; Jo, Y.J.; Balicas, L.; Choi, Y.J.; Cheong, S.-W.; Balakirev, F. and Harrison, N., *Electric polarization reversal under high magnetic field in square lattice antiferromagnet $B_2CoGe_2O_7$* , American Physical Society March Meeting, Pittsburgh, PA, March 16-20 (2009)
- Knowles, E.S.; Pajerowski, D.M.; Xia, J.S.; Yin, L.; Meisel, M.W. and Zheng, L.-M., *Characterization of Novel Metal Monophosphonate Magnetic Dimers*, Florida Inorganic and Materials Symposium (FIMS), Gainesville, FL, October 2-3 (2009)
- Koo, C.; Feng, P.L.; Henderson, J.J.; del Barco, E.; Hendrickson, D.N. and Hill, S., *High frequency electron paramagnetic resonance investigation of modulated Mn_3Zn_2 single-molecule magnets*, Florida Inorganic Mini-Symposium, Gainesville, FL, October 2-3 (2009)
- Koo, C.; Hill, S.; Samulon, E. and Fisher, I. R., *High-Frequency EPR Studies of the Antiferromagnetic Spin Dimer Compound $Ba_3Mn_2O_8$* , American Physical Society March Meeting, Pittsburgh, PA, March (2009) [[read online](#)]
- Kozlova, A.S. and Cotten, M., *Characterization of Hydrogen/Deuterium Exchange in the Amphipathic Helices of Piscidin 1 and 3*, 237th American Chemical Society National Meeting, March (2009)
- Krzystek, J., *Probing magnetic anisotropy of transition metal complexes using High-Frequency and -Field EPR*, Department of Chemistry, Graduate School of Science and Technology, Niigata University, Niigata, Japan, August 4 (2009)
- Krzystek, J., *Probing magnetic anisotropy of transition metal complexes using High-Frequency and -Field EPR*, Department of Chemistry, Okayama University, Okayama, Japan, July 21 (2009)
- Krzystek, J., *Probing magnetic anisotropy of transition metal complexes using High-Frequency and -Field EPR*, Department of Material and Biological Chemistry, Yamagata University, Yamagata, Japan, August 3 (2009)
- Krzystek, J., *Probing magnetic anisotropy of transition metal complexes using High-Frequency and -Field EPR*, School of Science and Technology, Kwansei Gakuin University, Sanda, Japan, July 22 (2009)
- Krzystek, J.; Ozarowski, A. and Telsler, J., *Cobalt(II) "Scorpionate" Complexes as Models for Co-substituted Zinc Enzymes: Electronic Structure Investigation by High-Frequency and -Field EPR Spectroscopy*, 14th Int. Conf. on Bioinorganic Chemistry, Nagoya, Japan, July 25-30 (2009)
- Krzystek, J.; Ozarowski, A.; Smirnov, D.; Englad, J.; Ray, K. Que Jr. and Telsler, J., *Probing magnetic and electronic properties of integer-spin states of ferrous (FeII) and ferryl (FeIVO) coordination complexes using high-frequency and -field EPR*, Zing Conf. on Coordination Chemistry, Antigua, March 15-18 (2009)
- Krzystek, J.; Ozarowski, A. and Telsler, J., *Cobalt(II) "Scorpionate" Complexes as Models for Co-Substituted Zinc Enzymes: Electronic Structure Investigation by High-Frequency and -Field EPR Spectroscopy*, 22nd Int. Conf. on Coordination and Bioinorganic Chemistry, Smolenice, Slovakia, June 7-12 (2009)
- Larbaestier, D., *Is it possible to get what we really want from YBCO -- a multifilament, preferably a round-wire conductor?*, CCA '09 Coated Conductors for Applications, Barcelona, Spain, November 22-24 (2009)
- Larbaestier, D., *Pushing the still unknown of Nb_3Sn - a strand level view*, ITER Strand and Cable Review meeting, Cadarache, France, March 24 (2009)
- Larbaestier, D., *Recent Adventures in HTS at the NHMFL*, Association Francais du Froid, Aussois, France, March 25 (2009)
- Larbaestier, D., *Superconductors for future high field use: Why not multifilamentary YBCO - or something even better?*, Institute for Technical Physics Colloquium, Research Center Karlsruhe, Germany, September 8 (2009)
- Larbaestier, D.; Trociewitz, U.; Weijers, H.W.; Markiewicz, W.D.; Noyes, P.; Viouchkov, Y.; Jaroszynski, J. and Xu, A., *High Field Magnets with YBCO coated conductors*, CCA '09 Coated Conductors for Applications, Barcelona, Spain, November 22-24 (2009)
- Larbaestier, D.C., *A reflection on the influence of Masaki Suenaga on the understanding and applications of the A15 compounds and other low temperature superconductors*, Int. Symposium on Superconductivity ISS'09, Tsukuba, Japan, November 2-4 (2009)
- Larbaestier, D.C., *Are there routes to a round wire multifilament high Tc conductor?*, European Conf. on Applied Superconductivity (EUCAS), Dresden, Germany, September 14-18 (2009)
- Larbaestier, D.C., *High Temperature Superconductors for High Field Use*, Int. School on Fusion Reactor Technology, Erice, Italy, September 9-16 (2009)
- Larbaestier, D.C., *Potential for Superconducting Magnets above 30T*, Hanau, Germany, February 10 (2009)
- Larbaestier, D.C., *Prospects for the development of round wire multifilament forms of HTS conductors*, Int. Symposium on Superconductivity ISS'09, Tsukuba, Japan, November 2-4 (2009)
- Larbaestier, D.C., *Superconductors for Accelerator Use: What's next and how close is the ideal conductor?*, Fermilab Colloquium, Batavia, Chicago, February 24 (2009)
- Larbaestier, D.C., *Superconductors for Future High Field Use: Why not multifilamentary YBCO - or something even better?*, British Cryogenics Council Lecture, Oxford University, Oxford, UK, March 30 (2009)
- Larbaestier, D.C., *Superconductors for future high field use: why not multifilamentary YBCO - or something even better?*, CEA Cadarache, March 23 (2009)
- Lee, J.; Reitze, D.H.; Kono, J.; McGill, S.A.; Belyanin, A. and Solomon, G., *Ultrafast Relaxation Dynamics of a High Density Electron-Hole Plasma in High Magnetic Fields*, American Physical Society March Meeting, Pittsburgh, PA, March 16-20 (2009)
- Lee, J.; Wang, X.; Reitze, D.H.; McGill, S.A.; Jho, Y.D.; Kono, J.; Belyanin, A.A. and Solomon, G., *Ultrafast Absorption and Emission Dynamics of Dense Quantized Magneto-plasmas in High Magnetic Fields*, Southeastern Ultrafast Conf., CREOL-Townes Laser Center, University of Central Florida, Orlando, FL, January 15-16 (2009)
- Lee, J.E.; Kellie, J.F.; Tran, J.C.; Vellaichamy, A.; Ahlf D.; Tipton, J.D.; Marshall, A.G. and Kelleher, N.L., *A high throughput format for Top Down Proteomics using GELFrEE coupled to nanocapillary-LTQ FT ICR MS at >12 Tesla*, 57th ASMS Conf. on Mass Spectrometry & Allied Topics, Philadelphia, PA, May 31 - June 4 (2009)

- Lee, P.J.; Polyanskii, A.A. and Larbalestier, D.C., *Microstructural Heat Treatment and Cabling Study of High-Performance Superconducting Nb₃Sn for High Field Accelerator Magnets*, 2009 CEC-ICMC, Tucson, AZ, June 29-July 2 (2009)
- Lespinats, S.; Meyer-Baese, A.M.; He, H.; Marshall, A.G.; Conrad, C.A. and Emmett, M.R., *Novel Insights into the Lipidome of Glioblastoma Cells Based on a Combined PLSR and DD-HDS Computational Analysis*, SPIE Evolutionary and Bio-Inspired Computation: Theory and Applications, Orlando, FL, April 13-17 (2009)
- Levy, J., *Etch-a-Sketch Nanoelectronics*, Texas Section American Association of Physics Teachers, San Marcos, TX, October 23 (2009)
- Levy, J., *Oxide Nanoelectronics On Demand*, University of Basel, Basel, Switzerland, April 3 (2009)
- Levy, J., *Oxide Nanoelectronics On Demand*, University of Tokyo, Tokyo, Japan, July 3 (2009)
- Levy, J., *Oxide Nanoelectronics: A New Platform for Quantum Information Technology*, KITP, Santa Barbara, CA, December 9 (2009) [[read online](#)]
- Levy, J., *Oxide Nanoelectronics*, Argonne National Laboratory, Chicago, IL, November 25 (2009)
- Levy, J., *Oxide Nanoelectronics*, Duke University, Raleigh, NC, November 9 (2009)
- Levy, J., *Oxide Nanoelectronics*, Florida State University, Tallahassee, FL, November 4 (2009)
- Levy, J., *Oxide Nanoelectronics*, IBM T.J. Watson Research Center, Ossining, NY, October 29 (2009)
- Levy, J., *Oxide Nanoelectronics*, SUNY at Buffalo, Buffalo, NY, September 16 (2009)
- Levy, J., *Oxide Nanoelectronics*, UC Davis, Davis, CA, December 4 (2009)
- Levy, J., *Oxide Nanoelectronics*, University of Minnesota, Minneapolis, MN, November 17 (2009)
- Levy, J., *Oxide Nanoelectronics*, University of North Carolina, Chapel Hill, NC, November 8 (2009)
- Levy, J., *Oxide Nanoelectronics*, University of South Florida, Tampa, FL, November 12 (2009)
- Levy, J., *Oxide Nanoelectronics*, University of Wisconsin, Madison, WI, November 11 (2009)
- Levy, J., *Oxide Nanoelectronics*, Workshop on Oxide Electronics 16, Tarragona, Spain, October 3 (2009)
- Levy, J., *Oxide Nanoelectronics*, University of Pennsylvania, Philadelphia, PA, November 3 (2009)
- Levy, J., *Possible observation of integer and fractional quantum hall states in an interfacial oxide nanostructure*, University of Minnesota, Minneapolis, MN, November 18 (2009)
- Levy, J., *Quantum Computing with Oxides and Semiconductors*, Rutgers University, New Brunswick, NJ, April 22 (2009)
- Li, P.; Abramov, D.; Larbalestier, D.; Xie, Y.; Chen, Y. and Selvamanickam, V., *In Field Low Temperature Laser Scanning Microscopy Study of IBAD-MOCVD YBCO Coated Conductors*, Material Research Society 2009 Spring Meeting, San Francisco, CA, April 13-17 (2009)
- Liu, J.; Datta, S.; Bolin, E.; Lawrence, J.; Beedle, C.C.; Hendrickson, D.N. and Hill, S., *Anisotropic exchange in a tetranuclear Co complex*, Florida Inorganic Mini-Symposium, Gainesville, FL, October 2-3 (2009)
- LoSchiavo, M.; Jiang, J.; Trociewitz, U.P.; Larbalestier, D.C. and Hellstrom, E.E., *Impact of Insulation Material on Jc of BSCCO 2212*, 2009 CEC-ICMC, June 29-July 2 (2009)
- Lu, J.; Downey, S.T.; Goddard, R.; Han, K.; Kalu, P.N.; Toplosky, V.J.; Walsh, R.P. and Xin, Y., *Comparison and Understanding of Cryogenic Properties of 316LN and MP35N*, Cryogenic Engineering and Int. Cryogenic Materials Conf., Tucson, AZ, June 28-July 02 (2009)
- Lu, J.; Han, K. and Walsh, R.P., *Low Temperature Physical Properties of a High Mn Austenitic Steel JK2LB*, Cryogenic Engineering and Int. Cryogenic Materials Conf., Tucson, AZ, June 28-July 02 (2009)
- Lumata, L.L., *Spin Dynamics of Density Wave and Frustrated Spin Systems Probed by NMR*, Department of Physics, University of California-Riverside, Riverside, CA, January 21 (2009) [[read online](#)]
- Lumata, L.L.; Choi, K.-Y.; Besara, T.; Hoch, M.J.R.; Zhou, H.D.; Brooks, J.S.; Kuhns, P.L.; Reyes, A.P.; Dalal, N.S. and Wiebe, C.R., *^{69,71}Ga NMR probe of the spin dynamics in the rare-earth kagome Pr₃Ga₃SiO₁₄*, American Physical Society March Meeting, Pittsburgh, PA, March 16-20 (2009) [[read online](#)]
- Lumata, L.L.; Hoch, M.J.R.; Moulton, W.G.; Zhou, H.D.; Brooks, J.S.; Reyes, A.P.; Kuhns, P.L. and Wiebe, C.R., *⁹³Nb NMR investigation of the multiferroic system Ba₃NbFe₃Si₂O₁₄*, American Physical Society March Meeting, Pittsburgh, PA, March 16-20 (2009) [[read online](#)]
- Luo, H.; Lin, Y.; Wang, H.; Baily, S.A.; Lee, H.; Hawley, M.E.; McCleskey, T.; Burrell, A.K.; Bauer, E.; Civalo, L. and Jia, Q., *Amorphous Silica Nanoparticles Embedded in Epitaxial SrTiO₃ and CoFe₂O₄ Matrices*, Materials Research Society Spring Meeting 2009, San Francisco, CA, April 16 (2009)
- Maierov, B.; Baily, S.A.; Kohama, Y.; Hiramatsu, H.; Balakirev, F.F.; Hirano, M. and Hosono, H., *Pseudo-isotropic Upper Critical Field in Cobalt-Doped SrFe₂As₂ Epitaxial Films*, EUCAS 2009, Dresden, Germany, September 14 (2009)
- Maierov, B.; Baily, S.A.; Zhou, H.; Durrell, J.H.; Foltyn, S.R.; Civalo, L. and Jaime, M., *Effect of Strong Disorder and Splay on the Melting Line of Tunable BaZrO₃-doped YBa₂Cu₃O₇ up 50 T*, Materials Research Society Spring Meeting 2009, San Francisco, CA, April 15 (2009)
- Maierov, B.; Zhou, H.; Baily, S.A.; Kenisson, J.A.; Dowden, P.C.; Foltyn, S.R.; Holesinger, T.H. and Civalo, L., *Influence of additions and growth dynamics in YBCO in vortex pinning properties*, EUCAS 2009, Dresden, Germany, September 16 (2009)
- Maierov, B.A.; Baily, S.A.; Civalo, L.; Foltyn, S.R.; Zhou, H.; Kennison, J.A.; Dowden, P.C.; Holesinger, T.G. and Ugurlu, O., *Synergetic combination of different types of defects to optimize pinning landscape using BaZrO₃-doped YBa₂Cu₃O₇*, Material Division Review, Los Alamos, NM, May 5 (2009)
- Mallick, S.; Salters, V.J.M. and Perfit, M.R., *Small length scale heterogeneity beneath the East Pacific Rise*, American Geophysical Union, San Francisco, CA, December (2009); Published in *Eos Trans. AGU, Fall Meet. Suppl.*, **90** (52), 31-07 (2009)
- Mao, Y.; Tipton, J.D.; Blakney, G.T.; Hendrickson, C. and Marshall, A.G., *Valence parity for c/z ions from ECD of Peptides: Effect of enzyme digestion, H. atom transfer and charge state*, 57th ASMS Conf. on Mass Spectrometry & Allied Topics, Philadelphia, PA, May 31 - June 4 (2009)

- Mao, Y.; Tipton, J.D.; Blakney, G.T.; Hendrickson, C. and Marshall, A.G., *Valence parity for c/z ions from ECD of Peptides: Effect of enzyme digestion, H. atom transfer and charge state*, 7th North American FT MS Conf., Key West, FL, April 19-23 (2009)
- Mapolelo, M.M.; Rodgers, R.P. and Marshall, A.G., *Isolation and Characterization of Naphthenic Acids in Crude Oils by Electrospray Ionization FT-ICR Mass Spectrometry*, 57th Amer. Soc. Mass Spectrom. Annual Conf. on Mass Spectrometry & Allied Topics, Philadelphia, PA, May 31-June 5 (2009)
- Mapolelo, M.M.; Rodgers, R.P. and Marshall, A.G., *Isolation and Characterization of Naphthenic Acids in Crude Oils by Electrospray Ionization FT-ICR Mass Spectrometry*, 7th N. Amer. Fourier Transform Mass Spectrometry Conf., Key West, FL, April 19-22 (2009)
- Mapolelo, M.M.; Rodgers, R.P.; Yen, A.T.; Debord, J.; Asomaning, S. and Marshall, A.G., *Characterization of Naphthenic Acids in Naphthenates by Electrospray Ionization FT-ICR Mass Spectrometry*, 10th Int. Conf. on Petroleum Phase Behaviour and Fouling, Rio de Janeiro, Brazil, June 14-18 (2009)
- Markiewicz, W.D.; Weijers, H.J.; Noyes, P.D.; Trociewitz, U.P.; Pickard, K.P.; Sheppard, W.R.; Jaroszynski, J.J.; Xu, A.; Larbalestier, D.C. and Hazelton, D.W., *33.8 Tesla with a YBa₂Cu₃O_{7-x} Superconducting Test Coil*, Cryogenic Engineering and Int. Cryogenic Materials Conf., Tucson, AZ, June 28-July 02 (2009)
- Marshall, A.G., *Gas-Phase Biomolecular Ions: What Can They Tell Us?*, 2009 Gordon Research Conf. on Biological Molecules in the Gas Phase, Tilton, NH, July 5-10 (2009)
- Marshall, A.G., *Prospects and Needs for Higher Mass Spectral Resolution*, 2009 Taiwan Society of Mass Spectrometry Meeting, Taipei, Taiwan, June 25-26 (2009)
- Marshall, A.G., *Prospects and Needs for Higher Mass Spectral Resolving Power*, Michael Bowers 70th Birthday Symp., Santa Barbara, CA, June 18-20 (2009)
- Marshall, A.G., *Ultrahigh Mass Resolution and Mass Accuracy: What's Possible, What's Not, and What It's Good For*, The Role of Accurate Mass Proteomics in Chromatin/Cancer Biology Symp., Northwestern U., Evanston, IL, March 9 (2009)
- Marshall, A.G.; Blakney, G.T.; Emmett, M.R.; Hendrickson, C.L.; Rodgers, R.P.; Tipton, J.D. and Xian, F., *Ultrahigh Mass Resolution and Mass Accuracy: What's Possible, What's Not, and What It's Good For*, Symp. on Accurate Mass Measurement: State of the Art, Uses, and Limitations, Pittcon 2009, Chicago, IL, March 8-14 (2009)
- Marshall, A.G.; Kaiser, N.K.; Hendrickson, C.L.; Dunk, P.W. and Kroto, H.W., *Cluster Ion Source Designed for 9.4 T FT-ICR Identification of Products of Mass-Selected Ion-Molecule Reactions*, 57th Amer. Soc. Mass Spectrom. Annual Conf. on Mass Spectrometry & Allied Topics, Philadelphia, PA, May 31-June 5 (2009)
- Marshall, A.G.; Xian, F.; Hendrickson, C.L. and Blakney, G.T., *Broadband Absorption-Mode FT-ICR MS: 30% Enhancement in Resolving Power*, 7th N. Amer. Fourier Transform Mass Spectrometry Conf., Key West, FL, April 19-22 (2009)
- Mccamey, D.R.; Morley, G.M.; Paik, S.-Y.; Lee, S.-Y.; Brunel, L.C.; van Tol, J. and Boehme, C., *A new electrical readout mechanism for Si:P qubits*, American Physical Society March Meeting, Pittsburgh, PA, March 16-20 (2009)
- McGill, S.A.; Tokumoto, T.; Cherian, J. and Gebre, T., *Ultrafast User Optics at the NHMFL in Tallahassee*, Southeastern Ultrafast Conf., CREOL-Townes Laser Center, University of Central Florida, Orlando, FL, January 15-16 (2009)
- McKenna, A.M.; Purcell, J.M.; Rodgers, R.P.; Rahimi, P. and Marshall, A.G., *Nonpolar Speciation of Athabasca Bitumen by Atmospheric Pressure Photoionization Fourier Transform Ion Cyclotron Resonance Mass Spectrometry*, Symp. on Alternative Hydrocarbons: Tar Sand, Oil Shale and Heavy Oil: Production, Processing and Chemistry, 237th Amer. Chem. Soc. Nat'l. Mtg., Salt Lake City, UT, March 22-26 (2009)
- McKenna, A.M.; Rodgers, R.P. and Marshall, A.G., *A Unified Theory of Asphaltene Structure*, 57th Amer. Soc. Mass Spectrom. Annual Conf. on Mass Spectrometry & Allied Topics, Philadelphia, PA, May 31-June 5 (2009)
- McKenna, A.M.; Rodgers, R.P. and Marshall, A.G., *Compositional Analysis of Heavy Conventional Crude Oils: The Definition of Asphaltenes and Maltenes by High-Resolution FT-ICR Mass Spectrometry*, Symp. on Methods and Techniques in Analytical Characterization for Fuel Science, 237th Amer. Chem. Soc. Nat'l. Mtg., Salt Lake City, UT, March 22-26 (2009)
- McKenna, A.M.; Rodgers, R.P.; Purcell, J.M. and Marshall, A.G., *Identification, Characterization, and Quantitation of Vanadyl Porphyrins in Heavy Crude Oil by FT-ICR Mass Spectrometry*, 10th Int. Conf. on Petroleum Phase Behaviour and Fouling, Rio de Janeiro, Brazil, June 14-18 (2009)
- Menjoge, A.R.; Huang, Q.; Eic, M.; Kaliaguine, S. and Vasenkov, S., *Sorbate Diffusion on Different Length Scales in SBA-15 Porous Solids by Pulsed Field Gradient NMR and Zero Length Column Techniques*, American Institute of Chemical Engineers (AIChE) Annual Meeting, Nashville, TN, November 8-13 (2009)
- Merdignac, I.; Purcell, J.M.; Rodgers, R.P.; Marshall, A.G.; Thierry, G. and Guibard, I., *Characterization of Residual Asphaltene during Hydroconversion Processes Determined by APPI FT-ICR Mass Spectrometry*, 10th Int. Conf. on Petroleum Phase Behaviour and Fouling, Rio de Janeiro, Brazil, June 14-18 (2009)
- Misra, S. and Froelich, P.N., *Isotopic Evidence for Large Scale Temporal Changes in the Cenozoic Marine Lithium Cycle*, America Geophysical Union, Fall Meeting, San Francisco, CA, December 14-18 (2009); Published in *EOS Trans AGU*, **90** (54), 21-02 (2009)
- Miura, M.; Baily, S.A.; Maiorov, B.; Civale, L.; Willis, J.O.; Izumi, T.; Tanabe, K. and Shiohara, Y., *Irreversibility line up to 65 T in nanoparticle dispersed Y_{1-x}Gd_xBa₂Cu₃O_y coated conductors derived from the TFA-MOD process*, Int. Symposium on Superconductivity 2009, Tsukuba, Japan, November 3 (2009)
- Miura, M.; Baily, S.A.; Maiorov, B.; Civale, L.; Willis, J.O.; Izumi, T.; Tanabe, K. and Shiohara, Y., *Irreversibility Line up to 65 T in Nanoparticles Dispersed TFA-MOD YGdBCO Coated Conductors*, Int. Workshop On Coated Conductors For Applications, Barcelona, Spain, November 23 (2009)
- Moraes, S.; Khadka, R.P.; Gapud, A.A.; Reyes, A.P.; Lumata, L.L.; Thompson, J.R. and Christen, D.K., *Moving flux quanta, driven by high density currents in low-impurity samples of V₅Si, LuNi₂B₂C, and NbSe₂: Ordered flow and core-size effects*, American Physical Society March Meeting, Pittsburgh, PA, March 16-20 (2009) [[read online](#)]
- Murray, D.T. and Cross, T.A., *Solid State NMR of Membrane Proteins: Towards complex structural and functional information for bacterial ABC class transporters*, 53rd Annual Biophysical Society Meeting, Boston, MA, February (2009)

- Murray, D.T. and Cross, T.A., *Solid State NMR Studies of Structure- Activity Relationships in Large Membrane Proteins*, 50th ENC Conference, Pacific Grove, CA, March (2009)
- Ni, D.; Qin, H.; Sharma, M. and Cross, T.A., *Making Membrane Protein LspA Samples and its uniformly aligned full length investigated by Solid State NMR*, 53rd Annual Biophysical Society Meeting, Boston, MA, February (2009)
- Ni, D.; Qin, H.; Sharma, M. and Cross, T.A., *Purification Refolding and Structural Investigations of the Membrane Protein, Lipoprotein Signa Peptidase (LspA) by Solid State NMR*, 50th ENC Conference, Pacific Grove, GA, March (2009)
- Nikolaev, E.N.; Vladimirov, G.; Boldin, I.; Hendrickson, C.L.; Blakney, G.T. and Marshall, A.G., *Limits of FT-ICR MS resolution and dynamic range from Supercomputer Modeling of Ion Cloud Motion in an ICR Cell*, 57th Amer. Soc. Mass Spectrom. Annual Conf. on Mass Spectrometry & Allied Topics, Philadelphia, PA, May 31 - June 5 (2009)
- Nikolaev, E.N.; Vladimirov, G.; Boldin, I.; Herren, R.; Hendrickson, C.L.; Blakney, G.T. and Marshall, A.G., *Dynamic Range and Resolution of FT-ICR Mass Spectrometry from Supercomputer Simulations*, 7th N. Amer. Fourier Transform Mass Spectrometry Conf., Key West, FL, April 19-22 (2009)
- Nilsson, C.L.; He, H.; Emmett, M.R.; Marshall, A.G.; Moskal, J.R.; Kroes, R.A.; Colman, H. and Conrad, C.A., *Cancer Stem Cells: A Combined Glycolipidomic and Glycotranscriptomic Approach*, Symp. on Accurate Mass Measurement: State of the Art, Uses, and Limitations, Pittcon 2009, Chicago, IL, March 8-14 (2009)
- Nilsson, C.L.; Huan, H.; Emmett, M.R.; Marshall, A.G.; Moskal, J.R.; Kroes, R.A.; Dillon, R.; Devakkumar, A. and Conrad, C.A., *It's a Sweet World: Glycomics Analysis and Cellular Communication in the Extra- and Intracellular Space*, 57th Amer. Soc. Mass Spectrom. Annual Conf. on Mass Spectrometry & Allied Topics, Philadelphia, PA, May 31-June 5 (2009)
- Noyes, P., *Magnets and Superconductivity at the NHMFL*, NWF Section of Institute of Electrical and Electronic Engineers, Ft. Walton, FL, March 24 (2009)
- Ong, N.P., *Field Induced Phase Transition at Dirac Point of Graphene*, American Physical Society March Meeting, Pittsburgh, PA, March (2009)
- Ozarowski, A., *High-Field EPR and Magnetic Studies on Polynuclear Transition Metal Complexes*, European Conference on Molecular Magnetism, Wroclaw (Poland), October 4-7 (2009); Published in [Conference Abstracts](#), 29 (2009)
- Padmanabhan, M.; Gokmen, T. and Shayegan, M., *Valley polarization and the polarization mass of composite fermions around $\nu = 3/2$* , American Physical Society March Meeting, Pittsburgh, PA, March 17 (2009) [[read online](#)]
- Park, J.G.; Lin, C.p.; Smithyman, J.; Cooke, A.; Li, S.; Liang, R.; Zhang, C.; Wang, B.; Kismarahardja, A. and Brooks, J.S., *Effects of surfactant to the physical properties of single-walled carbon nanotube buckypaper*, American Physical Society March Meeting (poster session), Pittsburgh, PA, March 18 (2009)
- Paster, J.; Ninios K.; Chan, H.B. and Balicas, L., *Micromechanical devices for magnetization measurements at high magnetic fields and low temperatures*, American Physical Society March Meeting, Pittsburgh, PA, March 16-20 (2009)
- Plocinski, P.; Kiran, M.; Nguyen, H.; Dziedzic, R.; Cross, T.A.; Brzostek, A.; Guzek, M.; Dziadek, J.; Madiraju, M. and Rajagopalan, M., *Initial Characterization of Rv0008c and Rv0011c, two potential cell division regulatory proteins of Mycobacterium tuberculosis*, Texas TB Meeting, TX, February (2009)
- Polyanskii, A.A.; Lee, P.J.; Starch, W.; Larbalestier, D.C.; Barzi, E.; Turrioni, D. and Zlobin, A.V., *Magneto-Optical and Microstructural Studies of Reacted Rutherford Cables Fabricated From RRP-IT and PIT Nb₃Sn Strands*, 2009 CEC-ICMC, Tucson, AZ, June 29-July 2 (2009)
- Popovic, D., *Glassy charge dynamics and magnetotransport in lightly doped La₂CuO₄*, colloquium, Institute of Physics, Belgrade, Serbia, July (2009)
- Popovic, D., *Glassy charge dynamics and magnetotransport in lightly doped La₂CuO₄*, invited talk, Emergence of Inhomogeneous Phases in Strongly Correlated Electron Systems (Glassy '09), conference, Paris, France, July (2009)
- Popovic, D., *Nonequilibrium dynamics in Coulomb glasses near the metal-insulator transition*, 3 lectures, 2009 Boulder School: Nonequilibrium Statistical Mechanics: Fundamental Problems and Applications, Boulder, CO, July (2009) [[read online](#)]
- Pramudya, Y.; Pankov, S.; Manousakis, E. and Dobrosavljevic, V., *Nearly Frozen Coulomb Liquid*, American Physical Society March Meeting, Pittsburgh, PA, March 16-20 (2009) [[read online](#)]
- Qian, C.; Masad, I.; Grant, S. and Gor'kov, P., *Broad Range Tunable Birdcage Coil for Rat Head MRI at 21.1 Tesla*, ENC, Asilomar, Pacific Grove, CA, March 29-April 3 (2009)
- Raicevic, I.; Popovic, D.; Panagopoulos, C. and Sasagawa, T., *Novel positive magnetoresistance in lightly doped La₂CuO₄*, American Physical Society March Meeting, Pittsburgh, PA, March (2009)
- Redler, G.; Koo, C.; Datta, S.; Lampropoulos, C.; Stamatatos, T.C.; Christou, G. and Hill, S., *Magnetization barrier reduction in Mn₁₂ single-molecule magnets*, American Physical Society March Meeting, Pittsburgh, PA, March (2009) [[read online](#)]
- Reyes, A.P., *Superconductivity and Levitation in the World's Biggest Magnets*, (invited Symposium), Philippine Normal University, Manila, Philippines, August 6 (2009)
- Reyes, A.P., *Superconductivity and Levitation in the World's Biggest Magnets*, Lecture Series (invited), West Visayas State University, Iloilo City, Philippines, July 30 (2009)
- Rikvold, P.A., *Dynamics of Magnetization Switching in Models of Magnetic Nanoparticles and Ultrathin Films*, 10th Boulder School for Condensed Matter and Materials Physics, Boulder, CO, July 21 (2009)
- Rikvold, P.A., *Hysteresis and Dynamic Phase Transition in Kinetic Ising Models and Ultrathin Magnetic Films*, 10th Boulder School for Condensed Matter and Materials Physics, Boulder, CO, July 22 (2009)
- Rikvold, P.A., *Macro-biophysics: Statistical Physicists Look at Evolution and Ecology*, 10th Boulder School for Condensed Matter and Materials Physics, July 23 (2009)
- Rikvold, P.A., *Metastability and Finite-size Effects in Magnetization Switching*, 10th Boulder School for Condensed Matter and Materials Physics, Boulder, CO, July 20 (2009)

- Rikvold, P.A., *Statistical Mechanics in Evolution and Ecology*, Int. Symposium on Applications of Statistical Physics, The Norwegian Academy of Science and Letters, Oslo, Norway, January 29-30 (2009)
- Rodgers, R.P.; Juyal, P.; McKenna, A.M. and Marshall, A.G., *Detailed Heteroatom Speciation in Petroleum by High Resolution FT-ICR MS*, Symp. on Methods and Techniques in Analytical Characterization for Fuel Science, 237th Amer. Chem. Soc. Nat'l. Mtg., Salt Lake City, UT, March 22-26 (2009)
- Rodgers, R.P.; McKenna, A.M. and Marshall, A.G., *Analytical Convergence in a Unified Theory of Asphaltene Structure*, 10th Int. Conf. on Petroleum Phase Behaviour and Fouling, Rio de Janeiro, Brazil, June 14-18 (2009)
- Rodgers, R.P.; McKenna, A.M.; Mapolelo, M.M. and Marshall, A.G., *Resolution, Mass Accuracy, and 30,000 Peaks: Detailed Petroleum Analysis by FT-ICR Mass Spectrometry*, 7th N. Amer. Fourier Transform Mass Spectrometry Conf., Key West, FL, April 19-22 (2009)
- Rodgers, R.P.; Purcell, J.M.; McKenna, A.M. and Marshall, A.G., *Identification, Characterization and Quantitation of Vanadyl Porphyrins in Heavy Crude Oil by FT-ICR Mass Spectrometry*, 57th Amer. Soc. Mass Spectrom. Annual Conf. on Mass Spectrometry & Allied Topics, Philadelphia, PA, May 31-June 5 (2009)
- Salters, V.J.M.; Bizimis, M.; Sachi-Kocher, A.; Taylor, R.; Savov, I.P. and Stern, C.R., *Subduction related fluids fractionate Nb/Ta*, American Geophysical Union, San Francisco, CA, December (2009); Published in *Eos Trans. AGU, Fall Meet. Suppl.*, **90** (52), 51-1757 (0)
- Salters, V.J.M.; Mallick, S. and Sachi-Kocher, A., *Source Variations Along the EPR Identify Melt Flow and Influence Segmentation*, American Geophysical Union, Joint Assembly, Toronto, Canada, May (2009); Published in *Eos Trans. AGU, Jt. Assem. Suppl.*, **90** (22) (0)
- Sandler, N.; Vernek, E.; Dias da Silva, L.G.G.V.; Ingersent, K. and Ulloa, S.E., *Zeeman vs resonance splitting effects in a double quantum dot system*, American Physical Society March Meeting, Pittsburgh, PA, March 16-20 (2009)
- Sankaran, S.; Mao, C.; Seok, E.; Shim, D.; Cao, C.; Han, R.; Arenas, D.J.; Tanner, D.B.; Hill, S.; Hung, C.-M. and O, K. K., *Towards Terahertz Operation of CMOS*, IEEE Int. Solid-State Circuits Conf., San Francisco, CA, February (2009)
- Schepkin, V.D.; Levenson, C.W.; Figueiroa, S.M.; Brey, W.W.; Gor'kov, P.L. and Shetty, K.K., *Sodium and Proton Diffusion MRI of Rodent Glioma Therapy at 21 T*, Oral Presentation, ISMRM-2009, Annual Meeting and Exhibition, Honolulu, HI, April 18-24 (2009); Published in *Proceedings, 17th Annual Meeting, ISMRM - 2009*, 612 (2009) [[read online](#)]
- Schwartz, J., *Advanced Materials for a Sustainable Energy Future: How Advanced Oxides Are Helping to Create the 21st Century Smart Grid*, Virginia Commonwealth University, Richmond, VA, February (2009)
- Schwartz, J., *What Limits the Performance & Lifetime of Superconducting Materials & Systems?*, North Carolina State University, Raleigh, NC, April (2009)
- Schwartz, J., *What Limits the Performance & Lifetime of Superconducting Materials & Systems?*, Tulane University, New Orleans, LA, March (2009)
- Schwartz, J., *What Limits the Performance & Lifetime of Superconducting Materials & Systems?*, University of Delaware, Newark, DE, March (2009)
- Schwartz, J., *What Limits the Performance & Lifetime of Superconducting Materials & Systems?*, University of Twente, Enschede, Netherlands, June (2009)
- Sharma, M.; Qin, H.; Li, C.; Busath, D.D. and Cross, T.A., *M2 Proton Channel from Influenza A Virus Studied by Solid State NMR Spectroscopy*, 50th ENC Conference, Pacific Grove, CA, March (2009)
- Sharma, M.; Qin, H.; Peterson, E.; Larson, C.; Caywood, W.; Rawlings, R.; Busath, D. and Cross, T.A., *Structural and Functional Studies of M2 Proton Channel from Influenza A Virus*, 53rd Annual Biophysical Society Meeting, Boston, MA, February (2009)
- Shayegan, M.; Gokmen, T. and Padmanabhan, M., *Dependence of Effective Mass on Spin and Valley Degrees of Freedom*, American Physical Society March Meeting, Pittsburgh, PA, March 18 (2009) [[read online](#)]
- Shen, T.; Hellstrom, E.E.; Jiang, J.; Larbalestier, D.C.; Schwartz, J. and Trociewitz, U.P., *Strong Influence of Overdoping in Enhancing the Critical Current Density of Bi₂Sr₂CaCu₂O_x Round Wires*, 2009 CEC-ICMC, Tucson, AZ, June 29-July 2 (2009)
- Shi, X.; Jaroszynski, J.; Popovic, D.; Panagopoulos, C.; Logvenov, G.; Bollinger, A. and Bozovic, I., *Glassy effects in magnetotransport in La_{1.97}Sr_{0.03}CuO₄ thin films*, American Physical Society March Meeting, Pittsburgh, PA, March (2009)
- Shirai, N.; Humayun, M. and Irving, A.J., *The bulk composition of coarse-grained meteorites from laser ablation analysis of their fusion crusts*, Lunar & Planetary Science Conf. XL, The Woodlands, TX, March 23-27 (2009) [[read online](#)]
- Shirai, N.; Humayun, M. and Richter, K., *Analysis of moderately siderophile elements in angrites: implications for core formation of the angrite parent body*, Lunar & Planetary Science Conf. XL, The Woodlands, TX, March 23-27 (2009) [[read online](#)]
- Smirnov, D., *Magnetic field assisted sub-THz quantum cascade lasers*, EP2DS/MSS, Kobe, Japan, July 19-24 (2009)
- Smirnov, D., *Magnetic-field-assisted THz quantum cascade laser (invited)*, 10th Int. Conf. on Intersubband Transitions in Quantum Wells, Montreal, Canada, September 6-11 (2009) [[read online](#)]
- Song, H.; Davidson, M.W. and Schwartz, J., *Visualization of normal zone propagation in YBaCuO coated conductor using magneto-optical imaging*, 2009 Cryogenic Engineering and Int. Cryogenic Materials Conf., Tucson, AZ, June 28-July 2 (2009)
- Song, H.H. and Schwartz, J., *Direct observation of normal zone behavior in YBaCuO coated conductors during quenching using magneto-optical imaging*, the 21st Int. Conf. on Magnet Technology (MT-21), Hefei, China, October 18-23 (2009)
- Stegen, Z.; Riggs, S.C.; Kemper, J.B.; Jo, Y.-J.; Balicas, L.; Boebinger, G.S.; Balakirev, F.F.; Migliori, A.; Chen, H.; Liu, R.H. and Chen, X.H., *Log-T upturn in resistivity of lightly-doped oxypnictide superconductor in an intense magnetic field*, American Physical Society March Meeting, Pittsburgh, PA, March 16-20 (2009)
- Suh, S.; Clark, W.G.; Brown, S.E.; Samulon, E.C.; Fisher, I.R.; Batista, C.D.; Reyes, A.P.; Kuhns, P.; Lumata, L.L. and Brooks, J.S., *^{135,137}Ba NMR study of condensed phase and critical behavior in S=1 spin dimer system Ba₃Mn₂O₈*, American Physical Society March Meeting, Pittsburgh, PA, March 16-20 (2009) [[read online](#)]
- Suslov, A., *2DEG effect on vibration of piezoelectric plates*, American Physical Society March Meeting, Pittsburgh, PA, March 16-20 (2009); Published in *Bulletin of the American Physical Society*, **54** (1) (2009)

- Suzuki, Y.; Betts, J.B. and Migliori, A., *Second harmonic technique for thermal conductivity measurement in a pulsed magnetic field*, American Physical Society March Meeting, Pittsburgh, PA, March 10-20 (2009)
- Telser, J., *A Journey Across the First Row of the Transition Metals With High-frequency/field Electron Paramagnetic Resonance (HFEP)*, Chemistry Department, University of Kansas, Lawrence, KS, February 27 (2009)
- Telser, J., *A Journey Across the First Row of the Transition Metals With High-frequency/field Electron Paramagnetic Resonance (HFEP)*, Chemistry Department, University of Oregon, Eugene, OR, April 10 (2009)
- Telser, J., *Coordination Chemistry of Paramagnetic "Scorpionate" Complexes: A Case Study for High-Frequency and -Field Electron Paramagnetic Resonance (HFEP)*, Chemistry Department, Indiana University, Bloomington, IN, April 17 (2009)
- Terletska, H. and Dobrosavljevic, V., *Fingerprints of intrinsic phase separation in magnetically-doped 2DEG*, American Physical Society March Meeting, Pittsburgh, PA, March 16-20 (2009) [[read online](#)]
- Tibbetts, N.J.; Bizimis, M.; Keshav, S.; Longo, M.; Salters, V.J.M. and McCammon, C.A., *The Oxygen Fugacity Structure of the Sub-Oceanic Lithosphere and Upper Mantle as Recorded by Spinel Peridotite and Garnet Clinopyroxene Xenoliths from O'ahu, Hawai'i*, American Geophysical Union Fall Meeting, San Francisco, CA, December 14-18 (2009); Published in *EOS Transactions of the American Geophysical Union, Fall Meeting V33C-2052*, **90** (52) (2009) [[read online](#)]
- Tipton, J.D.; Carter, J.; Mathias, J.D.; Emmett, M.R.; Fanucci, G.E. and Marshall, A.G., *High Performance Nano-LC ESI FT-ICR MS to Verify Desulfide Connectivity and Spin-Labeled XàC GM2AP Mutants*, 2nd Moffitt Symp. on Mass Spectrometry (MSMS), Tampa, FL, February 11-12 (2009)
- Tipton, J.D.; Kaiser, N.K.; Blakney, G.T.; Hendrickson, C.L. and Marshall, A.G., *Tandem Mass Spectrometry for Top Down Proteomics: Comparison Between Resonant and Beam-Type Collisionally Activated Dissociation*, 7th North American FT MS Conf., Key West, FL, April 19-23 (2009)
- Tipton, J.D.; Kellie, J.F.; Thomas, P.M.; Ahlf, D.; Hendrickson, C.L.; Kelleher, N.L. and Marshall, A.G., *Top-down proteomics with a 14.5 T FT-ICR mass spectrometer: Secondary ion collection in an external octopole ion trap*, 57th ASMS Conf. on Mass Spectrometry & Allied Topics, Philadelphia, PA, May 31-June 4 (2009)
- Tipton, J.D.; Nilsson, C.L.; Emmett, M.R.; He, H.; Nair, S.S.; Marshall, A.G.; Sheng, X. and Conrad, C.A., *The Glioblastoma Exosomal Proteome: Modulation by Wild-type p53*, HUP02009 World Congress, Toronto, ON Canada, September 28-30 (2009); Published in *Clinical Proteomics*, **5** (Sup 1), 64 (2009) [[read online](#)]
- Tipton, J.D.; Tran, J.C.; Lee, J.E.; Kellie, J.F.; Catherman, A.D.; Kelleher, N.L. and Marshall, A.G., *Top Down Proteomics at High Magnetic Field*, Atlanta / Athens Mass Spectrometry Discussion Group Summer Symposium, Atlanta, GA, October 6-7 (2009)
- Tokumoto, T.; Cherian, J.; Gebre, T.; deRosa, R.; Sahanggamu, P.; Ghosh, S.; Zhou, H.; Wiebe, C.R.; and McGill, S.A., *Time-resolved Optical Study of Charge-ordered Manganites*, American Physical Society March Meeting, Pittsburgh, PA, March 16-20 (2009) [[read online](#)]
- Toplosky, V.J.; Han, K. and Walsh, R.P., *Fatigue properties of modified 316LN Stainless Steel Metal at 4 K for High Field Cable-in-Conduit Applications*, Cryogenic Engineering and Int. Cryogenic Materials Conf., Tucson AZ, June 28-July 2 (2009)
- Tran, H. and Bonesteel, N.E., *Valence Bond Monte Carlo Study of Random Singlet Phase Formation*, American Physical Society March Meeting, Pittsburgh, PA, March 16-20 (2009) [[read online](#)]
- Tremaine, D.M.; Froelich, P.N.; Kowalczyk, A. and Kilgore, B., *Speleochem Paleoclimatology and Modern Proxies: Calcite Farming in a Continuously Monitored Cave*, American Geophysical Union, Fall Meeting, San Francisco, CA, December 14-18 (2009); Published in *EOS Trans AGU*, **90** (54), 41-1513 (2009)
- Trociewitz, U.P.; Markiewicz, W.D.; Jiang, J.; Myers, D.; Hellstrom, E.E.; Jaroszynski, J.; Noyes, P.; Viouchkov, Y.; Xu, A. and Larbalestier, D.C., *High Field Magnets with HTS Conductors*, Magnet Technology Conf. (MT-21), Hefei, China, October 18-23 (2009); Published in *IEEE Trans. Appl. Supercond.* (0)
- Truong, M.; Fu, R. and Cross, T.A., *Chemical Shift Anisotropy Tensor Measurements using High Resolution Heteronuclear Correlation Spectroscopy in Solid State NMR*, 50th ENC Conference, Pacific Grove, CA, March (2009)
- Truong, M.L.; Fu, R. and Cross, T.A., *Ion Interactions of Gramicidin A using Multidimensional Proton Solid State NMR*, 53rd Annual Biophysical Society Meeting, Boston, MA, February (2009)
- Tsujii, H.; Kim, Y.H.; Takano, Y.; Murphy, T.P.; He, Z.; Ueda, H. and Ueda, Y., *Field-Induced Quantum Phase Transitions in the Spin-1/2 Antiferromagnetic Ising-Chain Compound BaCo₂V₂O₈*, Meeting of the Physical Society of Japan, Kumamoto, Japan, September 25-28 (2009)
- Tung, L.-C.; Wu, X.-G.; Pfeiffer, L.N.; West, K.W. and Wang, Y.-J., *Unusual broadening of cyclotron resonance linewidth at high magnetic field in the two dimensional electron system*, EP2DS, Kobe, Japan, July 19-24 (2009)
- Vafek, O. (Oskar), *Dynamical Conductivity of graphene (at the neutrality point)*, American Physical Society March Meeting, Pittsburgh, PA, March 16 (2009) [[read online](#)]
- Vafek, O. (Oskar), *Graphene flatland*, Goucher College colloquium (invited talk), Towson, MD, April 16 (2009)
- Vafek, O. (Oskar), *Interaction and disorder effects in graphene*, Johns Hopkins U. condensed matter physics seminar (invited talk), Baltimore, MD, April 15 (2009)
- Vafek, O. (Oskar), *Interaction and disorder effects in graphene*, Kavli Institute for Theoretical Physics (invited talk), Low Dimensional Electron Systems workshop, Santa Barbara, CA, May 19 (2009)
- Vafek, O. (Oskar), *Interaction and disorder effects in graphene*, Princeton University condensed matter seminar (invited talk), Princeton, NJ, April 13 (2009)
- Vafek, O. (Oskar), *Interaction and disorder effects in single and double layer graphene*, Graphene conf. at Centro de Ciencias de Benasque Pedro Pascual (invited talk), Benasque, Spain, July 29 (2009) [[read online](#)]
- Vafek, O. (Oskar), *Interaction and disorder effects on graphene*, Stanford University condensed matter seminar (invited talk), Stanford, CA, May 22 (2009)

- Vafek, O. (Oskar), *Quantum oscillations in the mixed state of d-wave superconductors*, Aspen Center for Physics (invited blackboard talk) (Workshop on quantum vortices and fluctuations in superconductors and superfluids), Aspen, CO, July 8-9 (2009)
- Vafek, O. (Oskar), *Quasiparticles in the vortex state of d-wave superconductors*, 17th Conf. of Slovak Physicists (invited plenary talk), Bratislava, Slovakia, September 19 (2009) [[read online](#)]
- Vafek, O. (Oskar), *Quasiparticles in the vortex state of d-wave superconductors*, Max Planck Institute for Solid State Research seminar (invited talk), Stuttgart, Germany, September 22 (2009) [[read online](#)]
- Valeja, S.G.; Emmett, M.R. and Marshall, A.G., *Reduced Back-Exchange by Modified RPLC Mobile Phase Separation of Proteolytic Peptides for MS Analysis of H/D Exchange of Solution-Phase Proteins*, 57th Amer. Soc. Mass Spectrom. Annual Conf. on Mass Spectrometry & Allied Topics, Philadelphia, PA, May 31-June 5 (2009)
- Valeja, S.G.; Emmett, M.R. and Marshall, A.G., *Reduced Back-Exchange by Modified RPLC Mobile Phase Separation of Proteolytic Peptides for MS Analysis of H/D Exchange of Solution-Phase Proteins*, 7th North American FT MS Conf., Key West, FL, April 19-23 (2009)
- Van Niekirk, D.; Humayun, M. and Keil, K., *In situ determination of siderophile trace elements in EL3 meteorites*, Lunar & Planetary Science Conf. XL, The Woodlands, TX, March 23-27 (2009) [[read online](#)]
- Van Sciver, S.W., *Measurements of drag on an oscillating sphere in helium II*, Workshop on Topics in Quantum Turbulence, Trieste, Italy, March 16-20 (2009)
- Van Sciver, S.W., *Particle Image Velocimetry Investigations of Turbulence in Superfluid Helium*, Seminar presented at the Mechanical Engineering Department, University of Calgary, Alberta, Canada, May 26 (2009)
- Van Sciver, S.W., *Particle Image Velocimetry Measurements of Forced Flow He II*, 2009 Cryogenic Engineering Conf., Tucson, AZ, July 2 (2009)
- Van Sciver, S.W., *Thermal and mechanical properties of cryogenic insulations for aerospace vehicles*, The 1st symposium of the Florida Center for Advanced Aero-Propulsion (FCAAP), Orlando, FL, August (2009)
- van Tol, J. and Zvanut, M.E., *Pulsed ENDOR at 240 GHz of nitrogen centers in 4H-SiC: Towards a detailed description of the wavefunction*, American Physical Society March Meeting, Pittsburgh, PA, March 16-20 (2009)
- van Tol, J., *High Field and Frequency Electron Nuclear Double Resonance and Dynamic Nuclear Polarization*, University of Virginia, Nuclear Physics Seminar, Charlottesville, VA, April 14 (2009)
- van Tol, J., *High Field EPR and ENDOR of Qubits*, Institute for Terahertz Science and Technology Seminar, University of California at Santa Barbara, Santa Barbara, CA, March 5 (2009)
- VanLandingham, J.W.; Rich, N.J.; Winnard, K.; Levenson, C.W.; Figueiroa, S.M.; Schepkin, V.D.; Seth, R.; Overton, J.M. and Stein, D.G., *Combinatorial treatment with progesterone and thyrotropin releasing hormone improves outcomes after traumatic brain injury*, Experimental Biology, New Orleans, LA, April 18-22 (2009); Published in [Proceedings EB - 2009 \(D326 614.9\)](#) (0)
- Velasquez, J.E.; McKenna, A.M.; Rodgers, R.P. and Marshall, A.G., *The Petroleum: A Mass Spectral Database of Petroleum Composition*, 57th Amer. Soc. Mass Spectrom. Annual Conf. on Mass Spectrometry & Allied Topics, Philadelphia, PA, May 31-June 5 (2009)
- Wang, J.; Nittler, L.R.; Humayun, M. and Burnett, D.S., *Chromium fluence measurements in Genesis samples using a Nano-SIMS*, 72nd Annual Meeting of the Meteoritical Society, Nancy, France, July 13-18 (2009); Published in [Meteoritics & Planetary Sciences](#), **44**, 213 (2009)
- Wang, X.; Tipton, J.D.; Emmett, M.R. and Marshall, A.G., *Verification of Selenomethionine Incorporation by Top-Down and Bottom-Up Mass Spectrometry*, 57th ASMS Conf. on Mass Spectrometry & Allied Topics, Philadelphia, PA, May 31-June 4 (2009)
- Wang, Xu.; Tipton, J.D.; Emmett, M.R. and Marshall, A.G., *Verification of Selenomethionine Incorporation by Top-Down and Bottom-Up Mass Spectrometry*, 7th North American FT MS Conf., Key West, FL, April 19-23 (2009)
- Wang, Y. (Yang), *Geographic variations in diets and environments of late Cenozoic herbivores in China: Evidence from stable isotopes*, A Workshop and Symposium toward the Establishment of a Continent-Wide Stratigraphic and Chronologic Framework, Beijing, China, June 8-14 (2009)
- Weijers, H., *High-temperature superconductors in high-field magnets*, Ph.D. Defense presentation, University of Twente, The Netherlands, June 24 (2009) [[read online](#)]
- Weijers, H.W., *HTS magnets: ready for applications or not?*, Magnet Technology MT-21, special session, panel discussion, Hefei, China, October 18-23 (2009) [[read online](#)]
- Weijers, H.W.; Lu, J.; Trociewitz, U.P.; Walsh, R.P. and Markiewicz, W.D., *Electro-mechanical characterization of HTS and LTS conductors at the NHMFL*, Superconductivity Research Center, Korea Electrotechnology Research Institute (KERI), Changwon, Korea, July 15 (2009) [[read online](#)]
- Weijers, H.W.; Trociewitz, U.P.; Markiewicz, W.D. and Larbalestier, D.C., *Technology for High Field Magnets with YBCO Conductors*, US-Japan Workshop, NHMFL, Tallahassee, FL, December 14 (2009) [[read online](#)]
- Weijers, H.W.; Trociewitz, U.P.; Markiewicz, W.D.; Jaroszynski, J.; Noyes, P.; Viouchkov, Y. and Larbalestier, D.C., *Thin Large-Diameter Layer-Wound YBCO Coils at High Hoop Stress*, Int. Symposium on Superconductivity (ISS-2009), Tsukuba, Japan, November 2-4 (2009) [[read online](#)]
- Weijers, H.W.; Walsh, R.P. and McRea, D., *Activities in USA (NHMFL)*, VAMAS/IEC TC-90 meeting, Tsukuba, Japan, November 5 (2009) [[read online](#)]
- Weijers, H.W.; Walsh, R.P. and McRea, D., *Curve fitting of stress-strain curve and RRT of Ag/Bi-2212 round wires*, IEC TC90 WorkGroup 5-Andong meeting, Andong, Korea, July 13-14 (2009) [[read online](#)]
- Wiebe, C.; Zhou, H.; Janik, J.; Balicas, L.; Jo, Y.-J.; Qiu, Y.; Copley, J. and Gardner, J., *Dynamic spin ice: Pr₂Sn₂O₇*, American Physical Society March Meeting, Pittsburgh, PA, March 16-20 (2009)
- Xian, F.; Hendrickson, C.L.; Blakney, G.T.; Beu, S.C. and Marshall, A.G., *Improved Broadband Phase Correction of Complex FT-ICR Mass Spectra: Baseline Roll and Apodization*, 57th Amer. Soc. Mass Spectrom. Annual Conf. on Mass Spectrometry & Allied Topics, Philadelphia, PA, May 31 - June 5 (2009)

- Xian, F.; Hendrickson, C.L.; Blakney, G.T.; Beu, S.C. and Marshall, A.G., *Improved Broadband Phase Correction of Complex FT-ICR Mass Spectra: Baseline Roll and Apodization*, 7th N. Amer. Fourier Transform Mass Spectrometry Conf., Key West, FL, April 19-22 (2009)
- Xu, X.; Angst, M.; Brinzari, T.; Hermann, R.; Musfeldt, J.L.; Christianson, A.; Mandrus, D.; Sales, B.; McGill, S.A.; Kim, J.-W. and Islam, Z., *Charge order, dynamics, and magneto-structural transition in multiferroic LuFe_2O_4* , American Physical Society March Meeting, Pittsburgh, PA, March 16-20 (2009)
- Yamamoto, A.; Jaroszynski, J.; Jiang, J.; Gurevich, A.; Larbalestier, D.C.; Jin R.; Sefat, A.; McGuire, M.A.; Sales, B.C.; Christen, D.K. and Mandrus D., *Small anisotropy, weak thermal fluctuations, and high field superconductivity in Co-doped 122 pnictide $\text{Ba}(\text{Fe}_{1-x}\text{Co}_x)_2\text{As}_2$* , Int. Workshop on the Search for New Superconductors, Shonan, Japan, May 15 (2009)
- Yamamoto, A.; Polyanskii, A.; Abraimov, D.; Gurevich, A.; Larbalestier, D.; Zhuang, C.G.; Xi, X.X. and Putti, M., *Understanding the microscopic intergranular current transport in MgB_2* , 14th US-Japan Workshop on Advanced Superconductors, Tallahassee, FL, December 15 (2009)
- Yamamoto, A.; Polyanskii, A.A.; Jiang, J.; Kametani, F.; Putti, M.; Tarantini, C.; Hunte, F.; Jaroszynski, J.; Hellstrom, E.E.; Guverich, A. and Larbalestier, D.C., *Inter- and intra-granular current properties of iron pnictide superconductors*, American Physical Society March Meeting, Pittsburgh, PA, March 20 (2009)
- Yen, A.T.; Mapolelo, M.M.; Rodgers, R.P.; Juyal, P.; Allenson, S.; Wang, J.; Creek, J. and Marshall, A.G., *Compositional Variations between Precipitated and Real View Deposition Cell Asphaltenes and Effect of Inhibitors on Deposition by Electro Spray Ionization FT-ICR Mass Spectrometry*, 10th Int. Conf. on Petroleum Phase Behaviour and Fouling, Rio de Janeiro, Brazil, June 14-18 (2009)
- Yi, M.; Cross, T.A. and Zhou, H.-X., *Conformational heterogeneity of the M2 proton channel: a model for channel activation*, Biophysical Society 53rd Annual Meeting, Boston, MA, February (2009) [[read online](#)]
- Yuan, H.; Baily, S.A.; Singleton, J.; Balakirev, F.; Chen, G.F.; Luo, J.L. and Wang, N.L., *Isotropic low-temperature upper critical field in $(\text{Ba},\text{K})\text{Fe}_2\text{As}_2$* , American Physical Society March Meeting, Pittsburgh, PA, March 20 (2009)
- Zapf, V.S., *Bose-Einstein Condensation in a Quantum Magnet*, Max Planck Institute for Chemical Physics of Solids, Dresden, Germany, November 12 (2009)
- Zapf, V.S., *Dilatometry*, NHMFL Users Summer School, Tallahassee, FL, June 21-28 (2009)
- Zapf, V.S., *Organo-metallic magnetoelectrics*, Materials Capability Review, Los Alamos National Laboratory, Los Alamos, NM, May (2009)
- Zapf, V.S.; Kenzelmann, M.; Wolff-Fabris, F. and Chen, Y., *Magnetically-induced electric polarization in an organic quantum magnet*, MEIPC 6 (Multiferroics conference), Santa Barbara, CA, January (2009)
- Zapf, V.S.; Kenzelmann, M.; Wolff-Fabris, F.; Balakirev, F. and Chen, Y., *Organo-metallics: a new frontier for magnetoelectric interactions*, Calorimetry Conf. 2009, Santa Fe, NM, June 28-July 2 (2009)
- Zhai, Y. and Bird, M.D., *Iron Magnetic Shielding of the Series Connected Hybrid Magnet*, 21th Biennial Int. Conf. on Magnet Technology (MT-21), Hefei, China, October 18-23 (2009)
- Zhang, F.; Robinette, S.L.; Bruschweiler-Li, L. and Bruschweiler, R., *Metabolic Mixture Analysis by Heteronuclear NMR*, 50th Experimental Nuclear Magnetic Resonance Conf., Asilomar, CA, March 29-April 3 (2009)
- Zhang, H.-M.; Emmett, M.R.; Marshall, A.G.; Yu, X.; Greig, M.; Lunney, E.; Frantom, P.A. and Blanchard, J.S., *Data Automation and Fast RPLC Applied to Hydrogen/Deuterium Exchange FT-ICR Mass Spectrometry to Reduce Back Exchange*, Lab Automation 2009, Palm Springs, CA, January 24-28 (2009)
- Zhang, H.-M.; Frantom, P.A.; Blanchard, J.S.; Emmett, M.R. and Marshall, A.G., *Solution-Phase H/D Exchange FT-ICR Mass Spectrometry to Elucidate an Allosteric Pathway in the Regulation of α -Isopropylmalate Synthase from *Mycobacterium tuberculosis**, 23rd Protein Soc. Symp., Boston, MA, July 25-29 (2009)
- Zhang, H.-M.; Mcloughlin, S.M.; He, H.; Nilsson, C.L.; Emmett, M.R. and Marshall, A.G., *Conformational and Functional Effect of Posttranslational Modifications on sRAGE Protein by Solution-Phase H/D Exchange FT-ICR Mass Spectrometry*, 57th Amer. Soc. Mass Spectrom. Annual Conf. on Mass Spectrometry & Allied Topics, Philadelphia, PA, May 31-June 5 (2009)
- Zhang, H.-M.; Mcloughlin, S.M.; He, H.; Nilsson, C.L.; Emmett, M.R. and Marshall, A.G., *H/D Exchange FT-ICR Mass Spectrometry to Reveal Conformational and Functional Effects of Posttranslational Modifications on sRAGE Protein*, 7th N. Amer. Fourier Transform Mass Spectrometry Conf., Key West, FL, April 19-22 (2009)
- Zhang, H.-M.; Yu, X.; Greig, M.; Lunney, E.; Emmett, M.R. and Marshall, A.G., *Drug Resistance Mechanism of KIT Kinase in Gastrointestinal Stromal Tumor Patients Revealed by Hydrogen/Deuterium Exchange FT-ICR MS*, 2nd Moffitt Symp. on Mass Spectrometry (MSMS), Tampa, FL, February 11-12 (2009)
- Zhang, Z.; Huzarska, M.; Tipton, J.D.; Emmett, M.R.; Marshall, A.G. and Polfer, N., *Structural Study of Non-Enzymatic Glycation in Human Serum Albumin*, 2nd Moffitt Symp. on Mass Spectrometry (MSMS), Tampa, FL, February 11-12 (2009)
- Zhang, Z.; Huzarska, M.; Tipton, J.D.; Emmett, M.R.; Marshall, A.G. and Polfer, N., *Structural study of non-enzymatic glycation in human serum albumin*, 57th ASMS Conf. on Mass Spectrometry & Allied Topics, Philadelphia, PA, May 31-June 4 (2009)

BOOKS, CHAPTERS, REVIEWS & OTHER ONE-TIME PUBLICATIONS

- Abou Hamad, I.; Robb, D.E. and Rikvold, P.A., "First-order Reversal Curve Analysis of Kinetic Monte Carlo Simulations of First- and Second-order Phase Transitions", *Computer Simulation Studies in Condensed-Matter Physics XIX*, edited by D. P. Landau, S. P. Lewis, and H.-B. Schüttler (Springer-Verlag, Berlin Heidelberg, 2009), 89-93, 2009.
- Fish, K.N. and Davidson, M.W., "Fluorescent Biomarkers in Neurons", *Encyclopedia of Neuroscience*, **4**, 261-271, 2009.
- Gaffney, B.J., "EPR of Mononuclear Non-Heme Iron Proteins", *High Resolution EPR: Applications to Metalloenzymes and Metals in Medicine Series: Biological Magnetic Resonance*, **28**, 233-268, 2009.
- Haupt, T.A. and Smith, J.C., "Conditioned taste aversion induced by exposure to high magnetic fields", *Conditioned Taste Aversion: Behavioral and Neural Processes*, 422-444, 2009.

Snyder, D.A. and Bruschiweiler, R., "Multi-dimensional correlation spectroscopy by covariance NMR", *Encyclopedia of Magnetic Resonance* (editors D.M. Grant and R.K. Harris), Wiley, 2009.

Weijers, H. (Huub), "High-temperature superconductors in high-field magnets", *Printed by Ipskamp printers, Enschede*, 196 pages, 2009.

INTERNET DISSEMINATIONS

Drichko, I.L.; Smirnov, I.Yu.; Suslov, A.V.; Mironov, O.A. and Leadley, D.R., *Magnetoresistance in Dilute p-Si/SiGe in Parallel and Tilted Magnetic Fields*, <http://arxiv.org/abs/0910.2833>, (October 15 2009)

Fanelli, V.R.; Lawrence, J.M.; Wang, C.H.; Christianson, A.D.; Bauer, E.D.; McClellan, K.J.; Goremychkin, E.A. and Osborn, R., *Inelastic neutron scattering studies of the intermediate valence compound CePd₃*, <http://arxiv.org/abs/0908.4378>, (2009)

He, H.; Nilsson, C.L.; Emmett, M.R.; Ji, Y.; Marshall, A.G.; Kroes, R.A.; Moskal, J.R.; Colman, H.; Lang, F.F. and Conrad, C.A., *Polar lipid remodeling and increased sulfatide expression are associated with the glioma therapeutic candidates, wild type p53 elevation and the topoisomerase-1 inhibitor, Irinotecan*, <http://www.springerlink.com/content/v44u781381484638/fulltext.pdf>, (June 26 2009)

PATENTS & OTHER PRODUCTS

Emmett, M.R.; Kazacic, S.; Marshall, A.G. and Greig, M.J., "Analytical Method for Protein Mapping Using Hydrogen/Deuterium Exchange", (2009)

AWARDS, HONORS & SERVICE

Abernathy, C. (Cammy), American Physical Society Fellow (2009)

Bou-Assaf, G.M. (George), American Heart Association Predoctoral Fellowship (2009)

Cappendijk, S. (Susanne), FSU First Year Assistant Professor Award (2009)

Collar, K. (Kristen), Lannutti Award for Undergraduate Research (FSU Department of Physics) (2009)

Dobrosavljevic, V. (Vladimir), Marko V. Jaric Prize for Outstanding Scientific Achievement in Physics (2009)

Dufty, J.W. (James), American Physical Society Fellow (2009)

Gurevich, A. (Alexander), American Physical Society "Outstanding Referee" Award (2009)

Hannahs, S.T. (Scott), American Physical Society Fellow (2009)

Hayes, S.E. (Sophia), Regitze R. Vold Memorial Prize (2009)

He, H. (Huan), 2009 Dorothy and Russell Johnsen Dissertation Award, FSU Department of Chemistry and Biochemistry (2009)

He, H. (Huan), HUPO (Human Proteome Organization) Young Investigator Award in the Stem Cell Proteome Biology category (2009)

Hughey, C. (Christine), Undergraduate Analytical Research Program from the Society of Analytical Chemists of Pittsburgh (2009)

Ingersent, K. (Kevin), American Physical Society Fellow (2009)

Jewell, M. (Matthew), ITER Monaco Postdoctoral Fellow (2009)

Kalu, P. (Peter), Fulbright Scholar (2009)

Lounsbury, A. (Amanda), Fulbright Scholarship (2009)

Marshall, A.G. (Alan), 2009 Award for Outstanding Achievements in Mass Spectrometry (2009)

Marshall, A.G. (Alan), 2009 Eni Award: New Frontiers in Hydrocarbons (2009)

Marshall, A.G. (Alan), Eastern Analytical Symposium Award for Outstanding Achievements in Mass Spectrometry (2009)

Marshall, A.G. (Alan), Fellow of the American Chemical Society, Inaugural Group (2009)

Maslov, D. (Dmitri), American Physical Society Fellow (2009)

McKenna, A. (Amy), American Chemical Society Petroleum Chemistry Student Award (2009)

Meisel, M.W. (Mark), American Physical Society Fellow (2009)

Pawlicki, A. (Alison), Lynn Shannon Proctor Fellowship, FSU Department of Physics (2009)

Schlottmann, P. (Pedro), American Physical Society "Outstanding Referee" Award (2009)

Sebastian, S. (Suchitra Esther), Royal Society University Research Fellowship (2009-2014)

Tanner, D. (David), 2009-2011 University of Florida Research Foundation Professorship (2009-2011)

Zhang, H.-M. (Hui-Min), FSU Department of Molecular Biophysics - 14th Annual Kasha Award (2009)

PH.D. DISSERTATIONS

Adams-Hughes, M. (Michelle), "Microstructure and Texture Inhomogeneity in Friction Stir Processed and Annealed Aluminum Alloy AA5052", Florida A&M University, Mechanical Engineering, advisor: Kalu, P. (Peter) (2009)

Bhupathi, P. (Pradeep), "Construction of an Ultralow Temperature Cryostat and Transverse Acoustic Spectroscopy in Superfluid Helium-3 in Compressed Aerogels", University of Florida, Physics, advisor: Lee, Y. (Yoonseok) (2009)

Biasatti, D. (Dana), "Paleoenvironments and Paleoecologies of Cenozoic Mammals from Western China Based on Stable Carbon and Oxygen Isotopes", Florida State University, Geological Sciences, advisor: Wang, Y. (Yang) (2009)

Bishop, N.C., "Interacting Two Dimensional Systems with a Discrete Degree of Freedom", Princeton University, Electrical Engineering, advisor: Shayegan, M. (Mansour) (2009)

- Cho, K.** (Kyuil), "Upper Critical Field Study in the Organic Superconductor beta" $-(\text{ET})_2\text{SF}_5\text{CH}_2\text{CF}_2\text{SO}_3$: Possibility of FFLO state", Clark University, Physics, advisor: Agosta, C.C. (Chuck) (2009)
- Chumillas, M.V.** (Marta Viciano), "Phenol-pyrazole Ligands in the Design of Manganese(III) Compounds: Synthesis, Structural Characterization and Study of the Magnetic Properties", Leiden University, the Netherlands, Chemistry, advisors: de Jongh, L. Jos and Reedijk, J. (Jan) (2009)
- Cornell, H.** (Heather), "Optimization of Contrast Agents for High Magnetic Fields", University of Florida, Biomedical Engineering, advisors: Walter, G. (Glenn) and Edison, A.S. (Art) (2009)
- Datta, S.** (Saiti), "Studying the Effects of Interplay Between Anisotropy and Exchange in Molecular Nanomagnets", University of Florida, Physics, advisor: Hill, S. (Stephen) (2009)
- Gaboardi, M.** (Mabry), "Geochemical Analyses of Paleoenvironments and Processes: Peking Man to Stardust", Florida State University, Geological Sciences, advisors: Humayun, M. (Munir) and Wang, Y. (Yang) (2009)
- Harrington, S.** (Sophie), "Nano-structuring of $\text{YBa}_2\text{Cu}_3\text{O}_{7-x}$ for Increased Critical Current", University of Cambridge, Materials Science & Metallurgy, advisor: Driscoll, J. (Judith) (2009)
- He, H.** (Huan), "Electrospray Ionization Fourier Transform Ion Cyclotron Resonance Mass Spectrometry in Biological Applications: Lipids and Proteins", Florida State University, Chemistry & Biochemistry, advisor: Marshall, A.G. (Alan) (2009)
- Lee, J.** (Jinho), "Dense Quantized Magneto-Plasmas in High Magnetic Fields Probed by Ultrafast Lasers", University of Florida, Physics, advisor: Reitze, D. (David) (2009)
- Li, X.** (Xin), "Tracing the Flow of Phosphorus, Carbon and Nitrogen in Aquatic Ecosystems", Florida State University, Geological Sciences, advisor: Wang, Y. (Yang) (2009)
- McKenna, A.** (Amy), "Detailed Characterization of Heavy Crude Oils and Asphaltenes by Ultrahigh Resolution Fourier Transform Ion Cyclotron Resonance Mass Spectrometry", Florida State University, Chemistry & Biochemistry, advisor: Marshall, A. (Alan) (2009)
- McNeill, S.A.** (Seth), "Optimization of Hardware and Software for Solid State Nuclear Magnetic Resonance at High Magnetic Fields", University of Florida, Electrical and Computer Engineering, advisors: Arroyo, A. (Antonio), UF, Electrical and Computer Engineering; Long, J. (Joanna), Biochemistry and Molecular Biology (2009)
- Misra, R.** (Rajiv), "Experiments on Electron Interaction and Localization in Disordered Magnetic Thin Films", University of Florida, Physics, advisor: Hebard, A. (Art) (2009)
- Pointer-Keenan, C.** (Caroline), "Monitoring Dynamical and Structural Changes at the Lipid-Water Interface Through Chemical Shift Analysis: A XE-129 NMR Study", University of Florida, Chemistry, advisor: Bowers, C.R. (Clifford Russell) (2009)
- Purcell, K.** (Kenneth), "High Pressure and High Magnetic Field Skin Depth Studies of the Heavy Fermion CeIn_3 ", Florida State University, Physics, advisors: Schlottmann, P. (Pedro) and Tozer, S. (Stan) (2009)
- Raicevic, I.** (Ivana), "Charge Glassiness and Magnetotransport in Lightly Doped Cuprates", Florida State University, Physics, advisors: Popovic, D. (Dragana) and Dobrosavljevic, V. (Vladimir) (2009)
- Sanders, M.**, "Development and Application of High-Field, High-Gradient Pulsed Field Gradient NMR for Studies of Diffusion Behavior of Lipids in Model Membranes", University of Florida, Chemical Engineering, advisor: Vasenkov, S. (Sergey) (2009)
- Singh, S.** (Gunetta), "Size Effects in Phase Separated Manganite Nanostructures", University of Florida, Physics, advisor: Hebard, A. (Art) (2009)
- Velos, J.** (Janice), "Mechanism of Activation at Atomic Resolution of the Signaling Protein NtrC", Brandeis University, Biochemistry, advisor: Kern, D. (Dorothee) (2009)
- Weijers, H.** (Huub), "High-temperature Superconductors in High-field Magnets", University of Twente, Low Temperature Division, The Netherlands, advisor: ten Kate, prof. dr. ir. H.H.J. (2009)
- Yoo, C.-D.** (Chi-Deuk), "Phenomenology of Supersolids", University of Florida, Physics, advisor: Dorsey, A. (Alan) (2009)
- Yuan, Z.** (Zhouquan), "Quantum Transport in Spatially-Modulated Two-Dimensional Electron and Hole Systems", Rice University, Physics and Astronomy, advisor: Du, R. (Rui-Rui) (2009)
- Zhang, H.-M.** (Hui-Min), "Hydrogen/Deuterium Exchange Monitored by Liquid Chromatography Electrospray Ionization Fourier Transform Ion Cyclotron Resonance Mass Spectrometry-Method Optimization and Applications to the Study of Protein Conformation and Protein-Drug Interactions", Florida State University, Molecular Biophysics, advisor: Marshall, A.G. (Alan) (2009)
- Zikos, G.** (Georgios), "Braiding and Berry's Phase in Non-Abelian Quantum Hall States", Florida State University, Physics, advisor: Bonesteel, N.E. (Nicholas) (2009)
- ### MASTER THESES
- Crosswhite, M.R.** (Mark Ray), "High-Performance Liquid Chromatography Electrospray Ionization Fourier Transform Ion Cyclotron Resonance Mass Spectrometry of Citrus Extract: Structural Probing of Flavonoids", FSU, Chemistry and Biochemistry, advisor: Marshall, A. (Alan) (2009)
- Hemmati, A.** (Ali), "Drag Measurements of a Sphere in Low Temperature Helium", Florida State University, Mechanical Engineering, advisor: Van Sciver, S. (Steven) (2009)
- Kowalczk, A.** (Andrew), "High Resolution Microclimate Study of Hollow Ridge Cave: Relationships between Cave Meteorology, Air Chemistry, and Hydrology and the Impact on Speleothem Deposition", Florida State University, Oceanography, advisor: Froelich, P.N. (2009)
- Vergara, L.I.** (Luciana), "Magnetoelastic Coupling in Kagome Lattice Materials", University of Tennessee, Chemistry, advisor: Musfeldt, J.L. (Janice) (2009)
- White, J.M.** (Jessica), "Charge-spin Coupling in a Quantum Heisenberg Spin Ladder", University of Tennessee, Chemistry, advisor: Musfeldt, J.L. (Janice) (2009)
- Zhang, C.** (Chi), "Magnetotransport Studies in the 5/2 Quantum Hall Effect", Rice University, Physics and Astronomy, advisor: Du, R.-R. (Rui-Rui) (2009)

GRANTS AWARDED TO NHMFL-AFFILIATED FACULTY AT FLORIDA STATE UNIVERSITY

As reported by the FSU Office of Sponsored Research for calendar year 2009

Note: Individual investigator grants awarded to faculty is a measure of scientific productivity, similar to publications, presentations, and patents. The information below is presented in this context. Because individual awards are administered differently (by different agencies; under different terms), this information should not be aggregated.

PI: Alamo, Rufina G.

Grant Title: EH Branching Microstructure
Agency: Exxon Chemical Company
 Project Dates: 10/1/06 - 12/31/10
 Award: \$50,000.00

PI: Alamo, Rufina G.

Grant Title: FRG:GOAL: Collaborative Research: The Role of Polymer
Agency: National Science Foundation
 Project Dates: 7/15/07 - 6/30/10
 Award: \$90,000.00

PI: Bird, Mark D.

Grant Title: Series Connected Hybrid Construction Phase
Agency: National Science Foundation
 Project Dates: 8/25/06 - 8/31/11
 Award: \$2,822,295.00

PI: Boebinger, Gregory S.

Grant Title: National High Magnetic Field Laboratory Renewal Proposal
Agency: National Science Foundation
 Project Dates: 1/1/08 - 12/31/12
 Award: \$3,975,000.00

PI: Boebinger, Gregory S.

Grant Title: National High Magnetic Field Laboratory Renewal
Agency: National Science Foundation
 Project Dates: 8/3/09 - 12/31/12
 Award: \$5,000,000.00

PI: Bonesteel, Nicholas E.

Grant Title: Correlated Electrons in Reduced Dimensions
Agency: U.S. Department of Energy
 Project Dates: 6/1/97 - 1/31/11
 Award: \$70,000.00

PI: Brooks, James

Grant Title: Request for Travel Funds to Send US Students and Post Docs...
Agency: National Science Foundation
 Project Dates: 9/1/09 - 8/31/10
 Award: \$29,963.00

PI: Bruschweiler, Rafael P.

Grant Title: Functional Dynamics During Induced-Fit...
Agency: Oregon Health Sciences University
 Project Dates: 2/1/07 - 1/31/11
 Award: \$66,134.00

PI: Bruschweiler, Rafael P.

Grant Title: Covariance-Based NMR of Proteins and Complex Metabolite
Agency: National Institute of General Medical Sciences
 Project Dates: 5/1/09 - 4/30/10
 Award: \$280,953.00

PI: Bruschweiler, Rafael P.

Grant Title: Dynamics and Thermodynamics of Proteins by NMR
Agency: National Science Foundation
 Project Dates: 7/1/09 - 6/30/13
 Award: \$608,782.00

PI: Bruschweiler, Rafael P.

Grant Title: Covariance-Based NMR of Proteins and Complex
Agency: National Institute of General Medical Sciences
 Project Dates: 9/30/09 - 8/31/10
 Award: \$61,774.00

PI: Cao, Jianming

Grant Title: Ultrafast Dynamics in Ferromagnetic Metals and Nanoparticles
Agency: National Science Foundation
 Project Dates: 9/1/09 - 8/31/12
 Award: \$360,000.00

PI: Chanton, Jeffrey

Grant Title: Coupling of Continuous
Agency: University of Mississippi
 Project Dates: 7/1/06 - 7/31/10
 Award: \$88,508.00

PI: Chanton, Jeffrey

Grant Title: NASA AMES
Agency: National Aeronautics & Space Administration
 Project Dates: 2/15/08 - 2/14/11
 Award: \$40,965.00

PI: Chanton, Jeffrey

Grant Title: Controls on Hydrate Stability in Methane Depleted Sediment...
Agency: National Research Council
 Project Dates: 2/4/08 - 2/3/10
 Award: \$25,000.00

PI: Chanton, Jeffrey

Grant Title: Collaborative Research: Shifting Pathways Toward Methane...
Agency: National Science Foundation
 Project Dates: 8/1/09 - 7/31/13
 Award: \$321,586.00

PI: Chanton, Jeffrey

Grant Title: Additional Sampling Event for Manatee Springs, Phase 2
Agency: Florida Department of Health
 Project Dates: 12/22/08 - 6/30/09
 Award: \$2,996.72

PI: Chanton, Jeffrey

Grant Title: Final Report
Agency: Florida Department of Health
 Project Dates: 7/1/09 - 10/15/09
 Award: \$1,387.43

PI: Chanton, Jeffrey

Grant Title: Phase II Manatee Springs Additional Sampling Event
Agency: Florida Department of Health
 Project Dates: 8/4/09 - 11/15/09
 Award: \$4,097.63

PI: Cooper III, William T.

Grant Title: Identification of Reactive and Refractory Dissolved Organic...
Agency: CH2M Hill
 Project Dates: 5/18/09 - 12/30/09
 Award: \$34,644.00

PI: Cross, Timothy A.

Grant Title: Correlations: Structure-Dynamics-Functions in Channels
Agency: National Institute of Allergy & Infectious Diseases
 Project Dates: 3/1/05 - 2/28/11
 Award: \$320,249.00

PI: Cross, Timothy A.

Grant Title: Correlations: Structure-Dynamics-Functions in Channels
Agency: National Institute of Allergy & Infectious Diseases
 Project Dates: 3/1/05 - 2/28/11
 Award: \$35,584.00

PI: Cross, Timothy A.

Grant Title: Four Mtb Membrane Proteins: Structure and Function
Agency: National Institute of Allergy & Infectious Diseases
 Project Dates: 12/1/07 - 11/30/10
 Award: \$41,311.00

PI: Cross, Timothy A.

Grant Title: Four Mtb Membrane Proteins: Structure and Function
Agency: National Institute of Allergy & Infectious Diseases
 Project Dates: 12/1/07 - 11/30/10
 Award: \$371,406.00

PI: Cross, Timothy A.

Grant Title: M Tuberculosis Membrane Protein Pharmaceutical Targets
Agency: National Institute of Allergy & Infectious Diseases
 Project Dates: 8/20/09 - 7/31/10
 Award: \$1,765,751.00

PI: Davidson, Michael W.

Grant Title: Synthetic Fluorophore Evaluation
Agency: Invitrogen LLC
 Project Dates: 12/1/08 - 6/30/09
 Award: \$70,001.00

PI: Davidson, Michael W.

Grant Title: RF Salary Account For Project 025813
Agency: Invitrogen LLC
 Project Dates: 12/1/08 - 6/30/09
 Award: \$70,001.00

PI: Dixon, Patricia J.

Grant Title: QuarkNet
Agency: University of Notre Dame
 Project Dates: 9/1/08 - 8/31/10
 Award: \$10,750.00

PI: Dixon, Patricia J.

Grant Title: QuarkNet
Agency: University of Notre Dame
 Project Dates: 9/1/08 - 8/31/10
 Award: \$7,500.00

PI: Engel, Lloyd W.

Grant Title: Microwave/Rf Spectroscopy of 2D Solids/Stripes
Agency: U.S. Department of Energy
 Project Dates: 7/1/05 - 6/30/10
 Award: \$102,000.00

PI: Fajer, Piotr

Grant Title: Structure and Dynamics of Cardiac Troponin I
Agency: American Heart Association
 Project Dates: 7/1/09 - 6/30/11
 Award: \$165,000.00

PI: Gaffney, Betty

Grant Title: Reactive Intermediates in Lipoygenase Pathways
Agency: National Institute of General Medical Sciences
 Project Dates: 1/1/09 - 12/31/10
 Award: \$183,540.00

PI: Gaffney, Betty

Grant Title: Reactive Intermediates in Lipoygenase Pathways
Agency: National Institute of General Medical Sciences
 Project Dates: 9/30/09 - 8/31/10
 Award: \$78,340.00

PI: Gor'kov, Petr L.

Grant Title: Upgrade SS Low-E NMR Probe from 500 MHz to 600 MHz Field
Agency: Hamilton College
 Project Dates: 2/15/09 - 12/31/09
 Award: \$8,088.00

PI: Gurevich, Alexander

Grant Title: Exploring the Limits of Critical Currents in High Temperature...
Agency: UT-Battelle LLC
 Project Dates: 6/11/08 - 4/30/10
 Award: \$150,000.00

PI: Hill, Stephen Olof

Grant Title: Magnetic Resonance Investigations of Symmetries, Inter...
Agency: National Science Foundation
 Project Dates: 11/1/08 - 10/31/10
 Award: \$110,000.00

PI: Hill, Stephen Olof

Grant Title: International Collaboration in Chemistry: EPR Characteristics...
Agency: National Science Foundation
 Project Dates: 9/1/09 - 8/31/10
 Award: \$240,000.00

PI: Houpt, Thomas A.

Grant Title: Behavioral and Neural Effects of Static Magnetic Fields
Agency: National Institute on Deafness
 Project Dates: 7/19/06 - 6/30/10
 Award: \$234,779.00

PI: Humayun, Munir

Grant Title: Siderophile Elements in Chondrites and Achondrites
Agency: National Aeronautics & Space Administration
 Project Dates: 8/1/09 - 7/31/10
 Award: \$105,000.00

PI: Humayun, Munir

Grant Title: Elemental Abundances in the Solar Wind
Agency: National Aeronautics & Space Administration
 Project Dates: 2/15/09 - 2/14/12
 Award: \$91,495.00

PI: Landing, William

Grant Title: Atmospheric Deposition of Mercury and Trace Metals
Agency: University of West Florida
 Project Dates: 1/1/08 - 12/31/10
 Award: \$115,223.99

PI: Landing, William

Grant Title: GEOTRACES Atlantic Section: Aerosol and Rainfall Collect
Agency: National Science Foundation
 Project Dates: 8/15/09 - 7/31/12
 Award: \$300,475.00

PI: Landing, William

Grant Title: Florida State University Southeastern Mercury Consortium
Agency: National Oceanic and Atmospheric Administration
 Project Dates: 9/1/09 - 2/28/11
 Award: \$400,000.00

PI: Larbalestier, David C.

Grant Title: Grain Boundaries in Copper Oxide Superconductors
Agency: Air Force Research Laboratory
 Project Dates: 7/1/06 - 6/30/10
 Award: \$150,000.00

PI: Larbalestier, David C.

Grant Title: High Field Superconductor Development and Understanding
Agency: U.S. Department of Energy
 Project Dates: 4/1/07 - 3/31/10
 Award: \$610,000.00

PI: Larbalestier, David C.

Grant Title: Buffer Layer Growth and the Thickness Dependence
Agency: U.S. Department of Energy
 Project Dates: 6/30/08 - 7/1/10
 Award: \$350,000.00

PI: Larbalestier, David C.

Grant Title: Buffer Layer Growth and the Thickness Dependence
Agency: U.S. Department of Energy
 Project Dates: 6/30/08 - 7/1/10
 Award: \$1,944.63

PI: Larbalestier, David C.

Grant Title: International Workshop on the Search for New Superconductors
Agency: National Science Foundation
 Project Dates: 5/1/09 - 5/31/10
 Award: \$30,000.00

PI: Larbalestier, David C.

Grant Title: Electro-Mechanical Characterization and Understanding of...
Agency: Fermi National Accelerator Lab
 Project Dates: 9/1/09 - 9/30/12
 Award: \$590,500.00

PI: Lee, Peter J.

Grant Title: Understanding & Development of High Field SCs for Fusion
Agency: U.S. Department of Energy
 Project Dates: 7/1/06 - 6/30/10
 Award: \$90,000.00

PI: Lee, Peter J.

Grant Title: Investigation of Superconductivity in High Purity Niobium
Agency: Fermi National Accelerator Lab
 Project Dates: 7/20/06 - 9/30/10
 Award: \$100,000.00

PI: Lee, Peter J.

Grant Title: Investigation of the Microstructural Properties of High-...
Agency: Brookhaven National Lab. Assoc.
 Project Dates: 1/10/09 - 7/15/09
 Award: \$25,000.00

PI: Lee, Peter J.

Grant Title: Support of Conductor Qualification Program
Agency: ITER (Int'l Fusion Energy Org) Org.
 Project Dates: 4/1/09 - 3/31/12
 Award: \$475,001.00

PI: Markiewicz, William D.

Grant Title: MRI: Development of a 32 Tesla All Superconducting Magnet
Agency: National Science Foundation
 Project Dates: 10/1/09 - 9/30/12
 Award: \$1,999,942.00

PI: Marshall, Alan G.

Grant Title: Structural Mapping of Protein Complexes
Agency: National Institute of General Medical Sciences
 Project Dates: 8/1/06 - 7/31/10
 Award: \$304,809.00

PI: Oates, William

Grant Title: Development and Implementation of Piezoelectric Microjet
Agency: U.S. Army Research Office
 Project Dates: 5/1/08 - 12/31/10
 Award: \$75,480.00

PI: Oates, William

Grant Title: Field Coupled Mechanics and Nonlinear Control of Photo-R
Agency: Space and Naval Warfare Systems Center
 Project Dates: 9/23/09 - 9/22/10
 Award: \$142,563.00

PI: Odom, A. Leroy

Grant Title: GLY479 Geological Sciences Field Camp
Agency: FSU Foundation
 Project Dates: 5/8/09 - 6/22/09
 Award: \$8,933.01

PI: Pamidi, Sastry V.

Grant Title: Magnetic Shielding with High Temperature Superconductors

Agency: Office of Naval Research

Project Dates: 1/15/08 - 1/14/11

Award: \$100,000.00

PI: Pamidi, Sastry V.

Grant Title: Integrated Cryo-Cooled High Power Density Test Bed and...

Agency: Office of Naval Research

Project Dates: 8/1/09 - 6/30/11

Award: \$1,253,000.00

PI: Popovic, Dragana

Grant Title: Inhomogeneous Charge Dynamics in Strongly Correlated

Agency: National Science Foundation

Project Dates: 7/1/09 - 6/30/12

Award: \$345,000.00

PI: Rikvold, Per A.

Grant Title: Computational Studies of Nonequilibrium Processes

Agency: National Science Foundation

Project Dates: 9/15/08 - 8/31/10

Award: \$95,000.00

PI: Rodgers, Ryan P.

Grant Title: Examination of Crude Oils

Agency: Nalco Company

Project Dates: 4/1/09 - 3/31/11

Award: \$100,000.00

PI: Rodgers, Ryan P.

Grant Title: Asphaltene Characterization by FT-ICR Mass Spectrometry

Agency: Shell Global Solutions (US), Inc.

Project Dates: 3/1/09 - 2/28/11

Award: \$200,000.00

PI: Salters, Vincent

Grant Title: Hafnium Isotope Constraints of Normal MORB

Agency: National Science Foundation

Project Dates: 4/1/07 - 3/31/11

Award: \$64,348.00

PI: Salters, Vincent

Grant Title: Collaborative Research: Isotopic Investigation of Gakkell...

Agency: National Science Foundation

Project Dates: 9/1/09 - 8/31/12

Award: \$357,312.00

PI: Schlottmann, Pedro U.

Grant Title: Strongly Correlated Electron Systems

Agency: U.S. Department of Energy

Project Dates: 8/15/98 - 8/14/10

Award: \$55,000.00

PI: Shatruk, Mykhailo

Grant Title: Hybrid Fe (II) Spin Crossover Materials: Organic Conductors...

Agency: National Science Foundation

Project Dates: 8/1/09 - 8/31/12

Award: \$382,000.00

PI: Tozer, Stanley W.

Grant Title: Electron Interactions in Actinides and Related Systems

Agency: U.S. Department of Energy

Project Dates: 5/1/06 - 4/30/10

Award: \$250,000.00

PI: Van Sciver, Steven W.

Grant Title: Liquid Helium Fluid Dynamics Studies

Agency: U.S. Department of Energy

Project Dates: 1/1/96 - 1/31/11

Award: \$206,000.00

PI: Van Sciver, Steven W.

Grant Title: Liquid Helium Fluid Dynamics Studies

Agency: U.S. Department of Energy

Project Dates: 1/1/96 - 1/31/11

Award: \$100,000.00

PI: Van Sciver, Steven W.

Grant Title: Mechanical, Thermal, and Hydroscopic Properties of Solid...

Agency: University of Central Florida

Project Dates: 10/1/08 - 5/31/10

Award: \$15,873.00

PI: Van Sciver, Steven W.

Grant Title: Mechanical, Thermal, and Hydroscopic Properties of Solid...

Agency: University of Central Florida

Project Dates: 10/1/08 - 5/31/10

Award: \$17,627.00

PI: Van Sciver, Steven W.

Grant Title: Conduct Superfluid Helium Research in Support of...

Agency: Fermi National Accelerator Lab

Project Dates: 6/4/09 - 8/31/10

Award: \$100,000.00

PI: Walsh, Robert P.

Grant Title: ITER-NHMFL 2007 Materials Characterization Program

Agency: UT-Battelle LLC

Project Dates: 6/1/07 - 12/31/10

Award: \$2,736.00

PI: Walsh, Robert P.

Grant Title: ITER-NHMFL 2007 Materials Characterization Program

Agency: UT-Battelle LLC

Project Dates: 6/1/07 - 12/31/10

Award: \$13,986.00

PI: Wang, Yang

Grant Title: Technician Support for the Stable Isotope Laboratory

Agency: National Science Foundation

Project Dates: 4/1/09 - 3/31/11

Award: \$49,680.00

PI: Weijers, Hubertus W.

Grant Title: High-Current Conductor

Agency: Lawrence Berkeley Laboratory

Project Dates: 5/21/09 - 12/31/10

Award: \$10,000.00

PI: Weijers, Hubertus W.

Grant Title: High-Current Conductor

Agency: Lawrence Berkeley Laboratory

Project Dates: 5/21/09 - 12/31/10

Award: \$15,000.00

PI: Wiebe, Christopher R.

Grant Title: Towards New and Better High Temperatures Superconductors

Agency: Stanford University

Project Dates: 5/1/09 - 11/30/09

Award: \$53,000.00

PI: Yang, Kun

Grant Title: Unconventional Phases and Phase Transitions in Strongly...

Agency: National Science Foundation

Project Dates: 12/15/07 - 11/30/10

Award: \$85,000.00

PI: Yang, Kun

Grant Title: Design Principles for Quantum Hall States

Agency: Princeton University

Project Dates: 9/1/09 - 8/31/11

Award: \$109,468.00

PI: Zhou, Huan-Xiang

Grant Title: Theory of Protein-Protein Association

Agency: National Institute of General Medical Sciences

Project Dates: 4/1/08 - 3/31/10

Award: \$256,218.00

PI: Zhou, Huan-Xiang

Grant Title: Theory of Protein-Protein Association

Agency: National Institute of General Medical Sciences

Project Dates: 9/30/09 - 8/31/11

Award: \$245,174.00

GRANTS AWARDED TO NHMFL-AFFILIATED FACULTY AT THE UNIVERSITY OF FLORIDA

As reported by the UF Office of Sponsored Research for calendar year 2009

Note: Individual investigator grants awarded to faculty is a measure of scientific productivity, similar to publications, presentations, and patents. The information below is presented in this context. Because individual awards are administered differently (by different agencies; under different terms), this information should not be aggregated.

PI: Abernathy, C.

Grant Title: A 21st Century Approach to Electronic Device Reliability

Agency: U.S. Air Force

Project Dates: 5/15/08 - 5/14/13

Award: \$124,144.00

PI: Angerhofer, A.

Grant Title: National High Magnetic Field Laboratory- User Collaboration Grants Programs

Agency: Florida State University

Project Dates: 4/1/09 - 3/31/11

Award: \$118,688.00

PI: Angerhofer, A.

Grant Title: The Catalytic Mechanism of Oxalate Decarboxylase Studied by Advanced EPR Experiments

Agency: National Science Foundation

Project Dates: 7/1/08 - 6/30/11

Award: \$130,000.00

PI: Biswas, A.

Grant Title: The Effect of Strain on the Phase Separation and Magnetoelectric Coupling in Manganites

Agency: National Science Foundation

Project Dates: 8/1/08 - 7/31/11

Award: \$100,000.00

PI: Blackband, S.J.

Grant Title: Noninvasive Monitoring Glutathione Metabolism in Tumors

Agency: North Carolina State University

Project Dates: 2/27/08 - 1/31/10

Award: \$67,200.00

PI: Blackband, S.J.

Grant Title: A Study of Model B-Cells in Diabetes Treatment

Agency: National Institutes of Health

Project Dates: 5/15/02 - 8/31/11

Award: \$14,614.00

PI: Blackband S J

Grant Title: Integrated Nondestructive Spatial and Chemical Analysis of Lignocellulosic Materials During Pretreatment and Bioconv...

Agency: U.S. Department of Energy

Project Dates: 9/1/07 - 8/31/10

Award: \$103,746.00

PI: Douglas E.P.

Grant Title: Empirical Study on Emerging Research: The Role of Epistemological Beliefs and Cognitive Processing On Engineering Stud...

Agency: National Science Foundation

Project Dates: 8/15/09 - 7/31/12

Award: \$98,633.00

PI: Douglas, E.P.

Grant Title: Role of Chemical Bonding on Durability of Epoxy Adhesion to Mortar (Participant Support)

Agency: National Science Foundation

Project Dates: 6/1/07 - 5/31/10

Award: \$9,000.00

PI: Douglas, E.P.

Grant Title: Long-Term Performance of Epoxy Adhesive Anchor Systems

Agency: National Academy of Sciences

Project Dates: 7/10/09 - 7/9/12

Award: \$74,447.00

PI: Edison, A.S.

Grant Title: Upgrade of an 11T/40cm MRI/S System

Agency: National Institutes of Health

Project Dates: 1/16/09 - 1/15/10

Award: \$500,000.00

PI: Edison, A.S.

Grant Title: Improved NMR Technology for Natural Products and Metabolomics

Agency: National Institutes of Health

Project Dates: 8/1/09 - 6/30/13

Award: \$485,569.00

PI: Edison, A.S.

Grant Title: National High Magnetic Field Laboratory Project

Agency: Florida State University

Project Dates: 1/1/08 - 12/31/12

Award: \$614,544.00

PI: Edison, A.S.

Grant Title: Comparative Behavioral Metabolomics in Nematodes

Agency: National Institutes of Health

Project Dates: 5/1/09 - 2/28/13

Award: \$318,009.00

PI: Edison, A.S.

Grant Title: Comparative Behavioral Metabolomics in Nematodes

Agency: National Institutes of Health

Project Dates: 7/17/09 - 6/30/11

Award: \$349,634.00

PI: Edison, A.S.

Grant Title: Endogenous G-Protein Coupled Receptor Antagonists

Agency: National Institutes of Health

Project Dates: 4/1/03 - 7/31/13

Award: \$22,517.00

PI: Edison, A.S.

Grant Title: National High Magnetic Field Laboratory-Facilities Renewal Award-ARRA Supplement

Agency: Florida State University

Project Dates: 8/3/09 - 12/31/12

Award: \$200,000.00

PI: Edison, A.S.

Grant Title: National High Magnetic Field Laboratory Project

Agency: Florida State University

Project Dates: 1/1/08 - 12/31/12

Award: \$149,833.00

PI: Eyler, J.R.

Grant Title: Differentiating Oligosaccharide Isomers via Infrared Spectra of Gaseous

Agency: National Science Foundation

Project Dates: 9/1/07 - 8/31/10

Award: \$30,587.00

PI: Eyler, J.R.

Grant Title: Pire: A U.S.-Dutch Mass Spectrometry Consortium for Advanced Modeling and Biological Structure and Imaging Applications

Agency: Wayne State University

Project Dates: 10/1/07 - 9/30/10

Award: \$69,753.00

PI: Fanucci, G.E.

Grant Title: Membrane Binding Properties of the GM2 Activator Protein

Agency: National Institutes of Health

Project Dates: 5/5/06 - 4/30/11

Award: \$240,589.00

PI: Fanucci, G.E.

Grant Title: Career: Site-Directed Spin Labeling EPR Applications in Intrinsically Unstructured Proteins (Participant Support)

Agency: National Science Foundation

Project Dates: 8/1/08 - 7/31/10

Award: \$9,000.00

PI: Fanucci, G.E.

Grant Title: Career: Site-Directed Spin Labeling EPR Applications in Intrinsically Unstructured Proteins

Agency: National Science Foundation

Project Dates: 8/1/08 - 7/31/10

Award: \$109,250.00

PI: Fanucci, G.E.

Grant Title: Characterization of the Reversible Acid-Induced Activation Mechanism of Prorenin Using SDSL and EPR Spectroscopy

Agency: American Heart Association

Project Dates: 7/1/08 - 6/30/10

Award: \$21,770.00

PI: Forder, J.R.

Grant Title: UFCC for Cardiovascular Cell Therapy Research Network

Agency: National Institutes of Health

Project Dates: 1/1/07 - 12/31/11

Award: \$11,150.00

PI: Forder, J.R.

Grant Title: Cardiovascular Cell Therapy Research Network

Agency: University of Texas

Project Dates: 1/1/09 - 12/31/09

Award: \$96,371.00

PI: Forder, J.R.

Grant Title: UFCC for Cardiovascular Cell Therapy Research Network

Agency: National Institutes of Health

Project Dates: 1/1/07 - 12/31/11

Award: \$1,449.00

PI: Hebard, A.F.

Grant Title: Magnetoimpedance of Ultrathin Films and Thin-Film Interfaces

Agency: National Science Foundation

Project Dates: 9/1/07 - 8/31/10

Award: \$125,000.00

PI: Hershfield, S.P.

Grant Title: REU Site: Materials Physics at the University Of Florida (Participant Support)

Agency: National Science Foundation

Project Dates: 4/1/09 - 3/31/12

Award: \$97,725.00

PI: Ingersent, J.K.

Grant Title: Materials World Network - Collaborative Research: Decoherence, Correlations and Spin Effects in Nanostructured Materials

Agency: National Science Foundation

Project Dates: 9/1/07 - 8/31/10

Award: \$91,000.00

PI: Long, J.R.

Grant Title: Materials World Network: Liquid Precursor Formation and Crystallization at Interfaces: Fundamentals Toward Applications

Agency: National Science Foundation

Project Dates: 8/15/07 - 7/31/10

Award: \$19,320.00

PI: Luesch, H.

Grant Title: Chemistry and Biology of Largazoles

Agency: National Institutes of Health

Project Dates: 7/1/09 - 6/30/11

Award: \$311,950.00

PI: Luesch, H.

Grant Title: Activation of the Cancer Preventive NRF2-ARE Pathway By Seaweed

Agency: National Institutes of Health

Project Dates: 7/8/08 - 6/30/10

Award: \$156,541.00

PI: Luesch, H.

Grant Title: Pilot-Scale Libraries of Marine Cyanobacterial Natural Products

Agency: National Institutes of Health

Project Dates: 9/15/08 - 7/31/11

Award: \$332,299.00

PI: Mareci, T.H.

Grant Title: Selective Wirelessly-Adjustable Multiple-Frequency Probe (Swamp) Coil For MRI/S

Agency: National Institutes of Health

Project Dates: 5/1/09 - 3/31/11

Award: \$94,682.00

PI: Mareci, T.H.

Grant Title: Neuroimage Processing for Rehabilitation Research for Neuroimaging Core

Agency: U.S. Department of Veterans Affairs

Project Dates: 5/15/09 - 5/14/10

Award: \$10,000.00

PI: Mareci, T.H.

Grant Title: Identifying Structural and Functional Correlates in Children and Adults with Medically Intractable Epilepsy

Agency: UF Foundation

Project Dates: 5/1/09 - 4/30/11

Award: \$25,000.00

PI: Mareci, T.H.

Grant Title: Computational Transport Models for Convection-Enhanced CNS Delivery

Agency: National Institutes of Health

Project Dates: 7/1/08 - 7/31/13

Award: \$99,351.00

PI: Mareci, T.H.

Grant Title: A Study of Model B-Cells in Diabetes Treatment

Agency: National Institutes of Health

Project Dates: 5/15/02 - 8/31/11

Award: \$13,415.00

PI: Mareci, T.H.

Grant Title: CRCHS: Automatic Prediction of the Onset of Epilepsy via Analysis of High Angular Resolution Diffusion Weighted MRI

Agency: National Institutes of Health

Project Dates: 8/1/06 - 5/31/10

Award: \$85,274.00

PI: Maslov, D.

Grant Title: Materials World Network: Control of the Electron Nuclear Interaction in Nanoelectronic Devices

Agency: National Science Foundation

Project Dates: 8/1/09 - 7/31/13

Award: \$75,000.00

PI: Maslov, D.

Grant Title: Materials World Network: Control of the Electron Nuclear Interaction in Nanoelectronic Devices (Participant Cost)

Agency: National Science Foundation

Project Dates: 8/1/09 - 7/31/10

Award: \$10,000.00

PI: Meisel, M.W.

Grant Title: Magnetism of Molecule-Based Thin Films, Nanoparticles and Frustrated Systems

Agency: National Science Foundation

Project Dates: 8/15/07 - 7/31/10

Award: \$110,000.00

PI: Meisel, M.W.

Grant Title: Development of a Cryogenic Probe Suitable for Neutron Scattering Studies of Photoinduced Magnetism in Novel Materials

Agency: UT-Battelle

Project Dates: 8/14/09 - 9/15/09

Award: \$3,209.00

PI: Merz, K.M.

Grant Title: Enhancement and Deployment of the Quantum Mechanical X-Ray Refinement Model (Phase I & II)

Agency: Quantumbio

Project Dates: 6/1/08 - 11/30/08

Award: \$44,327.00

PI: Merz, K.M.

Grant Title: Mettaloenzyme Structure/ Function

Agency: National Institutes of Health

Project Dates: 2/1/07 - 1/31/11

Award: \$213,433.00

PI: Merz, K.M.

Grant Title: Quantum Chemical Evaluation of NMR Chemical Shifts In Proteins

Agency: National Science Foundation

Project Dates: 8/15/05 - 7/31/10

Award: \$165,328.00

PI: Merz, K.M.

Grant Title: Mettaloenzyme Structure/ Function

Agency: National Institutes of Health

Project Dates: 2/1/07 - 1/31/11

Award: \$23,714.00

PI: Merz, K.M.

Grant Title: The Bioinorganic Chemistry of Nickel: The UREASES and NIKR

Agency: National Institutes of Health

Project Dates: 9/30/09 - 2/28/10

Award: \$75,000.00

PI: Merz, K.M.

Grant Title: Enhancement and Development of the Quantum Mechanical X-Ray Refinement Model

Agency: Quantumbio

Project Dates: 12/1/08 - 11/30/10

Award: \$225,383.00

PI: Merz, K.M.

Grant Title: The Bioinorganic Chemistry of Nickel: The UREASES

Agency: National Institutes of Health

Project Dates: 9/1/08 - 6/30/12

Award: \$222,694.00

PI: Merz, K.M.

Grant Title: Structure and Function of Iron-Sulfur Clusters

Agency: National Institutes of Health

Project Dates: 8/1/08 - 7/31/10

Award: \$51,710.00

PI: Pearton, S.J.

Grant Title: A 21st Century Approach to Electronic Device Reliability

Agency: Us Air Force

Project Dates: 5/15/08 - 5/14/13

Award: \$125,932.00

PI: Pearton, S.J.

Grant Title: Wide Bandgap Semiconductor Nanowires for Electronic, Photonic and Sensing Devices
Agency: U.S. Army
 Project Dates: 8/1/07 - 1/31/10
 Award: \$102,000.00

PI: Pearton, S.J.

Grant Title: Development and Fabrication of Nanoelectronic Devices and Sensors
Agency: U.S. Navy
 Project Dates: 8/1/09 - 7/31/11
 Award: \$125,000.00

PI: Pearton, S.J.

Grant Title: Revenue for Alumni / Endowed Professorship
Agency: UF Foundation
 Project Dates: 9/1/05 - 6/30/10
 Award: \$20,117.00

PI: Pearton, S.J.

Grant Title: FHTCC: Technology Transfers and Further Improvement of Alangan High Electron Mobility Transistor Based Sensor Technologies
Agency: Biowell Pte
 Project Dates: 9/25/09 - 11/19/09
 Award: \$35,071.00

PI: Polfer, N.C.

Grant Title: Career: Towards an Understanding of the Underlying Chemistry in Collision-Induced Dissociation of Peptides in Mass ...
Agency: National Science Foundation
 Project Dates: 4/15/09 - 3/31/12
 Award: \$260,870.00

PI: Polfer, N.C.

Grant Title: Vibrational and Electronic Spectroscopy of Cationic Diamondoids
Agency: American Chemical Society
 Project Dates: 9/1/09 - 8/31/11
 Award: \$100,000.00

PI: Polfer, N.C.

Grant Title: Career: Towards an Understanding of the Underlying Chemistry in Collision-Induced Dissociation of Peptides in Mass ...
Agency: National Science Foundation
 Project Dates: 4/15/09 - 3/31/12
 Award: \$14,130.00

PI: Rinzler, A.G.

Grant Title: Electroactive Polymers and Electrodes Interfaces for Optimized Supercapacitors
Agency: U.S. Navy
 Project Dates: 5/1/08 - 5/31/10
 Award: \$57,688.00

PI: Rinzler, A.G.

Grant Title: Carbon Nanotube-Based Transparent Electrodes for Polymer Emittin, Electro...
Agency: NRRadiance
 Project Dates: 7/15/05 - 6/1/10
 Award: \$123,256.00

PI: Steindler, D.A.

Grant Title: Evelyn F. McKnight Brain Research Program in Age-Related Memory Loss
Agency: UF Foundation
 Project Dates: 4/14/08 - 4/13/14
 Award: \$500,000.00

PI: Steindler, D.A.

Grant Title: McKnight Brain Research Program
Agency: UF Foundation
 Project Dates: 4/14/08 - 4/13/14
 Award: \$500,000.00

PI: Steindler, D.A.

Grant Title: Brain and Spinal Cord Injury Research
Agency: Florida Department of Health
 Project Dates: 7/1/06 - 6/30/11
 Award: \$1,000,000.00

PI: Steindler, D.A.

Grant Title: Stem/Progenitor Cell Protection for Parkinsons Disease
Agency: National Institutes of Health
 Project Dates: 7/1/07 - 3/31/12
 Award: \$317,333.00

PI: Steindler, D.A.

Grant Title: Bioengineered Colorectal Tissue for Repairing Age and Disease Associated Damage
Agency: UF Foundation
 Project Dates: 3/1/09 - 2/28/10
 Award: \$75,000.00

PI: Steindler, D.A.

Grant Title: Regenerating Cortical Neural Circuitry
Agency: UF Foundation
 Project Dates: 3/1/09 - 2/28/11
 Award: \$75,000.00

PI: Steindler, D.A.

Grant Title: Salamander / Alveolar Regeneration
Agency: UF Foundation
 Project Dates: 3/1/09 - 2/28/11
 Award: \$75,000.00

PI: Steindler, D.A.

Grant Title: Tyler's Hope For a Dystonia Cure
Agency: Tyler's Hope For a Dystonia Cure
 Project Dates: 9/10/08 - 9/9/10
 Award: \$144,386.00

PI: Steindler, D.A.

Grant Title: Florida Center for Brain Tumor Research
Agency: Florida Department of Health
 Project Dates: 9/23/09 - 6/30/10
 Award: \$250,000.00

PI: Steindler, D.A.

Grant Title: Validation of a Novel Genetic Model for Neural Regeneration
Agency: National Institutes of Health
 Project Dates: 9/30/09 - 8/31/11
 Award: \$54,411.00

PI: Stewart, G.R.

Grant Title: Fe Pnictide and F-Electron Novel Materials: Magnetism, Superconductivity, and Quantum Criticality
Agency: U.S. Department of Energy
 Project Dates: 10/1/09 - 11/30/10
 Award: \$150,000.00

PI: Sullivan, N.S.

Grant Title: National High Magnetic Field Laboratory--High B/T Facility
Agency: Florida State University
 Project Dates: 1/1/08 - 12/31/12
 Award: \$274,904.00

PI: Sullivan, N.S.

Grant Title: NMR Studies of ³He Impurities in Solid ⁴He
Agency: Florida State University
 Project Dates: 5/1/08 - 4/30/10
 Award: \$81,472.00

PI: Sullivan, N.S.

Grant Title: National High Magnetic Field Laboratory--High B/T Facility
Agency: Florida State University
 Project Dates: 1/1/08 - 12/31/12
 Award: \$112,468.00

PI: Talham, D.R.

Grant Title: Miscellaneous Donors
Agency: Miscellaneous Donors
 Project Dates: 7/1/85 - 6/30/10
 Award: \$10,374.00

PI: Talham, D.R.

Grant Title: American Chemical Society/Hach Scientific Foundation Scholarship
Agency: American Chemical Society
 Project Dates: 5/1/09 - 4/30/10
 Award: \$12,000.00

PI: Talham, D.R.

Grant Title: Miscellaneous Donors
Agency: Miscellaneous Donors
 Project Dates: 7/1/85 - 6/30/10
 Award: \$800.00

PI: Vandenborne, K.H.

Grant Title: Magnetic Resonance Imaging and Biomarkers for Muscular Dystrophy
Agency: Parent Project Muscular Dystrophy
 Project Dates: 2/9/09 - 4/30/10
 Award: \$153,668.00

PI: Vandenborne, K.H.

Grant Title: MRI Assessment of Ptc124 Treatment in Boys with DMD
Agency: Muscular Dystrophy Association
 Project Dates: 7/1/09 - 6/30/12
 Award: \$101,189.00

PI: Vandenborne, K.H.

Grant Title: Modulation of Muscle Growth for Muscle Distrophies
Agency: University of Pennsylvania
 Project Dates: 6/1/09 - 5/31/10
 Award: \$29,778.00

PI: Vandenborne, K.H.

Grant Title: MR Monitoring of Ptc124 Treatment in DMD

Agency: National Institutes of Health
Project Dates: 9/30/09 - 8/31/11
Award: \$326,432.00

PI: Vandenborne, K.H.

Grant Title: Interdisciplinary Training in Rehabilitation and Neuromuscular Plasticity

Agency: National Institutes of Health
Project Dates: 6/11/03 - 4/30/13
Award: \$224,058.00

PI: Vandenborne, K.H.

Grant Title: Molecular Signatures of Muscle Rehabilitation after Limb Disuse

Agency: National Institutes of Health
Project Dates: 9/30/09 - 9/29/10
Award: \$138,436.00

PI: Vandenborne, K.H.

Grant Title: Therapeutic Strategies to Augment Muscle Rehabilitation

Agency: National Institutes of Health
Project Dates: 9/30/09 - 8/31/11
Award: \$584,631.00

PI: Vandenborne, K.H.

Grant Title: MRI Assessment of Ptc124 Treatment in Boys with DMD

Agency: Muscular Dystrophy Association
Project Dates: 7/1/09 - 6/30/12
Award: \$25,106.00

PI: Vandenborne, K.H.

Grant Title: Viral Mediated Igf-1 Gene Transfer and Locomotor Training after Sci...

Agency: The Craig H. Neilsen Foundation
Project Dates: 9/1/08 - 8/31/10
Award: \$60,000.00

PI: Vandenborne, K.H.

Grant Title: Therapeutic Strategies to Augment Muscle Rehabilitation

Agency: National Institutes of Health
Project Dates: 9/30/09 - 8/31/11
Award: \$66,323.00

PI: Vandenborne, K.H.

Grant Title: MR Monitoring of Ptc124 Treatment in DMD

Agency: National Institutes of Health
Project Dates: 9/30/09 - 8/31/11
Award: \$24,926.00

PI: Walter, G.A.

Grant Title: Intelligent Microtome Instrumentation

Agency: Barlow Scientific
Project Dates: 3/9/09 - 1/31/10
Award: \$15,000.00

PI: Walter, G.A.

Grant Title: Adult Hemangioblast/Hsc Recruitment and Maintenance

Agency: National Institutes of Health
Project Dates: 3/15/06 - 2/28/10
Award: \$14,894.00

PI: Walter, G.A.

Grant Title: Magnetic Resonance Imaging and Biomarkers for Muscular Dystrophy

Agency: Parent Project Muscular Dystrophy
Project Dates: 2/9/09 - 4/30/10
Award: \$12,576.00

PI: Walter, G.A.

Grant Title: Modulation of Muscle Growth for Muscle Dystrophies

Agency: University of Pennsylvania
Project Dates: 6/1/09 - 5/31/10
Award: \$10,164.00

PI: Walter, G.A.

Grant Title: Core D: Gene Therapy Using Viral Vector for Lung and Cardiovascular Disease

Agency: National Institutes of Health
Project Dates: 9/1/08 - 6/30/13
Award: \$268,569.00

PI: Walter, G.A.

Grant Title: MR Monitoring of Ptc124 Treatment in DMD

Agency: National Institutes of Health
Project Dates: 9/30/09 - 8/31/11
Award: \$16,058.00

PI: Walter, G.A.

Grant Title: Therapeutic Strategies to Augment Muscle Rehabilitation

Agency: National Institutes of Health
Project Dates: 9/30/09 - 8/31/11
Award: \$138,787.00

Appendix A: 2009 User Facility Statistics

DC Field Facility

By the numbers: *About our users*

A user is an individual or a member of a research group that is allocated magnet time. The user does not have to be "on site" for the experiment. A researcher who sends samples for analysis; a scientist who uses new lab technologies to conduct experiments remotely; or a PI who sends students to the Magnet Lab, are all considered users. All user numbers reflect distinct individuals, i.e. if a user has multiple projects (different scientific thrusts) or is allocated magnet time more than once during the year, he/she is counted only once.

Table 1. DC Field Facility: User Demographics, Calendar Year 2009

DC Field Facility	Users	Female	Minority ¹	On-site ² Users ⁶	Remote Users ^{3,6}	Users Sending Sample ^{4,6}
Number of Senior Investigators, U.S.	144	10	2	144	0	0
Number of Senior Investigators, non-U.S.	59	8	0	59	0	0
Number of Postdocs, U.S.	44	6	3	40	0	0
Number of Postdocs, non-U.S.	11	2	0	11	0	0
Number of Students ⁵ , U.S.	74	15	2	80	0	0
Number of Students ⁵ , non-U.S.	26	5	0	26	0	0
TOTAL	358	46	7	360	0	0

¹ Minority status includes American Indian, Alaska Native, Black or African American, Hispanic, Native Hawaiian or other Pacific Islander. Minority status excludes Asian and White-Not of Hispanic Origin

² Users at the Magnet Lab facility operating the magnet. Not all users on the project must physically come to the lab; if one or more come, then all members of the group are counted in this category.

³ Users conducting the experiment remotely.

⁴ Experiments in which the sample was sent by an external PI and the experiment was conducted by in-house user support personnel in service mode. No member of the group comes to the lab, and all are counted in this category.

⁵ "Students" generally refers to graduate students, but may include a few undergraduate students.

⁶ The total of on-site users, remote users, and users sending samples will equal the total number of users.

Table 2. DC Field Facility: User Affiliations, CY 2009

DC Field Facility	Users	NHMFL-Affiliated Users ¹	Local Users ¹	University Users ^{2,4}	Industry Users ⁴	National Lab Users ^{3,4}
Number of Senior Investigators, U.S.	144	56	3	73	9	62
Number of Senior Investigators, non-U.S.	59	0	0	41	2	16
Number of Postdocs, U.S.	44	19	0	18	0	26
Number of Postdocs, non-U.S.	11	0	0	6	0	5
Number of Students, U.S.	74	18	4	56	0	18
Number of Students, non-U.S.	26	0	0	24	0	2
TOTAL	358	93	7	218	11	129

¹ NHMFL-Affiliated users are defined as anyone in the lab's personnel system [i.e. on our Web site/directory], even if they travel to another site.

Local users are defined as any non-NHMFL-Affiliated researchers originating at any of the institutions in proximity to the MagLab sites (i.e. researchers at FSU, UF, FAMU, or LANL), even if they travel to another site.

The sum of NHMFL-Affiliated and Local users equals what was formerly referred to as "Internal Investigators".

² In addition to external users, all users with primary affiliations at FSU, UF, or FAMU are reported in this category, even if they are also NHMFL associates.

³ In addition to external users, users with primary affiliations at NHMFL/LANL are reported in this category.

⁴ The total of university, industry, and national lab users will equal the total number of users.

Table 3. DC Field Facility: Users by Discipline, CY 2009

DC Field Facility	Users	Condensed Matter Physics	Chemistry, Geochemistry	Engineering	Magnets, Matls., Testing, Instrum.	Biology, Biochem., Biophys.
Number of Senior Investigators, U.S.	144	96	17	1	24	6
Number of Senior Investigators, non-U.S.	59	55	2	1	0	1
Number of Postdocs, U.S.	44	34	3	1	4	2
Number of Postdocs, non-U.S.	11	11	0	0	0	0
Number of Students, U.S.	74	66	4	1	1	2
Number of Students, non-U.S.	26	22	0	1	3	0
TOTAL	358	284	26	5	32	11

DC Field Facility**By the numbers: *About our projects*****Table 4. DC Field Facility:** Requests for Magnet Time, CY 2009

Requests for Magnet Time	Requests Granted	Requests Deferred/Declined
374	265 (71%)	109 (29%)

Note: A request for magnet time was defined as a request for one week of time. An application for two weeks of time was counted as two requests.

Table 5. DC Field Facility: Research Projects¹ Profile, with magnet time in CY 2009

	Total	Minority ²	Female ³	Condensed Matter Physics	Chemistry, Geochem.	Engineering	Magnets, Matls., Testing, Instrum.	Biology, Biochem., Biophys.
Number of Projects	119	0	6	94	6	2	14	3

¹ A "project" may have associated with it a single experiment or a group of closely related experiments. A PI may have more than one project.

² The number of projects satisfying one of the following two conditions: (a) the PI is a minority OR (b) the PI is a non-minority working at a minority-serving college or university AND the project includes minority participants.

³ The number of projects satisfying one of the following two conditions: (a) the PI is a female OR (b) the PI is a male working at a college or university for women AND the project includes female participants.

DC Field Facility**By the numbers: *About our magnet usage*****Table 6. DC Field Facility: Operations Statistics, CY 2009**

	Resistive Magnets & Hybrid	Superconducting Magnets	Total Days Allocated / User Affil.	Percentage Allocated / User Affil.
Number of Magnet Days¹				
NHMFL-Affiliated ²	186.1	147.0	333.1	20.1%
Local ²	.0	46.0	46.0	2.8%
U.S. University	221.9	392.0	613.9	37.0%
U.S. Govt. Lab.	70.5	56.0	126.5	7.6%
U.S. Industry	7.9	.0	7.9	.5%
Non-U.S.	149.1	56.0	205.1	12.3%
Test, Calibration, Set-up, Maintenance	97.4	175.0	272.4	16.4%
Idle	.0	56.0	56.0	3.4%
TOTAL	732.8	928.0	1,660.8	100.0%

1 User Units are defined as magnet days. For the DC Field Facility, one magnet day is defined as 7 hours in a water-cooled resistive or hybrid magnet. Using this definition, a typical 24-hour day in the DC Field Facility contains three or four "magnet days". For experiments in the superconducting magnets, one "magnet day" is defined as 24 hours of use.

2 NHMFL-Affiliated users are defined as anyone in the lab's personnel system [i.e. on our Web site/directory], even if they travel to another site.
Local users are defined as any non-NHMFL-Affiliated researchers originating at any of the institutions in proximity to the MagLab sites (i.e. researchers at FSU, UF, FAMU, or LANL), even if they travel to another site.
The sum of NHMFL-Affiliated and Local usage equals what was formerly referred to as usage by "Internal Investigators".

Table 7. DC Field Facility: Operations by Discipline, CY 2009

	Total Days ¹ Allocated / User Affil.	Condensed Matter Physics	Chemistry, Geochem.	Engineering	Magnets, Matls, Testing, Instrum.	Biology, Biochem., Biophys.
NHMFL ²	333.1	299.5	2.0	0.0	22.1	9.5
Local ²	46.0	46.0	0.0	0.0	0.0	0.0
U.S. University	613.9	562.6	42.6	0.0	3.4	5.4
U.S. Govt. Lab.	126.5	123.0	3.5	0.0	0.0	0.0
U.S. Industry	7.9	0.0	0.0	0.0	7.9	0.0
Non-U.S.	205.1	189.1	5.0	0.0	11.0	0.0
Test, Calibration, Set-up, Maintenance	272.4	0.0	0.0	0.0	272.4	0.0
Idle	56.0	n/a ³	n/a	n/a	n/a	n/a
TOTAL	1660.8	1220.2	53.0	0.0	316.8	14.9

1 User Units are defined as magnet days. For the DC Field Facility, one magnet day is defined as 7 hours in a water-cooled resistive or hybrid magnet. Using this definition, a typical 24-hour day in the DC Field Facility contains three or four "magnet days". For experiments in the superconducting magnets, one "magnet day" is defined as 24 hours of use.

2 NHMFL-Affiliated users are defined as anyone in the lab's personnel system [i.e. on our Web site/directory], even if they travel to another site.
Local users are defined as any non-NHMFL-Affiliated researchers originating at any of the institutions in proximity to the MagLab sites (i.e. researchers at FSU, UF, FAMU, or LANL), even if they travel to another site.
The sum of NHMFL-Affiliated and Local usage equals what was formerly referred to as usage by "Internal Investigators".

3 n/a means: not applicable

Appendix A: 2009 User Facility Statistics

Pulsed Field Facility

By the numbers: *About our users*

A user is an individual or a member of a research group that is allocated magnet time. The user does not have to be "on site" for the experiment. A researcher who sends samples for analysis; a scientist who uses new lab technologies to conduct experiments remotely; or a PI who sends students to the Magnet Lab, are all considered users. All user numbers reflect distinct individuals, i.e. if a user has multiple projects (different scientific thrusts) or is allocated magnet time more than once during the year, he/she is counted only once.

Table 1. Pulsed Field Facility: User Demographics, Calendar Year 2009

Pulsed Field Facility	Users	Female	Minority ¹	On-site ² Users ⁶	Remote Users ^{3,6}	Users Sending Sample ^{4,6}
Number of Senior Investigators, U.S.	74	3	0	72	N/A	2
Number of Senior Investigators, non-U.S.	31	3	4	25	N/A	6
Number of Postdocs, U.S.	25	2	1	22	N/A	3
Number of Postdocs, non-U.S.	10	2	0	9	N/A	1
Number of Students ⁵ , U.S.	29	2	1	29	N/A	0
Number of Students ⁵ , non-U.S.	8	0	2	8	N/A	0
TOTAL	177	12	8	165	N/A	12

¹ Minority status includes American Indian, Alaska Native, Black or African American, Hispanic, Native Hawaiian or other Pacific Islander. Minority status excludes Asian and White-Not of Hispanic Origin

² Users at the Magnet Lab facility operating the magnet. Not all users on the project must physically come to the lab; if one or more come, then all members of the group are counted in this category.

³ Users conducting the experiment remotely.

⁴ Experiments in which the sample was sent by an external PI and the experiment was conducted by in-house user support personnel in service mode. No member of the group comes to the lab, and all are counted in this category.

⁵ "Students" generally refers to graduate students, but may include a few undergraduate students.

⁶ The total of on-site users, remote users, and users sending samples will equal the total number of users.

Table 2. Pulsed Field Facility: User Affiliations, CY 2009

Pulsed Field Facility	Users	NHMFL-Affiliated Users ¹	Local Users ¹	University Users ^{2,4}	Industry Users ⁴	National Lab Users ^{3,4}
Number of Senior Investigators, U.S.	74	19	25	21	1	52
Number of Senior Investigators, non-U.S.	31	0	0	31	0	0
Number of Postdocs, U.S.	25	8	5	9	0	16
Number of Postdocs, non-U.S.	10	0	0	10	0	0
Number of Students, U.S.	29	6	0	27	0	2
Number of Students, non-U.S.	8	0	0	8	0	0
TOTAL	177	33	30	106	1	70

¹ NHMFL-Affiliated users are defined as anyone in the lab's personnel system [i.e. on our Web site/directory], even if they travel to another site.

Local users are defined as any non-NHMFL-Affiliated researchers originating at any of the institutions in proximity to the MagLab sites (i.e. researchers at FSU, UF, FAMU, or LANL), even if they travel to another site.

The sum of NHMFL-Affiliated and Local users equals what was formerly referred to as "Internal Investigators".

² In addition to external users, all users with primary affiliations at FSU, UF, or FAMU are reported in this category, even if they are also NHMFL associates.

³ In addition to external users, users with primary affiliations at NHMFL/LANL are reported in this category.

⁴ The total of university, industry, and national lab users will equal the total number of users.

Table 3. Pulsed Field Facility: Users by Discipline, CY 2009

Pulsed Field Facility	Users	Condensed Matter Physics	Chemistry, Geochemistry	Engineering	Magnets, Matls., Testing, Instrum.	Biology, Biochem., Biophys.
Number of Senior Investigators, U.S.	74	69	2	0	3	0
Number of Senior Investigators, non-U.S.	31	30	0	0	1	0
Number of Postdocs, U.S.	25	24	0	0	1	0
Number of Postdocs, non-U.S.	10	10	0	0	0	0
Number of Students, U.S.	29	28	0	0	1	0
Number of Students, non-U.S.	8	8	0	0	0	0
TOTAL	177	169	2	0	6	0

Pulsed Field Facility**By the numbers: *About our projects*****Table 4. Pulsed Field Facility:** Requests for Magnet Time, CY 2009

Requests for Magnet Time	Requests Granted	Requests Deferred/Declined
126	111	15

Table 5. Pulsed Field Facility: Research Projects¹ Profile, with magnet time in CY 2009

	Total	Minority ²	Female ³	Condensed Matter Physics	Chemistry, Geochem.	Engineering	Magnets, Matls., Testing, Instrum.	Biology, Biochem., Biophys.
Number of Projects	108	7	9	101	1	0	6	0

¹ A "project" may have associated with it a single experiment or a group of closely related experiments. A PI may have more than one project.

² The number of projects satisfying one of the following two conditions: (a) the PI is a minority OR (b) the PI is a non-minority working at a minority-serving college or university AND the project includes minority participants.

³ The number of projects satisfying one of the following two conditions: (a) the PI is a female OR (b) the PI is a male working at a college or university for women AND the project includes female participants.

Pulsed Field Facility**By the numbers: *About our magnet usage*****Table 6. Pulsed Field Facility: Operations Statistics, CY 2009**

	Super-cond.	Short Pulse	Mid Pulse	Long Pulse	100T	Single Turn	Total Days Allocated / User Affil.	Percentage Allocated / User Affil.
Number of Magnet Days¹								
NHMFL-Affiliated ²	120	54	94	14	17	9	308	23.5%
Local ²	154	41	12	0	5	14	226	17.3%
U.S. University	129	83	0	0	5	23	240	18.3%
U.S. Govt. Lab.	9	5	0	0	0	0	14	1.1%
U.S. Industry	0	5	0	0	0	3	8	0.6%
Non-U.S.	230	188	32	5	19	0	474	36.2%
Test, Calibration, Set-up, Maintenance	20	10	0	0	5	5	40	3.0%
Idle	0	0	0	0	0	0	0	0%
TOTAL	662	386	138	19	51	54	1310	100%

¹ User Units are defined as magnet days. For the Pulsed Field Facility, one magnet day is defined as 12 hours in any pulsed magnet system. For experiments in the superconducting magnets, one "magnet day" is defined as 24 hours of use.

² NHMFL-Affiliated users are defined as anyone in the lab's personnel system [i.e. on our Web site/directory], even if they travel to another site.

Local users are defined as any non-NHMFL-Affiliated researchers originating at any of the institutions in proximity to the MagLab sites (i.e. researchers at FSU, UF, FAMU, or LANL), even if they travel to another site.

The sum of NHMFL-Affiliated and Local usage equals what was formerly referred to as usage by "Internal Investigators".

Table 7. Pulsed Field Facility: Operations by Discipline, CY 2009

	Total Days ¹ Allocated / User Affil.	Condensed Matter Physics	Chemistry, Geochem.	Engineering	Magnets, Matls, Testing, Instrum.	Biology, Biochem., Biophys.
NHMFL-Affiliated ²	308	234	0	0	74	0
Local ²	226	209	6	0	11	0
U.S. University	240	214	26	0	0	0
U.S. Govt. Lab.	14	14	0	0	0	0
U.S. Industry	8	8	0	0	0	0
Non-U.S.	474	439	0	0	35	0
Test, Calibration, Set-up, Maintenance	40	0	0	0	40	0
Idle	0	n/a ³	n/a	n/a	n/a	n/a
TOTAL	1310	1118	32	0	160	0

¹ User Units are defined as magnet days. For the Pulsed Field Facility, one magnet day is defined as 12 hours in any pulsed magnet system. For experiments in the superconducting magnets, one "magnet day" is defined as 24 hours of use.

² NHMFL-Affiliated users are defined as anyone in the lab's personnel system [i.e. on our Web site/directory], even if they travel to another site.

Local users are defined as any non-NHMFL-Affiliated researchers originating at any of the institutions in proximity to the MagLab sites (i.e. researchers at FSU, UF, FAMU, or LANL), even if they travel to another site.

The sum of NHMFL-Affiliated and Local usage equals what was formerly referred to as usage by "Internal Investigators".

³ n/a means not applicable.

Appendix A: 2009 User Facility Statistics

High B/T Facility

By the numbers: *About our users*

A user is an individual or a member of a research group that is allocated magnet time. The user does not have to be "on site" for the experiment. A researcher who sends samples for analysis; a scientist who uses new lab technologies to conduct experiments remotely; or a PI who sends students to the Magnet Lab, are all considered users. All user numbers reflect distinct individuals, i.e. if a user has multiple projects (different scientific thrusts) or is allocated magnet time more than once during the year, he/she is counted only once.

Table 1. High B/T Facility: User Demographics, Calendar Year 2009

High B/T Facility	Users	Female	Minority ¹	On-site ^{2,6} Users	Remote Users ^{3,6}	Users Sending Sample ^{4,6}
Number of Senior Investigators, U.S.	30	2	0	25	0	5
Number of Senior Investigators, non-U.S.	8	1	0	5	1	2
Number of Postdocs, U.S.	2	0	0	2	0	0
Number of Postdocs, non-U.S.	0	0	0	0	0	0
Number of Students ⁵ , U.S.	1	1	0	1	0	0
Number of Students ⁵ , non-U.S.	0	0	0	0	0	0
TOTAL	41	4	0	33	1	7

¹ Minority status includes American Indian, Alaska Native, Black or African American, Hispanic, Native Hawaiian or other Pacific Islander. Minority status excludes Asian and White-Not of Hispanic Origin

² Users at the Magnet Lab facility operating the magnet. Not all users on the project must physically come to the lab; if one or more come, then all members of the group are counted in this category.

³ Users conducting the experiment remotely.

⁴ Experiments in which the sample was sent by an external PI and the experiment was conducted by in-house user support personnel in service mode. No member of the group comes to the lab, and all are counted in this category.

⁵ "Students" generally refers to graduate students, but may include a few undergraduate students.

⁶ The total of on-site users, remote users, and users sending samples will equal the total number of users.

Table 2. High B/T Facility: User Affiliations, CY 2009

High B/T Facility	Users	NHMFL-Affiliated Users ¹	Local Users ¹	University Users ^{2,4}	Industry Users ⁴	National Lab Users ^{3,4}
Number of Senior Investigators, U.S.	30	9	11	26	2	2
Number of Senior Investigators, non-U.S.	8	0	0	6	0	2
Number of Postdocs, U.S.	2	1	1	2	0	0
Number of Postdocs, non-U.S.	0	0	0	0	0	0
Number of Students, U.S.	1	0	0	1	0	0
Number of Students, non-U.S.	0	0	0	0	0	0
TOTAL	41	10	12	35	2	4

¹ NHMFL-Affiliated users are defined as anyone in the lab's personnel system [i.e. on our Web site/directory], even if they travel to another site.

Local users are defined as any non-NHMFL-Affiliated researchers originating at any of the institutions in proximity to the MagLab sites (i.e. researchers at FSU, UF, FAMU, or LANL), even if they travel to another site.

The sum of NHMFL-Affiliated and Local users equals what was formerly referred to as "Internal Investigators".

² In addition to external users, all users with primary affiliations at FSU, UF, or FAMU are reported in this category, even if they are also NHMFL associates.

³ In addition to external users, users with primary affiliations at NHMFL/LANL are reported in this category.

⁴ The total of university, industry, and national lab users will equal the total number of users.

Table 3. High B/T Facility: Users by Discipline, CY 2009

High B/T Facility	Users	Condensed Matter Physics	Chemistry, Geochemistry	Engineering	Magnets, Matls., Testing, Instrum.	Biology, Biochem., Biophys.
Number of Senior Investigators, U.S.	30	27	0	0	3	0
Number of Senior Investigators, non-U.S.	8	8	0	0	0	0
Number of Postdocs, U.S.	2	2	0	0	0	0
Number of Postdocs, non-U.S.	0	0	0	0	0	0
Number of Students, U.S.	1	1	0	0	0	0
Number of Students, non-U.S.	0	0	0	0	0	0
TOTAL	41	38	0	0	3	0

High B/T Facility**By the numbers: *About our projects*****Table 4. High B/T Facility:** Requests for Magnet Time, CY 2009

Requests for Magnet Time	Requests Granted	Requests Deferred/Declined
7	5	2

Table 5. High B/T Facility: Research Projects¹ Profile, with magnet time in CY 2009

	Total	Minority ²	Female ³	Condensed Matter Physics	Chemistry, Geochem.	Engineering	Magnets, Matls., Testing, Instrum.	Biology, Biochem., Biophys.
Number of Projects	8	0	2	7	0	0	1	0

¹ A "project" may have associated with it a single experiment or a group of closely related experiments. A PI may have more than one project.

² The number of projects satisfying one of the following two conditions: (a) the PI is a minority OR (b) the PI is a non-minority working at a minority-serving college or university AND the project includes minority participants.

³ The number of projects satisfying one of the following two conditions: (a) the PI is a female OR (b) the PI is a male working at a college or university for women AND the project includes female participants.

High B/T Facility**By the numbers: *About our magnet usage*****Table 6. High B/T Facility: Operations Statistics, CY 2009**

	Total Days Allocated / User Affil.	Percentage Allocated / User Affil.
Number of Magnet Days¹		
NHMFL-Affiliated ²	135	21%
Local ²	0	0
U.S. University	350	53%
U.S. Govt. Lab.	75	11%
U.S. Industry	0	0
Non-U.S.	0	0
Test, Calibration, Set-up, Maintenance	95	15%
Idle	0	0
TOTAL	655	100%

1 User Units are defined as magnet days. For the High B/T Facility, one magnet day is defined 24 hours in the superconducting magnets.

2 NHMFL-Affiliated users are defined as anyone in the lab's personnel system [i.e. on our Web site/directory], even if they travel to another site.

Local users are defined as any non-NHMFL-Affiliated researchers originating at any of the institutions in proximity to the MagLab sites (i.e. researchers at FSU, UF, FAMU, or LANL), even if they travel to another site.

The sum of NHMFL-Affiliated and Local usage equals what was formerly referred to as usage by "Internal Investigators".

Table 7. High B/T Facility: Operations by Discipline, CY 2009

	Total Days ¹ Allocated / User Affil.	Condensed Matter Physics	Chemistry, Geochem.	Engineering	Magnets, Matls, Testing, Instrum.	Biology, Biochem., Biophys.
NHMFL-Affiliated ²	135	135	0	0	0	0
Local ²	0	0	0	0	0	0
U.S. University	350	350	0	0	0	0
U.S. Govt. Lab.	75	75	0	0	0	0
U.S. Industry	0	0	0	0	0	0
Non-U.S.	0	0	0	0	0	0
Test, Calibration, Set-up, Maintenance	95	31	0	0	64	0
Idle	0	n/a ³	n/a	n/a	n/a	n/a
TOTAL	655	591	0	0	64	0

1 User Units are defined as magnet days. For the High B/T Facility, one magnet day is defined 24 hours in the superconducting magnets.

2 NHMFL-Affiliated users are defined as anyone in the lab's personnel system [i.e. on our Web site/directory], even if they travel to another site.

Local users are defined as any non-NHMFL-Affiliated researchers originating at any of the institutions in proximity to the MagLab sites (i.e. researchers at FSU, UF, FAMU, or LANL), even if they travel to another site.

The sum of NHMFL-Affiliated and Local usage equals what was formerly referred to as usage by "Internal Investigators".

3 n/a means not applicable

Appendix A: 2009 User Facility Statistics

Nuclear Magnetic Resonance (NMR) Facility

By the numbers: *About our users*

A user is an individual or a member of a research group that is allocated magnet time. The user does not have to be "on site" for the experiment. A researcher who sends samples for analysis; a scientist who uses new lab technologies to conduct experiments remotely; or a PI who sends students to the Magnet Lab, are all considered users. All user numbers reflect distinct individuals, i.e. if a user has multiple projects (different scientific thrusts) or is allocated magnet time more than once during the year, he/she is counted only once.

Table 1. NMR Facility: User Demographics, Calendar Year 2009

NMR Facility	Users	Female	Minority ¹	On-site ^{2,6} Users	Remote Users ^{3,6}	Users Sending Sample ^{4,6}
Number of Senior Investigators, U.S.	76	15	3	60	6	10
Number of Senior Investigators, non-U.S.	17	0	0	10	0	7
Number of Postdocs, U.S.	20	3	2	16	2	2
Number of Postdocs, non-U.S.	1	0	0	1	0	0
Number of Students ⁵ , U.S.	56	19	4	47	4	5
Number of Students ⁵ , non-U.S.	2	1	0	2	0	0
TOTAL	172	38	9	136	12	24

¹ Minority status includes American Indian, Alaska Native, Black or African American, Hispanic, Native Hawaiian or other Pacific Islander. Minority status excludes Asian and White-Not of Hispanic Origin

² Users at the Magnet Lab facility operating the magnet. Not all users on the project must physically come to the lab; if one or more come, then all members of the group are counted in this category.

³ Users conducting the experiment remotely.

⁴ Experiments in which the sample was sent by an external PI and the experiment was conducted by in-house user support personnel in service mode. No member of the group comes to the lab, and all are counted in this category.

⁵ "Students" generally refers to graduate students, but may include a few undergraduate students.

⁶ The total of on-site users, remote users, and users sending samples will equal the total number of users.

Table 2. NMR Facility: User Affiliations, CY 2009

NMR Facility	Users	NHMFL-Affiliated Users ¹	Local Users ¹	University Users ^{2,4}	Industry Users ⁴	National Lab Users ^{3,4}
Number of Senior Investigators, U.S.	76	26	7	58	6	12
Number of Senior Investigators, non-U.S.	17	0	0	17	0	0
Number of Postdocs, U.S.	20	12	1	15	0	5
Number of Postdocs, non-U.S.	1	0	0	1	0	0
Number of Students, U.S.	56	26	11	56	0	0
Number of Students, non-U.S.	2	0	0	2	0	0
TOTAL	172	64	19	149	6	17

¹ NHMFL-Affiliated users are defined as anyone in the lab's personnel system [i.e. on our Web site/directory], even if they travel to another site.

Local users are defined as any non-NHMFL-Affiliated researchers originating at any of the institutions in proximity to the MagLab sites (i.e. researchers at FSU, UF, FAMU, or LANL), even if they travel to another site.

The sum of NHMFL-Affiliated and Local users equals what was formerly referred to as "Internal Investigators".

² In addition to external users, all users with primary affiliations at FSU, UF, or FAMU are reported in this category, even if they are also NHMFL associates.

³ In addition to external users, users with primary affiliations at NHMFL/LANL are reported in this category.

⁴ The total of university, industry, and national lab users will equal the total number of users.

Table 3. NMR Facility: Users by Discipline, CY 2009

NMR Facility	Users	Condensed Matter Physics	Chemistry, Geochemistry	Engineering	Magnets, Matls., Testing, Instrum.	Biology, Biochem., Biophys.
Number of Senior Investigators, U.S.	76	1	5	13	4	53
Number of Senior Investigators, non-U.S.	17	0	7	1	0	9
Number of Postdocs, U.S.	20	0	1	1	0	18
Number of Postdocs, non-U.S.	1	0	1	0	0	0
Number of Students, U.S.	56	1	5	12	4	34
Number of Students, non-U.S.	2	0	1	0	0	1
TOTAL	172	2	20	27	8	115

NMR Facility**By the numbers: *About our projects*****Table 4. NMR Facility:** Requests for Magnet Time, CY 2009

Requests for Magnet Time	Requests Granted	Requests Deferred/Declined
2314	2149 (93%)	165 (7%)

Table 5. NMR Facility: Research Projects¹ Profile, with magnet time in CY 2009

	Total	Minority ²	Female ³	Condensed Matter Physics	Chemistry, Geochem.	Engineering	Magnets, Matls., Testing, Instrum.	Biology, Biochem., Biophys.
Number of Projects	90	2	16	0	17	11	5	57

¹ A "project" may have associated with it a single experiment or a group of closely related experiments. A PI may have more than one project.

² The number of projects satisfying one of the following two conditions: (a) the PI is a minority OR (b) the PI is a non-minority working at a minority-serving college or university AND the project includes minority participants.

³ The number of projects satisfying one of the following two conditions: (a) the PI is a female OR (b) the PI is a male working at a college or university for women AND the project includes female participants.

NMR Facility**By the numbers: *About our magnet usage*****Table 6. NMR Facility:** Operations Statistics, CY 2009

	900	830*	720	600	600WB	600WB2	Total Days Allocated / User Affil.	Percentage Allocated / User Affil.
Number of Magnet Days¹								
NHMFL-Affiliated ²	127	69	96	115	108	63	578	26%
Local ²	84	18	96	36	106	155	495	23%
U.S. University	124	189	71	182	88	130	784	36%
U.S. Govt. Lab.	0	0	91	0	36	0	127	6%
U.S. Industry	0	0	0	0	0	0	0	0%
Non-U.S.	5	69	0	0	0	0	74	3%
Test, Calibration, Set-up, Maintenance	23	10	1	27	20	10	91	4%
Idle	2	10	10	5	7	7	41	2%
TOTAL	365	365	365	365	365	365	2190	100%

1 User Units are defined as magnet days. For the NMR Facility in Tallahassee, one magnet day is 24 hours in the superconducting magnets.

2 NHMFL-Affiliated users are defined as anyone in the lab's personnel system [i.e. on our Web site/directory], even if they travel to another site.

3 Local users are defined as any non-NHMFL-Affiliated researchers originating at any of the institutions in proximity to the MagLab sites (i.e. researchers at FSU, UF, FAMU, or LANL), even if they travel to another site.
The sum of NHMFL-Affiliated and Local usage equals what was formerly referred to as usage by "Internal Investigators".

Table 7. NMR Facility: Operations by Discipline, CY 2009

	Total Days ¹ Allocated / User Affil.	Condensed Matter Physics	Chemistry, Geochem.	Engineering	Magnets, Matls, Testing, Instrum.	Biology, Biochem., Biophys.
NHMFL-Affiliated ²	578	0	175	70	0	333
Local ²	495	0	126	116	0	253
U.S. University	784	0	335	56	0	393
U.S. Govt. Lab.	127	0	0	0	0	127
U.S. Industry	0	0	0	0	0	0
Non-U.S.	74	0	37	32	0	5
Test, Calibration, Set-up, Maintenance	91	0	0	0	91	0
Idle	41	n/a ³	n/a	n/a	n/a	n/a
TOTAL	2190	0	673	274	91	1111

1 User Units are defined as magnet days. For the NMR Facility in Tallahassee, one magnet day is 24 hours in the superconducting magnets.

2 NHMFL-Affiliated users are defined as anyone in the lab's personnel system [i.e. on our Web site/directory], even if they travel to another site.

Local users are defined as any non-NHMFL-Affiliated researchers originating at any of the institutions in proximity to the MagLab sites (i.e. researchers at FSU, UF, FAMU, or LANL), even if they travel to another site.

The sum of NHMFL-Affiliated and Local usage equals what was formerly referred to as usage by "Internal Investigators".

3 n/a means: not applicable

Appendix A: 2009 User Facility Statistics

Advanced Magnetic Resonance Imaging and Spectroscopy (AMRIS) Facility

By the numbers: *About our users*

A user is an individual or a member of a research group that is allocated magnet time. The user does not have to be "on site" for the experiment. A researcher who sends samples for analysis; a scientist who uses new lab technologies to conduct experiments remotely; or a PI who sends students to the Magnet Lab, are all considered users. All user numbers reflect distinct individuals, i.e. if a user has multiple projects (different scientific thrusts) or is allocated magnet time more than once during the year, he/she is counted only once.

Table 1. AMRIS Facility: User Demographics, Calendar Year 2009

AMRIS	Users	Female	Minority ¹	On-site ^{2,6} Users	Remote Users ^{3,6}	Users Sending Sample ^{4,6}
Number of Senior Investigators, U.S.	57	12	5	30	4	23
Number of Senior Investigators, non-U.S.	13	1	3	5	5	3
Number of Postdocs, U.S.	9	3	1	7	1	1
Number of Postdocs, non-U.S.	9	2	1	9	0	0
Number of Students ⁵ , U.S.	35	9	6	29	1	5
Number of Students ⁵ , non-U.S.	19	5	7	13	2	4
Support and Technical staff, U.S. ⁷	11	2	1	9	0	2
Support and Technical staff, non-U.S. ⁷	9	1	0	1	2	6
TOTAL	162	35	24	103	15	44

1 Minority status includes American Indian, Alaska Native, Black or African American, Hispanic, Native Hawaiian or other Pacific Islander. Minority status excludes Asian and White-Not of Hispanic Origin

2 Users at the Magnet Lab facility operating the magnet. Not all users on the project must physically come to the lab; if one or more come, then all members of the group are counted in this category.

3 Users conducting the experiment remotely.

4 Experiments in which the sample was sent by an external PI and the experiment was conducted by in-house user support personnel in service mode. No member of the group comes to the lab, and all are counted in this category.

5 "Students" generally refers to graduate students, but may include a few undergraduate students.

6 The total of on-site users, remote users, and users sending samples will equal the total number of users.

7 AMRIS collects and reports Staff in a separate, additional category. **For merging with other NHMFL user tables, Staff data will be added to Senior Investigators.**

Table 2. AMRIS Facility: User Affiliations, CY 2009

AMRIS Facility	Users	NHMFL-Affiliated Users ¹	Local Users ¹	University Users ^{2,4}	Industry Users ⁴	National Lab Users ^{3,4}
Number of Senior Investigators, U.S.	57	10	18	49	0	8
Number of Senior Investigators, non-U.S.	13	2	0	13	0	0
Number of Postdocs, U.S.	9	0	5	8	0	1
Number of Postdocs, non-U.S.	9	0	9	9	0	0
Number of Students, U.S.	35	0	27	35	0	0
Number of Students, non-U.S.	19	0	13	18	0	1
Support and Technical staff, U.S. ⁵	11	2	6	10	0	1
Support and Technical staff, non-U.S. ⁵	9	0	1	6	2	1
TOTAL	162	14	79	148	2	12

¹ NHMFL-Affiliated users are defined as anyone in the lab's personnel system [i.e. on our Web site/directory], even if they travel to another site.

Local users are defined as any non-NHMFL-Affiliated researchers originating at any of the institutions in proximity to the MagLab sites (i.e. researchers at FSU, UF, FAMU, or LANL), even if they travel to another site.

The sum of NHMFL-Affiliated and Local users equals what was formerly referred to as "Internal Investigators".

² In addition to external users, all users with primary affiliations at FSU, UF, or FAMU are reported in this category, even if they are also NHMFL associates.

³ In addition to external users, users with primary affiliations at NHMFL/LANL are reported in this category.

⁴ The total of university, industry, and national lab users will equal the total number of users.

⁵ AMRIS collects and reports Staff in a separate, additional category. **For merging with other NHMFL user tables, Staff data will be added to Senior Investigators.**

Table 3. AMRIS Facility: Users by Discipline, CY 2009

AMRIS	Users	Condensed Matter Physics	Chemistry, Geochemistry	Engineering	Magnets, Matls., Testing, Instrum.	Biology, Biochem., Biophys.
Number of Senior Investigators, U.S.	57	0	10	4	0	43
Number of Senior Investigators, non-U.S.	13	0	2	1	0	10
Number of Postdocs, U.S.	9	0	1	0	0	8
Number of Postdocs, non-U.S.	9	0	2	0	0	7
Number of Students, U.S.	35	0	4	3	0	28
Number of Students, non-U.S.	19	0	4	1	0	14
Support and Technical staff, U.S. ¹	11	0	2	2	0	7
Support and Technical staff, non-U.S. ¹	9	0	2	3	0	4
TOTAL	162	0	27	14	0	121

¹ AMRIS collects and reports Staff in a separate, additional category. **For merging with other NHMFL user tables, Staff data will be added to Senior Investigators.**

AMRIS Facility

By the numbers: *About our projects*

Table 4. AMRIS Facility: Requests for Magnet Time, CY 2009

Requests for Magnet Time	Requests Granted	Requests Deferred/Declined
>400	>400	1

Table 5. AMRIS Facility: Research Projects¹ Profile, with magnet time in CY 2009

	Total	Minority ²	Female ³	Condensed Matter Physics	Chemistry, Geochem.	Engineering	Magnets, Matls, Testing, Instrum.	Biology, Biochem., Biophys.
Number of Projects	45	2	14	0	8	2	3	32

- 1 A "project" may have associated with it a single experiment or a group of closely related experiments. A PI may have more than one project.
- 2 The number of projects satisfying one of the following two conditions: (a) the PI is a minority OR (b) the PI is a non-minority working at a minority-serving college or university AND the project includes minority participants.
- 3 The number of projects satisfying one of the following two conditions: (a) the PI is a female OR (b) the PI is a male working at a college or university for women AND the project includes female participants.

AMRIS Facility

By the numbers: *About our magnet usage*

Table 6. AMRIS Facility: Operations Statistics, CY 2009

	500 MHz NMR	600 MHz NMR / MRI	600 MHz cryo	750 MHz wb	4.7 T / 33 cm	11.1 T / 40 cm	3T whole body	Total Days Allocated / User Affil.	Percentage Allocated / User Affil.
Number of Magnet Days¹									
NHMFL-Affiliated ²	18	98	69	77	47	69	22	400	18.2%
Local ²	2	18	11	37	24	9	68	169	7.7%
UF Pilot study ³	9	0	0	0	0	0	0	9	0.4%
U.S. University	37	8	29	13	4	25	0	116	5.3%
U.S. Govt. Lab.	8	7	20	0	0	0	0	35	1.6%
U.S. Industry	7	7	0	0	3	0	0	17	0.8%
Non-U.S.	92	7	38	12	0	5	0	154	7.0%
Development ⁴	37	89	32	85	6	7	1	257	11.7%
Test, Calibration, Set-up, Maintenance ⁵	79	93	123	111	43	18	27	494	22.5%
Idle	69	31	36	23	128	122	137	546	24.8%
TOTAL	358	358	358	358	255	255	255	2197	100%

1 User Units are defined as magnet days. Magnet-day definitions for AMRIS instruments:

Verticals (500, 600s, & 750 MHz), 1 magnet day = 24 hours (7 days/week).

Horizontals (4.7, 11.1, and 3T), 1 magnet day = 8 hours (5 days/week). This accounts for the difficulty in running animal or human studies overnight. There is an annual 7 day holiday shutdown at UF so total days are based on a 51 week calendar.

Magnet days were calculated by adding the total number of real hours used for each instrument and dividing by 24 (vertical) or 8 (horizontal).

Note: Due to the nature of the 4.7 T, 11 T and 3 T studies, almost all studies with external users were collaborative with UF investigators.

2 NHMFL-Affiliated users are defined as anyone in the lab's personnel system [i.e. on our Web site/directory], even if they travel to another site.

Local users are defined as any non-NHMFL-Affiliated researchers originating at any of the institutions in proximity to the MagLab sites (i.e. researchers at FSU, UF, FAMU, or LANL), even if they travel to another site.

The sum of NHMFL-Affiliated and Local usage equals what was formerly referred to as usage by "Internal Investigators".

Note: All of the use in this category was paid by individual investigator grants and not the NHMFL.

3 Pilot studies are awarded to UF investigators from NHMFL funds. **For merging with other NHMFL user tables it will be added to the NHMFL-Affiliated category.**

4 Development was used for several purposes, primarily for establishing new capabilities such as building and testing coils, implementing new pulse sequences, and developing new protocols. **For merging with other NHMFL user tables, Development data will be added to Test, Calibration, Set-up, Maintenance.**

5 Note that each instrument has approximately the same number of hours for maintenance/testing and days are different due to definitions of magnet days on the different instruments.

Table 7. AMRIS Facility: Operations by Discipline, CY 2009

	Total Days ¹ Allocated / User Affil.	Condensed Matter Physics	Chemistry, Geochem.	Engineering	Magnets, Matls, Testing, Instrum.	Biology, Biochem., Biophys.
NHMFL-Affiliated ²	400	0	100	100	0	200
Local ²	169	0	69	0	0	100
UF Pilot study ³	9	0	0	0	0	9
U.S. University	116	0	50	0	0	66
U.S. Govt. Lab.	35	0	15	0	0	20
U.S. Industry	17	0	0	17	0	0
Non-U.S.	154	0	54	0	0	100
Development ⁴	257	0	7	100	100	50
Test, Calibration, Set-up, Maintenance ⁵	494	0	94	100	200	100
Idle	546	n/a	n/a	n/a	n/a	n/a
TOTAL	2197	0	389	317	300	645

n/a means: not applicable

Appendix A: 2009 User Facility Statistics

Electron Magnetic Resonance (EMR) Facility

By the numbers: *About our users*

A user is an individual or a member of a research group that is allocated magnet time. The user does not have to be "on site" for the experiment. A researcher who sends samples for analysis; a scientist who uses new lab technologies to conduct experiments remotely; or a PI who sends students to the Magnet Lab, are all considered users. All user numbers reflect distinct individuals, i.e. if a user has multiple projects (different scientific thrusts) or is allocated magnet time more than once during the year, he/she is counted only once.

Table 1. EMR Facility: User Demographics, Calendar Year 2009

EMR Facility	Users	Female	Minority ¹	On-site ^{2,6} Users	Remote Users ^{3,6}	Users Sending Sample ^{4,6}
Number of Senior Investigators, U.S.	36	3	2	28	0	8
Number of Senior Investigators, non-U.S.	38	4	3	21	0	17
Number of Postdocs, U.S.	9	4	0	6	0	3
Number of Postdocs, non-U.S.	6	2	2	3	0	3
Number of Students ⁵ , U.S.	24	6	4	22	0	2
Number of Students ⁵ , non-U.S.	11	3	1	4	0	7
TOTAL	124	22	12	84	0	40

¹ Minority status includes American Indian, Alaska Native, Black or African American, Hispanic, Native Hawaiian or other Pacific Islander. Minority status excludes Asian and White-Not of Hispanic Origin

² Users at the Magnet Lab facility operating the magnet. Not all users on the project must physically come to the lab; if one or more come, then all members of the group are counted in this category.

³ Users conducting the experiment remotely.

⁴ Experiments in which the sample was sent by an external PI and the experiment was conducted by in-house user support personnel in service mode. No member of the group comes to the lab, and all are counted in this category.

⁵ "Students" generally refers to graduate students, but may include a few undergraduate students.

⁶ The total of on-site users, remote users, and users sending samples will equal the total number of users.

Table 2. EMR Facility: User Affiliations, CY 2009

EMR Facility	Users	NHMFL-Affiliated Users ¹	Local Users ¹	University Users ^{2,4}	Industry Users ⁴	National Lab Users ^{3,4}
Number of Senior Investigators, U.S.	36	11	9	36	0	0
Number of Senior Investigators, non-U.S.	38	0	0	38	0	0
Number of Postdocs, U.S.	9	2	1	8	0	1
Number of Postdocs, non-U.S.	6	0	0	6	0	0
Number of Students, U.S.	24	6	9	24	0	0
Number of Students, non-U.S.	11	0	0	11	0	0
TOTAL	124	19	19	123	0	1

¹ NHMFL-Affiliated users are defined as anyone in the lab's personnel system [i.e. on our Web site/directory], even if they travel to another site.

Local users are defined as any non-NHMFL-Affiliated researchers originating at any of the institutions in proximity to the MagLab sites (i.e. researchers at FSU, UF, FAMU, or LANL), even if they travel to another site.

The sum of NHMFL-Affiliated and Local users equals what was formerly referred to as "Internal Investigators".

² In addition to external users, all users with primary affiliations at FSU, UF, or FAMU are reported in this category, even if they are also NHMFL associates.

³ In addition to external users, users with primary affiliations at NHMFL/LANL are reported in this category.

⁴ The total of university, industry, and national lab users will equal the total number of users.

Table 3. EMR Facility: Users by Discipline, CY 2009

EMR Facility	Users	Condensed Matter Physics	Chemistry, Geochemistry	Engineering	Magnets, Matls., Testing, Instrum.	Biology, Biochem., Biophys.
Number of Senior Investigators, U.S.	36	12	18	0	1	5
Number of Senior Investigators, non-U.S.	38	9	24	0	5	0
Number of Postdocs, U.S.	9	4	3	0	1	1
Number of Postdocs, non-U.S.	6	2	2	0	1	1
Number of Students, U.S.	24	6	16	0	2	0
Number of Students, non-U.S.	11	1	9	0	1	0
TOTAL	124	34	72	0	11	7

EMR Facility**By the numbers: *About our projects*****Table 4. EMR Facility:** Requests for Magnet Time, CY 2009

Requests for Magnet Time	Requests Granted	Requests Deferred/Declined
53	53	0

Table 5. EMR Facility: Research Projects¹ Profile, with magnet time in CY 2009

	Total	Minority ²	Female ³	Condensed Matter Physics	Chemistry, Geochem.	Engineering	Magnets, Matls., Testing, Instrum.	Biology, Biochem., Biophys.
Number of Projects	53	4	6	12	35	0	3	3

¹ A "project" may have associated with it a single experiment or a group of closely related experiments. A PI may have more than one project.

² The number of projects satisfying one of the following two conditions: (a) the PI is a minority OR (b) the PI is a non-minority working at a minority-serving college or university AND the project includes minority participants.

³ The number of projects satisfying one of the following two conditions: (a) the PI is a female OR (b) the PI is a male working at a college or university for women AND the project includes female participants.

EMR Facility**By the numbers: *About our magnet usage*****Table 6. EMR Facility:** Operations Statistics, CY 2009

	17T	12T	Total Days Allocated / User Affil.	Percentage Allocated / User Affil.
Number of Magnet Days¹				
NHMFL-Affiliated ²	37	68	105	14.4%
Local ²	44	41	85	11.7%
U.S. University	66	73	139	19.0%
U.S. Govt. Lab.	5	0	5	0.7%
U.S. Industry	0	0	0	0.0%
Non-U.S.	99	52	151	20.7%
Test, Calibration, Set-up, Maintenance	8	1	9	1.2%
Idle	106	130	236	32.3%
TOTAL	365	365	730	100%

¹ User Units are defined as magnet days. For the EMR Facility, one magnet day is defined as 24 hours in superconducting magnets.

² NHMFL-Affiliated users are defined as anyone in the lab's personnel system [i.e. on our Web site/directory], even if they travel to another site.

Local users are defined as any non-NHMFL-Affiliated researchers originating at any of the institutions in proximity to the MagLab sites (i.e. researchers at FSU, UF, FAMU, or LANL), even if they travel to another site.

The sum of NHMFL-Affiliated and Local usage equals what was formerly referred to as usage by "Internal Investigators".

Table 7. EMR Facility: Operations by Discipline, CY 2009

	Total Days ¹ Allocated / User Affil.	Condensed Matter Physics	Chemistry, Geochemistry	Engineering	Magnets, Matls, Testing, Instrum.	Biology, Biochem., Biophys.
NHMFL-Affiliated ²	105	18	84	0	3	0
Local ²	85	21	47	0	0	17
U.S. University	139	65	61	0	6	7
U.S. Govt. Lab.	5	0	0	0	5	0
U.S. Industry	0	0	0	0	0	0
Non-U.S.	151	99	47	0	5	0
Test, Calibration, Set-up, Maintenance	9	0	0	0	9	0
Idle	236	n/a ³	n/a	n/a	n/a	n/a
TOTAL	730	203	239	0	28	24

¹ User Units are defined as magnet days. For the EMR Facility, one magnet day is defined as 24 hours in superconducting magnets.

² NHMFL-Affiliated users are defined as anyone in the lab's personnel system [i.e. on our Web site/directory], even if they travel to another site.

Local users are defined as any non-NHMFL-Affiliated researchers originating at any of the institutions in proximity to the MagLab sites (i.e. researchers at FSU, UF, FAMU, or LANL), even if they travel to another site.

The sum of NHMFL-Affiliated and Local usage equals what was formerly referred to as usage by "Internal Investigators".

³ n/a means: not applicable

Appendix A: 2009 User Facility Statistics

Ion Cyclotron Resonance (ICR) Facility

By the numbers: *About our users*

A user is an individual or a member of a research group that is allocated magnet time. The user does not have to be "on site" for the experiment. A researcher who sends samples for analysis; a scientist who uses new lab technologies to conduct experiments remotely; or a PI who sends students to the Magnet Lab, are all considered users. All user numbers reflect distinct individuals, i.e. if a user has multiple projects (different scientific thrusts) or is allocated magnet time more than once during the year, he/she is counted only once.

Table 1. ICR Facility: User Demographics, Calendar Year 2009

ICR Facility	Users	Female	Minority ¹	On-site ^{2,6} Users	Remote Users ^{3,6}	Users Sending Sample ^{4,6}
Number of Senior Investigators, U.S.	46	4	1	23	0	23
Number of Senior Investigators, non-U.S.	3	0	3	1	1	1
Number of Postdocs, U.S.	9	1	0	8	0	1
Number of Postdocs, non-U.S.	2	0	1	1	0	1
Number of Students ⁵ , U.S.	36	13	2	23	0	13
Number of Students ⁵ , non-U.S.	3	1	2	2	0	1
TOTAL	99	19	9	58	1	40

¹ Minority status includes American Indian, Alaska Native, Black or African American, Hispanic, Native Hawaiian or other Pacific Islander. Minority status excludes Asian and White-Not of Hispanic Origin

² Users at the Magnet Lab facility operating the magnet. Not all users on the project must physically come to the lab; if one or more come, then all members of the group are counted in this category.

³ Users conducting the experiment remotely.

⁴ Experiments in which the sample was sent by an external PI and the experiment was conducted by in-house user support personnel in service mode. No member of the group comes to the lab, and all are counted in this category.

⁵ "Students" generally refers to graduate students, but may include a few undergraduate students.

⁶ The total of on-site users, remote users, and users sending samples will equal the total number of users.

Table 2. ICR Facility: User Affiliations, CY 2009

ICR Facility	Users	NHMFL-Affiliated Users ¹	Local Users ¹	University Users ^{2,4}	Industry Users ⁴	National Lab Users ^{3,4}
Number of Senior Investigators, U.S.	46	5	13	30	11	5
Number of Senior Investigators, non-U.S.	3	0	1	1	1	1
Number of Postdocs, U.S.	9	4	1	9	0	0
Number of Postdocs, non-U.S.	2	1	0	2	0	0
Number of Students, U.S.	36	11	11	31	0	5
Number of Students, non-U.S.	3	2	0	2	0	1
TOTAL	99	23	26	75	12	12

¹ NHMFL-Affiliated users are defined as anyone in the lab's personnel system [i.e. on our Web site/directory], even if they travel to another site.

Local users are defined as any non-NHMFL-Affiliated researchers originating at any of the institutions in proximity to the MagLab sites (i.e. researchers at FSU, UF, FAMU, or LANL), even if they travel to another site.

The sum of NHMFL-Affiliated and Local users equals what was formerly referred to as "Internal Investigators".

² In addition to external users, all users with primary affiliations at FSU, UF, or FAMU are reported in this category, even if they are also NHMFL associates.

³ In addition to external users, users with primary affiliations at NHMFL/LANL are reported in this category.

⁴ The total of university, industry, and national lab users will equal the total number of users.

Table 3. ICR Facility: Users by Discipline, CY 2009

ICR Facility	Users	Condensed Matter Physics	Chemistry, Geochemistry	Engineering	Magnets, Matls., Testing, Instrum.	Biology, Biochem., Biophys.
Number of Senior Investigators, U.S.	46	0	36	0	0	10
Number of Senior Investigators, non-U.S.	3	0	1	0	0	2
Number of Postdocs, U.S.	9	0	6	0	0	3
Number of Postdocs, non-U.S.	2	0	1	0	0	1
Number of Students, U.S.	36	0	20	0	0	16
Number of Students, non-U.S.	3	0	0	0	0	3
TOTAL	99	0	64	0	0	35

ICR Facility**By the numbers: *About our projects*****Table 4. ICR Facility:** Requests for Magnet Time, CY 2009

Requests for Magnet Time	Requests Granted	Requests Deferred/Declined
74	74, 100%	0,00

¹ Number of days (for all ICR magnets) that users or user's projects were allocated. Number does not include ICR research group projects.

Table 5. ICR Facility: Research Projects¹ Profile, with magnet time in CY 2009

	Total	Minority ²	Female ³	Condensed Matter Physics	Chemistry, Geochem.	Engineering	Magnets, Matls., Testing, Instrum.	Biology, Biochem., Biophys.
Number of Projects	96	9	19	0	62	0	0	34

¹ A "project" may have associated with it a single experiment or a group of closely related experiments. A PI may have more than one project.

² The number of projects satisfying one of the following two conditions: (a) the PI is a minority OR (b) the PI is a non-minority working at a minority-serving college or university AND the project includes minority participants.

³ The number of projects satisfying one of the following two conditions: (a) the PI is a female OR (b) the PI is a male working at a college or university for women AND the project includes female participants.

⁴ The total of projects in the various disciplines (Physics, Chemistry, Engineering, Mag. Matls., and Bio) will equal the total number of projects.

ICR Facility**By the numbers: *About our magnet usage*****Table 6. ICR Facility:** Operations Statistics, CY 2009

	14.5 T Hybrid ³	9.4 T Passive	Total Days Allocated / User Affil.	Percentage Allocated / User Affil.
Number of Magnet Days¹				
NHMFL-Affiliated ²	271	136	407	56%
Local ²	23	22	45	6%
U.S. University	5	33	38	5%
U.S. Govt. Lab.	7	6	13	2%
U.S. Industry	11	15	26	3%
Non-U.S.	3	0	3	<1%
Test, Calibration, Set-up, Maintenance	35	75	110	15%
Idle	10	78	88	12%
TOTAL	365	365	730	100%

1 For the ICR Facility, one magnet day is defined as 24 hours of use.

2 NHMFL-Affiliated users are defined as anyone in the lab's personnel system [i.e. on our Web site/directory], even if they travel to another site.

Local users are defined as any non-NHMFL-Affiliated researchers originating at any of the institutions in proximity to the MagLab sites (i.e. researchers at FSU, UF, FAMU, or LANL), even if they travel to another site.

The sum of NHMFL-Affiliated and Local usage equals what was formerly referred to as usage by "Internal Investigators".

3 The instrument is a hybrid between a commercial Thermo LTQ ion trap mated to an ICR in a 14.5 T superconducting magnet.

Table 7. ICR Facility: Operations by Discipline, CY 2009

	Total Days ¹ Allocated / User Affil.	Condensed Matter Physics	Chemistry, Geochem.	Engineering	Magnets, Matls, Testing, Instrum.	Biology, Biochem., Biophys.
NHMFL ²	407	0	136	0	0	271
Local ²	45	0	22	0	0	23
U.S. University	38	0	33	0	0	5
U.S. Govt. Lab.	13	0	6	0	0	7
U.S. Industry	26	0	15	0	0	11
Non-U.S.	3	0	0	0	0	3
Test, Calibration, Set-up, Maintenance	110	0	75	0	0	35
Idle	88	n/a ³	n/a	n/a	n/a	n/a
TOTAL	730	0	287	0	0	355

1 User Unites are defined as magnet days. For the ICR Facility, one magnet day is defined as 24 hours of use.

2 NHMFL-Affiliated users are defined as anyone in the lab's personnel system [i.e. on our Web site/directory], even if they travel to another site.

Local users are defined as any non-NHMFL-Affiliated researchers originating at any of the institutions in proximity to the MagLab sites (i.e. researchers at FSU, UF, FAMU, or LANL), even if they travel to another site.

The sum of NHMFL-Affiliated and Local usage equals what was formerly referred to as usage by "Internal Investigators".

Appendix A: 2009 User Facility Statistics

Geochemistry Facility

By the numbers: *About our users*

A user is an individual or a member of a research group that is allocated magnet time. The user does not have to be "on site" for the experiment. A researcher who sends samples for analysis; a scientist who uses new lab technologies to conduct experiments remotely; or a PI who sends students to the Magnet Lab, are all considered users. All user numbers reflect distinct individuals, i.e. if a user has multiple projects (different scientific thrusts) or is allocated magnet time more than once during the year, he/she is counted only once.

Table 1. Geochemistry Facility: User Demographics, Calendar Year 2009

Geochemistry Facility	Users	Female	Minority ¹	On-site ^{2,6} Users	Remote Users ^{3,6}	Users Sending Sample ^{4,6}
Number of Senior Investigators, U.S.	18	3	1	18	0	0
Number of Senior Investigators, non-U.S.	0	0	0	0	0	0
Number of Postdocs, U.S.	5	2	0	5	0	0
Number of Postdocs, non-U.S.	0	0	0	0	0	0
Number of Students ⁵ , U.S.	22	14	0	22	0	0
Number of Students ⁵ , non-U.S.	0	0	0	0	0	0
TOTAL	45	19	1	45	0	0

¹ Minority status includes American Indian, Alaska Native, Black or African American, Hispanic, Native Hawaiian or other Pacific Islander. Minority status excludes Asian and White-Not of Hispanic Origin

² Users at the Magnet Lab facility operating the magnet. Not all users on the project must physically come to the lab; if one or more come, then all members of the group are counted in this category.

³ Users conducting the experiment remotely.

⁴ Experiments in which the sample was sent by an external PI and the experiment was conducted by in-house user support personnel in service mode. No member of the group comes to the lab, and all are counted in this category.

⁵ "Students" generally refers to graduate students, but may include a few undergraduate students.

⁶ The total of on-site users, remote users, and users sending samples will equal the total number of users.

Table 2. Geochemistry Facility: User Affiliations, CY 2009

Geochemistry Facility	Users	NHMFL-Affiliated Users ¹	Local Users ¹	University Users ^{2,4}	Industry Users ⁴	National Lab Users ^{3,4}
Number of Senior Investigators, U.S.	18	9	4	16	0	2
Number of Senior Investigators, non-U.S.	0	0	0	0	0	0
Number of Postdocs, U.S.	5	5	0	5	0	0
Number of Postdocs, non-U.S.	0	0	0	0	0	0
Number of Students, U.S.	22	20	2	22	0	0
Number of Students, non-U.S.	0	0	0	0	0	0
TOTAL	45	34	6	43	0	2

¹ NHMFL-Affiliated users are defined as anyone in the lab's personnel system [i.e. on our Web site/directory], even if they travel to another site.

Local users are defined as any non-NHMFL-Affiliated researchers originating at any of the institutions in proximity to the MagLab sites (i.e. researchers at FSU, UF, FAMU, or LANL), even if they travel to another site.

The sum of NHMFL-Affiliated and Local users equals what was formerly referred to as "Internal Investigators".

² In addition to external users, all users with primary affiliations at FSU, UF, or FAMU are reported in this category, even if they are also NHMFL associates.

³ In addition to external users, users with primary affiliations at NHMFL/LANL are reported in this category.

⁴ The total of university, industry, and national lab users will equal the total number of users.

Table 3. Geochemistry Facility: Users by Discipline, CY 2009

Geochemistry Facility		Users	Condensed Matter Physics	Chemistry, Geochemistry	Engineering	Magnets, Matls., Testing, Instrum.	Biology, Biochem., Biophys.
Number of Senior Investigators, U.S.	18	0	18	0	0	0	
Number of Senior Investigators, non-U.S.	0	0	0	0	0	0	
Number of Postdocs, U.S.	5	0	5	0	0	0	
Number of Postdocs, non-U.S.	0	0	0	0	0	0	
Number of Students, U.S.	22	0	22	0	0	0	
Number of Students, non-U.S.	0	0	0	0	0	0	
TOTAL	45	0	45	0	0	0	

Geochemistry Facility

By the numbers: *About our projects*

Table 4. Geochemistry Facility: Requests for Magnet Time, CY 2009

Requests for Magnet Time	Requests Granted	Requests Deferred/Declined
19	19	0

Table 5. Geochemistry Facility: Research Projects¹ Profile, with magnet time in CY 2009

	Total	Minority ²	Female ³	Condensed Matter Physics	Chemistry, Geochem.	Engineering	Magnets, Matls., Testing, Instrum.	Biology, Biochem., Biophys.
Number of Projects	19	1	10	0	19	0	0	0

¹ A "project" may have associated with it a single experiment or a group of closely related experiments. A PI may have more than one project.

² The number of projects satisfying one of the following two conditions: (a) the PI is a minority OR (b) the PI is a non-minority working at a minority-serving college or university AND the project includes minority participants.

³ The number of projects satisfying one of the following two conditions: (a) the PI is a female OR (b) the PI is a male working at a college or university for women AND the project includes female participants.

Geochemistry Facility**By the numbers: *About our magnet usage*****Table 6. Geochemistry Facility: Operations Statistics, CY 2009**

	262/RPQ	MC-ICP-MS Neptune	ELEMENT	Delta XP	Total Days Allocated / User Affil.	Percentage Allocated / User Affil.
Number of Magnet Days¹						
NHMFL-Affiliated ²	30	180	60	180	450	46%
Local ²	0	0	30	20	50	5%
U.S. University	0	0	0	0	0	0
U.S. Govt. Lab.	15	15	20	0	50	5%
U.S. Industry	0	0	0	0	0	0
Non-U.S.	0	0	0	0	0	0
Test, Calibration, Set-up, Maintenance	10	40	120	30	200	21%
Idle	187	7	12	12	218	23%
TOTAL	242	242	242	242	968	100%

1 User Units are defined as magnet days. For the Geochemistry Facility, one magnet day is defined as 12 hours on the instrument.

2 NHMFL-Affiliated users are defined as anyone in the lab's personnel system [i.e. on our Web site/directory], even if they travel to another site.

Local users are defined as any non-NHMFL-Affiliated researchers originating at any of the institutions in proximity to the MagLab sites (i.e. researchers at FSU, UF, FAMU, or LANL), even if they travel to another site.

The sum of NHMFL-Affiliated and Local usage equals what was formerly referred to as usage by "Internal Investigators".

Table 7. Geochemistry Facility: Operations by Discipline, CY 2009

	Total Days ¹ Allocated / User Affil.	Condensed Matter Physics	Chemistry, Geochem.	Engineering	Magnets, Matls, Testing, Instrum.	Biology, Biochem., Biophys.
NHMFL-Affiliated ²	450	0	450	0	0	0
Local ²	50	0	50	0	0	0
U.S. University	0	0	0	0	0	0
U.S. Govt. Lab.	50	0	50	0	0	0
U.S. Industry	0	0	0	0	0	0
Non-U.S.	0	0	0	0	0	0
Test, Calibration, Set-up, Maintenance	200	0	200	0	0	0
Idle	218	n/a ³	n/a	n/a	n/a	n/a
TOTAL	968	0	750	0	0	0

1 User Units are defined as magnet days. For the Geochemistry Facility, one magnet day is defined as 12 hours on the instrument.

2 NHMFL-Affiliated users are defined as anyone in the lab's personnel system [i.e. on our Web site/directory], even if they travel to another site.

Local users are defined as any non-NHMFL-Affiliated researchers originating at any of the institutions in proximity to the MagLab sites (i.e. researchers at FSU, UF, FAMU, or LANL), even if they travel to another site.

The sum of NHMFL-Affiliated and Local usage equals what was formerly referred to as usage by "Internal Investigators".

3 n/a means: not applicable

Appendix B: Research Reports by Category

At the end of each year, Magnet Lab users and faculty at FSU, UF, and LANL submit brief abstracts of their experiments, research, and scholarly endeavors. In 2009, 416 research reports were approved and all are published online

<http://www.magnet.fsu.edu/usershub/publications/researchreportsonline.aspx>.

The reports are searchable by facility, category, first author, PI, and keywords.

Biochemistry – 51 Reports

Facility	PI Name, Affiliation	Report Title
AMRIS	Best, MD, U. Tennessee, Chemistry	Characterization of the Biophysical Properties of Novel Saturated Bis(monoacylglycero)phosphate Analogues
AMRIS	Blackband, S.J., UF, Neuroscience	¹³ C-Glycine Metabolism in a Rat Fibrosarcoma Monitored by <i>In Vivo</i> ¹³ C Spectroscopy
AMRIS	Conlon, T.C., Powell Gene Therapy Center	Modified Skeletal Myoblast Therapy for Cardiac Failure Using AAV SDF1 in Rattus and Porcine Models
AMRIS	Dossey, A.T., UF, Biochemistry and Molecular Biology	Compound Discovery and Biosynthesis in Walkingstick Insects (Order Phasmatodea)
AMRIS	Edison, A.S., UF	Identification of an Oxidizer from Burkholderia cenocepacia
AMRIS	Fanucci, G.E., UF, Chemistry	Solute-Protein Interactions Probed Using ¹⁵ N-HSQC NMR
AMRIS	Fanucci, G.E., UF, Chemistry	Structure Determination of HIV-1 Protease-Inhibitors Based on ¹ H NMR Chemical Shifts
AMRIS	Fanucci, G.E., UF, Chemistry	The Effect of Bis(monoacylglycero)phosphate on the Thermotropic Phase Behavior of DPPC
AMRIS	Fanucci, G.E., UF, Chemistry	2D ¹ H- ¹⁵ N HSQC Spectrum of Sap-B
AMRIS	Huisden, C.M., ADEK U., Naturopathic Medicine	Anticancer Drug Discovery and Development in Suriname; Studies on Surinamese Medicinal Plants with Antiproliferative and/or Angiosuppressive Characteristics by the Research Group Medicinal Plants
AMRIS	Long, J.R., UF, Biochemistry & Molecular Biology	Partitioning, Dynamics, and Orientation of Lung Surfactant Peptide KL4 in Phospholipid Bilayers
AMRIS	Long, J.R., UF, Biochemistry & Molecular Biology	Solid State ² H and ³¹ P NMR Characterization of Lung Surfactant Preparations
AMRIS	Montie, E.W., U. South Florida, College of Marine Science	Determining the Effects of Thyroid Hormone Disruption on Brain Development in Rats Using Magnetic Resonance Imaging <i>In Vivo</i> at 11 T and in Excised Brains at 17.6 T
AMRIS	Simmerling, C., SUNY-Stony Brook, Chemistry	Effects of Subtype Polymorphisms on HIV-1 Protease Inhibitor Interactions
AMRIS	Vasenkov, S., UF	Observation of Time-dependent Diffusion Behavior of Lipids in Model Lipid Membranes Using Pulsed Field Gradient NMR with High Gradient Strength
AMRIS	Walter, G.A., UF, Physiology	γ -Sarcoglycan Deficiency Reduces Left Ventricular Function and T2 in Old Mice
AMRIS	Weiss, D., UF	Use of Neuroimaging in Regenerative Medicine
EMR	Bowman, M.K., U. Alabama, Chemistry	High-Field EMR Studies of Rapid Freeze Quenched Radical in Proteins
EMR	Britt, R. D., UC, Davis, Department of Chemistry	The Structure of the Tetrahydrobiopterin Radical Intermediate in Nitric Oxide Synthase
ICR	Blanchard, J.S., Albert Einstein College of Medicine, Biochemistry	Mapping of the Allosteric Network in the Regulation of α -Isopropylmalate Synthase from Mycobacterium tuberculosis by the Feedback Inhibitor L-Leucine: Solution-Phase H/D Exchange Monitored by FT-ICR Mass Spectrometry

RESEARCH REPORTS BY CATEGORY

Facility	PI Name, Affiliation	Report Title
ICR	Fannuci, G.E., UF, Chemistry	Sequential Proteolysis and High-Field FT-ICR MS to Determine Disulfide Connectivity and 4-Maleimide TEMPO Spin-Label Location in L126C GM2 Activator Protein
ICR	Gajiwala, K.S., Pfizer	KIT Kinase Mutants Show Novel Mechanisms of Drug Resistance to Imatinib and Sunitinib in Gastrointestinal Stromal Tumor Patients
ICR	Kelleher, N.L., U. Illinois	A Robust 2-Dimensional Separation for Top-Down Tandem Mass Spectrometry of the Low Mass Proteome
ICR	Li, L., U. Wisconsin, Pharmacy and Chemistry	Combining Bottom-Up and Top-Down Mass Spectrometric Strategies for De Novo Sequencing of the Crustacean Hyperglycemic Hormone (CHH) from <i>Cancer borealis</i>
ICR	Tsybin, Y.O., EPFL, Chemistry	Periodic Sequence Distribution of Product Ion Abundances in Electron Capture Dissociation of Amphipathic Peptides and Proteins
NMR	Brüschweiler, R., FSU, Chemistry and Biochemistry	Toward a Model of the Solution Structure of Arginine Kinase by Combining NMR and X-ray Crystallography
NMR	Brüschweiler, R., FSU, Chemistry and Biochemistry	Conformational Exchange of CBD2 in its Apo, Ca ²⁺ -Bound and Substoichiometric States
NMR	Brüschweiler, R., FSU, Chemistry and Biochemistry	A Dictionary for Protein Side-Chain Entropies from NMR Order Parameters
NMR	Brüschweiler, R., FSU, Department of Chemistry and Biochemistry	Interdomain Dynamics in the Na ⁺ Ca ²⁺ Exchanger
NMR	Busath, D.D., Brigham Young U.	Channel Gating: Gramicidin A, A Model for Other Ion Channels
NMR	Busath, D.D., Brigham Young U., Physiology & Developmental Biology	Influenza A M2 Protein: A Transporter or a Channel?
NMR	Cotten, M., Hamilton College, Chemistry	High-Resolution Structural Studies of Amphipathic Piscidin in Aligned Lipid Bilayers
NMR	Cotten, M., Hamilton College, Chemistry	Enhanced Spectral Resolution of an Antimicrobial Peptide in Aligned Bilayers at 900 MHz
NMR	Cross, T.A., FSU, Chemistry and Biochemistry & NHMFL	Mycobacterial Cell Wall Proteins: Expression, Purification and Function
NMR	Cross, T.A., FSU, Chemistry and Biochemistry & NHMFL	Stability and Application of ¹ H Amide Chemical Shift Tensors for Structural Restraints
NMR	Cross, T.A., FSU, Chemistry and Biochemistry & NHMFL	LpqH is the Enzymatic Target for LspA, a Drug Target for M. Tuberculosis
NMR	Cross, T.A., FSU, Chemistry and Biochemistry & NHMFL	The Importance of a Lipid Bilayer Environment for Membrane Proteins
NMR	Cross, T.A., FSU, Chemistry and Biochemistry & NHMFL	Is MgtC, a Potential Drug Target in M. tuberculosis, Inhibited by MgtR
NMR	Cross, T.A., FSU, Chemistry and Biochemistry & NHMFL	Mutating the M2 Protein for Structural and Functional Insights
NMR	Cross, T.A., FSU, Chemistry and Biochemistry & NHMFL	Sample Preparation for MAS and PISEMA Spectroscopy of M2 Protein
NMR	Cross, TA, FSU, Chemistry and Biochemistry	High Resolution NMR structure of M2 Proton Channel from Influenza A Virus in Liquid Crystalline Lipid Bilayer
NMR	Eisenmesser, E.Z., U. Colorado Denver, Biochemistry & Mol. Gen.	The Extracellular Region of CD147 Does Not Self-associate in the Absence of Another Mediator
NMR	Grant, S.C., NHMFL - FSU, Chemical and Biomedical Engineering	Intracellular Bimodal Nanoparticles Based on Quantum Dots for High Field MRI at 21.1 T
NMR	Harris, T.K., U. Miami, School of Medicine, Biochemistry and Molecular Biology	Backbone Chemical Shift Assignments of the Pleckstrin Homology Domain of Phosphoinositide-Dependent Protein Kinase-1 (PDK1)

Facility	PI Name, Affiliation	Report Title
NMR	Kern, D., Brandeis U., Biophysics	The Dynamics of Y101 in NtrC ^R
NMR	Morris, M.D., U. Michigan, Chemistry	Probing the Structure of Calcium Sites in Bone Mineral by ⁴³ Ca Solid-State NMR Spectroscopy
NMR	Null, B, Stanford U., Biochemistry	High-Resolution, <i>In Vivo</i> Magnetic Resonance Imaging of <i>Drosophila</i> at 21.1 T
NMR	Paravastu, A.K., FAMU-FSU College of Engineering, Chemical and Biomedical Engineering	Solid State NMR Structural Characterization of Nonfibrillar Aggregates of the Alzheimer's beta-amyloid Peptide
NMR	Paravastu, A.K., FAMU-FSU College of Engineering, Chemical and Biomedical Engineering	Solid State NMR Analysis of Designer Self-Assembling Peptides
NMR	Smirnov, S.L., Western Washington U., Chemistry	Structural Characterization of D6-HP, a Villin Fragment Capable of Bundling of F-actin
NMR	Zhou, H.X., FSU, Physics	A Mechanistic Model for M2 Proton Conductance

Biology – 28 Reports

Facility	PI Name, Affiliation	Report Title
AMRIS	Benveniste, H., Stonybrook U.	A Magnetic Resonance Microscopy Neurological Atlas (MRM-NeAt)
AMRIS	Blackband, S.J., UF	MR Microscopy of Nerve Fiber Structure at the Cellular Level; Validation of Tractography
AMRIS	Blackband, S.J., UF, Neuroscience	MR Microscopy of Human Neurons with Direct Histological Correlation
AMRIS	Bolch, W.E., Advanced Laboratory for Radiation Dosimetry Studies (ALRADs), UF Department of Nuclear & Radiological Engineering	Construction of a Specimen-specific 10.4 Week Hybrid Fetal Phantom
AMRIS	Collingwood, J.F., U. Warwick	Quantitative MRI Microscopy of the Basal Ganglia and Pons
AMRIS	Edison, A.S., UF, Biochemistry & Molecular Biology	Metabolomics of <i>Caenorhabditis elegans</i>
AMRIS	Edison, A.S., UF, Biochemistry & Molecular Biology	Identification and Characterization of Nematode Pheromones
AMRIS	Guay-Woodford, L., U. Alabama, Nephrology	MRM of the Microstructure of Isolated Kidney Tissue
AMRIS	Isaza, R., UF, College of Veterinary Medicine, Small Animal Clinical Sciences	Anatomy of the Asian Elephant (<i>Elephas maximus</i>) Front Foot: Anatomical Description, Imaging, Interpretation, and Clinical Relevance
AMRIS	Kaan, E., UF	Discourse Processing in the Brain: Setting Up New Discourse Referents
AMRIS	Sambanis, A., Georgia Institute of Technology, School of Chemical & Biomolecular Engineering	Noninvasive Monitoring of the Oxygen Availability within Tissue Engineered Substitutes
AMRIS	Turner, B.L., Smithsonian Tropical Research Institute	Sources and Stability of Biogenic Phosphorus in Freshwater Wetlands
AMRIS	Turner, B.L., Smithsonian Tropical Research Institute	Characterization of Carbon in Leaf Litter, Water Extracts of Leaf Litter, and Soil Solution in a Lowland Tropical Forest Using ¹³ C and ¹ H NMR Spectroscopy
AMRIS	Vandenborne, K., UF, Physical Therapy	Effect of Viral Mediated Overexpression of Insulin Like Growth Factor (IGF-I) on Skeletal Muscle Size and Damage using Magnetic Resonance Imaging
AMRIS	Walter, G.A., UF, Physiology	Imaging of Tissue Damage in Dystrophic Muscle
AMRIS	Walter, G.A., UF, physiology	A Genetic Reporter System for MRI Based on LacZ Expression

Facility	PI, Affiliation	Report Title
NMR	Artemov, D., Johns Hopkins U., School of Medicine, Radiology	MR Pharmacoangiography-Vascular Modulation of Delivery
NMR	Campbell, S.C., The FSU, Nutrition, Food & Exercise Sciences	Syrian Hamster Model of Postmenopausal Atherosclerosis as Assessed by Vascular MRI at 21.1 T
NMR	Grant, S.C., FSU, CIMAR	Contrast Enhancement in Preserved Tissue Utilizing Low Temperatures at High Magnetic Fields
NMR	Grant, S.C., FSU, CIMAR	A Pilot Study: High Resolution 1H MRI and MRS of the Adult Zebra Finch
NMR	Grant, S.C., NHMFL, CIMAR	Diffusion Tensor Imaging to Track Changes in Skeletal Muscle Architecture of Sarcopenic Rats
NMR	Grant, S.C., FSU / NHMFL, Chemical and Biomedical Engineering	High Magnetic Field Efficiency of Intracellular SPIO: A comparison between 11.75 and 21.1T
NMR	Haupt, T.A., FSU, Biological Science	Rats Show a Reflexive Head Tilt during Exposure to a 14 T Static Magnetic Field
NMR	Kim, J.-S., FSU, NFES	Effects of Resistance Training and HMB on Muscle Fiber CSA and Body Mass in Aged Rats: A DTI and DEXA Study
NMR	Schepkin, V. D., NHMFL/FSU, CIMAR	Intracellular Sodium and Apoptosis, <i>In Vivo</i> MRI of Rodent Glioma Therapy at 21.1 T
NMR	Schepkin, V., NHMFL, CIMAR	<i>In vivo</i> Sodium and Proton MR Imaging of Large Rodents at 21.1 T
NMR	Schweitzer, K.J., Mayo Clinic Florida, Neurology	High Resolution 1H MRI of Postmortem Human Brain Sections Performed at 21.1 T
NMR	Schweitzer, K.J., Mayo Clinic Florida, Neurology	A Novel Approach to Dementia: High Resolution 1H MRI of the Human Hippocampus at 21.1 T

Chemistry – 55 Reports

Facility	PI, Affiliation	Report Title
AMRIS	Castro-Gamboa, ICG, IQ-UNESP-CAR, Organic Chemistry	Dereplication of Brazilian Plants from Cerrado and Atlantic Forest Using Hyphenated Techniques and NMR
AMRIS	Dossey, A.T., UF, Biochemistry and Molecular Biology	Continued Discovery of Defensive Chemistry in Walkingstick Insects (Order Phasmatodea)
AMRIS	Hamilton, T.D., Barry U., Physical Sciences	¹ H and ¹³ C NMR Characterization of Porphyrins Made by Traditional and Solvent-free Synthesis
AMRIS	Long, J.R., UF, BMB	Monitoring Chemical Shifts and Diffusion in Calcium Carbonate Solutions: Understanding the Mechanisms Underlying Biomineralization
AMRIS	Luesch, H., UF	Exploiting Marine Cyanobacteria for Drug Discovery
AMRIS	Talham, D.R., UF, Chemistry	Surface Modified Gadolinium Phosphate and Nanoparticles as MRI Contrast Agent
Applied Superconductivity Center	Latturmer, S.E., FSU, Chemistry	Ruthenium Intermetallics Grown from La-Ni Flux: Synthesis, Structure, and Physical Properties
DC Field	Long, J.R., UC Berkeley	High-Field EPR Study of the Magnetic Molecular Building Unit [ReCl ₄ (CN) ₂] ²⁻
DC Field	Rupnik, K., Louisiana State U., Chemistry	Polarization Phase Selective Spectroscopy (PPS) Investigations
DC Field	Telser, J., Roosevelt U., Chemistry	HFEPR Studies of High-Oxidation State Iron Complexes with Highly Charged Chelating Ligands
EMR	Aitken, J., Duquesne U., Department of Chemistry and Biochemistry	High-Frequency EPR Characterization of Mn-substituted CuInSe ₂ Chalcopyrites

Facility	PI, Affiliation	Report Title
EMR	Angerhofer, A., UF, Department of Chemistry	Electron Spin Echo Envelop Modulation (ESEEM) of the Mn-Triethylenetetramine Complex
EMR	Berry, J., U. Wisconsin - Madison	High-Frequency EPR Studies on the Cr-Cr-Mn and Mo-Mo-Mn Linear Triatomic Chains
EMR	Dalal, N.S., FSU, Chemistry	Unexpected Splitting of the EPR Spectrum of a Simple $S=1/2$ System: K_3CrO_8
EMR	Dinse, K.-P., FU Berlin, Physics	Prospects of High-Frequency EPR in Heterogenous Catalysis
EMR	Hendrickson, D.N., UC San Diego, Chemistry	Relieving Frustration in an Antiferromagnetic Triangular Mn_3 Complex
EMR	Holder, A.A., U. Southern Mississippi, Chemistry and Biochemistry	Studies on the Mechanism of Reduction of Vanadium (V) Dipicolinate Compounds by L-Ascorbic Acid: The <i>Ascidia nigra</i> story
EMR	Jeziarska, J., Wroclaw U., Chemistry	Solvent Effect on EPR, Molecular and Electronic Properties of Semiquinone Radical Derived from 3,4-dihydroxybenzoic Acid as Model for Humic Acid Transient Radicals: High-Field EPR and DFT Studies
EMR	Julve, M., U. Valencia, Spain, Institute of Molecular Science	HFEPR Experiments on Tri-nuclear Clusters $Re^{IV}_2M^{II}$ ($M^{II} = Mn, Co, Cu$)
EMR	Kojima, M., Okayama U., Chemistry	Synthesis and Properties of Manganese(III) Complexes with a Tripodal Ligand
EMR	Kokozay, V. N., National Taras Shevchenko U., Chemistry	High-Field EPR and Magnetic Studies on Cr-Cr Interactions in New Heterometallic Tetranuclear Complexes
EMR	Kokozay, V.N., National Taras Shevchenko U., Chemistry	Direct Synthesis, Crystal Structure, High-Field EPR and Magnetic Studies on an Octanuclear Heterometallic Cu(II)/Cd(II) Complex of Triethanolamine
EMR	Kroto, H.W., FSU, Chemistry	High Frequency EPR Detection of Order-Disorder Antiferromagnetic Phase Transition in a Metal-Organic Framework (MOF) with the Perovskite ABX ₃ Architecture
EMR	Krzystek, J., NHMFL	High-Frequency and -Field EPR of Monomeric Complexes of Rhenium(IV)
EMR	Krzystek, J., NHMFL	EPR Studies of Catalytically Relevant Four-Coordinate Cobalt(I) Complexes
EMR	Kyritsis, P., U. Athens, Greece, Chemistry	HFEPR Investigation of the Electronic Properties of $S = 1$ Tetrahedral and Octahedral Ni(II) Complexes Containing the Imidodiphosphate Family of Ligands
EMR	Long, J.R., UC Berkeley, Chemistry	Determination of Zero-Field Splitting Parameters for a Series of High-Spin Iron(II) Complexes Using High-Field EPR
EMR	Mindiola, D.A., Indiana U. - Bloomington	HFEPR Studies of Organovanadium(III) Complexes with Relevance to Catalytic Processes
EMR	Murillo, C. A., Texas A&M U., Department of Chemistry	Proof by EPR Spectroscopy that the Unpaired Electron in an $[Os_2]^{7+}$ Species is in a δ^* Metal-based Molecular Orbital
EMR	Neves, A., Universidade Federal de Santa Catarina, Florianópolis-SC, Brazil, Chemistry	HFEPR Studies on Dinuclear Complexes Relevant to Purple Acid Phosphatase (PAP) Enzymes
EMR	Ozarowski, A, FSU, NHMFL	Investigation of the 'Spin Crossover' Transition and Light-Induced Excited Spin State Trapping (LIESST) by Mössbauer Spectroscopy
EMR	Powell, A.K., Universität Karlsruhe, Institut für Anorganische Chemie	High Frequency EPR Characterization of the Single-Molecule Magnet $\{Fe_2Dy_4\}$
EMR	Raptis, R., U. Puerto Rico, Chemistry	EPR Studies of Trinuclear Pyrazolate-Bridged Cu(II) Clusters with Unusual Magnetic Properties
EMR	Shatruk, M., FSU, Department of Chemistry and Biochemistry	High-frequency Single-crystal EPR Measurements on $MnPc(py)_2$ Complex

Facility	PI, Affiliation	Report Title
EMR	Szymanska, I. B., Nicolaus Copernicus U., Chemistry	High-Field EPR and Magnetic Susceptibility Studies on Tetranuclear Ferromagnetic Quinoline Adducts of Copper(II) Trifluoroacetate
EMR	Telser, J, Roosevelt U., Biological, Chemical & Physical Sciences	HFEPR Studies of Trigonally Distorted Octahedral Ni(II) with a Macrocyclic Amine Ligand
EMR	Yang, E.-C., Fu Jen Catholic U., Taiwan, Chemistry	HFEPR Studies of an Octanuclear Manganese Single-Molecule Magnet
Geochemistry	Latturner, S.E., FSU, Chemistry	Transition Metal Ion Exchange Using Poly(ethylene glycol) Oligomers as Solvents
ICR	Headley, J.V., Water Science and Technology Directorate, Saskatoon, Saskatchewan, Canada	Aquatic Plant Derived Changes in Oil Sands Naphthenic Acid Signatures Determined by Low, High and Ultra-High Resolution Mass Spectrometry
ICR	Hockaday, W.C., Rice U., Earth Sciences	Electrospray and Photoionization Mass Spectrometry for the Characterization of Organic Matter in Natural Waters: A Qualitative Assessment
ICR	Mullins, O.C., Schlumberger	Nanoaggregates of Asphaltenes in a Reservoir Crude Oil and Reservoir Connectivity
ICR	Rahimi, P, Nationcentre for Upgrading Technology, Alberta, Canada	Effect of Thermal Treatment on Acidic Organic Species from Athabasca Bitumen Heavy Vacuum Gas Oil, Analyzed by Negative-Ion Electrospray FT-ICR Mass Spectrometry
ICR	Rodgers, R.P., FSU, NHMFL, Chemistry	Identification of Vanadyl Porphyrins in a Heavy Crude Oil and Raw Asphaltene by Atmospheric Pressure Photoionization FT-ICR Mass Spectrometry
ICR	Russell, D.H., Texas A & M U., Chemistry	Petroleum Crude Oil Characterization by Ion Mobility and FT-ICR Mass Spectrometry
ICR	Schafer, M., U. Cologne, Germany, Chemistry	Kinetic Determination of Potassium Affinities by IRMPD: Elucidation of Precursor Ion Structures
ICR	Yen, A.T, Baker Hughes, Sugar Land, TX	Chemical Speciation of Calcium and Sodium Naphthenate Deposits by Electrospray Ionization FT-ICR Mass Spectrometry
NMR	Brüschweiler, R., NHMFL	Ultra-High Resolution Carbon-Carbon Connectivities by Doubly Indirect Covariance NMR
NMR	Grey, C.P., State U. New York and U. Cambridge, Chemistry	⁴⁵ Sc Solid State NMR Studies of Sc Doped Barium Zirconate Anionic Conductors
NMR	Grey, C.P., Stony Brook U., Chemistry	⁸⁹ Y Solid State NMR Studies of Y Doped Barium Zirconate and Barium Stannate Anionic Conductors
NMR	Hernandez-Maldonado, A.J., U. Puerto Rico - Mayaguez, Department of Chemical Engineering	MAS NMR Characterization of Sr ²⁺ -SAPO-34 for CO ₂ Adsorption
NMR	Jakobsen, H., Aarhus U., Chemistry, Hans Jørgen Jakobsen	Natural Abundance ³³ S Solid-State NMR of Disordered [(C ₂ H ₅) ₄ N][ReS ₄]. A Strategy for Acquisition and Analysis of Complex ³³ S Solid-State NMR Spectra
NMR	Le Pollès, L., Ecole Nationale Supérieure de Chimie de Rennes, Matériaux inorganiques : Chimie douce et réactivité	⁹⁵ Mo NMR Study of Diluted and Disordered Molybdenum Cluster Compounds
NMR	Schurko, R.W., Prof., U. Windsor	Solid-State ³⁵ Cl NMR Spectroscopy of a Variety of Hydrochloride Pharmaceuticals
NMR	Scott, S., UCSB, Chemical Engineering	²⁵ Mg MAS NMR Study of a Ziegler-Natta Catalyst Support
Pulsed Field	Kaner, R.B., UCLA, Department of Chemistry	Full Elastic Tensor of a Crystal of the Superhard Compound ReB ₂

Engineering Materials – 9 Reports

Facility	PI, Affiliation	Report Title
DC Field	Bunting, B., Oak Ridge National Laboratory	Magnetic Treatment of Steel Parts with High Retained Austenite
DC Field	Molodov, D.M., RWTH Aachen U., Institute of Physical Metallurgy and Metal Physics	<i>In-situ</i> Measurements of Magnetically Driven Motion of Specific Individual Grain Boundaries in Zn with a High Field Magnet Microscopy Probe
DC Field	Walsh, R.P., NHMFL	Mechanical Properties of Modified JK2LB for Nb ₃ Sn CICC Applications
EMR	Eichel, R.A., U. Freiburg, Physical Chemistry	High-frequency EPR Characterization of Functional Centers in Ferrocic Ceramics
AMRIS	Vasenkov, S., UF	Sorbate Diffusion on Different Length Scales in SBA-15 Porous Solids: Combined Application of Pulsed Field Gradient NMR and Tracer Zero Length Column Technique
MS & T	Han, K., NHMFL	Grain Boundary Precipitates on Cryogenic Properties of Aged 316-Type Stainless Steels
NMR	Schepkin, V.D., NHMFL/FSU, CIMAR	MRI Evaluation of Adsorbed Water in Solids at 21.1 T
Pulsed Field	Dogan, O.N., National Energy Technology Lab	Elastic Properties of Chromium Alloys
Pulsed Field	Farinholt, K.M., LANL, Engineering Institute	Understanding Strain Sensors at Liquid Nitrogen Temperatures

Geochemistry – 17 Reports

Facility	PI, Affiliation	Report Title
EMR	Jeziarska, J., Wroclaw U., Chemistry	Influence of Pb(II) Ions on the EPR Properties of the Semiquinone Radicals of Humic Acids and Model Compounds: High Field EPR and Relativistic DFT Studies
Geochemistry	Chanton, J.P., Department of Oceanography, FSU	C And H Sources To Methane Production Associated With Permafrost Degradation
Geochemistry	Du, X., Geochemistry, Geological Sciences, FSU	Can Submarine Groundwater Discharge Be a Major Source of Mercury Input to North Gulf of Mexico?
Geochemistry	Froelich, P. N., NHMFL, FSU, Oceanography, FSU	Cave Air Ventilation and CO ₂ Outgassing by Radon-222 Modelling: How Fast Do Caves Breathe?
Geochemistry	Froelich, P.N., NHMFL, FSU, Oceanography	Lithium Isotope Ratios in Marine Forams - A Proxy for the Geologic Evolution of Seawater Chemistry Through the Cenozoic
Geochemistry	Froelich, P.N., NHMFL, FSU, Oceanography	Determination of Arsenic and Selenium in Chloro-matrix Rainwater Collected near a CFPP by Quadrupole ICP-MS with an Octopole Reaction System
Geochemistry	Humayun, M., FSU, Geological Sciences & NHMFL Geochemistry	Major Element Analysis of Natural Silicates by Laser Ablation Magnetic Sector-Field ICP-MS
Geochemistry	Humayun, M., FSU, Geological Sciences & NHMFL Geochemistry	Tungsten Isotopic Compositions of Phosphates from Meteorites: Melting in the Early Solar System
Geochemistry	Humayun, M., FSU, Geological Sciences & NHMFL Geochemistry	<i>In Situ</i> Determination of Siderophile Elements in Metals from Enstatite Achondrites
Geochemistry	Landing, W.M., FSU, Oceanography	Trace Element Analysis of Rainfall Samples from the Pensacola Airshed
Geochemistry	Landing, WM, FSU, Oceanography	Determination of Mn, Fe, Co, Ni, Cu, Zn, Cd and Pb in Seawater Using High Resolution Magnetic Sector Inductively Coupled Mass Spectrometry (HR-ICPMS)

Facility	PI, Affiliation	Report Title
Geochemistry	Salters, V.J.M., NHMFL-FSU, Geology	The Oxygen Fugacity Structure of the Lithosphere/Upper Asthenosphere Beneath Hawai'i
Geochemistry	Salters, V.J.M., Geochemistry, Geochemistry	Nb/Ta - Zr/Hf Fractionations during Subduction: Implications for the "Missing" Nb
Geochemistry	Salters, V.J.M., NHMFL, Geological Sciences	Patterns of Melt Migration at the East Pacific Rise
Geochemistry	Salters, V.J.M., NHMFL, Geological Sciences	Geochemical and Isotopic Evidence for Differentiation and Assimilation of in the Origin of Mount Rainier's Calc-Alkaline Andesitic Suite
Geochemistry	Wang, Y., NHMFL, Geological Sciences	Chemical and Carbon Isotopic Characteristics of Ash and Smoke Derived from Burning of C3 and C4 Grasses
Geochemistry	Wang, Y., NHMFL, Geological Sciences	Isotopic Evidence for the Source and Fate of Phosphorus in Everglades Wetland Ecosystems

Instrumentation – 15 Reports

Facility	PI, Affiliation	Report Title
DC Field	Koyama, K., Tohoku U., Institute for Materials Research	High Field Differential Thermal Analysis in 45T
DC Field	McGill, S.A., NHMFL	High-Magnetic Field Magneto-Optical Kerr Spectroscopy of BaCuSi ₂ O ₆
DC Field	Suslov, A., NHMFL-FSU	Stand Alone Experimental Setup for DC Transport Measurements
DC Field	Tozer, S.W., NHMFL	High Resolution Miniature Dilatometer Based on AFM Piezocantilever
ICR	Emmett, M.R., FSU, NHMFL, Chemistry	Fast Reversed-Phase Liquid Chromatography to Reduce Back Exchange and Increase Throughput in H/D Exchange Monitored by FT-ICR Mass Spectrometry
ICR	Kim, S., Korea Basic Science Institute	Automated Electrospray Ionization FT-ICR Mass Spectrometry for Petroleum Analysis
ICR	Kostiainen, R., U. Helsinki	Microchip Atmospheric Pressure Photoionization for Analysis of Petroleum by FT-ICR Mass Spectrometry
NMR	Gor'kov, P.L., NHMFL	Efficient Double-resonance Coil for Low-gamma MRI of Large Rodent Brains at 21.1 Tesla
NMR	Grant, S.C., NHMFL, CIMAR	Design of a ¹ H / ³¹ P RF Switchable Surface Coil for <i>in vivo</i> Spectroscopy and Imaging at 11.75 T
Pulsed Field	Boebinger, G.S., NHMFL/FSU	Calibration of a Custom Built Cernox Thermometer in Pulsed Magnetic Fields
Pulsed Field	Boebinger, G.S., NHMFL/FSU	Calibration of a Custom Built Cernox Thermometer with 4 Wires in a Pulsed Magnetic Field
Pulsed Field	Jaime, M., LANL, NHMFL	Test of New Technique for Seebeck Measurement
Pulsed Field	Maiorov, B., LANL, MPA-STC	Test/Calibration of Rotator Probe for DC Magnetic Fields
Pulsed Field	Suzuki, Y., NHMFL-LANL	Interface Characterization for 2-omega Method for Thermal Conductivity Measurement in a Pulsed Magnetic Field
Pulsed Field	Weickert, D.F., MPI CPFS, Dresden, Germany	Thermometry for Thermal Properties Measurements in High Fields

Kondo/Heavy Fermion Systems – 10 Reports

Facility	PI, Affiliation	Report Title
DC Field	Andraka, B., UF	Search for Heavy Quasiparticles in the Resistivity of $\text{PrOs}_4\text{Sb}_{12}$ in Magnetic Fields: Comparison with $\text{Pr}_{0.7}\text{La}_{0.3}\text{Os}_4\text{Sb}_{12}$
DC Field	Geibel, C., Max Planck, Dresden	First Potential Signs of 'Itinerant' f-Electron Physics in the Heavy Fermion System YbRh_2Si_2
DC Field	Goodrich, R.G., George Washington U., Department of Physics	Quantum Oscillations in Pnictides and 1-1-5's
DC Field	McGill, S.A., NHMFL	Terahertz Time-Domain Magneto-Spectroscopy of $\text{BaCuSi}_2\text{O}_6$ and CeCoIn_5
DC Field	Tozer, S.W., NHMFL	Hall Measurement of CeIn_3 at High Pressure
DC Field	Urbano, R.R., NHMFL	Hole-doping Effects in CeIn_3 : A Nuclear Quadrupole Resonance (NQR) Investigation
DC Field	Weickert, FW, MPI CPFS	High Field Cp(T,H) as a Probe for Strongly Correlated Electrons: Testing the Energy Gap in CeRu_4Sn_6
Pulsed Field	Canfield, P.C., Ames Laboratory, U.S. DOE and Iowa State U., Department of Physics and Astronomy	Low Temperature Heat Capacity in Applied Magnetic Field of Model, Yb-based, Field Induced Quantum Critical Materials
Pulsed Field	Tozer, S.W., NHMFL	Quantum Oscillations in CeIn_3 by Skin Depth Measurements
UF Physics	Ingersent, K., UF, Physics	Converting Spin into Charge in a Dissipative Kondo System

Magnet Technology – 8 Reports

Facility	PI, Affiliation	Report Title
DC Field	Markiewicz, W.D., NHMFL, MS&T	YBCO Coated Conductor Coils at High Stress Levels
DC Field	Sumption, M. The Ohio State U., CSMM, MSE	Variations in B_{c2} and B_{irr} of Ti and Ta Doped Nb_3Sn Strands with Heat Treatments
DC Field	Xu, T., MS&T, NHMFL	Development of the 20 kA Joints for the Series Connected Hybrid
MS & T	Bird, M.D., NHMFL, MS&T	Thermohydraulic Analysis of Helium Flow in the NHMFL SCH Magnet Outsert Coil
MS & T	Bird, M.D., NHMFL, MS&T	Design of the NHMFL Split Resistive User Magnet for Scattering
MS & T	Bird, M.D., NHMFL, MS&T	Qualification Measurements of the Mid-Field and Low-Field CICC for the Series-Connected Hybrid Magnet with Effects of Electromagnetic Load Cycling and Longitudinal Strain
MS & T	Zhai, Y., NHMFL	Iron Magnetic Shielding of the Series-Connected-Hybrid Magnet
NMR	Brey, W., NHMFL	Test of Resistive Shim Insert in the Keck Magnet

Magnetic Resonance Techniques – 16 Reports

Facility	PI, Affiliation	Report Title
AMRIS	Gillies, R, Moffitt Cancer Center, Imaging / Radiology	3-Aminopropylphosphonate: A Relaxation Mechanism Profile
AMRIS	Mareci, T.H., UF, Biochemistry and Molecular Biology	An Automatic Impedance Matching System for Multiple Frequency Coils
AMRIS	Simpson, N.E., UF, Medicine	Advances in Monitoring the Function of an Implantable Pancreatic Construct with NMR

Facility	PI, Affiliation	Report Title
DC Field	Gan, Z., CIMAR, NHMFL	High-field QCPMG NMR of Large Quadrupolar Patterns Using Resistive Magnets
DC Field	Gan, Z., CIMAR, NHMFL	Single-scan Spatial Encoding for the Acquisition of High-resolution NMR Spectra Using a 25 T Resistive Magnet
EMR	Dinse, K.-P., FU Berlin, Physics	Cavity-free 240 GHz Pulsed ENDOR Investigation of 1.44 GeV Xe-irradiated LiF
EMR	Morley, G.W., U. College London, London Centre for Nanotechnology	Electrical Readout of ^{31}P Spin Qubits in Crystalline Silicon at High Magnetic Fields
ICR	Hendrickson, C.L., FSU, NHMFL, Chemistry	SIMION Modeling of Ion Image Charge Detection in Fourier Transform Ion Cyclotron Resonance Mass Spectrometry
NMR	Brey, W.W., NHMFL	Improvements to 900 MHz MAS NMR Probe Cold Gas Delivery System
NMR	Fu, R., NHMFL	Efficient Heteronuclear Dipolar Decoupling in NMR of Aligned Samples at High Fields
NMR	Fu, R., NHMFL	Refining Powder Pattern HETCOR: Correlating ^1H and ^{15}N Chemical Shift Tensors
NMR	Gan, Z. CIMAR, NHMFL	A Two-Dimensional Magic-Angle Turning Phase-Adjusted Spinning Sidebands (MATPASS) Experiment
NMR	Grant, S.C., FSU, CIMAR	Quadrature Surface Coils for in vivo Imaging in 900-MHz Vertical Bore Spectrometer
NMR	Grant, SC, FSU, CIMAR	MR Microimaging with a Cylindrical Ceramic Dielectric Resonator at 21.1 T
NMR	Magin, R.L., U. Illinois, Chicago, Bioengineering	Field & Temperature Dependence of Quantitative Magnetization Transfer Imaging at High Fields
NMR	Quine, J.R., FSU, Mathematics/NHMFL	Analysis of Kinked Helices from PISEMA Data

Magnetism and Magnetic Materials – 56 Reports

Facility	PI, Affiliation	Report Title
AMRIS	Santra, S., UCF, NanoScience Technology Center	Ultra-small Multimodal/Multifunctional (Fluorescent and Paramagnetic) Chitosan Nanoparticles
AMRIS	Walter, G.A., UF, Physiology	Manganese Oxide Doped Silica Nanoparticles
CMT/E	Chiorescu, I., FSU / NHMFL	On-chip SQUID Magnetic Measurements in Record High Magnetic Fields
CMT/E	Hoch, M.J.R, NHMFL	Cobaltite Thin Films: ^{59}Co NMR in Epitaxial $\text{La}_{0.5}\text{Sr}_{0.5}\text{CoO}_3$ (001)
CMT/E	Kismarhardja, A.W., FSU, NHMFL, Physics	Dielectric Measurement on Single Crystal FeV_2O_4 in High Magnetic Field
DC Field	Affronte, M., U. Modena and Reggio Emilia, Italy, Department of Physics	Magnetic Ordering of the RE Lattice in REFeAsO : The Odd Case of Sm. A Specific Heat Investigation in High Magnetic Field
DC Field	Aronson, M.C., Brookhaven National Laboratory, Condensed Matter Physics and Materials Science	Plateaux in the Magnetization of $\text{Yb}_2\text{Pt}_2\text{Pb}$ with the Shastry-Sutherland Lattice
DC Field	Brooks, J.S., FSU, Physics	Mössbauer Spectroscopy Study of the Magnetic Transition in λ - $(\text{BETS})_2\text{FeCl}_4$
DC Field	Dalal, N.S., FSU & NHMFL, Chemistry	NMR Study of the Quantum Phase Transition in the 2D Antiferromagnet $\text{Cr}(\text{dien})(\text{O}_2)_2 \cdot \text{H}_2\text{O}$
DC Field	Hill, S. NHMFL and FSU, Physics	High-Frequency EPR Studies within the Ordered Phase of the Antiferromagnetic Spin Dimer Compound $\text{Ba}_3\text{Cr}_2\text{O}_8$
DC Field	Hoch, M.J.R, NHMFL	Spin Dynamics in the Ferromagnetic Phase of the Colossal Response Bilayered Manganite $\text{La}_{1.2}\text{Sr}_{1.8}\text{Mn}_2\text{O}_7$

Facility	PI, Affiliation	Report Title
DC Field	Hong, T., Oak Ridge National Laboratory	Calorimetric Study of the Spin-Luttinger Liquid in a Spin-ladder Material
DC Field	Khodaparast, G., Virginia Tech, Physics	Time Resolved Spectroscopy of InMnAs III-V Magnetic Semiconductors
DC Field	Kim, K.H., Seoul National U., Department of Physics	Magnetic Field-induced Transition in Magnetoelectric Ba ₂ CoGe ₂ O ₇
DC Field	Koyama, K., Tohoku U., Institute for Materials Research	Decomposition Temperature of MnBi to 45T
DC Field	Landee, C. P., Clark U., Physics	Field-dependence of Néel Temperature of a Quasi-2D Quantum Heisenberg Antiferromagnet, [Cu(pz) ₂](ClO ₄) ₂
DC Field	Luke, G.M., McMaster U., Physics and Astronomy	Heat Capacity and Magnetocaloric Effect of the Spin Dimer System Sr ₃ Cr ₂ O ₈
DC Field	McGill, S.A., NHMFL	Second Harmonic Generation in MnTiO ₃
DC Field	Mitrovic, V., Brown U., Physics	Effects of the Applied Magnetic Field Orientation on the Ground State of Cs ₂ CuBr ₄
DC Field	Musfeldt, J.L., U. Tennessee, Chemistry	Absence of Spin Liquid Behavior: Magneto-optical Study of Nd ₃ Ga ₅ SiO ₁₄
DC Field	Musfeldt, J.L., U. Tennessee, Chemistry	Magnetoelastic Coupling in a Quasi-two-dimensional Quantum Antiferromagnet
DC Field	Seehra, M.S., West Virginia U., Department of Physics	Two Step Metamagnetic Transition in Antiferromagnetic b - Ni(OH) ₂ Nanoplatelets
DC Field	Takano, Y., UF, Physics	Fluctuation-Induced Heat Release from Temperature-Quenched Nuclear Spins near a Quantum Critical Point
DC Field	Tsujii, H., Kanazawa U., Department of Physics, Faculty of Education	Thermodynamic Properties of the Quantum Ferrimagnetic Chain CCPA
DC Field	Zhou, H.D., NHMFL	Metamagnetic Transition in Single Crystal Bi ₄ Cu ₃ V ₂ O ₁₄
EMR	Coronado, E., U. Valencia, Spain, Chemistry	Coherent Manipulation of Mononuclear Lanthanide-Based Single-Molecule Magnets
EMR	Hendrickson, D.N.	High Frequency EPR Study of Photoluminescent Mn ₄ Single-Molecule Magnets
EMR	Meisel, M.W., UF Physics	Magnetic Anisotropy of Prussian Blue Analog Films
EMR	Perales-Perez, O., U. Puerto Rico - Mayaguez, Engineering Science & Materials	Mössbauer Spectroscopy of Cobalt Ferrite Nanocrystals
EMR	Shatruck, M., FSU, Department of Chemistry and Biochemistry	The Study of Lanthanide TTF-Phthalocyanine Sandwich-type Complexes by Electron Paramagnetic Resonance (EPR)
EMR	Wiebe, C., U. Winnipeg, Chemistry	EPR Studies on a Frustrated Kagome-like Lattice: Pr ₃ Ga ₃ SiO ₄
EMR	Zorko, A., Jozef Stefan Institute, Ljubljana, Slovenia	ESR Investigation of Quantum Kagome Lattices
EMR	Zvyagin, S.A., Dresden High Magnetic Field Laboratory / FZD	Electron Spin Resonance in the Weakly-Coupled S = 1/2 Dimer System Ba ₃ Cr ₂ O ₈
High B/T	Meisel, M.W., UF Physics	Magnetic Characterization of New Metal Monophosphonates with a Double-Chain Structure
High B/T	Meisel, M.W., UF, Physics	Magnetism, Disorder, and Non-Fermi Liquid Behavior in Na _{0.78} CoO ₂
High B/T	Meisel, M.W., UF, Physics	Interplay of Frustration and Magnetic Field for the 2D Quantum Antiferromagnetic Cu(tn)Cl ₂
Pulsed Field	Alsmadi, A.M., The Hashemite U., Physics Department	Magnetic Properties of Co-Ti Substituted M-type Barium Ferrite
Pulsed Field	Carpenter, M., U. Cambridge, UK, Dept. of Earth Sciences	Influence of Magnetic Field on Elastic and Anelastic Anomalies Associated with Phase Transitions in Pr _{0.48} Ca _{0.52} MnO ₃

Facility	PI, Affiliation	Report Title
Pulsed Field	Fisher, I.R., Stanford U., Department of Applied Physics	Asymmetric Quintuplet Ordered Phase in the Frustrated S=1 Spin-Dimer Compound $\text{Ba}_3\text{Mn}_2\text{O}_8$
Pulsed Field	Jardim, R.F., Universidade de Sao Paulo, Physics	Magnetic Properties of Sr_2YRuO_6 Compounds
Pulsed Field	Klimczuk, T., LANL	Transport Measurements on Y_3Co_7 in Fields to 40 T
Pulsed Field	Landee, C.P., Clark U., Physics	Determination of Upper Critical Fields in Molecular-based Spin Ladders
Pulsed Field	Luke, G.M., McMaster U., Department of Physics and Astronomy	Magnetocaloric Effect of Spin Dimer Compound $\text{Sr}_3\text{Cr}_2\text{O}_8$ in Pulsed Magnetic Fields
Pulsed Field	Luke, G.M., McMaster U., Physics and Astronomy	Pulsed Field Magnetization and Torque/Force Magnetometry of the Spin Dimer System $\text{Sr}_3\text{Cr}_2\text{O}_8$
Pulsed Field	Manson, J.L., Eastern Washington U., Chemistry and Biochemistry	Magnetism Studies of Polymeric Coordination Compounds
Pulsed Field	Manson, J.L., Eastern Washington U., Chemistry and Biochemistry	Specific Heat Studies of a Novel Polymeric Quantum Magnet
Pulsed Field	Manson, J.L., Eastern Washington U., Chemistry and Biochemistry	Magnetization Studies of Polymeric Quantum Magnets
Pulsed Field	Manson, J.L., Eastern Washington U., Chemistry and Biochemistry	Pulsed-field Magnetization Studies of Quantum Magnets
Pulsed Field	Marcenat, C., CEA-Grenoble, France, Institut Nanosciences et Cryogenie, SPSMS-LATEQS	First AC Heat Capacity Measurement in Capacitor-bank-driven Pulsed Fields
Pulsed Field	Nakotte, H., New Mexico State U., Physics	Electrical Resistivity of $\text{UCu}_{4+x}\text{Al}_{8-x}$ Under High Magnetic Field and Low Temperature
Pulsed Field	Nakotte, H., New Mexico State U., Physics	Heat Capacity and Magnetization of $\text{UNi}_{0.5}\text{Sb}_2$ Under Magnetic Field
Pulsed Field	Paduan-Filho, A., Universidade de Sao Paulo, Sao Paulo, Brazil, Instituto de Fisica	Specific Heat vs. Magnetic Field in $\text{NiCl}_2\cdot 4\text{SC}(\text{NH}_2)_2$
Pulsed Field	Shapiro, A.Ya., Shubnikov Institute for Crystallography, Moscow, Russia	Pulsed Field AC-heat Capacity in 2D-AFM System $\text{RbFe}(\text{MnO}_4)_2$
Pulsed Field	Sharma, A.L., San Jose State U., Physics	Influence of Coating on the Magnetocaloric Properties of Nano- Fe_2O_3
Pulsed Field	Zapf, V.S., NHMFL-PFF	Search for Magneto-electric Effects in Rare-earth Nickelates
Pulsed Field	Zapf, V.S., NHMFL-PFF	Magnetic Field-induced Electric Polarization in a Ni-based Organic Quantum Magnet

Metal-Insulator Transitions – 8 Reports

Facility	PI, Affiliation	Report Title
CMT/E	Dobrosavljevic, V., FSU, Physics, NHMFL	Nearly Frozen Coulomb Liquids
CMT/E	Lattner, S.E., FSU, Chemistry	Metal to Semi-metal Transition in CaMgSi Crystals Grown from Mg-Al Flux
CMT/E	Popovic, D., FSU, Physics and NHMFL	Hysteresis and Memory in the Magnetoresistance of Underdoped $\text{La}_{2-x}\text{Sr}_x\text{CuO}_4$ Thin Films
CMT/E	Terletska, H., FSU, Physics and NHMFL	Fingerprints of Intrinsic Phase Separation in Magnetically-doped 2DEG
DC Field Facility	McGill, S.A., NHMFL	Time-resolved Studies of Coupled Dynamics in CER and CMR Manganites

Facility	PI, Affiliation	Report Title
DC Field Facility	Popovic, D., FSU, Physics and NHMFL	Large Positive Magnetoresistance of the Lightly Doped La_2CuO_4 Mott Insulator
DC Field Facility	Tsui, D.C., Princeton U., Electrical Engineering	In-Plane Magnetoresistivity of High-Mobility Dilute Two-Dimensional Electrons in Undoped Si/SiGe Heterostructures
Pulsed Field	Villafuerte, M.J., Lab. de Fisica del Solido, U.N. de Tucumán and Conicet, Physics	Voltage Induced Metal-insulator Transition in ZnO

Molecular Conductors – 6 Reports

Facility	PI, Affiliation	Report Title
DC Field	Epstein, A.J., The Ohio State U., Physics	High Field Magnetoresistance of Organic Semiconductors
DC Field	Kang, W., Ewha Womans U., Physics	Appearance of Beating in the Shubnikov-de Haas Oscillations of the Organic Conductor $\kappa\text{-(BEDT-TTF)}_2\text{Cu(NCS)}_2$ Under Pressure
DC Field	Murata, K., Osaka City U., Graduate School of Science, Physics	Successive Bi-Stable Quantum Phases in HMTSF-TCNQ Induced by Field-Sweep
DC Field	Park, Y.W., Seoul National U., Physics and Astronomy	The Diminishing Magneto Resistance in High Electric Fields in Polyacetylene Nanofibers
DC Field	Uji, S., National Institute for Materials Science, Nano Materials Laboratory	Quest for FFLO State in 2D Organic Superconductor $\kappa\text{-(BEDT-TTF)}_2\text{Cu(SCN)}_2$
EMR	Oakley, R.T., U. Waterloo, Chemistry	Probing Magnetic Interactions in a Ferromagnetic Heavy Atom Radical via HFEPR

Other Condensed Matter – 17 Reports

Facility	PI, Affiliation	Report Title
CMT/E	Bonesteel, N.E., FSU, Physics	Bond Fluctuations in Random Singlet Phases
CMT/E	Bonesteel, N.E., FSU, Physics	Topological Quantum Computation with Read-Rezayi States
CMT/E	Brooks, J.S., NHMFL, Physics	The Effects of Ethylene in the Dielectric Properties of SWCNT Thermoplastic Composites
CMT/E	Cao, J., FSU/NHMFL, Physics	Temperature Dependence of Electron-phonon Thermalization and Its Correlation to Ultrafast Magnetism
CMT/E	Cao, J., FSU/NHMFL, Physics	Ultrafast Electron Beam Imaging of Femtosecond Laser Induced Plasma Dynamics
CMT/E	Vafeek, O.V., FSU/MagLab	Many-body Instability of Coulomb Interacting Bilayer Graphene
DC Field	Behnia, K., ESPCI, Laboratoire Photons et Matière	An Electronic Instability in Bismuth Far Beyond the Quantum Limit
DC Field	Boebinger, G.S., NHMFL/FSU	Magnetostriction Measurements on Bismuth in the Ultra-quantum Limit
DC Field	Choi, E.S., NHMFL	Field Induced Polarization Flop and Linear Magnetoelectric Effect of Antiferromagnetic MnTiO_3
DC Field	Dalal, N.S., FSU & NHMFL, Chemistry	Glassy Behavior in the Metal Organic Framework $[(\text{CH}_3)_2\text{NH}_2]\text{Zn}(\text{HCOO})_3$
DC Field	Gleeson, J.T., Kent State U., Physics	High Field Magneto-Optical Studies of Liquid Crystals and Complex Fluids
DC Field	Ong, N.P., Princeton U., Physics	High-field Experiments on the Topological Insulator Bi_2Se_3
DC Field	Tozer, S.W., NHMFL	Quantum Oscillations in α -Uranium at Ambient Pressure

Facility	PI, Affiliation	Report Title
Pulsed Field	Bollinger, R.K., Montana State U., Department of Physics	Search for Specific Heat Anomalies in Niobium and Vanadium
Pulsed Field	Huber, T.E., Howard U., Chemistry	Observation of Three-dimensional Behavior in Surface States of Bismuth Nanowires and the Evidence for Bulk Bi Surface-quasiparticles
Pulsed Field	Kono, J., Rice U., Electrical and Computer Engineering	Infrared Absorption of Carbon Nanotubes in Megagauss Fields
Pulsed Field	Tozer, S.W., NHMFL	Magnetization Measurements of α -Uranium Using a Piezoresistive Cantilever in Pulsed Magnetic Fields

Quantum Fluids and Solids – 8 Reports

Facility	PI, Affiliation	Report Title
DC Field	Schmiedeshoff, G.M., Occidental College, Physics	Magnetostriction and Thermal Expansion of a Nearly Saturated ^3He - ^4He Mixture
EMR	Sherwin, M.S., UCSB, Physics and Institute for Terahertz Science and Technology	Spin Decoherence of Fe_8 Single-molecule Magnets
High B/T	Candela, D. U. Massachusetts, Physics	Nuclear Spin Relaxation of ^3He Impurities in Solid ^4He
High B/T	Candela, D., U. Massachusetts, Physics	Nanodroplet Formation in Solid Solutions of Very Dilute ^3He in Solid ^4He
High B/T	Pan, W, Sandia National Laboratory	Crossover from Non-universal Scaling Regime to Universal Scaling Regime in Quantum Hall Plateau Transition
High B/T	Sullivan, N.S., UF, Physics	Magnetic Susceptibility Measurements in High Magnetic Fields and at Ultra-Low Temperatures
Pulsed Field	Prokes, K., Helmholtz-Zentrum Berlin für Materialien und Energie GmbH, Inst. for Complex Magnetic Materials	Magnetic Anisotropy in Natural Malachite and Epidote Single Crystals
UF Physics	Sullivan, N.S., UF, Physics	Nuclear Spin Relaxation Spectroscopy for Determining Molecular Kinetics

Semiconductors – 42 Reports

Facility	PI, Affiliation	Report Title
CMT/E	Kono, J, Rice U., Electrical Engineering	Interference-induced Terahertz Transparency in a Semiconductor Magneto-Plasma
CMT/E	Yang, K., NHMFL	Theoretical Studies of Fractional Quantum Hall Liquid at Landau Level Filling Factor 5/2
CMT/E	Yang, K., NHMFL	Theoretical Studies of Single- and Bi-layer Graphene
DC Field	Ashoori, R.C., Massachusetts Institute of Technology, Physics	Electronic Compressibility and Magnetism at the $\text{LaAlO}_3/\text{SrTiO}_3$ Interface
DC Field	Behnia, K., ESPCI, LPEM	Nernst Effect in Graphite Beyond the Quantum Limit
DC Field	Chen, Y.P., Purdue U., Physics and ECE	Magnetotransport in Graphene
DC Field	de Heer, W.A., Georgia Tech, School of Physics	Half Integer Quantum Hall Effect in High Mobility Single Layer Epitaxial Graphene
DC Field	Drichko, I.L., A.F. Ioffe Physicotechnical Institute	Magnetoresistance in p-Si/SiGe/Si Heterostructures in Tilted Magnetic Fields
DC Field	Du, R.R., Rice U., Physics and Astronomy	Quantum Transport in InAs/GaAs Composite Quantum Wells

Facility	PI, Affiliation	Report Title
DC Field	Engel, L.W., NHMFL	Evidence for Wigner Crystal of $e/3$ Charged Quasiparticles
DC Field	Engel, L.W., NHMFL/FSU	Pinning Mode Resonance of a Skyrme Crystal near Landau Level Filling Factor $\nu=1$
DC Field	Fedorov, G., Russian Research Centre	Tuning the Bandgap of Semiconducting Carbon Nanotube by an Axial Magnetic Field
DC Field	Furis, M., U. Vermont, Physics	Spin- Resolved Photoluminescence of GaN/AlN Quantum Wells and Colloidal CdS Quantum Dots in High Magnetic Fields
DC Field	Gervais, G., McGill U., Physics	Field Induced 2D-3D Transition in a Quantum Well: Colossal Magnetoresistance and Metal-Insulator-metal Transition in a Weakly Interacting Fermi Liquid
DC Field	Hilton, D.J., U. Alabama at Birmingham, Physics	The Complex Terahertz Magnetoconductivity Tensor of a High-Mobility Two-Dimensional Electron Gas
DC Field	Kim, P., Columbia U., Physics	Symmetry Breaking of the Zero Energy Landau Level in Bilayer Graphene
DC Field	Kono, J., Rice U.	Ultrafast Absorption and Emission from 2D High-Density Magneto-Plasma: Absence of Excitonic Mott Transition
DC Field	Lau, C.N., UC Riverside	Quantum Transport in High Quality Graphene pnp Junctions
DC Field	Levy, J., U. Pittsburgh, Physics and Astronomy	Magnetotransport in Nanostructures at the $\text{LaAlO}_3/\text{SrTiO}_3$ Interface
DC Field	Pan, W., Sandia National Labs	Transition from Fractional Quantum Hall Liquid to Pinned Wigner Solid in Two Dimensional Charge Carrier Systems
DC Field	Santos, M.B., U. Oklahoma, Physics & Astronomy	Intersubband Absorption by Electrons in InSb Quantum Wells with an In-Plane Magnetic Field
DC Field	Shayegan, M., Princeton U., Electrical Engineering	Ferromagnetic Fractional Quantum Hall States in a Valley Degenerate Two-Dimensional Electron System
DC Field	Smirnov, D., NHMFL	Magneto-Raman Spectroscopy of Graphite – First Results
DC Field	Smirnov, D., NHMFL	600 GHz Emission from Quantum Cascade Lasers
DC Field	Stormer, H. L., Columbia U., Physics & Applied Physics	Cyclotron Resonance at the Charge Neutral Point of Graphene
DC Field	Suchalkin, S., SUNY at Stony Brook	Cyclotron Resonance in InAs/GaSb Type II Superlattices for Mid-IR Photodetectors
DC Field	Tutuc, E., UT Austin	Quantum Hall Effect in Dual-Gated Graphene Bilayers
DC Field	Valla, T., Brookhaven National Laboratory, Condensed Matter Physics & Materials Science Department	The Magneto Transport of Graphene in Parallel Magnetic Field
DC Field	Wang, Y.-J., NHMFL-FSU	Magneto Optical Study of GaSb-InAs-AlSb Quantum Wells
DC Field	Wang, Y.-J., NHMFL-FSU	Resonant Subband Landau Level Coupling in the Wide Quantum Well
DC Field	Wang, Y.-J., NHMFL-FSU	The Study of Sub-millimeter Wave Induced Zero Resistance Effect at 3He Temperature
DC Field	Wessels, B.W., Northwestern U., Materials Science and Engineering	Magnetotransport Measurements on III-Mn-V Semiconductor Thin Films and Devices
DC Field	Ye, P.D., Purdue U., Department of Electrical and Computer Engineering and Birk Nanotechnology Center	Pronounced Half-Integer Quantum Hall-Effect on Epitaxial Graphene up to 70K
DC Field	Zaliznyak, I. A., Brookhaven National Laboratory, CMPMS	Breakdown of the QHE and Insulating Behavior on the $N=0$ Landau Level in Graphene
EMR	Strouse, G.F., FSU, Chemistry	High Frequency EPR Characterization of Distinct Mn(II) Occupation Sites in Mn:CdSe Quantum Dots

Facility	PI, Affiliation	Report Title
EMR	Zvanut, M.E., U. Alabama at Birmingham, Physics	High Frequency EPR Study of Mg in Thin Film GaN
Pulsed Field	Crooker, S.A., NHMFL-LANL	Spin Noise of Electrons and Holes in Self-Assembled InGaAs Quantum Dots
Pulsed Field	Hayes, S.E., Washington U., St. Louis, Chemistry	Optical Magneto-absorption Measurements of GaAs Semiconductors
Pulsed Field	Klimov, V.I., LANL, C-PCS	Intrinsic Radiative Rates of Infrared-Emitting Germanium Nanocrystals
Pulsed Field	Klimov, V.I., Los Alamos	Polarized Magneto-Photoluminescence from Mn-doped ZnSe/CdSe Core/Shell Nanocrystals
Pulsed Field	Samarth, N., Penn State U, Physics	Magneto-photoluminescence Measurements of Single MBE-grown (Zn,Mn)Se Nanowires
Pulsed Field	Schaller, R., LANL, Chemistry	Probing Dark Exciton States in Lead Salt Nanocrystals

Superconductivity – Applied – 25 Reports

Facility	PI, Affiliation	Report Title
Applied Superconductivity Center (ASC)	Hellstrom, E.E., NHMFL-ASC	Chemical Interaction Between Ag-Sheathed Bi-2212 Round Wire Conductor and Alumino-Silicate Braid
ASC	Hellstrom, E.E., NHMFL-ASC	Growth and BaZrO ₃ Doping of YBCO on RABiTS Substrates Using a Fluorine-free MOD Process
ASC	Larbalestier, D. C., NHMFL-FSU, ASC	Effects of Neutron Irradiation on Properties of Iron Pnictide Superconductors
ASC	Larbalestier, D. C., NHMFL-FSU, ASC	High J _c and Strong c-Axis Vortex Pinning in Co-doped BaFe ₂ As ₂ Single Crystal Thin films Produced by Template Engineering
ASC	Larbalestier, D.C., NHMFL-ASC	In Field Low Temperature Laser Scanning Study of IBAD YBCO Coated Conductor
ASC	Larbalestier, D.C., NHMFL-ASC	Characterization of Bi ₂ Sr ₂ CaCu ₂ O _x /Ag Conductor Extracted from Wind and React Solenoids
ASC	Larbalestier, D.C., NHMFL-ASC	Development of High Critical Current Density in Multifilamentary Round-wire Bi ₂ Sr ₂ CaCu ₂ O _{8+δ} by Strong Overdoping
ASC	Larbalestier, D.C., NHMFL-ASC	In Field Low Temperature Laser Scanning Study of IBAD YBCO Coated Conductor
ASC	Larbalestier, D.C., NHMFL-ASC	Intergrain Current Flow in a Randomly Oriented Polycrystalline SmFeAsO _{0.85} Oxypnictide
ASC	Larbalestier, D.C., NHMFL-FSU, ASC	Current Transport at Grain Boundaries in Superconducting Ba(Fe _{1-x} Co _x) ₂ As ₂ Bicrystals
ASC	Lee, P.J., NHMFL-ASC	Evidence for Suppressed Superconductivity Across Grain Boundaries in SRF Quality Niobium
ASC	Lee, P.J., NHMFL-ASC	Metallographic Examination of Large Scale ITER Toroidal Field CICC after Sultan Testing
ASC	Schwartz, J., NCSU	Dynamic Magneto-Optical Imaging of Transport Current Redistribution and Normal Zone Propagation in YBa ₂ Cu ₃ O _{7-δ} Coated Conductor
ASC	Schwartz, J., NCSU, Materials science and Engineering	Fiber Bragg Optical Sensors for YBCO Applications
ASC	Solovyov, V., Brookhaven National Lab.	Correlation Between YBa ₂ Cu ₃ O ₇ Nuclei Density and the Grain Orientation of the CeO ₂ Buffered Ni-W Template of the Second-generation Superconducting Wire

DC Field	Christen, D.K., ORNL	Angular Dependence of the Irreversibility Field in doped REBCO
DC Field	Jin, R., ORNL	Upper Critical Field in the Different Fe-based Superconductors
DC Field	Larbalestier, D.C., NHMFL-ASC	Study of Grain Connectivity and Flux Pinning Effect in Polycrystalline and Single Crystal Thin Films of $\text{Ba}(\text{Fe}_{1-x}\text{Co}_x)_2\text{As}_2$ Superconductors
DC Field	Larbalestier, D.C., NHMFL, ASC	Angular Dependence of J_c of YBCO Coated Conductors at Low Temperature and Very High Magnetic Fields
DC Field	Lee, P.J., NHMFL-ASC	The Effects of Variable Sn Content on the Properties of A15 Superconducting Nb_3Sn
DC Field	Parrell, J.A., Oxford Superconducting Technology	Characterization of Nb_3Sn Strand Designed for ~1 GHz NMR
Pulsed Field	Batlogg, B., ETH Zurich, Switzerland, Solid State Physics Lab.	Anisotropy of Magneto-transport in FIB-carved $\text{LnFeAs}(\text{O},\text{F})$ (Ln= La, Nd, Pr, Sm) Single Crystal Nanostructures
Pulsed Field	Larbalestier, D.C., FSU-NHMFL, ASC	Transport Characterization of CH_4 HPCVD Carbon-doped MgB_2
Pulsed Field	Maierov, B., LANL, MPA-STC	Angular Dependence of the $\text{YBa}_2\text{Cu}_3\text{O}_{7-x}\text{BaZrO}_3$ Irreversibility Line
Pulsed Field	Miura, M., Superconductivity Research Laboratory-International Superconductivity Technology Center	Vortex Liquid-glass Transition Up to 60 T in Nano-engineered Coated Conductors

Superconductivity – Basic – 45 Reports

Facility	PI, Affiliation	Report Title
Applied Superconductivity Center	Li, Q., Pennsylvania State U., Physics	High Upper Critical field of Carbon-doped MgB_2 Thin Films by HPCVD using TMB
CMT/E	NHMFL and FSU, Physics	Measurement of the Nonlinear Meissner Effect in Superconducting Nb Films Using a Resonant Microwave Cavity: A probe of unconventional pairing symmetries
CMT/E	Gor'kov, L.P., NHMFL	Superconducting and Structural Properties of Iron Pnictides in Frameworks of Two-Band Nesting model
CMT/E	Gor'kov, L.P., NHMFL	Theoretical Investigation of Multiband Superconductors in High Magnetic Fields
CMT/E	Pines, D., ICAM, UC Davis	Two-component Phenomenological Model of Normal Scaling Behavior in Underdoped High-temperature Superconductors
DC Field	Alireza, P.A., U. College London, Physics	Evolution of the Fermi Surface of CaFe_2As_2 with Pressure
DC Field	Balicas, L., NHMFL	Interplay Between Metamagnetism and the Upper-critical Field in $\text{SmFeAsO}_{0.9}\text{F}_{0.1}$
DC Field	Boebinger, G.S., NHMFL/FSU	Quantum Oscillations in the Specific Heat of YBCO 6.55
DC Field	Boebinger, G.S., NHMFL/FSU	High Field Specific Heat of Ultraclean YBCO 6.55
DC Field	Bonn, D.A., U. British Columbia	A Magnetic Field-tuned QCP in the Irreversibility Field of an Underdoped High Temperature Superconductor?
DC Field	Brooks, J.S., FSU / NHMFL, Physics	Investigation of Interplay between Ferromagnetism and Superconductivity in Single Crystal UCoGe
DC Field	Brown, S. E., UCLA, Physics and Astronomy	^{13}C NMR Spectroscopy and Relaxation in κ -(BEDT-TTF) $_2\text{Cu}(\text{NCS})_2$ in Aligned Fields
DC Field	Canfield, P.C., Iowa State U. and Ames Laboratory, Physics and Astronomy	Magneto-resistance in CaFe_2As_2 Under Pressure

Facility	PI, Affiliation	Report Title
DC Field	Carrington, A., U. Bristol, HH Wills Physics Laboratory	de Haas-van Alphen Effect Measurements of Overdoped $Tl_2Ba_2CuO_{6+\delta}$
DC Field	Coldea, A.I., Bristol U., UK, HH Wills Physics Laboratory	Topological Change of the Fermi Surface in Ternary Iron Pnictides with Reduced c/a Ratio: A de Haas-van Alphen Study of $CaFe_2P_2$
DC Field	Dagan, Y., Tel Aviv U., School of Physics and Astronomy	Anomalous Magneto-transport at the Superconducting Interface Between $LaAlO_3$ and $SrTiO_3$
DC Field	Dordevic, S.V., U. Akron, Department of Physics	Magneto-optical Study of Novel Iron-based Superconductors
DC Field	Ferdeghini, C, CNR-INFN-Lamia	Huge Upper Critical Field and Multiband Conduction in the 11 Phase of the Newly Discovered Fe-based Superconductors
DC Field	Ganapathy, S., SUNY Buffalo, Physics	Microwave Conductivity Measurements Near the Superconductor-insulator Quantum Critical Point
DC Field	Goddard, P.A., U. Oxford, Physics	What Can We Learn from the Angle-dependence of Quantum Oscillations in $YB_{a_2}Cu_3O_{6+x}$?
DC Field	Halperin, W.P., Northwestern U., Physics	Spatially Resolved NMR Studies of $Bi_2Sr_2CaCu_2O_{8+\delta}$
DC Field	Halperin, W.P., Northwestern U., Physics	Vortex Dynamics and Gap Nodes in $Ba(Fe_{0.93}Co_{0.07})_2As_2$ from ^{75}As NMR
DC Field	Harrison, N., LANL, MPA-cmms	Investigation of Dirac-nodal Quasiparticles in the Parent Antiferromagnetic Phase of FeAs High Tc Superconductors
DC Field	Karpinski, J., ETH-Zurich	Field-temperature Phase Diagram of the Antiferromagnetic State of Sm Ions in $SmFeAsO$
DC Field	Larbalestier, D.C., ASC-NHMFL	Small Anisotropy, Weak Thermal Fluctuations, and High Field Superconductivity in Co-doped Iron Pnictide $Ba(Fe_{1-x}Co_x)_2As_2$
DC Field	Lonzarich, G.G., U. Cambridge	Landau Level Physics in an Underdoped High Temperature Superconductor $YBa_2Cu_3O_{6.56}$
DC Field	Neumeier, J.J., Montana State U., Physics	Magnetoresistance of Quasi-one-dimensional $Li_{0.9}Mo_6O_{17}$
DC Field	Newman, N., Arizona State U., Materials	Investigation of the Magnetic Properties of Novel MgB2 Thin Films with High H_{c2} Values
DC Field	Opeil, C.P., Boston College, Physics Department	Constructing the Superconducting Phase Diagram of $V_3Si_{0.98}X_{0.02}$ with $X=Mn, Fe, Co, Ni, Cu$
DC Field	Stewart, G.R., UF Physics, Physics	Specific Heat to 0.1 K in High Magnetic Field of Iron Pnictide Superconductors and Restricted Dimension Quantum Critical Systems
DC Field	Tanner, D.B., UF, Physics	Pump-Probe Measurements on the Electron Doped Cuprate PCCO
DC Field	Urbano, R.R., NHMFL	Field Induced Ordered Moment in Under-doped $Ba_{1-x}K_xFe_2As_2$
DC Field	Zheng, G.-Q, Okayama U., Physics	High-field NMR Study on the Pseudogap State in High-Tc Copper-Oxide $Bi_2Sr_{2-x}La_xCuO_{6+\delta}$
Pulsed Field	Analytis, J.G., Stanford U., Applied Physics	Elastic Properties of the Pnictide $Ba(Fe_{1-x}Co_x)Fe_2As_2$
Pulsed Field	Bauer, E., LANL	Investigation of Uranium Compounds in Ultrastrong Magnetic Fields
Pulsed Field	Boebinger, G.S., NHMFL/FSU	Transport Measurements of Ultraclean Thin Film of Optimally Doped LSCO

Facility	PI, Affiliation	Report Title
Pulsed Field	Fanelli, V.R., NHMFL MPA-cmms, LANL	Resonant Ultrasound on LSCO samples from 300 K to 4 K
Pulsed Field	Hosono, H., Tokyo Institute of Technology, Tokyo, Japan	Magneto Resistance in a SrFe ₂ As ₂ Epitaxial Film
Pulsed Field	Kim, K.H., Seoul National U., Physics	Upper Critical Field Measurement on SrFe _{1.85} Co _{0.15} As ₂ Single Crystal
Pulsed Field	Matutes Aquino, J.A., CIMAV, Chihuahua, Mexico	Magnetism, and Magneto-Transport in Ferromagnetic Superconducting Rutheno-Cuprates Ru _{1-x} Nb _x) Sr ₂ (Eu _{1.5} Ce _{0.5})Cu ₂ O ₁₀
Pulsed Field	Sebastian, S.E., Cambridge	Metal-insulator Quantum Critical Point Revealed Beneath the High Tc Superconducting Dome
Pulsed Field	Sebastian, S.E., Cambridge, UK, Physics	Fermi Liquid Behavior in Underdoped High Tc Superconductors
Pulsed Field	Yaun, H.Q., Zhejiang U., China	Weak Anisotropy of the Superconducting Upper Critical Field in Fe _{1.11} Te _{0.6} Se _{0.4} Single Crystals
UF Physics	Hirschfeld, P.J., UF Physics, Physics	Disorder- and Magnetic Field Induced Magnetic States of Cuprate Superconductors
UF Physics	Hirschfeld, P.J., UF Physics, Physics	Effect of Disorder on Iron Pnictide Superconductors

Appendix C: Publications & Activities Index

A

Abernathy, C., 153, 158
 Abou Hamad, I., 152
 Abouchami, W., 130
 Abrahams, E., 125
 Abraimov, D., 131-132, 146, 152
 Acharya, S., 126
 Acker, J., 128
 Aczel, A.A., 32, 125, 139
 Adak, S., 125
 Adams, E.D., 137
 Adams-Hughes, M., 153
 Affronte, M., 135
 Afzal, A., 132
 Agosta, C.C., 127, 154
 Aguiar, M.C., 125
 Aharen, T., 125
 Ahif, D.R., 132
 Ahlf, D., 144-145, 150
 Ajredini, R., 131, 141
 Al-Hassanieh, K.A., 134-135
 Alamo, R.G., 130
 Alborn, H.T., 131, 141
 AlDamen, M.A., 79
 Allard, L.F., 138
 Allenson, S., 152
 Alloul, H., 125
 Almeida, M., 129
 Alsmadi, A.M., 125
 Altarawneh, M., 17, 125, 135
 Althaus, E., 139
 Alver, U., 129
 Alves, T.E.P., 131
 Alyones, S., 125
 Amoureux, J.P., 130
 Analytis, J. G., 21, 125, 127
 Andersen, B.M., 125, 127
 Ando, Y., 126
 Andrade, E.C., 125, 139
 Andraka, B., 125
 Andrew, C. M., 127
 Angerhofer, A., 133, 158
 Angst, M., 152

Antharam, V.C., 125, 132
 Arenas, D.J., 139, 149
 Armentano, D., 133
 Armentrout, P.B., 135, 141
 Armstrong, G.S., 135
 Armstrong, S.A., 130, 143
 Arthur, K.E., 136
 Artz, R., 142
 Asomaning, S., 133, 147
 Astarly, G.W., 131-132
 Atake, T., 131
 Atkins, B.M., 131
 Avci, S., 134
 Avouris, P.H., 136
 Ayala-Valenzuela, O.E., 125-126

B

Badri, D.V., 131
 Baek, S. H., 126, 132
 Bai, H., 126, 139, 142
 Baily, S.A., 36, 126, 131-133, 138-140, 146-147, 152
 Balakirev, F. F., 126, 131, 135, 138-139, 144, 146, 149
 Baldock, J.A., 130
 Balicas, L., 125-131, 134-135, 138-140, 142, 144-145, 148-149, 151
 Bangura, A. F., 125, 127
 Baraban, M., 126
 Bark, C. W., 132
 Barlas, Y., 126
 Barrios, M.N., 139
 Barzi, E., 135, 148
 Barzykin, V., 126
 Bassil, B.S., 133
 Batista, C.D., 135, 149
 Bauer, E.D., 126, 130, 142, 146, 153
 Baxter, M., 140
 Beattie, S.G., 126
 Beck, B., 142
 Bedell, K.S., 135
 Bedorf, D., 131
 Beedle, C.C., 132, 137, 139-140, 146
 Behnia, K., 128, 139
 Belman, N., 126
 Belyanin, A.A., 145
 Ben Shalom, M., 135
 Bengtsson, N.E., 76
 Benmelouka, M., 126
 Benninger, R.K., 135
 Berger, C., 15
 Bert, F., 138
 Bertaina, S., 126, 129
 Besara, T., 139, 146
 Betancourt, S.S., 136
 Betts, J.B., 126, 134, 136, 150
 Betts, J.J., 139
 Beu, S.C., 130, 139, 143, 151-152
 Bhupathi, H.J., 126, 153
 Biasatti, D., 138, 153
 Biboum, R.N., 133
 Biner, D., 137
 Bird, M.D., 126, 128, 134, 138-139, 142, 152, 155
 Bischoff, A., 144
 Bishop, N.C., 153
 Biswas, A., 136, 158
 Biswas, S., 136
 Bizimis, M., 136, 149-150
 Blackband, S.J., 76, 127-128, 136, 158
 Blackburn, M.E., 126, 129, 131
 Blackledge, M., 133, 135
 Blakney, G.T., 130-131, 139, 141, 143-144, 146-148, 150-152
 Blanchard, J.S., 129, 142, 152
 Blichert-Toft, J., 130
 Blunk, D., 135, 141
 Bobroff, J., 125
 Boebinger, G.S., 8, 126, 130, 135, 144, 149, 155
 Boehme, C., 133, 137, 147
 Boldin, I., 148
 Bole, S.T., 126, 139
 Bolen, M.L., 136
 Bolin, E., 128, 132, 146
 Bollinger, K., 139
 Bonesteel, N.E., 28, 126, 130, 138-139, 150, 154, 159
 Bonito-Oliva, A., 128
 Bonn, D. A., 135

Bonora, M., 129
 Bontchev, R.P., 134
 Booker, C.F., 128, 136
 Borel, A., 126
 Bortoluzzi, A.J., 137
 Bosque, E., 130, 139, 143
 Botello-Zubiate, M.D., 126
 Botello-Zubiate, M.E., 126
 Botez, C.E., 126
 Bou-Assaf, G.M., 138, 140, 153
 Bouillot, P., 137
 Boukhehdaden, K., 133
 Bourg, J., 129, 135
 Bouvignies, G., 133, 135
 Bowers, C.R., 154
 Boyd, G.R., 126, 133
 Bozovic, I., 128, 149
 Brechin, E.K., 128, 130
 Brenig, W., 131
 Brennecke, J.F., 133
 Brey, W.W., 129-130, 133, 135, 140, 142, 149
 Brinzari, T. V., 134, 137, 152
 Britt, R. D., 136
 Brodbelt, J.S., 126
 Broholm, C.L., 135
 Brooks, J.S., 125, 127, 129, 134, 138-139, 146, 148-149, 155
 Brown, C.M., 135
 Brown, G., 76, 137
 Brown, S. E., 149
 Brunel, L.C., 126, 137-138, 147
 Bruschiweiler, R. A., 8, 131-133, 135-136, 138, 141, 152-153
 Bruschiweiler, Rafael P., 155
 Bruschiweiler-Li, L., 138, 152
 Bruzzzone, P., 128
 Brynda, M., 126, 136
 Brzostek, A., 148
 Bud'ko, S.L., 134, 137
 Buendia, G.M., 126
 Bui, J.D., 76, 128
 Bukowski, Z., 130
 Bukrinsky, M., 135
 Burnett, D.S., 151
 Burrell, A.K., 146
 Busath, D.D., 149
 Bussian, D.A., 126

Bustamante, D., 136
 Buvaylo, E.A., 126
 Buyers, W.J.L., 130

C

Caballero, S., 132
 Cadars, S., 126
 Cadden-Zimansky, P., 126, 143
 Cadotte, A.J., 126
 Cai, S.H., 134, 138
 Camacho, J., 138
 Campbell, A.J., 135
 Campbell, R.E., 128-129
 Campbell-Thompson, M., 126
 Candela, D., 130
 Canepa, F., 127
 Canfield, P.C., 129, 134, 137
 Cantrel, K.R., 126
 Cantrell, K.R., 128, 139
 Canzar, S., 139
 Cao, C., 131, 139, 149
 Cao, H., 138
 Cao, J., 132, 134, 137, 155
 Capan, C., 126, 134, 142
 Capano, M.A., 136
 Cappendijk, S.L.T., 142, 153
 Carney, P.R., 126
 Carpenter, C., 140
 Carrington, A., 127
 Carson, C.G., 126
 Carter, J.D., 133, 137, 150
 Casellato, A., 137
 Cason, A.M., 127
 Castro-Gamboa, 77
 Catherman, A.D., 132, 150
 Cava, R.J., 127, 137
 Caywood, W., 149
 Chakov, N.E., 135
 Chamoun, J.E., 140
 Chan, H.B., 125, 139, 148
 Chan, W.K., 127
 Chandra, S.B., 132
 Chandrasekhar, V., 126
 Chang, K.-H., 132
 Chang, K.C., 128

Chang, S., 125
 Chantis, A.N., 127
 Chanton, J., 137, 155
 Chapin III, F.S., 137
 Chapman, 73
 Checkelsky, J.G., 127
 Cheesman, A.W., 140
 Cheetham, A.K., 130, 139
 Chekmenev, E.Y., 127
 Chen, G.F., 138, 152
 Chen, H. M., 127-128, 130, 135, 144, 149
 Chen, J., 126
 Chen, K.-Y., 137, 140, 144
 Chen, L., 126-127
 Chen, R., 132
 Chen, W., 127
 Chen, X.H., 130, 135, 144, 149
 Chen, X.M., 131
 Chen, Y.M., 127, 133, 138, 146, 152
 Chen, Y.P., 138
 Chen, Z.J., 127, 134, 138
 Cheng, H.-P., 131, 139
 Cheng, L., 127
 Cheng, M., 127, 140
 Cheng, P., 144
 Cheong, S.-W., 130-131, 137, 145
 Chepurnykh, T.V., 136
 Cherian, J., 142, 147, 150
 Chiatti, O., 127, 138
 Chichester, J. W. 129
 Chiorescu, I., 126-127, 129
 Chiu, Y.T., 136
 Chmelka, B.F., 126
 Cho, K., 127, 154
 Cho, S., 138
 Choi, E.S., 129-130, 138, 144
 Choi, K.-Y., 126, 139, 146
 Choi, Y.J., 130, 145
 Christen, D.K., 129, 138, 147, 152
 Christensen, B.N., 137
 Christensen, J., 129
 Christianson, A., 152-153
 Christianson, A.D., 153
 Christianson, E.D., 142
 Christou, G., 130, 132, 135, 143, 148
 Chu, J.-H., 125, 127
 Chu, Y.H., 137

- Chudakov, D.M., 136
 Chumillas, M.V., 154
 Chun, S.H., 145
 Chung, O.H., 131
 Chung, P.H., 128
 Cimberle, M.R., 127
 Citro, R., 137
 Civale, L., 131-133, 136, 138, 140, 146-147
 Čižmár, E., 22, 70, 134
 Clague, D.A., 130
 Clark, D., 142
 Clark, R.J., 130
 Clark, T.E., 127
 Clark, W.G., 149
 Clarkson, M., 129
 Clemente-Juan, J., 133
 Clinite, R., 132, 134, 137
 Clouser, B.W., 138
 Coates, N.E., 138
 Cohen, M., 142
 Coldea, A.I., 21, 127
 Coleman, P., 131
 Collar, K.N., 129, 153
 Collins, A., 130
 Collision, D., 127
 Colman, H., 141, 143, 148, 153
 Coniglio, W.A., 127
 Conlon, T., 126
 Conrad, C.A., 141, 143, 146, 148, 150, 153
 Constantinidis, I., 127
 Constantino, M.H., 138
 Cooke, A., 134, 148
 Cooley, B.J., 127
 Cooley, J., 129, 135, 142
 Cooley, J.C., 129
 Cooper, H.J., 144
 Cooper III, W.T., 155
 Coor, J.L., 140-141
 Copley, J.R.D., 130, 138, 151
 Copping, R., 127
 Cornell, H., 154
 Cotten, M., 127, 129, 140, 142-143, 145
 Cotton, F. A., 50
 Coulter, J.Y., 137
 Cousens, B. L., 130
 Cox, S., 136
 Craig, N.C., 138, 144
 Cranswick, L.M.D., 125
 Creek, J., 152
 Crooker, S.A., 126-127, 130, 134, 136, 140, 143
 Cross, T.A., 127, 129-130, 134-135, 138, 140-141, 147-150, 152, 155
 Crosswhite, M.R., 140, 154
 Crowell, P.A., 127
 Csányi, G., 134, 142
 Cuccoli, A., 23
 Cui, H.B., 127
 Cui, Y., 130
 Cummer, S.A., 138
 Curro, N.J., 126
 Cynn, H., 134
 Cyr-Choinière, O., 127, 140
- D**
- D'Albany, D., 140
 Dabkowska, H.A., 125, 139
 Daemen, L.L., 134
 Dagan, Y., 135
 Dai, Yanhua, 127
 Dalal, N.S., 126, 129-131, 133-134, 138-139, 144, 146
 Dalisay, D.S., 76, 127
 Daly, J.W., 131
 Danielson, L.R., 127, 135
 Daou, R., 127, 140
 Das, O., 140-141
 Das, R., 127, 136, 141
 Das Sarma, S., 127-128
 Datta, S., 79, 128, 130, 132, 135, 139-140, 146, 148, 154
 Davidson, M.W., 128-129, 131, 133, 135-136, 138, 149, 152, 156
 Davis, F.A., 141
 Day, R.N., 128, 136
 Daza, E.L., 140, 142
 De Jongh, L. Jos, 154
 De Munno, G., 133
 Debord, J. D., 133, 147
 DeGregori, J., 135
 Del Barco, E., 128, 130, 143, 145
 DeMarse, T.B., 126
 Demetri, G., 129
 Deng, T., 138
 DeRosa, R., 150
 Deshmukh, G. D., 129
 Devakkumar, A., 148
 Devereaux, T.P., 126
 Dhakal, T., 136
 Dias, J.C., 129
 Dias da Silva, L.G.G.V., 128, 149
 Dickey, E.C., 127
 Diehl, W., 129
 Dillon, R., 148
 Ding, F., 129
 Ding, W., 128
 DiNitto, J. P., 129
 Dinse, K.-P., 137
 Ditto, J.J., 140, 142
 Ditto, W.L., 126
 DiTusa, J.F., 126
 Divan, R., 134
 Dixon, D.A. Jr., 144
 Dixon, I.R., 126, 128, 132-133, 134, 138-139, 142
 Dixon, P.J., 105, 129, 140
 Dixon, Patricia J., 156
 Dobrosavljevic, V., 125, 138-139, 141, 148, 150, 153-154
 Doiron-Leyraud, N., 140
 Doluweera, G.S.P., 131
 Dong, G.C., 128
 Dong, X.L., 131
 Donoghue, J.F., 140-141
 Dordevic, S.V., 128
 Dorsey, A., 154
 Dos Santos, C.A.M., 139
 Dossey, A.T., 128, 131, 137, 141
 Dowden, P.C., 133, 138, 140, 146
 Downes, H., 144
 Downey, S.T., 129, 146
 Dragana Popović, 116
 Drahus, M., 128
 Drake, M.J., 135, 141
 Drayss, M.K., 135, 141
 Dreiocker, F., 141
 Drichko, I.L., 128, 141, 153
 Driscoll, J., 154
 Du, R.-R., 127, 137-138, 141, 154

Du, X., 141
 Dubost, F.X., 136
 Duc, F., 138
 Duc Nguyen, T., 135
 Dufty, J.W., 153
 Dunk, P.W., 147
 Dunn, B.M., 131
 Durbin, K. R., 132
 Durrell, J.H., 146
 Duval, J.M., 129
 Dyakonov, A.M., 128
 Dziadek, J., 148
 Dziedzic, R., 148

E

Ebihara, T., 135
 Edison, A.S., 76, 127-128, 131, 137,
 141, 154, 158
 Efros, A.L., 126
 Efros, Al.L., 130
 Ehmler, H., 126, 134
 Ehrler, C., 139
 Eic, M., 147
 Eichel, R.-A., 128
 Eichfeld, C.M., 127
 Eisenmesser, E.Z., 129, 135
 Eisterer, M., 128
 Eksioğlu, E.A., 131
 Elizalde Galindo, J.T., 126
 Elliott, D.W., 125
 Ellis, P.D., 130
 Elsenmesser, E.Z., 135
 Elsner, J., 140-141
 Elsner, J.B., 140-141
 Emmett, M. R., 53, 57, 129, 133,
 137-143, 146-148, 150-153
 Engel, L.W., 136, 138, 156
 Englad, J., 145
 English, D., 132
 English, J. M., 129
 Eom, C. B., 132
 Epping, J.D., 126
 Eremenko, I.L., 126
 Ermakova, G.V., 136
 Erunal, E., 128
 Eyler, J.R., 158

F

Fagan, J.A., 136
 Fajer, P.G., 140, 156
 Fanelli, V.R., 135, 142, 153
 Fang, L., 144
 Fanucci, G.E., 126, 129, 131, 133,
 137, 150, 158
 Farrell, E.O., 142
 Farver, R.S., 125, 132
 Fauqué, B., 128
 Faus, J., 133
 Favreau, P., 129
 Fedorov, G., 137
 Feher, A., 134
 Feiguin, A.E., 128
 Feldmann, D.M., 140
 Feng, P. L., 128, 130, 143, 145
 Feng, Q.R., 138, 144
 Ferdeghini, C., 127
 Fernandez, J.A., 133
 Ferrera, A., 132
 Ferretti, M., 127
 Fetter, R.D., 136
 Fey, M., 76, 128
 Figueiroa, S.M., 142, 149, 151
 Fish, K.N., 152
 Fisher, A.J., 136
 Fisher, I. R., 125, 127, 135, 145, 149
 Fisk, Z., 126, 129, 134, 142
 Flatow, I., 119
 Flint, J.J., 76, 128
 Flotte, TR, 126
 Fobes, D., 138
 Folkman, C. M., 132
 Foltyn, S.R., 133, 138, 140, 146
 Forder, J.R., 132, 158-159
 Foroutan, P., 142
 Fortune, N.A., 128, 142
 Foyevtsova, K., 129
 Francoual, S., 137
 Frank, M.P., 129
 Franssila, S., 129
 Frantom, P.A., 129, 142, 152
 Frey, F. A., 130
 Frieber, F., 136
 Fritzsche, S., 134

Froelich, P. N., 133, 142, 147,
 150, 154
 Frommer, W.B., 129
 Fu, R., 129, 134-135, 138, 140,
 142, 150
 Fulzele, S., 131
 Furis, M., 130
 Fuzier, S., 130, 143

G

Gabay, M., 125
 Gaboardi, M., 129, 154
 Gaffney, B.J., 152, 156
 Gagnon, K.J., 137
 Gahan, L.R., 137
 Gajiwala, K. S., 58, 129
 Galbraith, C.G., 136
 Galbraith, J.A., 136
 Galiano, L., 129
 Galperin, Y.M., 128
 Gan, Z. H., 129-130, 135, 138,
 142, 144
 Gan, Z.Z., 138, 144
 Ganesh, O.K., 132
 Gao, F.P., 130
 Gapud, A.A., 129, 147
 Garcia-Rubio, I., 133
 Gardino, A.K., 129
 Gardner, J. E., 134, 138, 151
 Gardner, J.S., 138
 Garlid, E.S., 127
 Garlington, W., 132
 Garmestani, H., 132
 Garraffo, H.M., 131
 Garrett, J.D., 130
 Gaunt, A.J., 127
 Gavrilin, A.V., 126, 128, 139, 142
 Ge, Y., 132
 Gebre, T., 142, 147, 150
 Gerber, A., 135
 Geremychkin, E.A., 142
 Gerhard, R.A., 126
 Germain, S., 126, 131
 Ghosh, S., 150
 Giamarchi, T., 137
 Giannakopoulos, E., 48

Gillette, J.M., 136
 Glazkov, V.N., 138
 Glossop, M.T., 127
 Goddard, R. E., 132, 146
 Goetzman, E., 126
 Gokmen, T., 129, 134, 136, 142, 148-149
 Golan, Y., 126
 Gonzalez, M., 134
 Goodall, D.P., 133
 Goodenough, J. B., 127, 140
 Goodrich, R.G., 126, 129
 Gopalan, V., 137
 Gor'kov, P.L., 8, 46, 58, 73, 126, 129, 133, 135, 142, 148-149, 156
 Gordon, E.D., 129, 140, 142
 Goremychkin, E.A., 153
 Goto, T., 137
 Gottardo, M., 128
 Goy, P., 132
 Gozar, A., 128
 Graf, D., 24, 127, 129, 131, 135, 142
 Graf, M.J., 130
 Granroth, G.E., 135
 Grant, M.B., 132
 Grant, S. C., 127, 142, 148
 Graser, S., 129, 132-133
 Greedan, J.E., 125
 Greig, M.J., 129, 152-153
 Grenier, B., 137
 Grey, C.P., 129, 142
 Griesinger, C., 135
 Griffin, V.S., 144
 Grodzicki, A., 50
 Groll, N., 126, 129
 Grossjohann, S., 131
 Grove, C.M., 105, 129
 Groves, M., 141
 Gu, J.J., 136
 Gu, L., 136
 Guibard, I., 147
 Gunasekera, S.P., 136
 Gunn, A., 136
 Gurevich, A., 6, 127, 130-132, 134-135, 138, 142-144, 152-153, 156
 Guzek, M., 148

H

Haam, S.Y., 131
 Haapala, M., 129
 Haase, W., 137
 Haines, K., 45
 Hall, D., 126, 129
 Haller, R., 131
 Halperin, B.I., 138
 Halperin, W.P., 134
 Hamida, J.A., 135
 Hamidane, H.B., 129
 Han, J.H., 131
 Han, K., 129, 132, 146, 150
 Han, R., 149
 Han, X., 130, 143
 Hanko, J., 134
 Hannahs, S.T., 128, 135, 137-138, 142-143, 153
 Hannon, M.J., 144
 Hansel, S., 136
 Hansen, B., 76, 128
 Hao, E., 138
 Hardcastle, K., 126
 Hardy, W. N., 135
 Harima, H., 135
 Harrington, S., 154
 Harrison, N., 17, 131, 133-135, 142, 145
 Hatcher, P.G., 130, 144
 Hauge, R.H., 136
 Hawley, M.E., 146
 Hayes, S.E., 134, 143, 153
 Hazelton, D.W., 129, 147
 Hazelwood, K.L., 131, 133, 136, 138
 He, G., 133
 He, H., 129, 132, 141, 143, 146, 148, 150, 152-154
 He, Y.-A., 129
 He, Z., 150
 Headley, J.V., 130, 143
 Hebard, A.F., 133, 136, 154, 159
 Heddo, M., 131
 Heeger, A.J., 138
 Heinrich, J., 134
 Helliwell, M., 127

Hellstrom, E. E., 34, 37, 128, 131-132, 135-136, 138, 143-144, 146, 149-150, 152
 Helm, L., 126
 Hemmati, A.M., 130, 143, 154
 Hemmetti, A.M., 139
 Henderson, C., 129
 Henderson, J.J., 128, 130, 145
 Henderson, M., 143
 Hendrickson, C. L., 53, 129-131, 135, 139, 141, 143-144, 147-148, 150-152
 Hendrickson, D. N., 128, 130, 132, 137, 139-140, 143, 145-146
 Henriksen, E. A., 16, 143
 Henriques, R.T., 129
 Hermann, R., 152
 Hernandez, J.M., 132
 Hernandez-Maldonado, A.J., 143
 Herren, R., 148
 Hershfield, S.P., 159
 Hess, H.F., 136
 Hibbard, D.J., 129, 140, 142-143
 Hill, D.H., 135
 Hill, S., 8, 128, 130, 132, 135, 139, 141, 143, 145-146, 148-149, 154, 156
 Hiramatsu, H., 126, 132, 139, 146
 Hirano, M., 126, 131-132, 139, 146
 Hirschfeld, P.J., 125-127, 129-133
 Hirschmann, M.M., 141
 Hiscott, P.S., 132
 Hoatson, G.L., 130
 Hobayashi, H., 127
 Hobbie, E.K., 136
 Hoch, M.J.R., 130, 143-144, 146
 Hockaday, W.C., 130, 144
 Hodges, R., 135
 Hoffman, N.W., 144
 Hoffmann, C., 126
 Hoffmann, M.J., 128, 137
 Holesinger, T.G., 133, 136, 138, 140, 146
 Holesinger, T.H., 146
 Holtz, R.L., 129
 Hor, Y.S., 127
 Hormozi, L., 28, 130, 138
 Hosokoshi, Y., 144
 Hosono, H., 126, 131-132, 139, 146

Hotze, A.C.G., 144
 Houpt, T.A., 127, 152, 156
 Hoyos, J.A., 138
 Hsu, H.-F., 137
 Htoon, H., 130, 136
 Hu, J., 130, 140
 Hu, Q.O., 127, 137
 Hu, R., 135
 Hu, X., 140-141
 Hu, Z.-X., 127, 130
 Hua, J., 134
 Huan, C., 130
 Huan, H., 148
 Huang, Q., 147
 Huang, S., 130, 144
 Hubbard, P.L., 62
 Huber, T.E., 130
 Huey, G., 142
 Hughey, C., 153
 Humayun, M., 127, 129-130, 135,
 140-141, 144, 149, 151, 154
 Humayun, Munir, 156
 Hundley, M.F., 126
 Hung, C.-M., 149
 Hung, I., 130
 Hunte, F., 138, 144, 152
 Huzarska, M., 152
 Hwang, D.U., 126
 Hwang, P.I., 128
 Hynes, A., 142



Ibrahim, M., 133
 Ihas, G.G., 137
 Imai, T., 125
 Imazawa, T., 144
 Ingersent, J. K., 127-128, 131, 140,
 144, 149, 153, 159
 Inglett, P.W., 140
 Inglis, R., 130
 Inoue, K., 144
 Irving, A.J., 149
 Isern, N.G., 135
 Islam, Z., 152
 Issi, J-P, 128
 Ivana Raičević, 118
 Izumi, T., 147
 Izumisawa, S., 131



J. O'Reilly, 41
 Jacobsen, S.B., 144
 Jacques, S. L., 129
 Jaime, M., 125-127, 131, 134-139,
 144, 146
 Jain, P., 130, 139
 James-Smith, M.A., 133
 Jan, P.S., 128
 Jang, H. W., 132
 Janik, J.A., 130, 151
 Jaroszynski, J. J., 130, 135, 138,
 144-145, 147, 149-152
 Jarrell, M., 131
 Jaszewski, A. R., 137
 Jaworski, L., 126
 Jeon, G.-S., 131
 Jeona, K., 130
 Jeong, S., 130
 Jerzykiewicz, M., 48, 137
 Jewell, M.C., 135, 153
 Jezierska, J., 126, 134, 137
 Jho, Y.D., 145
 Ji, Y., 141, 153
 Jia, Q. X., 138, 140, 146
 Jia, Y., 144
 Jiame, M., 135
 Jiang, J. Y., 34, 128, 131-132,
 135-136, 138, 143-144, 146,
 149-150, 152
 Jiang, Z., 143
 Jin, R., 138, 152
 Jin, Z., 130
 Jo, Y.-J., 127, 130-131, 138, 140,
 144-145, 149, 151
 Johannes, M., 125
 Jones, J.C., 127
 Jones, L.F., 130
 Ju, J., 131
 Julve, M., 133
 Junior, A.F., 131
 Juyal, P., 144, 149, 152



Kaczorowska, M.A., 144
 Kaiser, N.K., 143-144, 147, 150
 Kajňaková, M., 22, 70, 134
 Kaliaguine, S., 147
 Kalu, P.N., 129, 146, 153
 Kametani, F., 127, 131-132, 138,
 144, 152
 Kamihara, Y., 131
 Kamizawa, T., 144
 Kanada, K., 137
 Kanchanawong, P., 136
 Kandimalla, K.K., 131
 Kang, J., 134
 Kang, W., 131, 144
 Kano, M., 129, 131, 135, 142
 Kaplan, F., 131, 141
 Karpinski, J., 130
 Karrenbauer, A., 139
 Katrych, S., 130
 Kaur, N., 131, 144
 Kawaji, H., 131
 Kazazic, S., 153
 Kear, J.L., 131
 Keil, F.J., 134
 Keil, K., 144, 151
 Kelleher, N. L., 132, 144-145, 150
 Kellie, 52, 126, 130-133, 140-141,
 143-145, 150
 Kellie, J. F., 132, 144-145, 150
 Kelta, B., 133
 Kem, W.R., 131
 Kemper, A., 131
 Kemper, J.B., 135, 149
 Kenisson, J.A., 146
 Kennison, J.A., 133, 138, 146
 Kent, D.L., 132
 Kenzelmann, M., 134, 152
 Kern, D., 129, 154
 Keshav, S., 150
 Khadka, R.P., 129, 147
 Kharzeev, D.E., 138
 Khodas, M., 138
 Kiefer, K., 137
 Kikugawa, N., 131

- Kilgore, B., 150
 Kim, E.G., 29, 131
 Kim, J.-S., 131
 Kim, J.-W., 131, 145, 152
 Kim, K.H., 131, 145
 Kim, P., 143
 Kim, S. S., 29, 130-131, 145
 Kim, S.H., 145
 Kim, Y.H., 131, 137, 144, 150
 Kimata, M., 129
 Kindo, K., 134
 King, M.A., 76, 128
 Kinvenson, A., 129
 Kiran, M., 148
 Kirchner, S., 131
 Kiryukhin, V., 130
 Kish, S.A., 140-141
 Kismarahardja, A. W., 134, 148
 Klauss, H.-H., 131
 Klimov, V.I., 126, 130, 136
 Klose, U., 60
 Knoll, D.C., 134
 Knowles, E.S., 145
 Kobayashi, A., 127
 Kobayashi, H., 127
 Kogan, V.G., 129
 Kohama, Y., 32, 125-126, 131-132, 135, 139, 146
 Kohler, A.C., 136
 Kohlman, L.W., 128
 Kokozay, V. N., 126
 Kolezhuk, A.K., 138
 Kollath, C., 137
 Komatsu, K., 131
 Kondo, T., 127
 Konishi, Y., 133
 Kono, J., 136, 145
 Kono, J., 136, 145
 Koo, C., 128, 130, 135, 143, 145, 148
 Korenblit, I.Ya., 135
 Kortz, U., 133
 Koshkouei, A.J., 133
 Kostianen, R., 129
 Kothapalli, K., 125
 Kotiaho, T., 129
 Kotliar, G., 125
 Koukis, D., 139
 Kowalczyk, A., 150, 154
 Kozlova, A.S., 140, 142, 145
 Kramerova, I., 131
 Kremers, G.J., 131, 135
 Kroeker, S., 125
 Kroes, R.A., 141, 143, 148, 153
 Kroto, H.W., 130, 139, 147
 Krzystek, J., 133-134, 137, 145
 Krämer, W.K., 137
 Kuang, G.C., 138
 Kucharczyk, C., 125
 Kudryashova, E., 131
 Kuga, K., 134, 142
 Kuhnle, A.D., 137
 Kuhns, P.L., 126, 130-131, 134, 138-139, 143-144, 146, 149
 Kumar, A., 137, 144
 Kumar, S., 137
 Kumari, S., 128, 136
 Kumashiro, R., 131
 Kungl, H., 128, 137
 Kwan, J. C., 56, 131-132
 Kwan, M.L., 144
 Kwok, W.K., 134
 Kwon, B., 127
 Kühne, H., 131
- L**
- Labbe, G., 137
 Labeikovskiy, W., 129, 135
 Lacerda, A.H., 125, 134, 137
 Lagarias, J.C., 136
 Lakomek, N., 135
 Laliberte, F., 140
 Lampropoulos, C., 132, 135, 148
 Landee, C. P., 131
 Landee, C.P., 131
 Landing, W., 142, 156
 Lang, F.F., 141, 153
 Larbalestier, D. C., 36, 127-132, 134-136, 138, 144-152, 156
 Larson, C., 149
 Lashley, J.C., 129, 142
 Lawrence, J.M., 132, 140, 142, 146, 153
 Leadley, D.R., 128, 141, 153
 LeBoeuf, D., 127, 140
 Ledbetter, H., 134
 Lee, 34-35, 52-53, 76, 93, 118, 126, 128, 130, 132, 134-135, 137, 144-148, 150, 153-154, 156
 Lee, C. H., 34, 76, 128, 134
 Lee, J. E., 53, 132, 144-145, 150, 154
 Lee, M-H, 134
 Lee, P.J., 134-135, 146, 148, 156
 Lee, S.-Y., 130, 132, 134, 137, 147
 Lee, S.J., 132
 Lee, Y., 126, 134, 153
 Lei, M., 129
 Leighton, C., 144
 Leonard, C.M., 133
 Lespinats, S., 146
 Lev Gor'kov, 116
 Levenson, C.W., 142, 149, 151
 Levine, L.H., 131
 Levy, J., 146
 Lewis, G., 137
 Leyraud, N.D., 127
 Li, C., 140, 149
 Li, D.S., 132
 Li, D.W., 132, 135-136
 Li, J., 132, 134, 137
 Li, L., 132
 Li, Lu, 127
 Li, P., 131, 146
 Li, Q., 138, 144
 Li, R., 137
 Li, S., 127
 Li, W., 132
 Li, X., 154
 Li, Z. Q., 131, 143
 Li Calzi, S., 132
 Liang, R. X., 134-135, 148
 Liang, W., 18, 132
 Lima, E.C. de O., 131
 Lin, Cp., 148
 Lin, M.Z., 136
 Lin, Y., 146
 Lin, C.Y., 134
 Lippincott-Schwartz, J., 136
 Litterst, F.J., 131
 Liu, B.Z., 127
 Liu, C., 129, 131
 Liu, J., 132, 140, 146
 Liu, M.-H., 127

- Liu, R. H., 130, 135, 144, 149
 Liu, S-C, 137
 Liu, T., 138
 Liu, X.T., 126, 132, 134
 Liu, Y., 133, 137-138
 Lloret, F., 133
 Logvenoc, G., 128
 Long, J. R., 125, 132-133, 141, 154, 159
 Long, M., 133
 Longo, M., 150
 Lonzarich, G. G., 135
 Looger, L.L., 133
 Lopez, X., 133
 Lorenz, B., 137
 LoSchiavo, M., 143, 146
 Lounsbury, A.W., 135, 153
 Lu, J., 128, 130, 132, 138, 143, 146, 151
 Lu, X., 131
 Luca, S., 140
 Luesch, H., 131-133, 136-137, 159
 Luke, G.M., 125, 130, 139
 Luke, W., 142
 Lukyanov, S., 136
 Lumata, L.L., 129, 138-139, 146-147, 149
 Lunney, E. A., 129, 152
 Luo, H., 146
 Luo, J.L., 138, 152
 Luongo, C.A., 127
 Läuchli, M.A., 137
- M**
- Ma, M., 132
 Macdougall, G.J., 130
 Machado, E., 126
 Macia, F., 132
 Mackenzie, A.P., 131
 Madiraju, M., 148
 Maginn, E.J., 133
 Maier, T.A., 129, 131-133
 Maiorov, B. A., 36, 126, 132-133, 136, 138-140, 146-147
 Mal, S.S., 133
 Mallick, S., 104, 146, 149
- Mandrus, D., 131, 138, 152
 Manfra, M.J., 127, 138
 Manley, S., 136
 Manning, P., 128
 Manousakis, E., 148
 Manson, J.L., 134
 Mao, C., 149
 Mao, H., 127
 Mao, Y., 146-147
 Mao, Z.Q., 138
 Mapolelo, M. M., 51, 130, 133, 143, 147, 149, 152
 Marcenat, C., 125
 Mareci, T.H., 126, 131-132, 159
 Markiewicz, W.D., 8, 129, 145, 147, 150-151, 156
 Markwick, P., 133, 135
 Marshall, A.A., 141
 Marshall, A. G., 126, 129-133, 135-154, 156
 Martin, J.W., 130, 143
 Martin, L.W., 137
 Martin, R.M., 126
 Martinelli, A., 127
 Martinez-Lillo, J., 133
 Martovetsky, N.N., 132
 Masad, I. S., 142, 148
 Masiello, C.A., 144
 Maslov, D., 153, 159
 Mason, K., 130
 Masson, P.J., 127
 Masuhara, N., 134
 Mathias, J.D., 133, 137, 150
 Matsubayashi, K., 131
 Matsuo, A., 134
 Matsuo, T., 142
 Matthew, S., 56, 133, 136
 Matthews, S., 133
 Matutes-Aquino, J.A., 126
 May, I., 127
 McCamey, D. R., 27, 133, 137, 147
 McCammon, C.A., 150
 McClellan, K.J., 130, 142, 153
 McCleskey, T., 146
 McDonald, R. D., 17, 125, 127, 133, 135-136
 McGavin, J., 140
 McGill, S.A., 137, 140, 142, 145, 147, 150, 152
- McGraw, T., 133
 Mcguire, M.A., 131, 138, 152
 McIntosh, D.G., 143-144
 McKenna, A.M., 133, 144, 147, 149, 151, 153-154
 McKeown, M.R., 136
 McKinney, S.A., 133
 Mcloughlin, S.M., 152
 McMorrow, F.D., 137
 McNeill, S.A., 133, 154
 McRea, D., 151
 McTigue, M., 129
 Meickle, T., 133
 Meicle, T., 136
 Meisel, M.W., 134-135, 145, 153, 159
 Mendels, P., 138
 Meng, D., 132
 Menjoge, A.R., 133, 135, 147
 Menon, R., 138
 Merbach, A.E., 126
 Merdrignac, I., 147
 Merz, K.M., 137, 159
 Mesot, J., 137
 Meyer-Baese, A. M., 133, 139, 146
 Meyer-Baese, U.H., 129
 Michael, 12, 73, 100, 108, 118, 147, 156
 Michaelis, V., 125
 Mielke, C. H., 125, 135-136
 Migliori, A., 8, 126, 134-136, 139, 149-150
 Milios, C.J., 128, 130
 Milla, K., 130
 Miller, G.E., 128
 Miller, J.R., 132-133
 Mills, F.D., 125, 132
 Miranda, E., 125, 138-139
 Mironov, O.A., 128, 141, 153
 Mishra, V., 126, 133
 Misra, R., 133, 154
 Misra, S., 133, 147
 Mitchell, J.F., 130, 143-144
 Mitchell, J.N., 136
 Miura, M., 36, 147
 Miyashita, S., 133
 Mohny, S.E., 127
 Molina, D., 129

Molinski, T.F., 76, 127
 Monson, G., 136
 Mookherjee, A., 135, 141
 Moomaw, E.W., 133
 Moon, B.H., 134
 Moore, J.D., 134
 Moraes, S., 129, 147
 Mori, H., 131
 Mori, T., 133
 Morley, G. W., 27, 133, 137
 Morley, G.M., 147
 Moses, D., 138
 Moskal, J.R., 141, 143, 148, 153
 Motowidlo, L., 134
 Moulton, W.G., 130, 143-144, 146
 Mounce, A.M., 134
 Moussatche, P., 133
 Movshovich, R., 126
 Mueller, R., 135
 Mui, S., 134
 Mukhopadhyay, S., 134
 Mulders, N., 126, 134
 Mullins, O.C., 136
 Murata, Y., 131
 Murphy, C.S., 131, 133, 136, 138
 Murphy, T.P., 126, 129, 135, 137, 142, 150
 Murray, D.T., 140, 147-148
 Murugesu, M., 130, 143
 Musfeldt, J.L., 134, 137, 152, 154
 Muttalib, K.A., 133, 135
 Muzioł, T., 49, 80, 134
 Myers, D., 150
 Myers, R.J., 138
 Myronov, M., 128

N

Nachtrab, W.T., 132, 134
 Nagler, S.E., 135
 Nair, S.S., 150
 Nakano, M., 128, 143
 Nakatsuji, S., 134, 142
 Nakotte, H., 125
 Namdas, E.B., 138
 Nanok, T., 134
 Nath, S., 134

Nayak, C., 128
 Neese, F., 50
 Nellutla, S., 126, 130, 133, 138, 144
 Nelson, C. T., 132
 Nelson, R.K., 136
 Neuberger, T., 45
 Neumeier, J.J., 139
 Neves, A., 137
 Nguyen, D.N., 134
 Nguyen, H., 148
 Ni, D., 140, 148
 Ni, N., 134, 137
 Nie, S., 132, 134, 137
 Niedoroda, A.W., 140-141
 Nieto, I., 134
 Nikolaev, E.N., 148
 Nikolaeva, A., 130
 Nilsson, C.L., 141, 143, 148, 150, 152-153
 Nimalendran, R., 131
 Ning, F., 125
 Ninios, K., 125, 139, 148
 Nishino, M., 133
 Nittler, L.R., 151
 Noh, D.Y., 131
 Normand, B., 137
 Novotny, M.A., 137
 Nowacek, D., 137
 Noyes, P., 128, 145, 147-148, 150-151
 Noyes, P.D., 128, 147
 Ntai, I., 132
 Nunes, E. da S., 131

O

O, K. K., 149
 Oates, William, 156-157
 Oca-Cossio, J.A., 127
 Odom, A.L., 127, 141, 157
 O'Farrell, E.C.T., 134
 Oh, S., 134
 Oh, Y.S., 131
 Ohmichi, E., 24
 Olenych, G.S., 131
 Ong, N.P., 127, 148
 Oniciuc, L., 129

Ono, T., 128, 142
 Oomens, J., 141
 Oosawa, A., 137
 Opeil, C.P., 135
 Opella, S.J., 134
 Orendáč, M., 22, 70, 134
 Orendáčová, A., 22-23, 70, 134
 Orignac, E., 137
 Osborn, R., 142, 153
 Ostrovski, S., 137
 Ottaviano, L., 135
 Overton, J.M., 151
 Ozarowski, A., 50, 126, 133-134, 136-137, 145, 148
 Ozarslan, E., 133

P

Padgett, K.R., 132
 Padmanabhan, M., 129, 134, 142, 148-149
 Paduan, A., 134
 Paduan-Filho, A., 127, 138
 Page, R.C., 134
 Paik, S.-Y., 147
 Painter, T.A., 126, 134, 139
 Pajerowski, D. M., 134-135, 145
 Palenzona, A., 127, 135
 Palevski, A., 135
 Palm, E.C., 126, 129, 135, 142
 Palmstrom, C.J., 127
 Palza, H., 130
 Pamidi, Sastry V., 157
 Pan, W., 132
 Pan, X. Q., 132
 Panagopoulos, C., 148-149
 Pankov, S., 148
 Pantea, C., 134, 136
 Papaefstathiou, G.S., 130
 Parekh, M.B., 126
 Park, H., 137
 Park, J.-H., 30, 129, 135, 142
 Park, J.G., 134, 148
 Park, S., 131
 Parker, G.J.M., 62
 Parks, C., 134
 Parra-Vasquez, A.N.G., 136

Parsons, S., 130
 Pasquali, M., 136
 Passacantando, M., 135
 Paster, J., 148
 Patel, U., 134
 Pati, M., 129
 Paul, D.K., 136
 Paul, V. J., 131-133, 136-137
 Pawlicki, A., 153
 Pearton, S.J., 159-160
 Peng, L., 134
 Peralta, R.A., 137
 Perebeinos, V., 136
 Perez, J.M., 134
 Perfit, M.R., 146
 Periasamy, A., 128, 136
 Perlepes, S.P., 130
 Peru, K.M., 130, 143
 Peterson, E., 149
 Petrovic, C., 135
 Pfeiffer, L.N., 127, 132, 137-138, 150
 Phelps, L., 130
 Pickard, K.P., 147
 Pilla, S., 135
 Pines, D., 126
 Pishko, G.L., 132
 Piston, D.W., 131, 135
 Pletnev, V.Z., 136
 Plocinski, P., 148
 Poblet, J.M., 133
 Poduslo, J.F., 131
 Pointer-Keenan, C., 154
 Polfer, N., 152, 160
 Polfer, N.C., 160
 Polyanskii, A.A., 128
 Polyanskii, A.A., 34, 131, 135, 138, 146, 148, 152
 Pomerantz, A.E., 136
 Pop, M.M., 105, 129
 Popovic, D., 8, 130, 148-149, 154, 257
 Port, M., 126
 Porter, C.C., 135
 Portugall, O., 136
 Pramudya, Y., 148
 Preamplume, G., 144
 Purcell, J. M., 129-130, 133, 135-136, 141, 144, 147, 149
 Purcell, K.M., 135, 154
 Putti, M., 135, 152

Q

Qian, C., 135, 142, 148
 Qin, H. J., 130, 140, 148-149
 Qiu, Y., 130, 138, 151
 Qu, D.-X., 127
 Quenzer, T.A., 129
 Quijada, R., 130
 Quinn, J.P., 143-144

R

Rachi, T., 131
 Rahimi, P., 136, 147
 Rai, R.C., 137
 Raicevic, I., 144, 148, 154
 Rajagopalan, M., 148
 Rajagovindan, R., 126
 Rakhmievitch, D., 135
 Ramachandran, V., 130, 134
 Ramaswamy, K., 134
 Ramesh, R., 137
 Ramos, M., 136
 Ran, Y., 133
 Rasheed, H., 141
 Ratcliff, W., 130
 Rawlings, R., 149
 Ray, A., 136
 Ray, K., 145
 Reddy, C.M., 136
 Reddy, K.R., 140
 Reddy, K.S.M., 127
 Redler, G., 135, 148
 Redzic, J.S., 135
 Reedijk, J., 154
 Reilly, 125, 127
 Reitze, D.H., 145, 154
 Ren, Z.A., 131
 Reno, J.L., 137
 Reyes, A.P., 126, 129-131, 134, 138-139, 143-144, 146-149
 Rezayi, E.H., 127-128, 130
 Rich, N.J., 142, 151
 Richard, M. G., 29
 Richards, N.G.J., 133

Riggs, S.C., 22, 125, 130-131, 135, 149
 Righter, K., 127, 135, 149
 Rikvold, P.A., 126, 133, 135, 137, 148-149, 152, 157
 Riley, S., 144
 Rinzler, A.G., 160
 Riss, O., 135
 Rizzo, M.A., 135
 Robb, D.E., 152
 Roberts, T.M., 138
 Robinette, S.L., 131, 138, 141, 152
 Rocca, J., 131
 Roche, P.M., 136
 Rodgers, R. P., 129-131, 133, 136, 143-144, 147, 149, 151-152
 Rodgers, R. P., 157
 Rodrigues, D. Jr., 135
 Rogado, N., 137
 Rogers, E.W., 76, 127
 Roje, S., 131
 Romain, N., 131
 Ross, C., 133, 136
 Rossini, A.J., 44
 Rotundu, C., 125
 Roush, W.R., 128
 Ryan, D.H., 22
 Rønnow, M.H., 137
 Rüegg, Ch., 137

S

Saarela, V., 129
 Sachi-Kocher, A., 149
 Sachs, M., 135
 Sahanggamu, P., 150
 Saito, S., 137
 Sales, B.C., 131, 138, 152
 Salmon, L., 135
 Salters, V.J.M., 127, 146, 149-150
 Salters, Vincent, 157
 Samarth, N., 127
 Sambandamurthy, G., 138
 Sambanis, A., 127
 Samulon, E., 135, 145, 149
 Samulon, E.C., 135, 149
 Samwer, K., 131

PUBLICATIONS & ACTIVITIES INDEX

- Sanders, M., 135, 154
 Sandim, H.R.Z., 139
 Sandler, N., 128, 149
 Sandoval, F.J., 131
 Sankaran, S., 149
 Santillan, C., 126
 Sarntinoranont, M., 131-132
 Sarrao, J.L., 126, 129-130
 Sarsfield, M.J., 127
 Sasagawa, T., 148
 Sastry, P.V.P.S.S., 134
 Savici, A.T., 135
 Savov, I.P., 149
 Sawa, H., 131
 Scalapino, D.J., 126, 129, 132-133
 Schaefer, M., 141
 Schenk, G., 137
 Schepkin, V. D., 59, 142, 149, 151
 Schirber, J.E., 24, 135
 Schlottmann, P., 6, 129, 135, 142, 153-154, 157
 Schlueter, J.A., 127, 134
 Schmidig, D., 76, 128
 Schmidt, K.P., 135
 Schmiedeshoff, G.M., 135
 Schroder, P., 144
 Schuur, E.A.G., 137
 Schwartz, J., 126-127, 132, 134, 136-137, 143-144, 149
 Schwartz, M. E., 143
 Schweitzer, K., 61
 Schwenk, K., 133
 Schäfer, M., 135, 141
 Scott, B.L., 127, 137
 Scott, E.W., 76
 Sebastian, S. E., 18, 134-135, 142, 153
 Sedláková, L., 134
 Seeber, B., 132
 Sefat, A.S., 131, 138, 152
 Seidel, A., 136
 Selcuk, S., 136
 Selesnic, S.D., 125
 Selvamanickam, V., 127, 129, 146
 Sen, G., 136
 Sengupta, P., 134
 Seok, E., 149
 Sergey Bud'ko, 6
 Serquis, A., 136
 Serrano, G., 136
 Seth, R., 151
 Severino, P.C., 137
 Shabani, J., 136
 Shah, D., 133
 Shaner, N.C., 136
 Shapiro, M.C., 135
 Sharma, M., 130, 140, 148-149
 Sharma, P.A., 131
 Sharma, R., 136
 Sharp, K., 136
 Shatruck, Mykhailo, 157
 Shaver, J.A., 136
 Shayegan, M., 129, 134, 136, 142, 148-149, 153
 Shcheglov, A.S., 136
 Shcherbo, D., 136
 Shefler, S., 135
 Sheikin, I., 128
 Shen, T.M., 136, 143-144, 149
 Sheng, X., 150
 Sheng, Z., 132
 Shepherd, T.M., 136
 Sheppard, D., 136
 Sheppard, W.R., 147
 Sheridan, C.M., 132
 Sherline, T.E., 128, 142
 Sherman, D.H., 136
 Sherwin, M.S., 137
 Shetty, K.K., 130, 133, 149
 Shi, X., 149
 Shim, D., 149
 Shiohara, Y., 147
 Shirai, N., 104, 149
 Shoenberg, D., 17
 Showalter, S.A., 133, 135
 Shtengel, G., 136
 Si, Q., 131
 Sideris, P.J., 129, 142
 Simmerling, C., 129
 Simon, P., 128
 Simon, S.H., 28, 126, 130, 138
 Simpson, N.E., 127
 Singh, S., 154
 Singh-Bhalla, G., 136
 Singletary, S., 144
 Singleton, J., 133, 136, 138, 152
 Siri, A.S., 127
 Skelton, B.W., 126
 Smeibidl, P., 126, 134
 Smirnov, A.I., 138
 Smirnov, D., 134, 137, 145, 149
 Smirnov, I.Yu., 128, 141, 153
 Smith, B.E., 127
 Smith, B.J., 126
 Smith, D.F., 130, 136, 143
 Smith, D.L., 127
 Smith, J.C., 127, 152
 Smith, J.M., 134
 Smith, R.S., 144
 Smithyman, J., 134, 148
 Smyth, D., 128
 Snyder, A., 136
 Snyder, D.A., 153
 Solomon, G., 145
 Solovieva, E.A., 136
 Son, K.I., 131
 Song, H., 136-137, 149
 Song, H.H., 149
 Soraya, S., 136
 Sosin, S.S., 138
 Soti, F., 131
 Spande, T.F., 131
 Spencer, M.J., 131
 Srivastava, A., 136
 Stachowiak, P., 134
 Stadler, M., 131
 Stahn, J., 137
 Staley, N.E., 138
 Stamatatos, T.C., 135, 148
 Stan, L., 138
 Stanford, L. A., 133
 Stanisz, G.J., 136
 Stanton, C.J., 134, 143
 Starch, W., 148
 Stegen, Z., 135, 149
 Stein, D.G., 151
 Steinbach, P.A., 136
 Steindel, P., 129
 Steindler, D.A., 160
 Stenson, A.C., 144
 Stepanov, B., 128
 Stern, C.R., 149
 Sternin, E., 125
 Stewart, G.R., 131, 160

Stewart, M., 138
 Stillwell, R., 23, 129, 142
 Stoll, S., 136
 Stormer, H. L., 143
 Stroe, I., 134, 136
 Sudheendra, U.S., 140
 Sughrue, W., 136
 Suh, S., 149
 Sullivan, N. S., 130, 134-135,
 137, 160
 Sun, C., 134
 Sun, Y., 128, 136
 Suslov, A., 128, 135-136, 141,
 149, 153
 Suslov, A.V., 128, 136, 141, 153
 Sutherland, M.L., 134, 142
 Suzuki, Y., 139, 150
 Sweeney, C.A., 127
 Sykora, R.E., 144
 Sytcheva, A., 127, 138
 Szpoganicz, B., 137
 Szymańska, I. B., 49, 80, 134

T

Taillefer, L., 127, 140
 Takahashi, S., 137
 Takano, Y., 125, 128, 131, 137, 142,
 144, 150
 Takita, M., 143
 Talathi, S.S., 126
 Talbot-Eeckelaers, C., 127
 Talham, D.R., 134-135, 160
 Tanabe, K., 147
 Tanaka, H., 128, 142
 Tang, J., 131
 Tanigaki, K., 131
 Taniguchi, H., 131
 Tannenbaum, R., 126
 Tanner, D.B., 139, 149, 153
 Taori, K. T., 56, 132, 137
 Tarantini, C., 127, 135, 138, 152
 Taratini, C., 132
 Taylor, M.M., 140, 142
 Taylor, R., 149
 Teclerian, A., 136
 Teitelbaum, G.B., 142

Tejada, J., 132
 Telser, J., 134, 137, 145, 150
 Terashima, T., 129
 Terenzi, H., 137
 Terletska, H., 150
 Thaker, R.W., 136
 Thelwall, P.E., 136
 Theriaque, D., 133
 Thielemann, B., 137
 Thieme, C.L.H., 137
 Thierry, G., 147
 Thomas, H. M., 132, 144
 Thomas, P.M., 150
 Thompson, J.D., 126
 Thompson, J.R., 129, 147
 Thompson, K.J., 137
 Thompson, S.H., 137
 Tibbetts, N.J., 104, 150
 Tipping, E., 48
 Tipton, J. D., 132, 137, 139, 144-
 147, 150-152
 Toby, B.H., 130
 Tokoro, H., 133
 Tokumoto, T., 142, 147, 150
 Tokunaga, M., 134
 Tomkowicz, Z., 137
 Tomonaga, M., 142
 Tompsett, D.A., 134, 142
 Toplosky, V.J., 146, 150
 Torikachvili, M. S., 21, 137
 Toth, J., 42, 126
 Towler, S., 133
 Tozer, S.W., 126, 129, 131, 135, 137,
 142, 154, 157
 Tran, H., 150
 Tran, J. C., 132, 144-145, 150
 Traylor, R.K., 144
 Trebosc, J., 130
 Tremaine, D.M., 150
 Trociewitz, U.P., 136-137, 143-147,
 149-151
 Trombe, J.-C., 138
 Tropeano, M., 127
 Trugman, S.A., 135-136
 Truong, M.L., 140, 142, 150
 Tsien, R.Y., 136
 Tsui, D.C., 132, 138
 Tsujii, H., 125, 137, 144, 150

Tsukada, I., 126
 Tselik, A.M., 138
 Tsybin, Y.O., 129
 Tugarinov, V., 136
 Tung, L.-C., 128, 134, 137, 143, 150
 Turnbull, M.M., 131
 Turner, B.L., 140
 Turrioni, D., 135, 148
 Tutuc, E., 129

U

Ubrig, N., 136
 Uchiyama, K., 131
 Ueda, H., 150
 Ugurlu, O., 133, 146
 Uhrig, G.S., 135
 Uji, S., 129
 Ulloa, S.E., 128, 149
 Urbano, R. R., 138
 Usov, I.O., 140
 Uwatoko, Y., 131

V

Vafek, O., 11, 12, 150-151
 Vakili, K., 129
 Valeja, S.G., 151
 Valenti, R., 129
 Valla, T., 138
 Van Niekirk, D., 151
 Van Orman, J.A., 144
 Van Sciver, S.W., 130, 139, 143, 151,
 154, 157
 Van Tol, J., 27, 126, 128, 130, 133,
 137-138, 147, 151
 Vandenborne, K.H., 131, 160-161
 Vanderlaan, M., 40
 VanLandingham, J.W., 142, 151
 Varret, F., 133
 Vasenkov, S., 133-135, 147, 154
 Vassilyeva, O.Y., 126
 Vekhter, I., 126, 133
 Velasquez, J.E., 151
 Vellaicham, A., 144
 Vellaichamy, A., 132, 145

Veloro, A.M., 126, 129, 131
 Velos, J., 154
 Vemuri, B., 133
 Venkataraman, K., 137
 Ventura, G.T., 136
 Vergara, L.I., 134, 137, 154
 Verity, M.A., 131
 Verkhusha, V.V., 136
 Vernek, E., 149
 Vestergaard-Poulsen, P., 76, 128
 Vicente, C.L., 132
 Villali, J., 129
 Vilorio, O., 136
 Vincente, C.L., 132
 Vinokur, V., 128, 142
 Viouchkov, Y., 145, 150-151
 Vivanco, J.M., 131
 Vlad Dobrosavljević, 119
 Vladimirov, G., 148
 Vockley, J., 126
 Vold, R.L., 130
 Vollmar, B.S., 127
 Von Ortenberg, M., 136
 Vorontsov, A., 126, 133
 Voyles, P.M., 135, 138, 144



Wade, A., 137
 Walse, S.S., 137
 Walsh, R.P., 128-129, 132, 146,
 150-151, 157
 Walter, G., 8, 76, 126, 141, 154, 161
 Walter, K.M., 135, 137
 Wan, X., 127, 130
 Wang, B., 134, 137, 148
 Wang, C.H., 142, 153
 Wang, H., 146
 Wang, J., 151-152
 Wang, N.L., 138, 152
 Wang, X.R., 132, 134, 137-138,
 145, 151
 Wang, Xu., 151
 Wang, Y.-J., 128, 130, 134, 137-138,
 140-141, 143, 150-151, 153-
 154, 157
 Waterman, C.M., 136

Webb, A.G., 44
 Weber, H.W., 128
 Wei, J., 126
 Weickert, F., 125
 Weijers, H.J., 126, 128-129, 145,
 147, 151, 153-154
 Weijers, H.W., 126, 128-129, 145,
 151, 157
 Weiss, J. D., 128, 132
 Wells, P. A., 129
 Welp, U., 134
 Wen, H.H., 130, 144
 Wernsdorfer, W., 130, 133
 West, K.N., 132
 West, K.W., 127, 132, 137-138, 150
 Whangbo, M.-H., 134
 Whitaker, J., 128
 White, B. D., 139
 White, J.M., 154
 Wicker, B.F., 144
 Wiebe, C.R., 125-126, 130, 138-139,
 142, 146, 150-151, 157
 Wieczorek, W., 140
 Williams, B.S., 137
 Willis, J.O., 147
 Willit, J., 129, 142
 Wilson, R.M., 137
 Wilson-Muenchow, A.A., 142
 Winnard, K., 151
 Winter, L.E., 127
 Witwicki, M., 48, 137
 Wolf-Watz, M., 129
 Wolff-Fabris, F., 137, 152
 Wolfle, P., 133
 Wong, T., 132, 134
 Wosnitza, J., 17, 127, 134, 138
 Wu, B., 131
 Wu, C.-C., 137
 Wu, H.B., 128
 Wu, J. C., 129
 Wu, X.-G., 150
 Wu, Y.Q., 136



Xavier, F.R., 137
 Xi, X.X., 138, 144, 152

Xia, J. S., 130, 132, 134, 137, 145
 Xian, F., 147, 151-152
 Xiao, Z.L., 134
 Xie, Y., 127, 146
 Xin, Y., 129, 138, 146
 Xiong, P., 140
 Xu, A., 132, 145, 147, 150
 Xu, M., 136
 Xu, T., 126, 134, 139
 Xu, X.S., 137, 152
 Xu, Y., 138, 140



Yamamoto, A., 128, 130-132, 136,
 138, 143, 152
 Yamamoto, Y., 131
 Yan, J.-Q., 127, 140
 Yang, C.L., 127, 137
 Yang, E.-C., 132
 Yang, H., 128
 Yang, J., 131
 Yang, K., 11, 12, 126-128, 130,
 136, 138
 Yang, Kun, 157
 Ye, C., 134
 Ye, M., 140-141
 Ye, P.D., 136
 Yen, A. T., 133, 147, 152
 Yen, F., 137
 Yi, H.T., 130
 Yi, K., 138
 Yi, M., 128, 138, 140, 152
 Yildirim, T., 21
 Yin, L., 134, 137, 145
 Yin, M., 126
 Ying, Y.A., 138
 Ymamoto, A., 144
 Yoo, C.-D., 154
 Yoshida, Y., 128, 137, 142
 Yu, X., 129, 152
 Yuan, H.Q., 138, 152
 Yuan, Z.Q., 127, 138, 154
 Yuen, J.D., 138
 Yurchenko, V., 135

Z

Zachriah, C., 131
Zaliznyak, I. A., 138
Zapf, V.S., 32, 125, 127, 131, 134,
137-138, 152
Zaraisky, A.G., 136
Zehetmayer, M., 128
Zeleňák, V., 23, 134
Zeng, B.R., 138
Zhai, Y., 126, 134, 138, 152
Zhang, C., 134, 138, 148, 154
Zhang, F., 131, 135, 138, 141, 152
Zhang, H.-M., 129, 138-139, 141-
142, 152-154
Zhang, J., 132, 138
Zhang, L., 130, 138
Zhang, Y., 15, 129, 132
Zhang, Z., 132, 152
Zhao, W., 131
Zhao, Y., 11, 134
Zhao, Z.X., 131
Zheng, H., 130
Zheng, L.-M., 145
Zherlitsyn, S., 127, 138
Zhigadlo, N.D., 130
Zhoa, Z.X., 131
Zhou, H.-X., 125-126, 128, 130, 133,
138-140, 146, 150-152
Zhou, H.D., 126, 130, 138-139, 146
Zhou, H.X., 128, 138, 140, 152, 157
Zhou, J.-S., 127, 140
Zhou, S., 138
Zhu, H., 138
Zhu, L., 138
Zhu, P., 132
Zhu, Y., 135, 138, 144
Zhuang, C.G., 138, 144, 152
Zikos, G., 126, 138, 154
Zimov, S.A., 137
Zlobin, A.V., 135, 148
Zorko, A., 138
Zou, A., 129
Zuo, J., 136
Zvanut, M.E., 151
Zvanut, W.E., 137
Zvyagin, A.A., 127, 138
Zvyagin, S.A., 134, 138

1800 E. PAUL DIRAC DRIVE
TALLAHASSEE, FL 32310-3706

TEL: 850-644-0311
FAX: 850-644-8350
www.magnet.fsu.edu



Supported by:



NATIONAL HIGH MAGNETIC FIELD LABORATORY