

NATIONAL HIGH  
**M**MAGNETIC  
FIELD LABORATORY



2013–2017  
FINAL REPORT



## National High Magnetic Field Laboratory

DIRECTOR  
Gregory S. Boebinger

DEPUTY LAB DIRECTOR  
Eric Palm

CHIEF SCIENTIST  
Laura Greene

USERS PROGRAM, CHIEF OF STAFF  
Anke Toth

Proofread by  
ADMINISTRATIVE SPECIALIST  
Christina Wackes

PHONE NUMBER  
850-644-0311

This document is available in alternate formats upon request.  
Contact Anke Toth for assistance. If you would like to be added to our  
mailing list, please email [atoth@magnet.fsu.edu](mailto:atoth@magnet.fsu.edu)



# Table of Content

## **001 Director's Executive Summary**

## **006 Chapter 1 – Year at a Glance**

## **011 Chapter 2 – Laboratory Management**

- 012 2.1. Organizational Chart
- 015 2.2. External Advisory Committee
- 016 2.3. User Committee
- 017 2.4. Personnel
- 025 2.5. Diversity and Inclusion
- 030 2.6. Safety
- 035 2.7. Budget
- 047 2.8. Cost Recovery Report
- 048 2.9. Industrial Partners & Collaborators
- 060 2.10. Data Management

## **062 Chapter 3 – User Facilities**

- 063 3.1. User Program
- 064 3.2. UCGP and Other Additional Funding Opportunities
- 069 3.3. User Advisory Committee Report
- 082 3.4. User Safety Training by Facilities
- 085 3.5. Annual User Program Survey
- 088 3.6. User Facilities
  - 088 3.6.1. *Advanced Magnetic Resonance Imaging and Spectroscopy (AMRIS) Facility*
  - 091 3.6.2. *DC Field Facility*
  - 099 3.6.3. *Electron Magnetic Resonance (EMR) Facility*
  - 104 3.6.4. *High B/T Facility*
  - 110 3.6.5. *Ion Cyclotron Resonance (ICR) Facility*
  - 117 3.6.6. *Nuclear Magnetic Resonance (NMR) Facility*
  - 122 3.6.7. *Pulsed Field (PF) Facility*

## **128 Chapter 4 – Education & Outreach**

- 129 Education & Outreach
- 146 Conferences & Workshops
- 149 Broadening Outreach

## **155 Chapter 5 – In-house Research**

- 156 5.1. Magnets & Magnet Materials
- 176 5.2. Condensed Matter Science
- 185 5.3. Cryogenics Research Group
- 189 5.4. Geochemistry

## **191 Chapter 6 – Accomplishments & Discoveries**

- 192 Products of MagLab Users & Faculty
- 235 Honor & Awards
- 235 Ph.D. Dissertations & M.S. Theses

## **238 Final Report - No-Cost Extension**

## **Appendix I – User Facility Statistics**

## **Appendix II – User Facilities Overview**

## **Appendix III – Geographic Distribution**

## **Appendix IV – Personnel**

## **Appendix V – Postdoctoral Mentoring Plan**

## **Appendix VI – User Proposals**



# Director's Executive Summary



# Director's Executive Summary

## 2017 Year in Review

The National High Magnetic Field Laboratory had another **record number of users with 1,809 researchers, students, and technicians conducting experiments in 2017**. There were 480 principal investigators, 26% of whom were new to the Lab or the facility they were using to conduct research. About 24% of the MagLab's users who chose to identify were females and 7% identified as a minority.

The MagLab's research community continued evolving with 21% of the Lab's users performing experiments at our lab for the first time in 2017 and nearly half of the user community comprised of students and postdocs.

When asked to rate their experience, MagLab users are exceptionally positive. A user survey conducted in June continues to show overwhelming satisfaction:

- 94% satisfied with the performance of the facilities and equipment
- 96% satisfied with the assistance provided by MagLab technical staff
- 94% satisfied with the proposal process
- 96% satisfied with the availability of the equipment and facilities

After conducting research at the MagLab, users submit brief summaries of their experimental results. In 2017, users generated 425 reports across condensed matter physics, magnet science and technology, chemistry, and life sciences. All research reports will be released in the summer.

User research earned 408 publications in 2017, many in significant journals like *Science*, *Nature*, *Physical Review Letters*, *Energy Fuels*, *Analytical Chemistry*, and the *Proceedings of the National Academy of Sciences*.

## New Magnets

New instruments and ever-stronger magnets are an important part of the Lab's research ecosystem. From beginning to end, 2017 was filled with new magnet achievements that will facilitate the cutting-edge research of the future.

In the first quarter of 2017, the field compensation system for the **Series Connected Hybrid (SCH)** achieved a 1 part per million homogeneity over a 10 mm sized volume. Commissioning this magnet

system was the focus in 2017 with work on improving the cryogenic and electrical operational conditions and parameters, adjusting field uniformity and stability, demonstrating the NMR probes, and introducing an insert cryostat for condensed matter physics. Initial NMR and condensed matter user operations were begun at the end of 2017 and regular user operations will begin in early 2018.

On August 14, engineers at the National MagLab broke two world records with a 5 cm magnet coil made of high-temperature superconducting REBCO tape. This mini-magnet was designed with **no insulation**, allowing engineers to pack far more conductor into a small area. The coil reached 14.4 tesla inside a 31.2 tesla resistive magnet, breaking the **record for an HTS magnet operating within a background field** and achieving a **world record for the highest field in which a superconducting magnet has ever operated**. This new technique may be a path to design next generation magnets.

On August 21, just hours before the solar eclipse, the MagLab also regained a world record by producing **41.4T in a resistive magnet** with a 1-meter diameter and a bore size of 32 mm. This magnet will allow researchers access to intense magnetic fields that had only been available with hybrid magnets. The ability to rapidly sweep magnetic fields and easily reverse polarity will give users the speed and flexibility to explore the fascinating properties of quantum materials. The magnet cell is now being outfitted with a user platform and custom high-performance vibration isolation structure to prepare for user operations in 2018.

On December 8, the **32T all-superconducting magnet** also reached full field, culminating 8 years of work by MagLab engineers to create the highest-field superconducting magnet ever constructed. The magnet project was a public-private partnership with SuperPower (who produced the REBCO conductor) and Oxford Instruments (who developed the outer Nb<sub>3</sub>Sn and Nb-Ti coils). This accomplishment represents the beginning of a new era in high-magnetic field research at the MagLab, as it will allow users to perform experiments in stable, ultra-high superconducting magnetic fields. When moved to its new space in the millikelvin expansion and opened for user operations later in 2018, it will provide researchers with a unique

# Director's Executive Summary

tool to explore the quantum realm with greater depth than ever before.

MagLab researchers also made important advancements in designing a **superconducting joint** between two Bi-2212 round wires. The technique connects two wires without introducing any other material and results in near-zero resistance. The procedure is practical and compatible with the coil winding and heat treatments that are standard for Bi-2212 coil manufacturing, offering great promise for future applications, especially in nuclear magnetic resonance and particle accelerator magnets.

## User Facility Enhancements

In 2017, the Florida State University Vice President for Research, Gary Ostrander, announced that FSU would provide funding to construct a **short-stay facility for users** who travel to perform research at the MagLab. The new building will accommodate up to twelve guests and will feature a large, well-equipped kitchen/common area as well as collaborative space. Design was completed in late 2017 and construction is planned for 2018.

Across the National MagLab's seven user facilities, enhancements and upgrades were made in 2017 that improve the user experience and experimental environment. Among the enhancements: Construction was completed on the 1,600 ft<sup>2</sup> millikelvin expansion within the DC Field Facility. Supported by the FSU Office of Research, this new space features two magnet pits and copper-lined walls to reduce ambient RF levels. It will become the permanent home for the 32T superconducting magnet.

- A magnet-cooling-water heat exchanger was replaced and new, low-pressure differential filters were installed, improving the overall performance of the magnet cooling water system.
- Significant changes and improvements in high-field Far Infrared (FIR) instrumentation were made available for users in the DC Field Facility. The SCM3 FIR system received an upgraded light pipe system that greatly improves the signal-to-noise ratio for experiments in this system. A new FIR probe for use in the 35T resistive magnets was also built and tested, resulting in significant improvements in the signal-to-noise ratio for user experiments in the 35T resistive magnets.

- AMRIS installed a <sup>13</sup>C-optimized 10 mm cryoprobe at 600 MHz that, in combination with the Hypersense Dynamic Nuclear Polarization (DNP) polarizer installed last year, now enables real-time metabolic measurements in functioning cardiac tissue.
- A new multiplier chain was acquired for the EMR homodyne spectrometer, providing wider frequency coverage, enhanced sensitivity/dynamic-range, and greater flexibility when using the sources in the DC facility.
- The EMR group obtained a narrow-band source operating at 395 GHz as part of the group's development of DNP enhanced NMR capabilities at 600 MHz.
- A 1 mW 950 GHz source and mixer-detector will help the EMR group develop high-resolution electron paramagnetic resonance (EPR) capabilities in the new Series Connected Hybrid magnet.
- DNP efforts at 395 GHz are now part of a full-fledged solid-state Magic Angle Spinning (MAS)-DNP enhanced NMR user program. Major breakthroughs have also been achieved as part of our efforts to develop a solution state Overhauser DNP capability at 600 MHz.
- A Bruker console and three high-performance NMR probes for the 36T SCH magnet were designed and constructed in 2017.
- Planning was completed for modifications to the High B/T facility's roof hatches above the electromagnetically shielded rooms. The new design will automatically open in the case of a magnet quench.
- Tunnel diode oscillators are being tested at the High B/T facility for their high sensitivity and low power dissipation.
- A high-resolution piezo-dilatometry technique was developed on the 65T pulsed magnet system, providing high sensitivity and the ability to sense crystallographic directions normal to the applied magnetic field, complementing the existing optical Fiber Bragg Grating dilatometry.
- The pulse echo ultrasound technique launched in 2016 was further improved and implemented in the Pulsed Field Facility's user program, allowing the investigation of field-induced phase transitions and symmetry changes.

# Director's Executive Summary

- In collaboration with experts from the Los Alamos National Laboratory, the design phase for the Pulsed Field Facility's 1.43 GW power generator upgrades was completed in 2017.
- A new technique within the Ion Cyclotron Resonance Facility was implemented that can determine the precise molecular makeup of antibodies in a sample from far lower concentrations (10 times lower) than is possible with present-day conventional methods, effectively identifying biomarkers at a much higher sensitivity level.

## Accolades & Awards

In 2017, both MagLab faculty and users were recipients of prestigious awards, including:

- Greg Boebinger, Director of the National High Magnetic Field Laboratory, who was named a fellow of the American Academy of Arts and Sciences, one of the country's highest professional honors.
- Vivien Zapf, a MagLab researcher, who was named a fellow of the American Physical Society (APS) along with ten external MagLab users.
- Efstratios Manousakis, who was named a fellow of the American Association for the Advancement of Science (AAAS) for his contributions to innovation, education, and scientific leadership.

## Dedication to Education, Diversity, & Safety

In 2017, the MagLab continued to reach over 10,000 K-12 students annually through classroom programs, 69% of which occurred at Title I schools. Five middle school summer camps hosted 90 unique students, 86% from underrepresented groups, and the MagLab Middle School Mentorship Program hosted its largest group for the third consecutive year - 20 students from across Leon and Gadsden counties in Florida.

UF MagLab and MagLab-affiliated professors recognized the *2017 United Nations' International Women and Girls in Science Day*, by organizing an event called *Talk Science with Her*. Eight female scientists (including two MagLab faculty) from across career levels and a wide variety of scientific disciplines spoke with a hundred attendees who asked questions to discover more about the variety of research that scientists are pursuing.

The MagLab hosted more than 8,000 visitors at our annual Open House once again, this year with a theme of "Science and the Movies". In addition, a special virtual reality experience was developed in partnership with the FSU College of Motion Picture Arts that showcased to thousands of people at the Smithsonian Museum of American History during the "ACC Festival of Innovation" in October.

Expanding on the success of its summer and winter schools for early career scientists, the MagLab hosted a new advanced EPR school in 2017. This two-day, hands-on course provided 26 graduate students and postdocs an opportunity to learn and practice various EPR techniques on the state-of-the-art spectrometers at the MagLab.

In 2017, MagLab staff gave about 275 lectures, talks, and presentations across 14 foreign countries and over a dozen states. The Diversity Committee funded 12 professional development travel requests and four dependent care travel grants in 2017. The MagLab's headquarters location was also named a *Family Friendly Workplace* by the City of Tallahassee and a new networking program for women faculty at the MagLab was launched.

Florida State University's Environmental Health and Safety Department (EH&S) continued providing additional leadership for safety at the MagLab in 2017. This year, the EH&S Director and Associate Director visited the MagLab's High B/T and AMRIS Facilities at UF to foster more coordination and collaboration among the FSU and UF MagLab facilities and safety teams.

In 2017, the MagLab directed its safety reserve funds to update the Safety Clearance User Database, used for lockout/tagout/verification of hazardous energy, and the design and installation of a new resistive-magnet-cell voltage disconnect verification system.

As part of the MagLab's continued evolution of its Integrated Safety Management program, an upgraded Task Hazard Analysis (THA) process and worksheet was implemented in 2017. This revision takes into account both the worker's familiarity with the task and the complexity of the task in order to provide a more accurate analysis of the hazards to be addressed.

The MagLab was able to practice its Natural Disaster Preparedness Emergency Action Plan (EAP) during 2017's active hurricane season. Six days prior to Hurricane Irma impacting north Florida, the MagLab began having daily meetings to discuss weather

# Director's Executive Summary

updates, preparedness, and coordination with FSU leadership. Departments reviewed their specific preparedness plans for possible shut-down and initiated actions to secure facilities and equipment as Irma approached. Critical areas of concern, such as cryogen supplies, fuel for backup generators, and overall security and safety at the MagLab, were addressed. Current and scheduled users were notified of possible travel disruption issues and were provided information concerning sheltering in place, rescheduling magnet time, evacuation plans, and local emergency services.

## The Bright Future Ahead...

New magic angle spinning probes are being developed for NMR in the Series Connected Hybrid Magnet system. These probes are expected to open a floodgate for research on proteins that are not water soluble, including membrane proteins. Completion is expected in late 2018.

The 75T Duplex magnet, housed at the Pulsed Field Facility, is also nearing commissioning. This magnet will consist of two nested coils driven by two separate capacitor-bank circuits, located in a new cell with two isolation switches and a new user platform built next to our 4MJ capacitor bank.

The hosting of user experiments on the new 32T all-superconducting magnet will provide a nearly 50% jump in magnetic fields available from the MagLab's suite of superconducting magnets. It will increase magnet hours available for a wide range of user experiments that require ultra-quiet environments or extra-long times at peak magnetic field.

## For More Information...

Please explore the detailed information available in the individual chapters of this 2017 Annual Report or access our website at <https://nationalmaglab.org/>.





# Chapter 1 – Year at a Glance

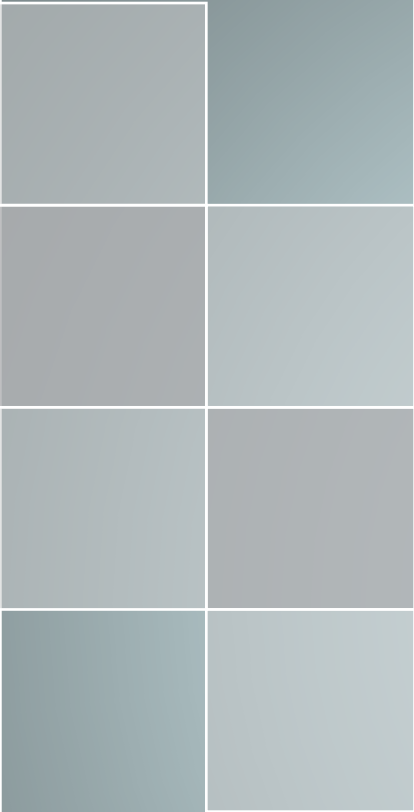

# WORLDWIDE USER COMMUNITY

## 2017 LAB STATS



In 2017, the MagLab's **1,809** users represented **173** universities, government labs and private companies in the United States and a total of **324** worldwide.

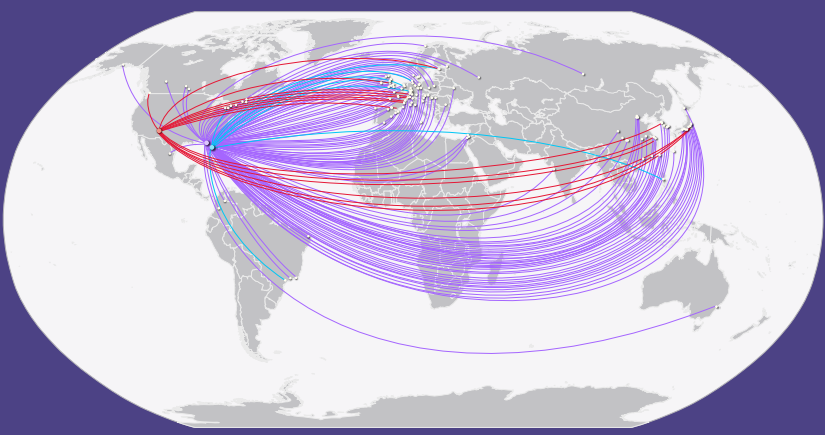
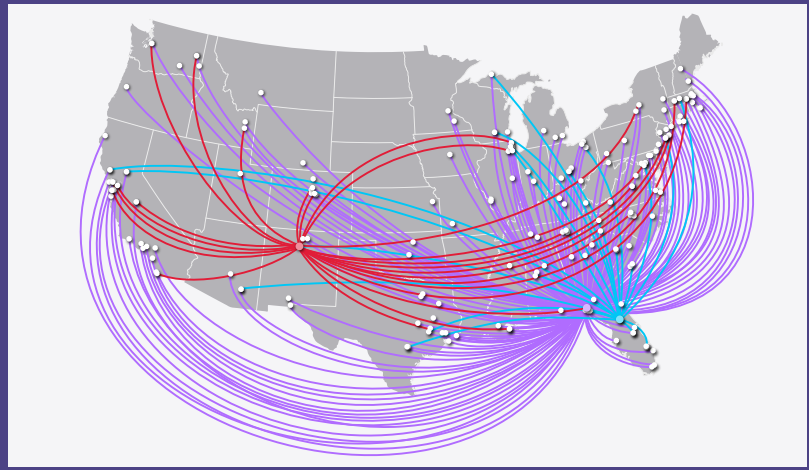

## USER DIVERSITY

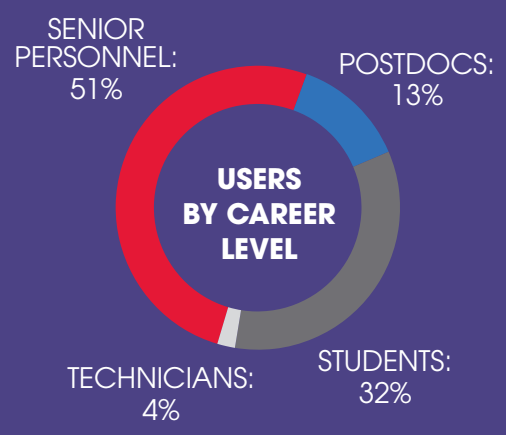

- DC FIELD - **583**
- PULSED FIELD - **137**
- HIGH B/T - **20**
- EMR - **165**
- NMR - **280**
- AMRIS - **339**
- ICR - **285**

**DOMESTIC INSTITUTIONS**

- 133 UNIVERSITIES**
- 20 GOVERNMENT LABS**
- 20 INDUSTRY**

**INTERNATIONAL INSTITUTIONS**

- 113 UNIVERSITIES**
- 25 GOVERNMENT LABS**
- 13 INDUSTRY**

**23% OF STUDENT USERS ARE FEMALE.**

**AND 23% OF POSTDOC USERS ARE FEMALE.**

## WHAT OUR USERS SAY

**94%**

of users were satisfied with performance of the facilities and equipment.

**96%**

of users were satisfied with the assistance provided by MagLab technical staff.

**94%**

of users were satisfied with the proposal process.

Data reflects external users only. All users were surveyed anonymously.

## 2017 USERS BY DISCIPLINE

The MagLab's interdisciplinary research environment brings scientists from a variety of disciplines to explore materials, energy and life.

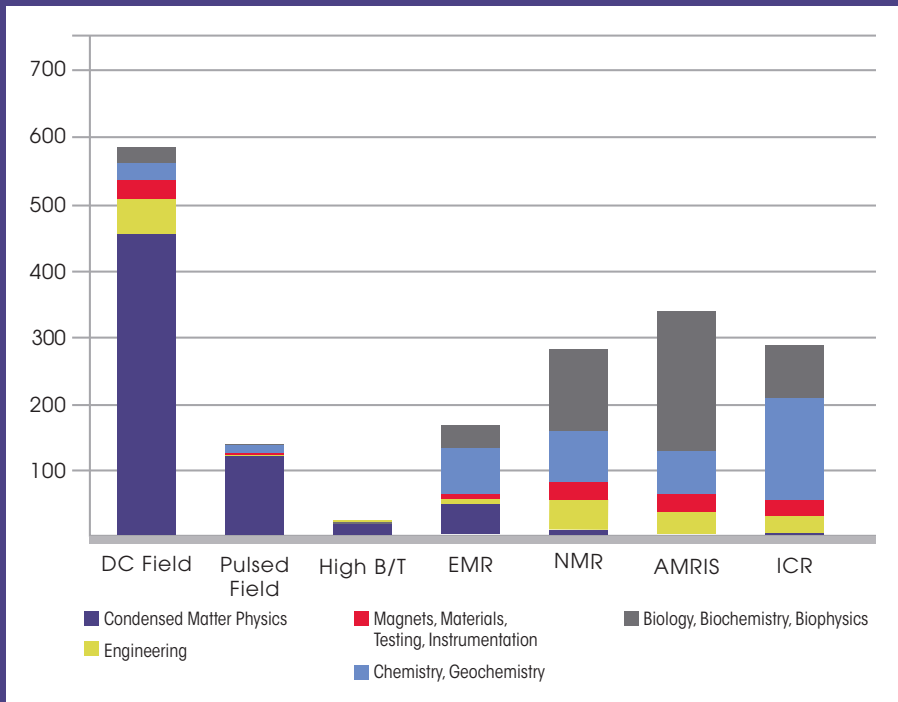

Thank you for being the best user research facility that I've had the privilege of working at! All the equipment we used on this trip was in perfect condition. The choice of instruments at the MagLab is very extensive, and they cover almost the entire spectrum of measurements.

**Hema C. P. Movva**

The University of Texas at Austin

As always thank you so much for your best-of-the-world facility and support.

**Fang Tian**

Pennsylvania State University

# RESEARCH INVESTMENTS

## FINANCIAL REPORT

**TOTAL BUDGET: \$53,491,652**

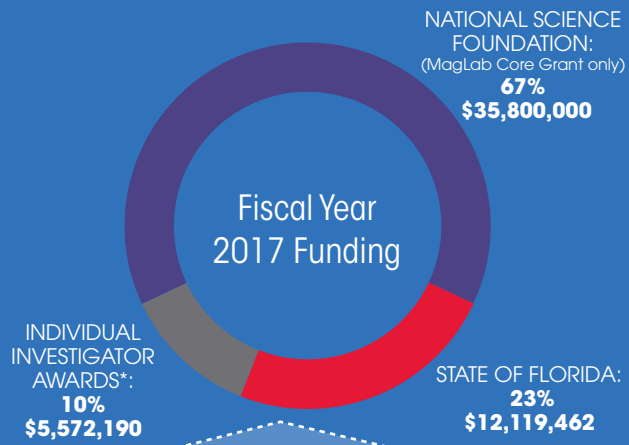

- Physics & Materials Research: **46%**
- Magnets, Materials & Engineering: **27%**
- Chemistry: **9%**
- Biology & Biochemistry: **7%**
- Management & Administration: **9%**
- Education/Diversity: **2%**

\*These are new 2017 awards from funding other than the NSF core grant and State of Florida that benefit the MagLab user program.

## NEW WORLD-RECORD MAGNETS

**New magnets are an important part of the lab's research ecosystem.**

These two world-record magnets will explore the quantum world with greater depth than ever before.

### 41.4 T RESISTIVE MAGNET

- 41.4 tesla copper-silver alloy & copper Bitter disks
- 32 mm bore 32 MW power supply

### 32 T ALL SUPERCONDUCTING MAGNET

- 32 tesla **YBCO**, niobium-tin and niobium-titanium
- 34 mm bore 33% stronger than previous record holder

The first high-field magnet to feature high-temperature superconducting YBCO.

## ECONOMIC IMPACT

THE MAGLAB ANNUALLY GENERATES

IN THE USA

**\$182 million** in economic output

---

more than **1,560 jobs**

OVER THE NEXT 20 YEARS, PROJECTED TO GENERATE

IN THE USA

**\$3.6 billion** in economic output

---

more than **31,000 jobs**

## PARTNERSHIPS

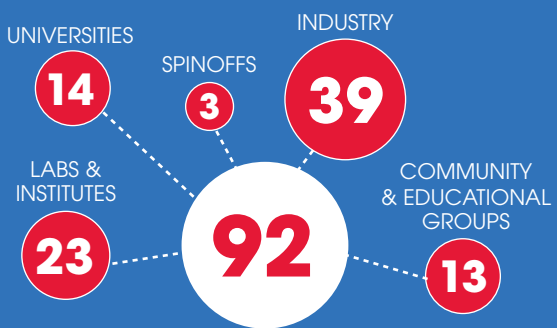

**Cross-Sector Partners**

RETURN ON INVESTMENT

**\$1** = **\$6.57**

INVESTED BY THE STATE = ECONOMIC ACTIVITY IN FLORIDA

# BUILDING THE STEM WORKFORCE

## ENGAGING THE COMMUNITY

**8,000** visitors walked the red carpet at the 2017 movie-themed Open House, **46%** of whom visited the lab for the first time.

**97** scientists engaged in outreach to **4,500** people.

**11,000** printed copies of *fields* magazine distributed in 2017 and nearly **6,000** *fields* page views online.

**2.1 MILLION** minutes of MagLab videos watched on our YouTube channel.

## ENGAGING STUDENTS & TEACHERS

More than **10,000** K-12 students participated in a tour or classroom outreach, **69** percent of whom came from Title I schools.

**5** middle school summer camps reached **90** students, **86%** from underrepresented groups.

**10** teachers participated in Research Experiences for Teachers, **80%** from Title I schools.

**250+** teachers attended MagLab presentations at science education conferences.

**35** high school and college students were interns at the MagLab.

## ENGAGING EARLY CAREER SCIENTISTS

**275** lectures, talks or presentations were given by MagLab staff across **14** countries and a dozen states.

**80** early career participants in MagLab Theory Winter and User Summer schools.

**800+** of the MagLab's 2017 users were postdocs or students.

## MAGLAB STAFFING

Personnel at FSU, UF & LANL includes employees funded by the NSF Core Grant or State of Florida.

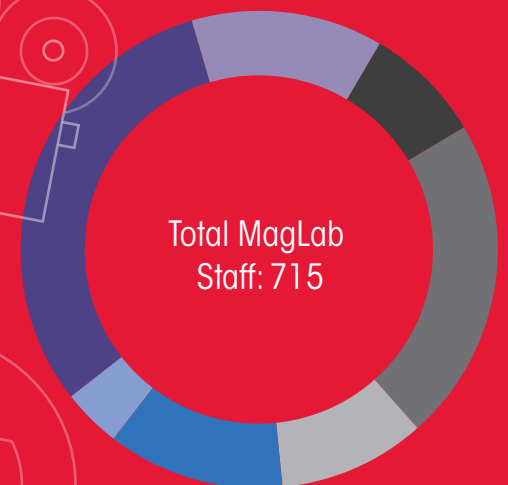

Senior Personnel: **220**  
Other Professional: **93**  
Postdoc: **56**  
Graduate Student: **162**  
Undergraduate Student: **63**  
Support Staff - Technical/Managerial: **94**  
Support Staff - Secretarial/Clerical: **27**

Postdocs, graduate students and undergraduate students make up **39%** of the staff.

**43%** OF UNDERGRADS

**41%** OF GRAD STUDENTS

**29%** OF POSTDOCS

ARE FEMALE



# Chapter 2 – Laboratory Management

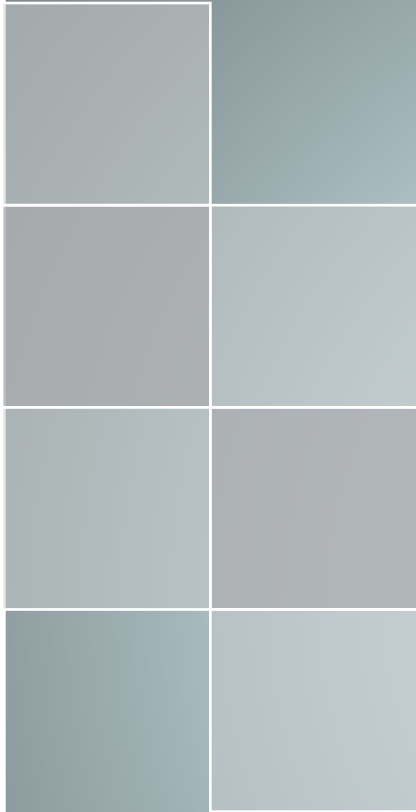

# Chapter 2 – Laboratory Management

## 2.1. Organizational Chart

The Florida State University (FSU), the University of Florida (UF), and Los Alamos National Laboratory (LANL) jointly operate the National High Magnetic Field Laboratory (NHMFL or MagLab) for the National Science Foundation (NSF) under a cooperative agreement that establishes the Lab's goals and objectives. FSU, as the signatory of the agreement, is responsible for establishing and maintaining administrative and financial oversight of the Lab and ensuring that the operations are in line with the objectives outlined in the cooperative agreement.

The structure of the MagLab is shown in the three figures below. **Figure 1** illustrates the external oversight and advisory committees, as well as the three

internal committees that provide guidance to NHMFL leadership.

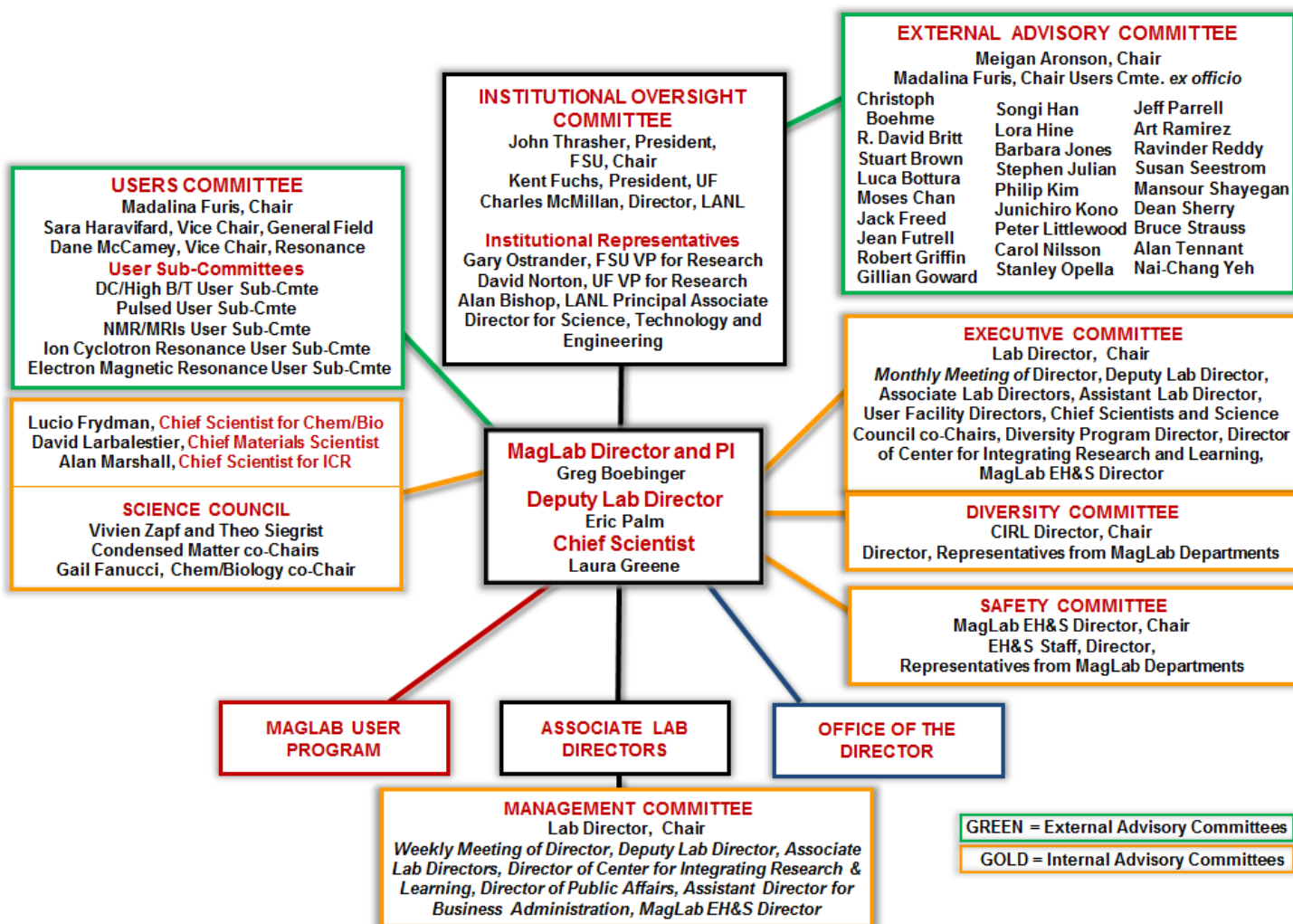

**Figure 1:** Advisory Committees of the MagLab, showing internal and external advisory committees (as of June 20, 2017).

**Greg Boebinger** is the Director of the MagLab and PI of the cooperative agreement. Together, the Director, Deputy Laboratory Director, **Eric Palm**, and Chief Scientist, **Laura Greene**, function as a team to provide management oversight for the Laboratory. The **Management Committee** — consisting of the Associate Lab Directors, Director of CIRL, Director of PA, EH&S

Director and the Assistant Director for Business Administration — meet on a weekly basis to discuss issues of importance across the MagLab. The **Executive Committee** meets on a monthly basis to discuss Lab-wide issues as well as program – specific issues.

The Lab's scientific direction is overseen by the **Science Council**, a multidisciplinary “think-tank” group

# Chapter 2 – Laboratory Management

of distinguished faculty from all three sites. Members are: Vivien Zapf (co-chair), Theo Siegrist (co-chair), Gail Fanucci (co-chair), Luis Balicas, Lance Cooley, Zhehong Gan, Neil Harrison, Stephen Hill, Kevin Ingersent, Jurek Krzystek, Joanna Long (ex officio), Ross McDonald, Amy McKenna, Mark Meisel, Albert Migliori (ex officio), Dragana Popovic, Ryan Rodgers, John Singleton, Stanley Tozer, Glenn Walter, and Huub Weijers as well as the four chief scientists: Laura Greene (Chief Scientist), Lucio Frydman (Chief Scientist for Chemistry & Biology), David Larbalestier (Chief Materials Scientist), and Alan Marshall (Chief Scientist for ICR).

Two external committees meet regularly to provide critical advice on important issues. The **External Advisory Committee**, made up of representatives from

academia, government, and industry, offers advice on matters critical to the successful management of the Lab. The **Users Committee**, which reflects the broad range of scientists who conduct research at the Lab, provides guidance on the development and use of facilities and services in support of the work of those scientists. These committees are further described below.

**Figure 2** shows the structure of the user program with its seven user facilities – DC Field Facility, Pulsed Field Facility, High B/T Facility, Electron Magnetic Resonance Facility, Nuclear Magnetic Resonance and Magnetic Resonance Imaging at Florida State University and at University of Florida and, Ion Cyclotron Resonance.

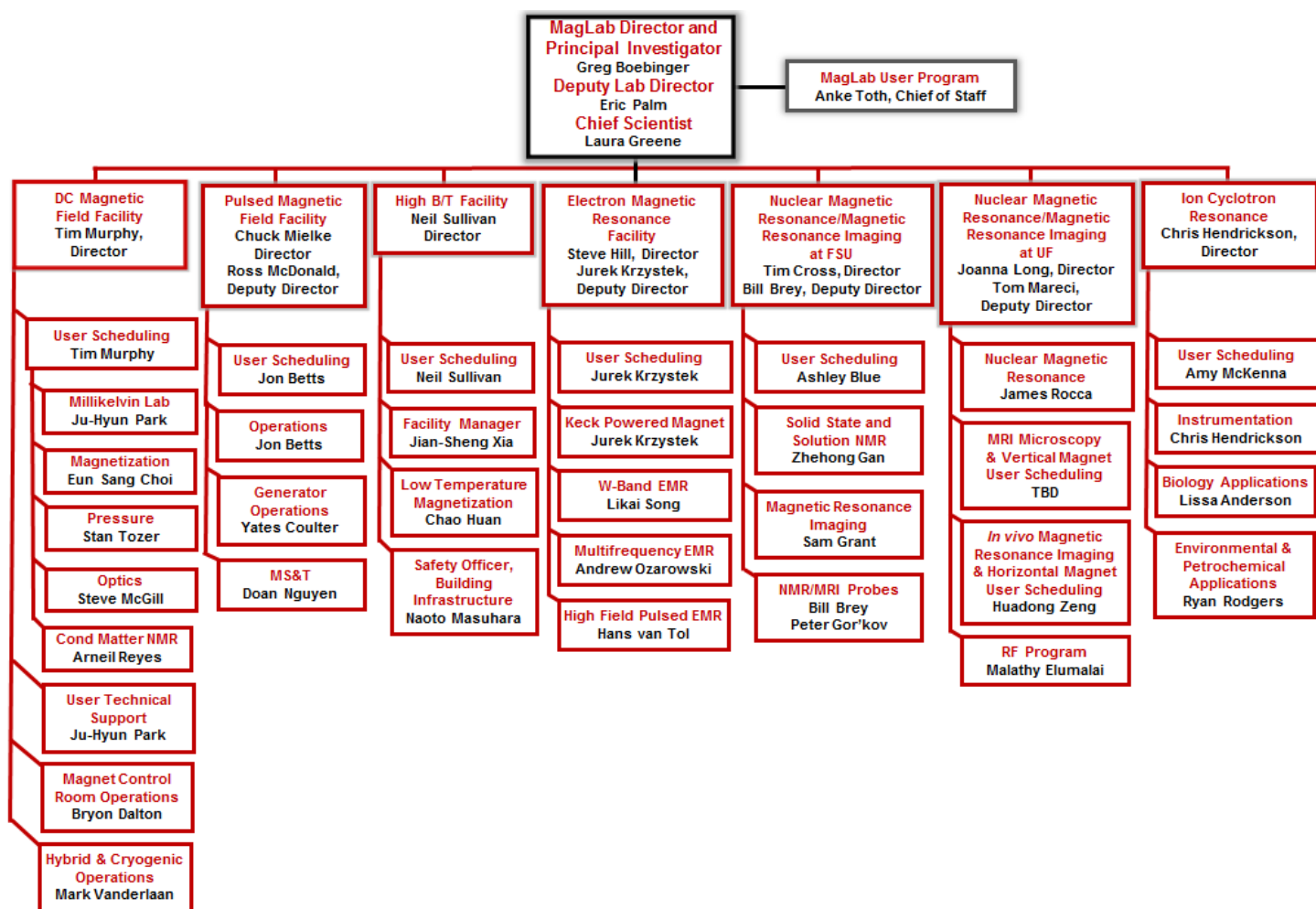

**Figure 2:** NHMFL User Program (as of June 20, 2017).



# Chapter 2 – Laboratory Management

Figure 3 displays the internal, operational organization of the Laboratory. It includes the seven

user facilities, all Associate Lab Directors as well as the Office of the Director structure.

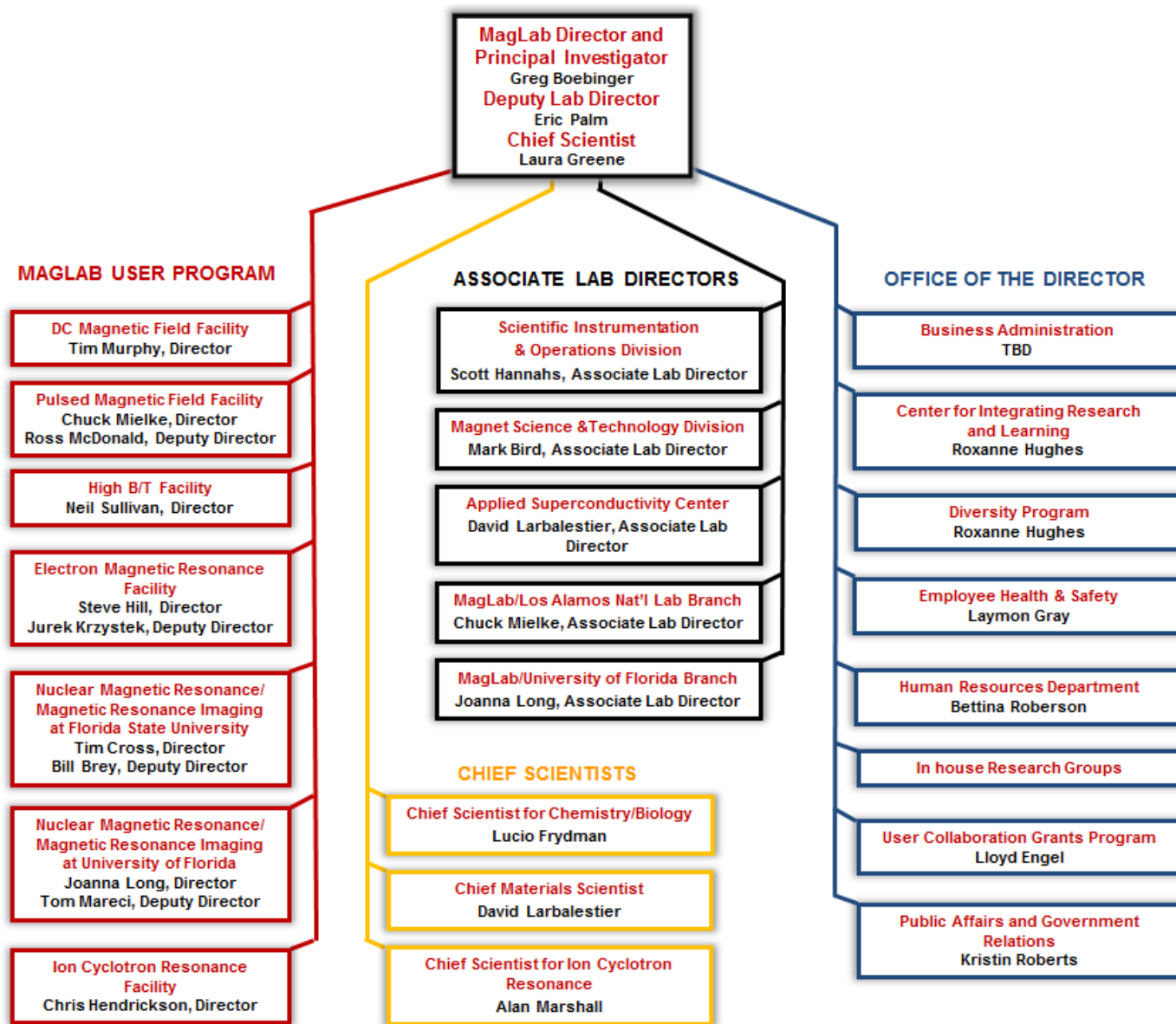

Figure 3: MagLab Organizational Chart (as of June 20, 2017).

# Chapter 2 – Laboratory Management

## 2.2. External Advisory Committee

### Members & Affiliations

#### **Meigan Aronson**

*External Advisory Committee Chair*

Texas A&M University

#### **Madalina Furis**

*Users Committee Chair (ex officio member of EAC)*

University of Vermont

#### **Lora Hine**

Director of Educational Programs for the Cornell High Energy Synchrotron Source

### *Magnet Technology and Materials Subcommittee*

#### **Luca Bottura**

Magnets, Superconductors, and  
Cryostats

#### **Jeff Parrell**

Oxford Superconducting Technology

#### **Bruce P. Strauss**

US Department of Energy

#### **Alan Tennant**

Oak Ridge National Laboratory

### *Biology and Chemistry Subcommittee*

#### **Christoph Boehme**

University of Utah

#### **R. David Britt**

UC-Davis

#### **Jack Freed**

Cornell University

#### **Jean Futrell**

Battelle

#### **Gillian R. Goward**

McMaster University

#### **Robert Griffin**

MIT

#### **Songi Han**

University of California, Santa Barbara

#### **Carol Nilsson**

Lund University

#### **Stanley Opella**

UC- San Diego

#### **Ravinder Reddy**

University of Pennsylvania

#### **Dean Sherry**

UT Southwestern

### *Condensed Matter Subcommittee*

#### **Stuart Brown**

University of California, Los Angeles

#### **Moses Chan**

Penn State University

#### **Barbara A. Jones**

IBM Almaden Research Center

#### **Stephen Julian**

University of Toronto

#### **Philip Kim**

Columbia University

#### **Junichiro Kono**

Rice University

#### **Peter Littlewood**

Argonne National Laboratory

#### **Art Ramirez**

University of California, Santa Cruz

#### **Susan Seestrom**

Los Alamos National Laboratory

#### **Mansour Shayegan**

Princeton University

#### **Nai-Chang Yeh**

California Institute of Technology

# Chapter 2 – Laboratory Management

## 2.3. Users Committee

*The MagLab's Users Committee represents the MagLab's broad, multidisciplinary user community and advises the Lab's leadership on all issues affecting users of our facilities. The Users Committee is elected from the user base of the NHMFL. Each facility has a subcommittee elected by its users to represent their interests to the NHMFL. DC Field and High B/T facilities have a single, combined subcommittee representing the two user facilities. Likewise, the NMR facilities at UF and FSU have a single, combined subcommittee. Pulsed Field, ICR, and EMR facilities have their individual subcommittees. Each subcommittee then elects members to represent it on the Users Executive Committee. This Users Executive Committee elects a chair and two vice chairs. The DC Field/High B/T Advisory Committee, the Pulsed Field Advisory Subcommittee, the EMR Advisory Subcommittee, the NMR/MRI Advisory Committee, and the representative from the ICR Advisory Committee met October 19-21 in Gainesville, FL to discuss the state of the Laboratory and provide feedback to the NSF and MagLab management. The full, unedited 2017 User Advisory Committee Report can be found in Chapter 3.*

### Members & Affiliations

#### *DC Field/ High B/T Advisory Committee*

**Madalina Furis\***, University of Vermont  
**Elizabeth Green**, Dresden High Magnetic Field Laboratory  
**Malte Grosche**, Cambridge University  
**Sara Haravifard\***, Duke University  
**Zhigang Jiang**, Georgia Institute of Technology  
**Lu Li**, University of Michigan  
**Philip Moll**, Max Planck Institute  
**James Williams**, University of Maryland  
**Haidong Zhou**, University of Tennessee

#### *ICR Advisory Committee*

**Jonathan Amster\***, University of Georgia  
**Michael Easterling**, Ohio University  
**Michael Freitas**, Ohio University Medical Center  
**Elizabeth Kujawinski**, Woods Hole Oceanographic Institution  
**Ljiljana Pasa-Tolic**, Pacific Northwest National Laboratory  
**Forest White**, Massachusetts Institute of Technology

#### *Pulsed Field Advisory Committee*

**Charles Agosta**, Clark University  
**Kristen Alberi**, National Renewable Energy Lab  
**Nicolas Butch**, NIST Center for Neutron Research  
**Pei-Chun Ho**, CSU-Fresno  
**Jamie Manson\***, Eastern Washington University  
**Filip Ronning**, Los Alamos National Laboratory

*\*Members of User Executive Committee*

#### *EMR Advisory Committee*

**Erik Cizmar**, P.J. Sararik University  
**Chris Key**, University College London  
**Lloyd Lumata**, University of Texas  
**Dane McCamey\***, The University of New South Wales  
**Hannah Shafaat**, Ohio State University  
**Stefan Stoll**, Department of Chemistry

#### *NMR/MRIs Advisory Committee*

**David Bruce**, University of Ottawa  
**Ed Chekmenev\***, Vanderbilt University  
**Paul Ellis**, Doty Scientific, Inc.  
**Oc Hee Han**, Korea Basic Science Institute  
**Brian Hansen**, University of Aarhus  
**Doug Kojetin**, Scripps Institute  
**Richard Magin**, University of Illinois  
**Len Mueller\***, University of California, Riverside  
**Aaron Rossini**, Iowa State University

# Chapter 2 – Laboratory Management

## 2.4. Personnel

### 2.4.1. Key Faculty and Staff

As of January 3, 2018, seven hundred fifteen people (715) worked for or were affiliated with the MagLab at FSU, UF, and LANL in 2017 compared to 738 in 2016. A list of MagLab key faculty and staff is presented below. All information in the Personnel section is as of January 3, 2018.

#### Principle Investigators

**Greg Boebinger**

Director/Professor,  
Professor of Physics

**Joanna Long**

MagLab Chemistry &  
Biology Director and  
Associate Professor,  
Biochemistry &  
Molecular Biology  
(UF)

**Alan Marshall**

Ion Cyclotron  
Resonance (FSU)

**Charles Mielke**

Director, Pulsed  
Field Facility at LANL  
and  
Deputy Group  
Leader

**Neil Sullivan**

High B/T Facility (UF)

#### User Facility Directors

**Timothy Cross**

Nuclear Magnetic Resonance (FSU)

**Chris Hendrickson**

Ion Cyclotron Resonance

**Stephen Hill**

Electron Magnetic Resonance

**Joanna Long**

Nuclear Magnetic Resonance (UF)

**Charles Mielke**

Pulsed Field

**Tim Murphy**

DC Field

**Neil Sullivan**

High B/T

#### Key Personnel

Name	Position Title
<b>Director's Office</b>	
Boebinger, Gregory	Director/Professor, Professor of Physics
Gray, Laymon	Asst Dir Safety & Security
Hughes, Roxanne	Research Faculty II, Director, Center for Integrating Research and Learning
Jacobson, Thomas	Director, EH&S FSU
Palm, Eric	Deputy Lab Director
Roberson, Bettina	Assistant Director, Administrative Services, Human Resources
Roberts, Kristin	Director of Public Affairs
<b>Management and Administration</b>	
Clark, Eric	Assistant Director, Technology Services
Coyne, Sean	Facilities Engineer
Greene, Laura	Chief Scientist
Hunter, Tra	Plant Engineer
Jensen, Peter	Information Technology Group Manager
Kynoch, John	Assistant Director
McEachern, Judy	Assistant Director, Business Systems
Rea, Clyde	Assistant Director, Business & Financial / Auxiliary Services
Wood, Marshall	Facilities Electrical Supervisor

# Chapter 2 – Laboratory Management

Name	Position Title
<b>DC Instrumentation</b>	
Dalton, Bryon	Scientific Research Specialist
Hannahs, Scott	Research Faculty III
Powell, James	Research Engineer
Vanderlaan, Mark	Research Engineer, Cryogenic Operations
Williams, Vaughan	Research Engineer
<b>Magnet Science &amp; Technology</b>	
Adkins, Todd	Research Engineer
Bird, Mark	Research Faculty III, Director, Magnet Science & Technology
Bole, Scott	Research Engineer
Cantrell, Kurtis	Research Engineer
Dixon, Iain	Research Faculty III
Gavrilin, Andrey	Research Faculty III
Goddard, Robert	Scientific Research Specialist
Gundlach, Scott	Research Engineer
Guo, Wei	Professor
Han, Ke	Research Faculty III
Lu, Jun	Research Faculty II
Marks, Emsley	Research Engineer
Marshall, William	Sr Research Associate
Miller, George	Research Engineer
Noyes, Patrick	Sr Research Associate
O'Reilly, James	Research Engineer
Painter, Thomas	Sr Research Associate
Toth, Jack	Research Faculty III
Van Sciver, Steven	Professor
Viouchkov, Yuri	Research Engineer
Voran, Adam	Research Engineer
Walsh, Robert	Sr Research Associate
Weijers, Hubertus	Research Faculty III
Xin, Yan	Research Faculty III
Zavion, Sheryl	Sr Research Associate (MS&T Operations Manager)
<b>Condensed Matter Science</b>	
Albrecht-Schmitt, Thomas	Professor
Baek, Hongwoo	Research Faculty I
Balicas, Luis	Research Faculty III
Baumbach, Ryan	Research Faculty I
Beekman, Christianne	Assistant Professor
Bonesteel, Nicholas	Professor
Cao, Jianming	Professor
Chiorescu, Irinel	Professor
Choi, Eun Sang	Research Faculty III
Coniglio, William	Research Faculty I
Dalal, Naresh	Professor

# Chapter 2 – Laboratory Management

Name	Position Title
Dobrosavljevic, Vladimir	Professor
Engel, Lloyd	Research Faculty III
Fajer, Piotr	Professor
Gao, Hanwei	Assistant Professor
Graf, David	Research Faculty II
Hill, Stephen	Professor/EMR Director
Jaroszynski, Jan	Research Faculty II
Kovalev, Alexey	Assistant In Research
Krzystek, Jerzy	Research Faculty III
Manousakis, Efstratios	Professor
McGill, Stephen	Research Faculty II
Murphy, Timothy	Director, DC Field Facility
Oates, William	Assistant Professor
Ozarowski, Andrzej	Research Faculty II
Ozerov, Mykhaylo	Research Faculty I
Park, Ju-Hyun	Research Faculty II
Park, Wan Kyu	Research Faculty II
Popovic, Dragana	Research Faculty III
Ramakrishnan, Subramanian	Associate Professor
Reyes, Arneil	Research Faculty III
Rikvold, Per	Professor
Schlottmann, Pedro	Professor
Shatruk, Mykhailo	Assistant Professor
Shehter, Arkady	Research Faculty I
Siegrist, Theo	Professor
Smirnov, Dmitry	Research Faculty III
Smith, Julia	Research Faculty I
Song, Likai	Research Faculty I
Suslov, Alexey	Research Faculty III
Thirunavukkuarasu, Komalavalli	Assistant Professor at FAMU
Tozer, Stanley	Research Faculty III
Trociewitz, Bianca	Research Engineer
Vafek, Oskar	Associate Professor
van Tol, Johan	Research Faculty III
Whalen, Jeffrey	Research Faculty I
Yang, Kun	Professor
<b>LANL</b>	
Balakirev, Fedor	Staff Member
Betts, Jonathan	Director of Operations
Chan, Mun Keat	Staff Member
Coulter, Yates	Head of Generator Operations
Crooker, Scott	Staff Member
Harrison, Neil	Staff Member
Hinrichs, Mark	Electrical Engineer

# Chapter 2 – Laboratory Management

Name	Position Title
Jaime, Marcelo	Staff Member
Maiorov, Boris	Staff Member
McDonald, Ross	Deputy Director, Pulsed Field Facility
Mielke, Charles	Director, Pulsed Field Facility at LANL and Program Director
Migliori, Albert	Staff Member and LANL Fellow
Nguyen, Doan	Director of Pulsed Field Facility Magnet Science and Technology
Singleton, John	Staff Member and LANL Fellow
Zapf, Vivien	Staff Member
<b>CIMAR</b>	
Alamo, Rufina	Professor
Anderson, Lissa	Research Faculty I
Arora, Rajendra	Professor
Blakney, Gregory	Research Faculty II
Brey, William	Research Faculty III
Corilo, Yuri	Research Faculty I, Director of Informatics Research & Modeling
Cross, Timothy	Professor
Frydman, Lucio	Chief Scientist for Chemistry & Biology
Fu, Riqiang	Research Faculty III
Gan, Zhehong	Research Faculty III
Gor'kov, Peter	Sr Research Associate
Grant, Samuel	Associate Professor
Hallinan, Daniel	Assistant Professor
Hendrickson, Christopher	Research Faculty III/Director of ICR Program
Hu, Yan-Yan	Assistant Professor
Hung, Ivan	Associate in Research
Kim, Jeong-su	Associate Professor
Kitchen, Jason	NMR Engineer
Levenson, Cathy	Professor
Litvak, Ilya	Assistant In Research
Lu, Jie	Associate in Research
Marshall, Alan	Professor, Chief Scientist for Ion Cyclotron Resonance (ICR) and Robert O. Lawton Distinguished Professor of Chemistry
McKenna, Amy	Research Faculty II
Qin, Huajun	Associate in Research
Quinn, John	Research Engineer
Ranner, Steven	Research Engineer
Rodgers, Ryan	Research Faculty III, Research Faculty III
Rosenberg, Jens	Research Faculty I
Schepkin, Victor	Research Faculty II
Smith, Donald	Research Faculty I
Weisbrod, Chad	Research Faculty I
Wi, Sungsool	Research Faculty II
Zhou, Huan-Xiang	Professor

# Chapter 2 – Laboratory Management

Name	Position Title
<b>UF</b>	
Angerhofer, Alexander	Professor, Chemistry
Blackband, Stephen	Professor, Neuroscience
Bowers, Clifford	Professor
Butcher, Rebecca	Assistant Professor
Cheng, Hai Ping	Professor of Physics
Christou, George	Drago Chair and Distinguished Professor
Collins, James	Core Research Facility Manager
Elumalai, Malathy	RF Engineer
Fanucci, Gail	Professor
Febo, Marcelo	Assistant Professor
Fitzsimmons, Jeffrey	Professor, Radiology
Forder, John	Associate Professor of Radiology
Hamlin, James	Assistant Professor
Hebard, Arthur	Distinguished Professor of Physics
Hershfield, Selman	Professor
Ingersent, Kevin	Chair of UF Physics Department & Professor, Chair, UF Physics Dept.
Kumar, Pradeep	Emeritus Professor
Lai, Song	Professor of Radiation Oncology and Neurology, Director, CTSI Human Imaging Core McKnight Brain Institute, Director, CTSI Human Imaging Core McKnight Brain Institute
Lee, Yoonseok	Professor
Long, Joanna	Associate Professor, NHMFL Director of AMRIS, NHMFL Director of AMRIS
Luesch, Hendrik	Professor and Chair, Department of Medicinal Chemistry, Professor
Mareci, Thomas	Professor
Maslov, Dmitrii	Professor
Masuhara, Naoto	Senior Engineer, Microkelvin Laboratory
Meisel, Mark	Professor of Physics
Merritt, Matthew	Associate Professor
Murray, Leslie	Assistant Professor
Stanton, Christopher	Professor
Stewart, Gregory	Professor
Sullivan, Neil	Professor, Director of High B/T Facility, Director of High B/T Facility
Takano, Yasumasa	Professor
Talham, Daniel	Professor
Tanner, David	Distinguished Professor of Physics
Vaillancourt, David	Professor
Vandenborne, Krista	Professor
Vasenkov, Sergey	Associate Professor
Walter, Glenn	Associate Professor
Xia, Jian-Sheng	Scholar / Scientist
Zeng, Huadong	Specialist, Animal MRI/S Applications



# Chapter 2 – Laboratory Management

Name	Position Title
<b>ASC</b>	
Abraimov, Dmytro	Research Faculty II
Bosque, Ernesto	Research Faculty I
Cheggour, Najib	Research Faculty II
Cooley, Lance	Professor
Griffin, Van	Senior Research Associate
Hahn, Seungyong	Professor
Hellstrom, Eric	Professor
Jiang, Jianyi	Research Faculty II
Kametani, Fumitake	Assistant Professor
Kim, Youngjae	Research Faculty I
Larbalestier, David	Chief Materials Scientist, Director, Applied Superconductivity Center
Lee, Peter	Research Faculty III
Pamidi, Sastry	Associate Professor, Electrical & Computing Engineering; Associate Director, Center for Advanced Power Systems
Polyanskii, Anatolii	Magneto Optical Research Specialist
Starch, William	Senior Research Associate
Tarantini, Chiara	Research Faculty II
Trociewitz, Ulf	Research Faculty III

# Chapter 2 – Laboratory Management

## 2.4.2. Staffing and Demographics

The MagLab comprises 715 people at its three sites, who are paid by NSF use grant, State of Florida funding, individual investigator awards, as well as home institutions and other sources. Of that number, senior personnel represent the largest group at 31%, followed by graduate students at 23% and other professionals at 13%. The total distribution by NSF classification appears in **Figure 1**.

### MagLab Staffing

Personnel at FSU, UF, and LANL includes NHMFL employees paid by the NSF Core Grant or State

of Florida funding, plus all affiliated professors, post-doctoral researchers and graduate students.

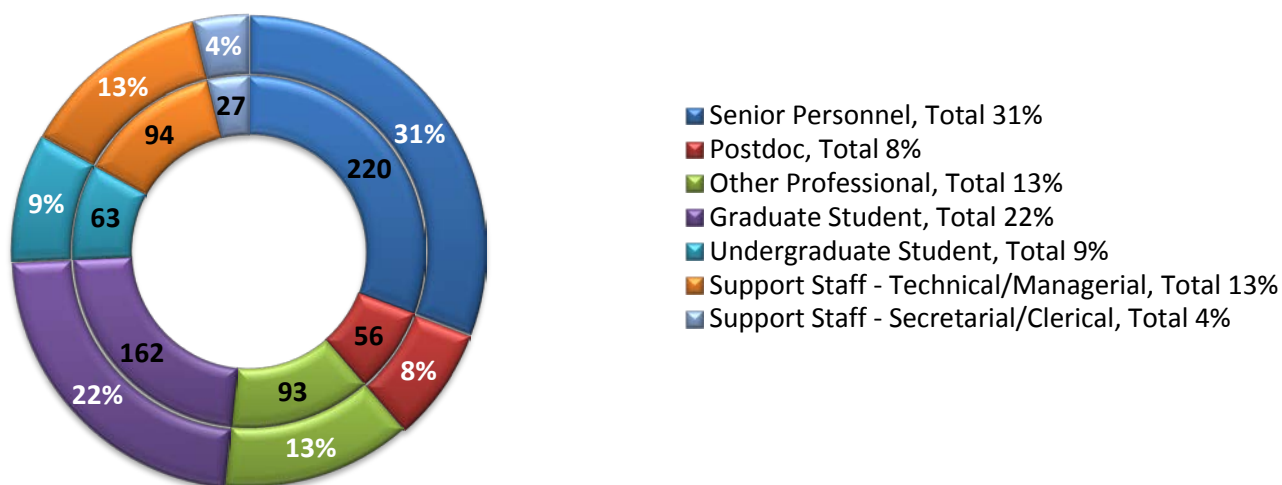

**Figure 1:** MagLab Staffing - Distribution by NSF Classification as of January 3, 2018, Total Personnel: 715

The NHMFL is committed to expanding and maintaining a diverse and inclusive organization to ensure a broad pool of highly qualified applicants for open positions to enhance our diversity efforts. Search committees are strongly encouraged to recruit minorities from underrepresented groups. Positions are advertised in venues that target women and minorities, e.g., Association for Women in Science (AWIS), National Society of Black Physicists (NSBP), etc. Additional contact is made through special subgroups of professional organizations, focused conferences, and workshops. The Director's letter to each search committee chair for senior personnel provides guidelines for best practices to increase the recruitment of members of underrepresented groups. In addition, chairs of search committees for scientific staff meet with the Diversity Committee both before and after the search. This allows the Diversity Committee to help the search committee conduct a search that is as diverse as

possible and then collects lessons learned from each committee to pass on to future search committees.

New permanent hires in 2017: Four scientific senior personnel were hired (1 Black male, 1 White male, 1 Asian male, 1 Hispanic male). One of the four senior personnel was hired as visiting faculty, one was named in a grant, one a rehire and another was changed from postdoc to permanent faculty. The MagLab permanent faculty are hired after an extensive recruitment. Twelve postdoctoral research associates were hired (4 White males, 1 White female, 5 Asian males, and 2 Asian females). Additionally, we hired three STEM related employees (2 White males, 1 Hispanic male).

Overall distribution of diversity for all three sites of the MagLab includes: 44.9% White males, 23.4% Asian males and females, 16.6% White females, 6.1% Black or African American, 6.2% Hispanic and <1% American Indian. The total distribution by diversity appears in **Figure 2**.

# Chapter 2 – Laboratory Management

## MagLab Demographics

Personnel at FSU, UF, and LANL includes NHMFL employees paid by the NSF Core Grant or State

of Florida funding, plus all affiliated professors, post-doctoral researchers and graduate students.

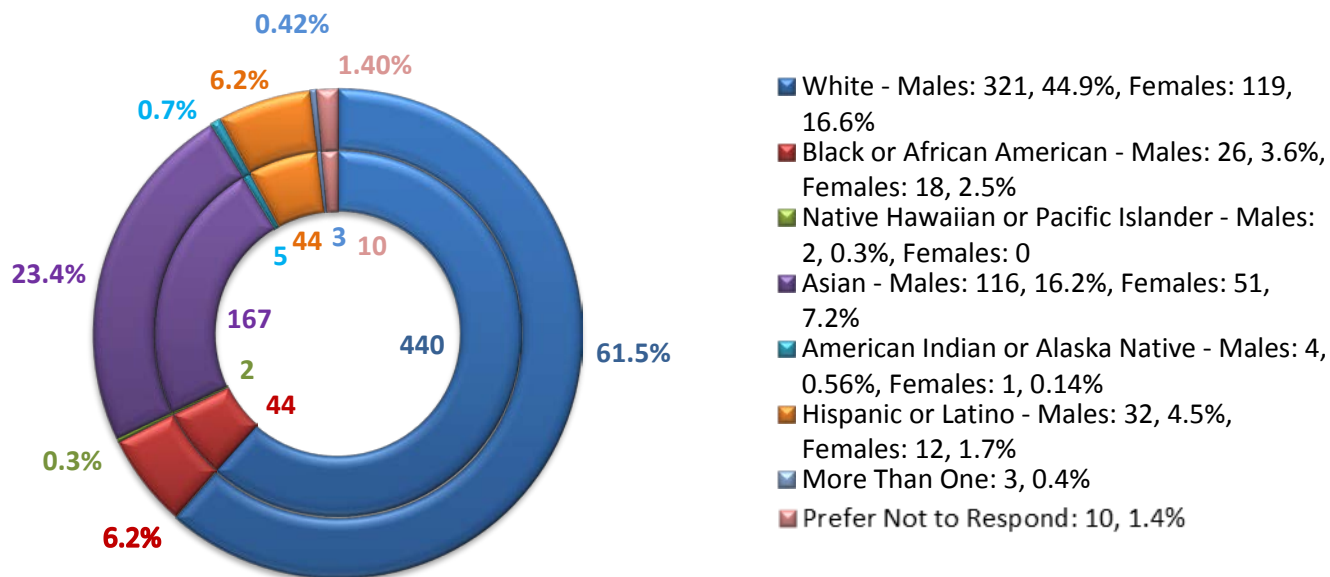

Figure 2: MagLab Demographics - Distribution by Diversity as of January 3, 2018, Total Personnel: 715

# Chapter 2 – Laboratory Management

## 2.5. Diversity and Inclusion

The National High Magnetic Field Laboratory (MagLab) is committed to diversity and inclusion in the STEM workforce at the MagLab and throughout the Nation. To accomplish this goal, our efforts are focused on: **outreach** to underrepresented and underserved populations in STEM from K-early career scientists; utilizing best practices in our **recruitment and hiring** strategies to improve the representation of underrepresented minority groups (including women) at the Lab and in the STEM workforce; and creating a climate where all personnel feel that they have equal opportunities to career development and **mentoring** leading them to want to remain at the Lab/within the STEM workforce (**retention**). As part of this strategic plan, the diversity committee structures its budget and subcommittees to align with these efforts.

The MagLab Diversity Committee meets every other month to discuss and review reports and issues facing the Lab. The members of the NHMFL Diversity Committee in 2017 were (**new members are in bold**):

- Chair: Roxanne Hughes, FSU
- Shelby Anderson, FSU
- Ryan Baumbach, FSU
- Gregory Boebinger, NHMFL Director
- Marcelo Febo, UF
- David Graf, FSU
- Laura Greene, NHMFL Chief Scientist
- Audrey Grockowiak, FSU Postdoc
- Eric Hellstrom, FSU
- **You Lai, FSU Graduate Student**
- Jason Kitchen, FSU
- Amy McKenna, FSU
- Doan Ngyuen, LANL
- Dragana Popovic, FSU
- Bettina Roberson, FSU
- Kari Roberts, FSU
- Kristin Roberts, FSU
- Andreas Stier, LANL Postdoc
- Yasu Takano, UF
- Anke Toth, FSU
- Elizabeth Webb, UF
- Laurel Winter, LANL Postdoc
- Yan Xin, FSU

All of these members work diligently to reach our diversity mission in one and/or all three of the main areas of focus: outreach, recruitment, and retention.

### Outreach

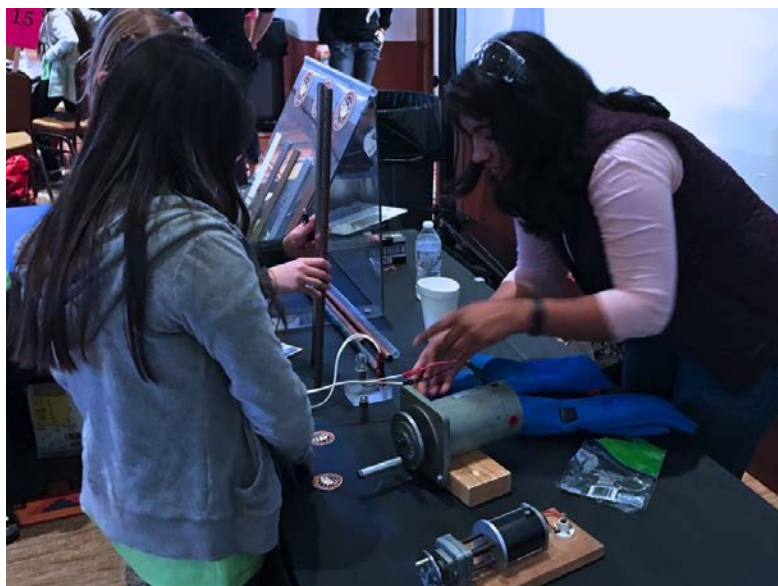

**Left:** Dr. Shaline Chikara representing LANL during the 2017 Expanding Your Horizons New Mexico Technical Career Workshop.

**Bottom:** UF Society of Physics Postdoc Speaking at the 2017 Talk Science with Her Event



# Chapter 2 – Laboratory Management

Diversity and inclusion Outreach highlights from 2017 include:

1. *The Expanding Your Horizons New Mexico Technical Career Workshop* held in Santa Fe, NM in March 2017. This workshop targets middle school girls. The MagLab sponsored this event again in 2017 and scientists from the Pulsed Field Facility at LANL participated. The 2017 NNM-EYH workshop had 247 participants from cities and pueblos all over northern New Mexico, with 52% of the participants coming from Los Alamos. The majority of the participants (74%) were from an underrepresented minority group. Eighty percent of those polled said that their attitudes toward STEM fields and towards STEM professionals were positively affected by their experience at the conference. Eighty percent of the respondents felt more motivated to take STEM classes after their participation in the conference. The workshop is also a great opportunity for female scientists/engineers at the MagLab to serve as role models.
2. UF MagLab and MagLab-affiliated professors celebrated the *2017 United Nations' International Women and Girls in Science Day*, by organizing an event called *Talk Science with Her* to bring eight women scientists together with the Gainesville community for an open discussion. The scientists, who were both professors and postdoctoral researchers, represented a wide variety of fields including physics, engineering, astronomy, biochemistry, and biology, and included two MagLab faculty: Joanna Long, Director of the MagLab's AMRIS user facility and Laura Greene, MagLab Chief Scientist. One hundred people attended to meet the scientists, ask questions, and discover the variety of research that scientists are pursuing.
3. In 2017, the MagLab Tallahassee location was named an award winning *Family Friendly Workplace* by the City of Tallahassee. This was the first year, Tallahassee created the award. Each year the city sends a survey to businesses asking them questions related to work-life balance, family-medical leave, and workplace policies to determine which businesses have reached the level of award winning.

More information on the MagLab's outreach can be found in **Chapter 4**.

## Recruitment and Hiring

The Diversity Committee has two subcommittees that are responsible for overseeing recruitment and hiring procedures. The first of these is the Compliance Subcommittee, chaired by Jason Kitchen. Members of this subcommittee ensure that hiring committees for STEM positions follow the proper procedures outlined in the hiring committee checklist. Members review each hiring committees' initial advertisement for new positions to ensure that the advertisements are sent to networks that reach underrepresented groups and that the descriptions follow the best practices outlined by current research. Before hiring committees make a final offer to a candidate, they meet (in person or via email) with the compliance subcommittee for a review of the process. In 2017, there were four MagLab faculty position searches, one of which was initiated in the fall of 2016. Two of the four searches were finalized with acceptance of offers, and two remain outstanding into 2018. One of the new hires was a member of an underrepresented group in STEM. The other finalized search resulted in the re-hire of a person who was not a member of an underrepresented STEM population.

The Recruitment Subcommittee, chaired by Kristin Roberts, reviews the Lab's current recruiting practices and provides suggestions for improvement. Part of the Diversity Budget is allocated for recruitment (e.g. travel to conferences or Minority Serving Institutions.) In 2017, one recruitment trip was funded by the Diversity Committee. Dr. Peter Morton visited the Virginia Institute of Marine Sciences in September 2017 where he gave a guest seminar lecture and built new collaborations. He also learned from the director, Debbie Bronk, who is a leader in marine nutrient cycles and has spearheaded mentoring programs designed for early career and minority scientists. Throughout the year, the Recruitment Subcommittee continued to play a stronger role in promoting specific MagLab positions on the Lab's social media sites. All positions were posted to the MagLab website and shared across Facebook, Twitter, and LinkedIn multiple times while they were active, garnering thousands of additional views and engagements from potential candidates.

# Chapter 2 – Laboratory Management

## Retention, Advancement, and Mentoring

In an effort to improve Recruitment, Retention, Advancement, and Mentoring for women faculty, Roxanne Hughes worked with a team of faculty (Tamara Bertrand Jones – FSU Education, Charmane Caldwell – FSU/FAMU College of Engineering, Michelle Douglas – FSU HR, and Ashby Plant - FSU Psychology) in 2017 to develop an NSF ADVANCE grant which was submitted in November. This ADVANCE Adaptation Proposal proposed the creation of four programs at Florida State University (FSU) to improve the recruitment, retention, and mentoring of women faculty in STEM departments through: (1) FSU Enhance: a recruitment best practices workshop for STEM departments modeled after Montana State University’s ADVANCE hiring committee training program; (2) STEM Women Faculty: an Affinity Group for STEM women faculty that begins with a networking event in August 2018; (3) FSU ADVANCE Scholars: a formal mentoring program for both tenure track and research faculty at the assistant and associate levels modeled after Florida International University’s ADVANCE Faculty Mentor Program; (4) FSU ADVANCE Community Conversations: a community conversation series that addresses current issues affecting FSU STEM women faculty. This series will focus on mentoring best practices, strategies for improving climate and recruitment, along with conversations on hiring and recruitment. These proposed adaptations were determined based on faculty input from a 2014 COACHE faculty satisfaction survey and a May 2017 internal survey of STEM faculty at FSU. The ADVANCE Adaptation proposal will correspond with new programs and policies linked to FSU’s updated 2017-2022 Strategic Plan.

The MagLab conducted its third internal Climate Survey in 2017. As a result of this survey, in 2018, we will work with postdocs supervisors and postdocs to ensure that meaningful annual reviews occur that provide feedback to the postdocs. In addition, on the survey staff members across various categories indicated that they would like to have more input on and would like to see their ideas incorporated into MagLab policy. In 2018, we will encourage department heads to make policies transparent. We will also encourage managers to visit individuals - who might not speak up in meetings - after meetings to ensure all

feedback has been heard and valued. Finally, we will be working to make sure that MagLab employees across the board exhibit professional behavior to all of their colleagues especially women.

We have an anonymous reporting system for MagLab employees to report issues that they see or experience. In 2017, we had 13 reports, which allowed MagLab leadership to address areas of concerns.

In March of 2017, Laura Greene, Dragana Popovic, and Amy McKenna led a regular networking session for women faculty at the MagLab. Open ended comments on the 2017 Climate Survey indicated that this group made participants feel more supported. In 2018, we are encouraging MagLab employees to start other affinity groups that could address isolation issues.

In an effort to improve diversity and inclusion at the Lab, the Diversity Committee increased the number of sessions it held in 2017. In addition to the annual Strategies for Recruitment and Retention of Faculty (previously known as the Faculty Recruitment for Excellence and Diversity), training held in April, the Diversity committee also scheduled and facilitated the following:

1. In February, representatives from FSU’s Center for Leadership and Social Change came to the Lab for the second year in a row to conduct a presentation on *Cross Cultural Mentoring*.
2. Based on a request from the 2016 Climate Survey, we held three intercultural dialogue sessions for international and domestic staff, students, and faculty during the 2017 spring semester. This was facilitated by the FSU Center for Global Engagement.
3. In May, two representatives from FSU’s Center for Leadership and Social Change came to the Lab to conduct a presentation on *Microaggressions*.
4. In May, the FSU facility held a mandatory *Sexual Misconduct* workshop for supervisors and employees to review Title IX reporting procedures. This presentation was conducted by the FSU HR Sexual Misconduct Reporting representative.
5. In December, Laura Greene facilitated a *COACH* workshop on negotiation skills.

We plan to hold some of these sessions again in 2018. The Climate Survey also asks for recommendations for sessions. We hope to bring experts to the

# Chapter 2 – Laboratory Management

MagLab in 2018 to conduct a *Bystander Intervention* training and a *Breaking the Prejudice Habit* training.

In addition to this work, the Diversity Retention, Advancement, and Mentoring Subcommittee reviews and votes on all budget requests for retention/advancement, which include professional development travel grants and bridge funding. In 2017, twelve MagLab scientists applied for and received funding through the Professional Development Travel Grant. Of these, one was research faculty, seven were postdocs, and four were graduate students. Four scientists used the funds to travel to workshops on techniques related to their research, five went to annual meetings of their national association, one went to present on research conducted at the MagLab, and two went to Labs at other institutions to collaborate on projects that were started at the MagLab.

Bridge funding supports students and postdocs at the MagLab who are between funding sources and would otherwise not be paid during the transition time. This allows the MagLab to retain students and postdocs who have already been trained in MagLab research techniques and procedures across multiple grant cycles rather than for only a single project. 2017 Bridge funding supported five undergraduate students (one in DC Field, one in CMS, one in ASC, and two in Geochemistry), three graduate students (one in MS&T, one in CMS, and one in ASC), and one postdoc in Geochemistry.

The MagLab also offers a *Dependent Care Travel Grant* program, which provides up to \$800 for travel expenses for MagLab scientists traveling to conferences or MagLab users traveling to any of the three MagLab facilities. This money can be used to pay for dependent care costs. In 2017, four individuals utilized this funding opportunity: two MagLab postdocs, one MagLab research faculty member, and one MagLab user.

## Diversity and Inclusion Professional Development and Advice

In addition to the internal Climate Survey and other metrics (anonymous reporting through *diversemag*, confidential consultations with Roxanne Hughes or other members of the Diversity Committee), members of the MagLab Diversity Committee serve on committees that allow them to benefit from others' expertise and share the MagLab's successes. Dragana Popovic and Roxanne Hughes serve on the FSU Diversity and Inclusion Committee. In 2017, they both served on

the Faculty Recruitment and Retention Working Group. As part of this group, they were able to review the final version of FSU's Strategic Plan and discuss goals for diversity initiatives based on this plan. Roxanne continues to be a part of the FSU National Coalition Building Institute (NCBI) Leadership team. NCBI is an international, non-profit, leadership training organization that works to eliminate prejudice and discrimination. She co-led three trainings in 2017 for FSU faculty, staff, and students. Roxanne is a member of the American Physical Society's Committee on the Status of Women in Physics. During 2017, she served on the Sexual Harassment subcommittee wherein the members studied effective practices for stopping sexual harassment at meetings.

The MagLab also utilizes an External Advisory Committee who reviews our policies and procedures. In 2017, this committee reviewed an executive summary of our 2016 Climate Survey Report and our 2016 Annual Report Chapter. The members of our External Advisory Committee in 2017 were:

- *C.J. Bacino*, LANL Diversity Director
- *Susan Blessing*, FSU Physics Professor, Women in Math, Science, and Engineering Living and Learning (WIMSE) Director
- *Alberto Camargo*, Diversity Program Manager, Argonne National Laboratory
- *Charmane Caldwell*, Diversity and Inclusion Coordinator for Florida Agricultural and Mechanical University-Florida State University College of Engineering
- *Simon Capstick*, FSU Physics Professor *Donna Dean*, Tulane University School of Science and Engineering retired, Research focuses on improving mentoring for women
- *Ted Hodapp*, American Physical Society Director of Education and Diversity
- *Keisha John*, Director of Diversity Programs, Graduate and Postdoctoral Affairs, University of Virginia
- *Michelle Douglas*, Florida State University Director of Equal Opportunity and Compliance
- *Nancy Marcus*, FSU Dean of Graduate School
- *Karen Molek*, University of West Florida, Chemistry Associate Professor
- *Bob Parks*, Director of University of Florida Training and Organizational Development

# Chapter 2 – Laboratory Management

In January of 2017, Roxanne Hughes sent a copy of the MagLab Diversity Annual Report Chapter and an Executive Summary of the 2016 Climate Survey to the members of the External Advisory Committee asking them to read the documents and specifically respond to the following: (1) “What advice do you have for how we can improve our recruitment for faculty positions? We currently have hiring committees advertise in journals and venues that serve underrepresented minority groups. The checklist that we give to all hiring committees is attached. Any advice on how we can improve the hiring process would be greatly appreciated.”(2) “I would appreciate any advice on how to better articulate issues and get people on board with the overall concept of respect and the fact that promoting diversity does not mean that majority groups must suffer.”

Overall, the members of the committee were impressed with what the MagLab is currently doing in terms of Recruitment and Retention. For the first point of advice, members suggested that recruitment is most successful when people of color and women see a climate where they are welcomed and valued for their scientific input. They also explained that diversity and inclusion can only be successful when it is demonstrated by the director. It is clear that leadership values the recruitment process. In 2017, Greg Boebinger took time away from preparation for the NSF renewal to conduct a thorough search for a faculty position in his lab group. Committee members suggested sending MagLab faculty to recruit at Minority Serving Conferences and/or sessions at larger conferences. We continue to advertise the Recruitment funding for these efforts. The committee also advocated that faculty should be “on the look out” for potential hires at conferences and invite them to the Lab to speak even if a hire is not imminent. The MagLab Recruitment funding could be used for this. The members were very supportive of our intercultural dialogues that would bring international and domestic employees together, particularly since it was requested on the 2016 Climate Survey.

For the second point of advice, members advocated citing quality studies to demonstrate the

need for effective practices in recruitment and retention and to highlight implicit bias. We continue to hold a *Strategies for Recruitment and Retention* workshop that utilized implicit bias work and current research on both implicit bias and effective practices for recruitment and retention. Anecdotally, Roxanne found that when the #MeToo movement became well-known, many members of the majority demographic began to more readily accept the issue of sexual harassment. Our External Advisory Committee members suggested utilizing male allies at the MagLab to help change the climate for women. They suggested informal office hours or chats with individuals about the diversity initiatives. Roxanne held an office hour in the summer and members of the Diversity Committee have indicated that informal chats have increased in 2017. The members also suggested approaching people by asking for their input rather than giving them answers. One member suggested that it would be good for the External Advisory Committee to meet every other year via WebEx or in person.

## Plans for 2018

In 2018, members of the MagLab Diversity Committee (Roxanne Hughes, Amy McKenna, Kari Roberts, and Elizabeth Webb) plan to attend the University of Michigan *ADVANCE Making STRIDES* Conference to learn current effective practices for the recruitment and retention of women in STEM. Roxanne continues to work closely with FSU’s NCBI team to conduct trainings for FSU faculty, staff, and students. Roxanne and faculty at FSU and FAMU submitted an NSF ADVANCE grant in 2017, we are hoping that this grant is funded so that we can develop workshops for STEM departments (including the MagLab) to improve the recruitment and retention of women (particularly women of color) faculty in STEM departments. This grant will also allow us to start a networking group for women faculty across departments and a matched mentoring program for women faculty. MagLab faculty along with FAMU faculty are submitting a PREM grant in 2018 to improve our recruitment and retention of students, particularly students of color.



# Chapter 2 – Laboratory Management

## 2.6. Safety

A central focus of all activities conducted at the National High Magnetic Field Laboratory (MagLab) is to ensure employees, users, and visitors are provided with a safe and educational environment. The MagLab’s Environmental Health and Safety (EH&S) team works collaboratively with management, researchers, staff, and users, as well as with other public and private entities, to proactively mitigate hazards in our industrial, Laboratory, and office settings.

### Integrated Safety Management

The MagLab uses Integrated Safety Management (ISM) to integrate safety and health requirements and controls into daily work activities to ensure the protection of the public, worker, and environment. An integral part of the ISM is to analyze the hazards of the job to be performed and controls used to mitigate those hazards. To complete the analysis, a Task Hazard Analysis (THA) worksheet is completed before initiating work. The THA worksheet was revised in 2016 and implemented during 2017. The revised THA considers the worker’s familiarity and complexity of the task to be completed. The THA worksheet is used as a tool to document hazards and safety controls associated with a job activity and to assess a residual risk level. The steps for completing the THA are to:

1. List specific tasks associated with the scope of a work activity.
2. Identify the potential hazards for each task.
3. Determine the necessary controls.

4. Assess the residual risk level.
5. Determine the approval requirements and how the work will proceed.
6. Provide feedback for continuous improvement.

The updated THA worksheet provides a rigorous assessment of the work to be performed, potential hazards, and controls utilized to ensure work is performed safely.

### Investments

Our investments in safety equipment and materials along with management support and employee involvement demonstrates our strong commitment to sensibly utilize resources in a manner that protect all MagLab personnel, property, and the environment.

In 2017 the MagLab strategically invested over \$60,000 for safety related equipment, supplies, training, and processes. Some of the key investments included installation of eyewash/drench hoses in new areas, updates to the Safety Clearance User Database used for lockout tagout verification of hazardous energy, and the design and installation of a new resistive magnet cell disconnect voltage verification system.



### Safety Survey 2016

In order to gauge the continued effectiveness of the Safety program and the overall attitude toward safety, the MagLab conducted its Annual Safety Survey. The data from over 250 respondents provided reliable and measurable feedback. The results of the 2017 Safety Survey indicate an improved climate for the Integrated Safety Management (ISM) process and our EH&S program.

The MagLab continues to foster a sustainable and strong safety culture. Some examples of the activities that contribute to a favorable safety climate and commitment to a strong safety culture at the MagLab are listed below.

- Safety is viewed as an investment not a cost.
- Management drives and is actively involved with promoting our Safety Culture.

MAGNETIC FIELD LABORATORY Task Hazard Analysis Worksheet					
Project:		Location:		Start Date:	End Date:
Project Lead:		Dept/Lab:		Authorized Employees:	
Notes:					
(1) TASKS	(2) POTENTIAL HAZARDS	(3) CONTROLS	(4) RESIDUAL RISK	Authorizations	
			HAZARD CONSEQ		
			RESIDUAL		
			HAZARD CONSEQ		
			RESIDUAL		
			HAZARD CONSEQ		
			RESIDUAL		
			HAZARD CONSEQ		
			RESIDUAL		
			HAZARD CONSEQ		
			RESIDUAL		
			HAZARD CONSEQ		
			RESIDUAL		

Hazard Assessment Matrix		Complexity			
		Simple	Modicate	Diffcult	
Familiarity Level	Very Familiar	1	2	3	
	Somewhat Familiar	2	3	4	
	Unfamiliar	3	4	5	

Assessed Hazard	Consequences				
	Highly	Minor	Severe	Slight	Severe
5	Low Med	Medium	Med High		
4	Low	Low Med	Medium	Med High	
3	Low	Low Med	Medium	Med High	High
2	Low	Low Med	Medium	Medium	High
1	Low	Low	Low Med	Low Med	Medium

Task Hazard Analysis Worksheet

# Chapter 2 – Laboratory Management

- Quarterly Safety Meetings are conducted by the Director of the MagLab to address Lab-wide safety issues and initiatives.
- The Director of the MagLab and Director of Safety routinely walk through the Lab areas to engage researchers, staff, and users, and to observe ongoing work.
- New Employee Orientation is provided to all incoming employees with specific emphasis on our ISM System. New employees are taught that safety is the top priority at the MagLab, to have a questioning attitude about their safety, our Stop Work Policy, and no fault self-reporting near miss and accident policy.

National Institutes of Health. This support included review of research proposals related to biohazardous materials, biohazardous-waste disposal, and biosafety training.

The Biological Safety Office conducted equipment inspections and vertebrate animal medical monitoring for researchers and users. Safety equipment inspections included annual inspections of fume hoods, eyewashes, safety showers, and biosafety cabinets, as well as any additional inspections requested by researchers and users, or following maintenance or repairs of Laboratory equipment. The Biological Safety Office also provided guidance on new equipment installation and renovation projects.

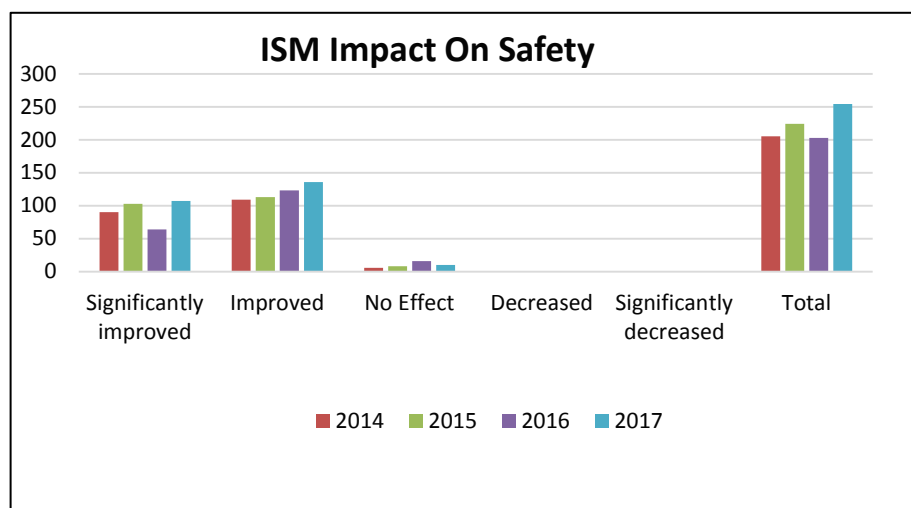

## Laboratory Safety

The Laboratory Safety Office completed biannual inspections of all Laboratory spaces at the MagLab. Inspection findings were provided to each Laboratory including positive feedback for safe practices observed. The Laboratory Safety Office provided real-time guidance to researchers during the inspections concerning needed corrective actions.

The Laboratory Safety Office also provided guidance to researchers and users who require the use of controlled substances in their research and consultations concerning occupational risk exposure in the Laboratory. The Laboratory Safety Office reviewed and updated Laboratory postings.

## Safety Support and Coordination from Main Campus Safety Team

### Chemical Safety

The Chemical Safety Office provided chemical and hazardous waste pick-ups and hazardous waste management support. Waste pick-ups were scheduled by phone or through an online system. Additionally, hazardous waste was stored at the Southwest Campus 180-day storage facility until shipped. The Chemical Safety Office also provided chemical safety support to the MagLab.

### Biological Safety

The Biological Safety Office worked with researchers and users to ensure work with Biosafety Level 2 (BSL-2) materials was completed in accordance with the regulation and safety guidelines set forth by the Centers for Disease Control and Prevention and the

### Radiation Safety

The Radiation Safety Office provided oversight of the MagLab Laser Safety Program. This oversight included the registration and inspection of laser producing devices, assisting with new equipment setup, participation on the Laser Safety Committee, management of inventory, and procedure audits.

The Radiation Safety Office served as subject matter experts for any experiment or procedure involving radiation, x-rays, or laser beams. This includes regulatory support related to the use of radioisotopes including radioactive materials permitting, monthly use area surveys, maintenance and calibration of radiation detection equipment, personnel dosimetry, and support of research involving the use of radioactive materials.

# Chapter 2 – Laboratory Management

## Committees

### *Safety Committee*

The MagLab Safety Committee met monthly to discuss updates to safety programs and procedures, safety concerns, and actions taken or proposed to mitigate hazards associated with those concerns and planning. New MagLab Committee members were added from Los Alamos National Laboratory and the University of Florida. The addition of these Facility representatives to the Safety Committee allows for better coordination and collaboration of safety concerns and lessons learned. Both locations were also added to the MagLab's Safety Concerns reporting portal.

### *Lock/Tag Verification Committee*

The Committee reviews and updates the MagLab's Lock/Tag/Verification (LTV) Program as needed and addresses concerns and issues related to the LTV Program throughout the year. The Committee worked to update the Safety Clearance User Database (SCUD). Changes to the SCUD will be implemented in 2018.

### *Cryogen Safety Committee*

The Committee reviewed and updated the Cryogen Safety Program. Some of the updates to the Program included oxygen deficient atmosphere assessments in locations that cryogenics are used, inspections of ODH sensor systems, and Dewar pressure relief inspections.

### *Laser Safety Committee*

The Committee met to review laser safety at the MagLab. Committee members formed a subcommittee to review laser safety procedures and training requirements for laser users.

## Safety Highlights

### *Safety Team Visits UF Facilities*

The Director and Associate Director of FSU's EH&S team visited the High B/T and AMRIS Facilities. During the meeting, the Director of UF EH&S participated in a walkthrough of both facilities. The goal of the visit was to foster more coordination and collaboration between the FSU and UF MagLab Facilities and Safety Team. After this visit, two members of the UF EH&S team visited the FSU MagLab Facility in Tallahassee. During the visit they received a tour of the

Lab and training on how the MagLab conducts oxygen deficient hazard analysis. They also learned about the MagLab's Integrated Management System and how the MagLab fosters an effective Safety Culture.

### *Series Connected Hybrid Safety Review*

During 2017 the 36 Tesla Series Connected Hybrid Magnet became available to users. The MagLab Safety Team worked with the magnet designers and operators of the SCH to complete a safety review. The purpose of the review was to identify and address safety concerns associated with operation of the SCH during normal user operations. The review included safety aspects related to the SCH housing and cooling water system, high voltage power systems, cryogen systems, magnetic fields, user access areas, emergency response, magnet quench response, and impacts to adjacent cells. Based on the safety review appropriate mitigation was implemented to address safety hazards and user training was developed. Prior to receiving access to the SCH, users must complete an online and hands on training specific to SCH operations.

### *Emergency Action Preparedness for Hurricane Irma*

Hurricane Irma (a Category 4 hurricane) made landfall in South Florida on September 10<sup>th</sup>, 2017 and traveled North causing major impacts to Florida. On September 11<sup>th</sup> the storm passed over the panhandle area of Florida. The MagLab activated its Natural Disaster Preparedness Emergency Action Plan (EAP) six days prior to Irma impacting Tallahassee. The MagLab's EAP Team met daily to discuss weather updates, preparedness, and to coordinate with FSU leadership. Departments were directed to review their specific preparedness and recovery plans for shut down and initiate actions to secure areas and equipment as Irma approached. Critical areas of concern such as cryogen supplies, fuel for backup generators, computer support, communications, and overall security and safety at the MagLab were addressed.

Using lessons learned from Hurricane Hermine which impacted the MagLab one-year prior, the Team utilized a mobile phone application that facilitated effective and efficient communication before, during and after Irma, and implemented emergency load shedding for backup power supplies in preparation for short and long term power interruptions. Current and scheduled users were notified of travel disruption issues and were provided information concerning sheltering in

# Chapter 2 – Laboratory Management

place, rescheduling of magnet time, evacuation plans, and local emergency services.

After Irma passed, two MagLab recovery teams assessed facilities for damage and safety hazards. The teams were able to return the MagLab to a safe operational status that allowed activities to resume the day after Irma passed. Normal operations resumed on September 18, 2017.

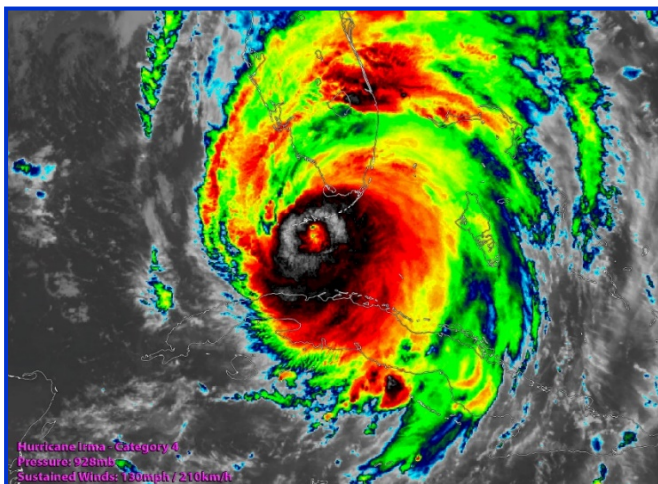

Hurricane Irma makes landfall in South Florida.



Members of the EAP Team meet for a debrief after Hurricane Irma.

## Annual Maintenance Shutdown

During November and December, the MagLab performed its annual maintenance shutdown. Prior to shut down a number of planning meetings were held to discuss work plans, safety equipment needs, organization of lockout/tagout boards, and contractor coordination. To facilitate daily work tasks detailed lockout/tagout boards were used to better organize and coordinate lockouts.

Prior to initiating work each morning, all workgroups, including contractors, met together to review and discuss each workgroup's planned work for the day. This facilitated communication amongst workgroups prior to initiating tasks to ensure jobs were safely coordinated and all safety hazards were communicated. Also discussed were any difficulties or

lessons learned from the previous workday. At the conclusion of the meeting, safety audits were performed and any extensive or widely affected lockouts were established, this allowed the primary worker to instruct and organize authorized employees on the lockouts for better awareness for all involved.

Although there were numerous inter-dependent work processes and workgroups involved with the shutdown, the MagLab's Integrated Safety Management process provided the careful planning and coordination that ensured that all employees and contractors safely completed their assigned work activities without incident.

## Installation of Magnet Cell Disconnect Voltage Verification System

The MagLab electronics division engineered a new method for ensuring that magnet cell disconnects can be verified as being opened or closed with the use of a multi-meter. This new design provides a substantial improvement over the previous method of having a qualified and authorized NFPA-70E trained employee to enter the Buss Tunnel to ensure visually that the disconnects are open. This method greatly reduces the possible exposure of our qualified and authorized employees to the high electrical hazard present in that area.

The new system measures the AC and DC voltage with respect to ground of all the power supply busses and magnet terminals. The system applies an AC voltage from each power supply bus to earth ground. A unique voltage is applied to each pair of power supply busses. This allows each power supply to be identified through a voltage measurement. If voltage can be measured on each power supply bus and no voltage measured on the magnet terminals, all disconnect switches are verified to be open.

To electrically verify the absence of voltage, a three-point voltage measurement must be used. The voltage verification system allows the voltmeters to be tested at a known voltage before and after measurement of busses and magnet terminals. A DC voltage can be applied to the magnet terminals while the cell disconnect switches are open to ensure that the system is measuring these points correctly.

The system can be used while the magnet power supplies are turned on. All power supplies must be on and operating so that each bus will be at a voltage greater than zero. Each magnet in operation during the

# Chapter 2 – Laboratory Management

verification should have a terminal voltage greater than 10 volts to confirm that voltage is present on the busses. If a number of power supplies are on and others are off, this system cannot be used. At present the Disconnect Voltage Verification System has been installed in cells 6 & 15 and is currently undergoing testing. Upon successful completion, the MabLab plans to install the System in other cells during 2018.

## *Cooling Tower Upgrades*

Annual Cooling Tower upgrades and preventative maintenance were completed. Maintenance included removal of bio-growth accumulation, interior wood replacement and replacement of damaged fiberglass components and corroded hardware.

During the work planning stage, a concern regarding the potential exposure to the bacteria Legionella was expressed. The MagLab uses oxidizing agents such as chlorine and bromine to effectively control Legionella in the cooling tower water basin.

However, the wood replacement was going to require demolition increasing the chance for potential exposure. A Task Hazard Analysis was completed and the hazard controls to perform the work were developed and implemented. Hazard controls identified required workers to wear the following personal protective equipment when doing wood demolition, replacement, and repair:

- a) Respirator: Powered air purifying respirators were issued to each employee.
- b) Coverall: Clean coveralls were issued for each 4-hour work shift.
- c) Safety glasses, work gloves, and boots were also issued.

The workers were provided medical screening, were given a respirator fit test, and completed training on respirator use and the hazards of exposure to Legionella. Work was completed safely and without incident.

# Chapter 2 – Laboratory Management

## 2.7. Budget

**Table 1: SUMMARY PROPOSAL BUDGET January – December 2017**  
Florida State University/ National MagLab

PRINCIPAL INVESTIGATOR/PROJECT DIRECTOR Gregory S. Boebinger				
	NSF-Funded			Funds
A. List each separately with name and title. (A.7. Show number in brackets)	Person-months			Requested By
	CAL	ACAD	SUMR	Proposer
(65) TOTAL SENIOR PERSONNEL (1-6)	508.50	0.00	0.00	4,549,705
<b>B. OTHER PERSONNEL (SHOW NUMBERS IN BRACKETS)</b>				
1. (7) POSTDOCTORAL ASSOCIATES	78.00	0.00	0.00	335,245
2. (80) OTHER PROFESSIONALS (TECHNICIAN, PROGRAMMER, ETC.)	638.85	0.00	0.00	3,389,270
3. (4) GRADUATE STUDENTS				75,112
4. (5) UNDERGRADUATE STUDENTS				41,495
5. (15) SECRETARIAL - CLERICAL (IF CHARGED DIRECTLY)				144,966
6. (0) OTHER Temporary				0
TOTAL SALARIES AND WAGES (A + B)				8,535,793
<b>C. FRINGE BENEFITS (IF CHARGED AS DIRECT COSTS)</b>				
TOTAL SALARIES, WAGES AND FRINGE BENEFITS (A + B + C)				11,403,419
<b>D. EQUIPMENT (LIST ITEM AND DOLLAR AMOUNT FOR EACH ITEM EXCEEDING \$5,000.)</b>				
TOTAL EQUIPMENT				931,682
<b>E. TRAVEL</b>		1. DOMESTIC (INCL. CANADA, MEXICO AND U.S. POSSESSIONS)		193,399
		2. FOREIGN		42,467
<b>F. PARTICIPANT SUPPORT</b>				
1. STIPENDS	111,000			
2. TRAVEL	6,000			
3. SUBSISTENCE	23,100			
4. OTHER	2,058			
TOTAL NUMBER OF PARTICIPANTS (25) (15 REU's and 10 RET's)	TOTAL PARTICIPANT COSTS			142,158
<b>G. OTHER DIRECT COSTS</b>				
1. MATERIALS AND SUPPLIES				2,485,713
2. PUBLICATION/DOCUMENTATION/DISSEMINATION				0
3. CONSULTANT SERVICES				0
4. COMPUTER SERVICES				0
5. SUBAWARDS				8,848,069
6. OTHER Electricity and Tuition				1,865,594
TOTAL OTHER DIRECT COSTS				13,199,376
<b>H. TOTAL DIRECT COSTS (A THROUGH G)</b>				
25,912,501				
<b>I. INDIRECT COSTS (F&amp;A) (SPECIFY RATE AND BASE)</b>				
Rate: 70.0% Base \$14,124,998				
TOTAL INDIRECT COSTS (F&A)				
9,887,499				
<b>J. TOTAL DIRECT AND INDIRECT COSTS (H + I)</b>				
35,800,000				

# Chapter 2 – Laboratory Management

**Table 2: SUPPLEMENT FUNDING 2017**

Florida State University/ National MagLab

PRINCIPAL INVESTIGATOR/PROJECT DIRECTOR Gregory S. Boebinger				
A. List each separately with name and title. (A.7. Show number in brackets)	NSF-Funded			Funds
	Person-months			Requested By
	CAL	ACAD	SUMR	Proposer
(61) TOTAL SENIOR PERSONNEL (1-6)	132.40	0.00	0.00	1,214,892
<b>B. OTHER PERSONNEL (SHOW NUMBERS IN BRACKETS)</b>				
1. (4) POSTDOCTORAL ASSOCIATES	12.80	0.00	0.00	55,814
2. (78) OTHER PROFESSIONALS (TECHNICIAN, PROGRAMMER, ETC.)	142.60	0.00	0.00	802,042
3. (3) GRADUATE STUDENTS				20,447
4. (4) UNDERGRADUATE STUDENTS				8,756
5. (13) SECRETARIAL - CLERICAL (IF CHARGED DIRECTLY)				32,126
6. (0) OTHER Temporary				0
TOTAL SALARIES AND WAGES (A + B)				2,134,077
<b>C. FRINGE BENEFITS (IF CHARGED AS DIRECT COSTS)</b>				
TOTAL SALARIES, WAGES AND FRINGE BENEFITS (A + B + C)				737,395
<b>D. EQUIPMENT (LIST ITEM AND DOLLAR AMOUNT FOR EACH ITEM EXCEEDING \$5,000.)</b>				
TOTAL EQUIPMENT				198,050
<b>E. TRAVEL</b>		<b>1. DOMESTIC (INCL. CANADA, MEXICO AND U.S. POSSESSIONS)</b>		44,014
		<b>2. FOREIGN</b>		
<b>F. PARTICIPANT SUPPORT</b>				
1. STIPENDS	0			
2. TRAVEL	0			
3. SUBSISTENCE	0			
4. OTHER	0			
TOTAL NUMBER OF PARTICIPANTS ( )	TOTAL PARTICIPANT COSTS			0
<b>G. OTHER DIRECT COSTS</b>				
1. MATERIALS AND SUPPLIES				439,975
2. PUBLICATION/DOCUMENTATION/DISSEMINATION				0
3. CONSULTANT SERVICES				0
4. COMPUTER SERVICES				0
5. SUBAWARDS				2,401,549
6. OTHER Tuition - \$8,212; Electricity \$625,000				633,212
TOTAL OTHER DIRECT COSTS				3,474,736
<b>H. TOTAL DIRECT COSTS (A THROUGH G)</b>				
6,588,272				
<b>I. INDIRECT COSTS (F&amp;A) (SPECIFY RATE AND BASE)</b>				
Rate: 70.0% Base: 3,355,461				
TOTAL INDIRECT COSTS (F&A)				
2,348,823				
<b>J. TOTAL DIRECT AND INDIRECT COSTS (H + I)</b>				
8,937,095				

## 2.7.1 CY 2017 Budget Justification

The primary funding source for operation of the seven user programs of the National High Magnetic Field Laboratory (NHMFL) remains the National Science Foundation (NSF) and funds provided through the participating institutions: the

Florida State University, the University of Florida, and the Los Alamos National Laboratory.

According to the NHMFL Program Officer, funding for FY 2017 will be funded in a minimum of two increments. If the funding increments can be

# Chapter 2 – Laboratory Management

held to two increments, the NHMFL will be able to better maintain uninterrupted user program operations and efficient use of finite resources and staffing. Optimal use and timing of expenditures will require careful planning for personnel, equipment, materials and supplies, travel, sub-awards, and electricity. Specific rationale for the 2017 budget follows:

## A. Personnel

The current level of staffing is required for the Lab to maintain user support, technology development, and science (NHMFL User Collaboration Grant Program) activities. Actual salary rates, plus a 3% increase, of existing NHMFL Staff have been used in the cost calculations. Florida State University's fringe benefit rates for permanent staff fluctuate depending on the benefit package chosen by the staff member. Therefore, an average fringe benefit rate of 35.4% is used to calculate the cost of fringe benefits for permanent staff. This rate includes social security, Medicare, health insurance, retirement, workers compensation, and terminal leave payout. FSU's fringe benefit rate for postdocs and non-students is 2.75% plus the cost of health insurance. The fringe rate for graduate and undergraduate students is 1.3% plus the subsidy for health insurance for graduate students. The subsidy cost for graduate student health insurance of \$1,012, \$1,212, or \$1,662 is based on the graduate student's FTE. In accordance with state law, Florida State University is providing health insurance coverage to OPS employees working 30 hours or more per week. The annual rate for family insurance is \$16,555 per employee while individual coverage is \$7,714 per year.

Since the NHMFL is a large, complex, multidisciplinary user facility, there is a requirement for a larger than normal level of research and non-research support staff. The faculty included in the budget are twelve (12) month specialized research faculty (not tenured or tenure track nine (9) month teaching and research faculty). Therefore, the effort of these research faculty and the effort of other research and administrative staff identified in this proposed budget exceed the NSF two month limitation associated with regular tenure/tenure track nine (9) month teaching faculty.

Due to the mission of the NHMFL, a higher level of administrative support is required to ensure successful operation of the facility. The primary responsibility of the NHMFL's administration is to ensure

compliance with the terms and conditions of our sponsored project while facilitating the day-to-day work for our users and scientific staff. The NHMFL is an extension of Florida State University. Because of the requirements of the NSF Cooperative Agreement, the administrative staff exceeds the level of staff routinely provided by the university. To insure performance, the staff offers direct, on-site services to the user and research community. The administrative staff is responsible for a core set of activities including budget and finance; accounting; purchasing, shipping and receiving; human resources; facilities management and engineering; as well as safety, security, and environmental protection. In addition to central departments and activities, the user divisions have a program associate to support and facilitate the non- science related tasks required to ensure that the User Program's operational needs are met. The services being provided by administrative staff are accrued solely for the benefit of the NHMFL core mission and exclusively support the NSF Cooperative Agreement. The total FTE required for secretarial and clerical services, and administrative staff classified as Other Professionals to directly support this NSF project is 7.16 FTE.

## B. Equipment

Equipment funds of \$931,682 will be devoted to mitigating equipment failures, purchasing new and updated equipment for the User Programs, and new magnet technology. Within the five years of this grant, the overwhelming majority of equipment funds represent essential expenditures to maintain and enhance user support.

Anticipated major equipment purchases are listed below by NHMFL division. Note the total for the equipment listed below is more than our budget for equipment purchases. A portion of the equipment funds will be allocated to needs that arise throughout the project that cannot be specifically determined at this date. This need is based on historical experience in having to address unanticipated needs throughout the project period. We believe this to be a conservative estimate to cover those needs that will arise.

Throughout the year, equipment purchases will be approved based upon users' scientific needs and the progress of major projects. Our highest priority is to continue to maintain the highest quality of user science.



# Chapter 2 – Laboratory Management

<b>Magnet Science and Technology</b>	
Split Magnet Rotation	350,000
Pulsed 100T Wire Conductor	150,000
Large Bore Resistive Magnet	55,000
28MW Magnet	1,050,000
32T Coil and System Integration	21,000
YBCO Tape for 40T Magnet	500,000
Instrumentation	20,000
<b>Applied Superconductivity Center</b>	
Thermal Gravimetric Analysis/Differential Thermal Analysis System	60,000
Vibrating Polisher	7,000
Diamond Saw	9,000
Keithley 2182 and 2440 Source Meter	8,000
Leak Detector	25,000
<b>DC Field Facility</b>	
Keithley 2450 Source Meters	15,000
Lock in Amplifiers SR124	14,000
LakeShore 372 AC Resistance Bridge	19,000
Current and Voltage Preamps	20,000
Voltmeters/Electrometers	20,000
Lock in Amplifiers SR 865	24,000
Microscopes	24,000
Power Conditioners	20,000
<b>Nuclear Magnetic Resonance</b>	
2.5 GHz Digital Oscilloscope	25,000
Gyrotron Chiller	15,000
500-1000 MHz 500W Amplifier	38,000
FTS Unit	20,000
<b>Ion Cyclotron Resonance</b>	
High Pumping Speed Turbo-Molecular Pumps (2)	70,000
Atmospheric Pressure Ion Mobility Source	80,000
RF Drivers for Multipoles	50,000
<b>Electron Magnetic Resonance</b>	
340 GHz High Power Source for Pulsed Spectrometer	50,000
400 GHz Microwave Source for the Homodyne Spectrometer	65,000
Microwave Source Replacement for the Bruker Machine	14,000
115 GHz Multiplied Source	25,000
170-260 GHz Frequency Doubler	7,000
Nd-YAG Laser Flashlamp Replacement	5,000
Laser Head with Power Supply (Innolas)	28,000
Mossbauer Gamma Source	8,000
100L Liquid Helium Dewar	5,000

# Chapter 2 – Laboratory Management

## C. Travel

Travel budget levels are required to maintain a basic level of user support, technology development, and science activities. Total dollars of \$193,399 are requested for domestic travel while \$42,467 is requested for foreign travel. Based on conference attendance and research performed in the past, the following expenditures are anticipated for travel to the following countries in 2017:

**Scientific Conferences** held in the United States, United Kingdom, China, Netherlands, France, Greece, Japan, India, Turkey, and Spain.

**Workshops** held in in the United States, United Kingdom, Netherlands, and France.

**Research** held in the United States, United Kingdom, France, and Spain. A sample of the project travel plans for FY 2017 is:

- Applied Superconductivity Conference
- CEC-ICMC 2017
- M & M 2017
- EUCAS 2017
- Electronic Materials and Applications Conference
- International Cryogenic Engineering Conference
- International Conference on Superconductivity and Magnetism
- International Low Temperature Conference
- Low Temperature Superconductor Workshop
- APS Conference
- 2017 International Machine Tool Show
- International Conference on Low Temperature Physics
- Microscopy and Microanalysis 2017
- Experimental NMR Conference
- PITTCON
- American Chemical Society Fall Meeting
- American Society for Mass Spectrometry
- Visitor/User Travel
- American Chemical Society National Conference
- Goldschmidt Conference
- Southeastern Magnetic Resonance Conference
- International Society for Magnetic Resonance in Medicine
- ICM Conference
- International Society of Magnetic Resonance (ISMAR) Conference
- Gordon Research Conference of Magnetic Resonance

- Various Vendor Visits
- Meetings at the National Science Foundation

## D. Participant Support – Stipends Research for Undergraduates:

This item is an estimate of the budget required to support the Research Experience for Undergraduates (REU) Program. Although students are recruited from across the United States, the requested funding is an estimate. If participants include students from FAMU or FSU (local students), housing and travel expenses are not incurred. This creates the flexibility to support more students than originally anticipated.

This summer internship program matches qualified undergraduate students with scientists and researchers at the NHMFL's three sites. The ten-week research experience offers unique opportunities to explore science at the extremes of magnetic field, pressure, and temperature. Students explore contemporary science and engineering issues, working alongside some of the finest scientists, magnet designers, and engineers in the world. Each student accepted by the program receives a stipend. The student also receives travel support and housing unless the student is local.

The NHMFL offers a wide range of science, math, engineering, and interdisciplinary experiences in physics, chemistry, biological sciences, geochemistry, materials science, and magnet science and engineering. Summer interns, working closely with their faculty mentors, are thoroughly integrated into these research and development activities. Students broaden their knowledge of the diverse research that takes place here by attending weekly seminars and colloquia.

In 2016, there were 20 students; 14 males and 6 females. Of the 20 participants, 10 were underrepresented minority groups. Examples of student projects may be seen on the NHMFL website at <https://nationalmaglab.org/education>. In 2017, the goal is to continue our efforts to increase the number of students from underrepresented groups including women, African Americans, and Hispanic students. A special effort will be made to recruit students from HBCU, colleges and universities that serve a large percentage of African Americans, Hispanic, and other underrepresented students.

Costs: Approximately \$7,910 per student – includes \$5,000 stipend; \$2,310 housing; \$600 non-

# Chapter 2 – Laboratory Management

local travel; and a program total of \$2,058 for mentors to purchase various supplies required for scientific experiments. Excess travel allowance not paid to local participants enables the Lab to utilize these funds to increase the number of participants. The total amount of funds requested to support the REU program is \$106,158 based on fifteen participants.

## *Research for Teachers:*

The Research Experience for Teachers (RET) Program is a six week summer residential program that gives K-12 teachers the chance to participate in the real-world science of cutting-edge magnetic field research. Through various program activities, the teachers develop strategies and resources to translate the experience into material for their classrooms. In 2016 there were 10 teachers; 3 males and 7 females. Of the 10 participants, 5 were underrepresented minority groups.

The cost of the program is approximately \$6,510 per teacher which includes a stipend, housing, and non-local travel. The funding for the RET Program will be split between the NSF budget and other funding. NSF funds will be used for stipends, totaling \$36,000, while all other expenses will be covered by funds from other sources.

## *E. Other Direct Costs: Materials and Supplies*

Approximately 1,615 scientists annually request 'magnet time' for performing research and subsequently publishing the results of their research in premier scientific journals. Expenses for materials and supplies of \$2,485,713 are necessary due to the complexity of operating and maintaining a large, international user facility while supporting the development of new magnet technology for the science community. In many cases these items may be charged to another source; however, since the NHMFL is an NSF funded user facility, these charges are directly related to the scope set forth in the Cooperative Agreement.

Specific purchases in this category include, but are not limited to:

- Helium and nitrogen are required components for the operation of the assorted magnets located within the Lab. These commodities represent a significant amount of the materials and supplies budget.
- Computer hardware and software which are dedicated to or support scientific instrumentation in the user facility or are

required for experiment control, data acquisition, or scientific analysis. As a user facility, the NHMFL supports a variety of computing systems and services for international, academic, and government researchers which require computing hardware and specialized software. These costs are necessary to support the operations of a user facility and can be identified readily with the NSF Cooperative Agreement.

- Instrumentation and Lab equipment such as voltmeters, current sources, thermometers, pumps, glassware, tape, etc. are required for various Labs used by researchers and users.
- Chemicals and raw materials such as acids and bases, reagents, metal, plastics, etc. are required for researchers to conduct their research.
- Safety equipment such as safety glasses, gloves, fall protection, harnesses, electrical safety gear, etc. These items are required to ensure the safety of the staff.
- Postage expense is used for activities required by the NSF Cooperative Agreement such as: MagLab Reports and other research reports to national and international users and prospective users, other documents deemed necessary to meet the needs of our users and to further our commitment to education, research, and learning. In order to support education at all levels, K-12, technical, undergraduate, graduate, and postdoctoral, the dissemination of educational materials through the mail becomes greater than customary in an academic department. These mailings are readily identifiable and significantly exceed the level of postage normally associated with other sponsored projects.

## *F. Sub-Awards*

The proposed level of funding is required to maintain the level of operations for the AMRIS, High B/T, and Pulsed Magnet User Programs that promote magnet-related research for the scientific user community. Detailed budgets and budget justifications for each individual division reflect their specific spending plan.

A sub award to Steven Beu, Consultant, will be funded from the Ion Cyclotron Resonance (ICR)

# Chapter 2 – Laboratory Management

User Program fund. As in the past, Dr. Beu will continue to consult with the ICR Program on the development of new ion transfer optics and techniques for improved ion transmission and decreased time-of-flight mass discrimination in FT-ICR mass spectra.

## G. Other Direct Cost

*Electricity* – Funds of \$1,800,000 is designated for the electrical costs for magnets. This cost is an extraordinary cost for electrical power and represents unlike circumstances since the magnets require large amounts of electricity to operate. The electrical costs attributed to the magnet operation, which has been direct charged to the NSF Core since NSF first began funding the Lab, is not included in FSU's indirect cost but has been treated as other direct costs charged to grants and included in our research base when preparing our F&A rate proposal. These costs represent unlike circumstances because the electrical power does not support the general power needs required of the buildings and Labs, i.e. overhead lights, small office and Lab equipment, room heating and cooling, etc. The electrical power usage for the magnet operation is separately metered from other normal electrical demands. Because the magnet operations require such a huge amount of power, this is a cost directly required in order to support a user facility. The amount of available user time will be impacted without these funds to assist in covering the costs of magnet operations.

Florida State University receives two power bills each month. One is the Electric Contract (Interruptible) and the other is the Electric Large Demand (Firm). These bills are generated from two different sets of meters. The electrical system is segregated into (1) the power required to run the high power DC Field magnets (Interruptible) and (2) all power that is for general building operations (lighting, heating and cooling, computers and any scientific equipment) (Firm). For the magnets (Interruptible) the NHMFL has a special rate, since the City of Tallahassee can contact the Lab and interrupt the power for magnets if the need occurs. Florida State University pays for the Electric Large Demand (Firm) from university funds, while the

Electric Contract (Interruptible) is paid with NSF funds since that electricity is directly used for magnet operations.

*Tuition* – Florida State University policy requires that In-State tuition waivers be paid and tuition rates do not include student related fees. For FSU FY 2017-2018, the tuition rate per hour is \$407.55. Graduate students are required to be enrolled for nine hours each semester. The cost of tuition for nine hours per semester is \$3,668. These costs, which are the standard tuition rates for FSU, were used to calculate the tuition for each Graduate Student based on the length of their appointment. The total cost of tuition for Graduate Students for FY 2017 is \$65,594. Tuition rates and annual increases are set annually by the Florida Legislature and the Florida State University Board of Trustees. The current approved rate of increase is 1.0% per year.

*User Collaboration Grant Program (UCGP)* – The National Science Foundation has charged (through the Cooperative Agreement) the NHMFL with developing an in-house research program that utilizes the NHMFL facilities to carry out high quality high field research at the forefront of science and engineering; and advances the NHMFL facilities and their scientific and technical capabilities. To this end, the NHMFL's Users Collaboration Grants Program seeks to achieve these objectives through funded research projects of normally 2 years duration in the following categories:

- Collaborations between internal and/or external investigators that utilize their complementary expertise;
- Bold but risky efforts which hold significant potential to extend the range and type of experiments;
- Initial seed support for new faculty and research staff, targeted to magnet Laboratory enhancements.

The UCGP strongly encourages collaboration between NHMFL scientists and external users of the NHMFL facilities.

The UCGP research awards are normally funded for two years. Since the current award ends on December 31, 2017, only Year 2 of the current awards will be funded. As in past years, a UCGP proposal solicitation will take place in 2017. The awards from

# Chapter 2 – Laboratory Management

this proposal solicitation will be funded in early 2018 under the new renewal award.

## *E. Indirect Cost*

Per the Florida State University's Indirect Cost Rate Agreement, the approved indirect cost rate for NHMFL awards is 70% modified total direct costs (MTDC).

## 2.7.2. CY 2017 Budget Justification UF High B/T Facility

### *A. Personnel*

*Neil S. Sullivan (0.5 summer months)* is the Director of the High B/T Facility and is responsible for the overall operation of the Ultra-Low Temperature program of the NHMFL. He is a full-time professor of physics at the University of Florida and also directs the University of Florida Microkelvin Laboratory in which the High B/T Facility is located.

*Chao Huan (12 calendar months)* is a research scientist who operates both Bay 2 and Bay 3 of the Microkelvin Laboratory for external users. He is directly responsible for co-ordination with new users and the planning of experimental cells for installation on the nuclear demagnetization refrigerators.

*Andrew Woods (12 calendar months)* is a postdoctoral fellow who leads the development of new instrumentation for users and who assists with the operation of Bay 3 for users. He also assists Chao Huan in the design and setup of experiments for users.

A *graduate student* will be appointed (12 calendar months) to conduct research on quantum matter at ultra-low temperatures that will involve development of specialized instruments to be used for measurement of magnetic susceptibilities at very low temperatures.

### *B. Fringe Benefits*

The fringe benefits at the University of Florida are 26.9% for faculty and 20.4% for postdoctoral and graduate student appointments.

### *C. Tuition*

Item G6 designates the tuition costs required by the University of Florida for one graduate student.

### *D. Equipment*

We have budgeted \$31,000 for the purchase of new equipment in the current High B/T facility to support advanced instrumentation for the NHMFL external User Program. This equipment includes: High precision current and voltage sources (\$9,500), digital recording instruments and digital voltmeters and

oscilloscopes (\$8,700), and RF amplifiers, generators and detectors (\$12,800).

### *E. Travel*

We have budgeted \$2,000 for domestic travel. This includes partial support to assist 2 people to attend the annual March Meetings of the American Physical Society in New Orleans, USA in 2017. Also budgeted is \$2,000 for international travel to partially support attendance of 2 people at the International Low Temperature Conference to be held in Gothenberg, Sweden in 2017.

### *F. Materials & Supplies*

We have budgeted for \$90,974 for materials and supplies. The principal cost is that for liquid helium which is provided at a cost of \$2.50 per liquid liter and we are budgeting for an annual consumption of 25,000 liters for operation of Bay 2, Bay 3 and the fast turn-around facility for at least 300 day for a total liquid helium cost of \$62,500. We have also budgeted \$28,474 for small items such as tools, small electronic components, vacuum and gas plumbing, and miscellaneous supply items.

### *G. Indirect Costs*

The University of Florida charges 52.5% indirect costs on the total of direct charges minus the sum of equipment costs and graduate student tuition.

## 2.7.3. CY 2017 Budget Justification UF AMRIS Facility

### *A. Personnel*

*Joanna Long (3.0 cal)* is AMRIS Director and co-PI of the subcontract and is responsible for the overall operation of the AMRIS User Program, distributing the NHMFL supply money to pay for AMRIS fees, and annual reporting. She also directs the dynamic nuclear polarization technology program to enhance the NHMFL external User Program. She has 3 months total effort, divided into 1.8 months for AMRIS and 1.2 months for the DNP initiative.

*Thomas H. Mareci (1.2 calendar months)* is the AMRIS Associate Director and directs the high field structural MRI program and MRI technology development to enhance the NHMFL external User Program.

*Matthew E. Merritt (1.2 calendar months)* directs the high sensitivity NMR technology program to enhance the NHMFL external User Program.

*Glenn Walter (1.2 cal)* leads the molecular imaging technology program to enhance the NHMFL external User Program and serves on the Science Advisory board.

# Chapter 2 – Laboratory Management

*Gail Fanucci* (1.2 cal) is a member of the Science Advisory board and develops technology in the DNP program; she is also the UF liaison between the EMR and NMR groups of the NHMFL.

*Steve Blackband* (0.6 cal) leads the microimaging technology program to enhance the NHMFL external User Program.

*Marcelo Febo* (0.6 cal) leads the functional MRI program to enhance the NHMFL external User Program and serves on the diversity committee.

*Denise Mesa* (3.6 cal) is responsible for the reporting and secretarial activities necessary to run the NHMFL external User Program.

*Malathy Elumalai* (12 cal) is the RF engineer responsible for designing, constructing, testing, and maintaining unique RF coils for the horizontal animal imaging systems and the WB 750 system within the AMRIS facility as well as coordinating with new RF projects pursued by the NMR probe development group in Tallahassee. Funds for this position are requested under “materials and supplies” due to this position falling under the AMRIS auxiliary.

## B. Equipment

We have budgeted \$100,000 each year for the purchase of new equipment in the AMRIS facility to support the NHMFL external User Program. This includes equipment for 8 spectrometers, an RF engineering Laboratory, and staff scientists. Typical items include new RF or gradient amplifiers, new NMR probes, RF frequency generators, network analyzers, and animal monitoring equipment. In FY 2016, we plan to direct these funds to upgrading the digital and RF electronics on our world unique 11T / 40 cm MRI/S system.

## C. Travel

1. The travel budget in the NHMFL subcontract includes funds for the NHMFL investigators affiliated with the AMRIS facility to travel to the requisite annual meetings for the NHMFL NSF site visit, the Users Committee meeting, an internal strategic planning meeting, and the External Advisory Committee meeting. Each of these is estimated at \$400 per person to cover two nights hotel, the meeting registrations, and travel to Tallahassee from Gainesville. Two people, four meetings totals \$3,200.
2. Three members of our Users Committee (non-NHMFL investigators) travel to the annual

Users Committee meeting. Each of these is estimated at \$1,000 to cover airfare, two-three nights hotel, and meeting registration. This totals \$3,000.

3. Drs. Long, Mareci, and Febo also make about four trips per year to the NSF, Labs the NHMFL is collaborating with, HBCUs for outreach activities, and vendors to discuss designs and specifications. Each of these trips is estimated at \$750 per person to cover airfare, one night hotel, and meals. Four trips total \$3,000.
4. Drs. Long, Mareci, Merritt, Blackband, Walter, Febo, and Fanucci travel to Tallahassee for face-to-face meetings as needed with NHMFL colleagues. Most communication is through email and skype, but approximately 10 trips per year total are made. Each of these trips is estimated at \$250 for one person to cover hotel, meals, and transit to Tallahassee. This is a total of \$2,500.
5. Both Dr. Long and Dr. Mareci will attend the Experimental NMR Conference to publicize technical developments at the NHMFL and our User Program. The AMRIS RF engineer, Malathy Elumalai, will also attend to present new capabilities developed for high field animal imaging. This is the premier conference of the NMR community in the U.S. This year the conference is in April in Monterrey, CA. Each person is estimated to cost \$2,500 for airfare, registration, hotel and meals. This is a total of \$7,500.
6. Drs. Mareci, Merritt, and Walter will attend the 25<sup>th</sup> Annual Meeting of the International Society for Magnetic Resonance in Medicine to publicize technical developments at the NHMFL and our User Program. This is the premier international conference of the MRI community. This year the conference is in April in Honolulu, HI. The cost for this conference is estimated at \$2,500 per person for airfare, registration, hotel, and meals. This is a total of \$7,500.
7. Dr. Long and Dr. Fanucci will be attending the 20th meeting of the International Society of Magnetic Resonance in Montreal, Canada, July 23-28, 2017. This is the premier international conference on magnetic

# Chapter 2 – Laboratory Management

resonance for 2017. They will be presenting new technology developments at the NHMFL in DNP and MRI/S and expansion of the User Program into biological EMR. The cost for this conference is estimated at \$2,500 per person for airfare, registration, hotel and meals. This is a total of \$5,000.

8. The total of all travel listed above is \$31,700. A contingency fund of \$1,300 to cover cost overruns is also budgeted, since all trips listed above were conservatively estimated. This brings the total travel budget to \$33,000.

## D. Materials and Supplies

The AMRIS Facility is a core facility at the University of Florida which operates under federal cost accounting standards. It currently has an annual operating budget of just over \$1.13 M. This includes the seven high field NMR and animal MRI systems which are part of the NHMFL user facility, and a 3T/90 cm clinical MRI scanner used in human and large animal research, which does not receive staff or equipment support from the NHMFL grant. Of the AMRIS operating budget, \$100,000 earmarked for equipment and \$343,000 for operations, listed under “materials and supplies,” comes from the NHMFL subcontract. The funds under “material and supplies” are specifically allocated to pay for (a.) external user projects (\$200,000), which come through the NHMFL user portal, and (b.) development projects (\$143,000), as identified by the renewal proposal and approved UCGP projects; this includes funding for the RF engineer listed under personnel who is dedicated to developing new coils and keeping existing coils operational.

AMRIS is administered in full compliance with federal cost accounting standards and the rates for instrument time and AMRIS staff consulting are calculated in a manner that is straightforward and fair: real costs divided by use set the rates for each individual instrument and all expenses are assigned to individual instruments. This includes the daily operation costs of the instrument, service contracts, and staff FTEs dedicated to the instrument management and repairs. Our accounts and billing are independently reviewed every year with rate adjustments based on three-year averages of operating costs. The NHMFL subcontract funds external user fees (i.e. for investigators outside of UF, FSU, or LANL) and

development projects to pay for staff and instrument time, which allows AMRIS to run the NHMFL User Program within the CAS structure.

## E. Indirect Costs

The University of Florida charges 52.5% indirect costs on the total of direct charges minus the sum of equipment costs and graduate student tuition.

## 2.7.4. CY 2017 Budget Justification Los Alamos National Laboratory

We intend to operate the Pulsed Field Facility at Los Alamos National Laboratory to provide NHMFL users with access to pulsed magnetic fields for reviewed and approved research. We will continue to develop state-of-the-art pulsed magnet systems and operate them for qualified users. The total FY17 budget of \$7,400,000 will be used for development of advanced high magnetic field generation systems, operation of the User Program, which includes salaries, materials and supplies, consumables such as liquid cryogens, and a travel budget. Fringe benefit costs are included in the salary amounts.

## A. Personnel

*Charles H. Mielke* (0.6 cal.) is the Director of the Pulsed Field Facility and is responsible for the overall operation of the Los Alamos National Laboratory based NHMFL-PFF. He is a full time Research and Development manager at LANL based at the NHMFL-PFF in Los Alamos, NM, his salary is paid for by LANL for the purpose of directing the facility and managing the personnel. A nominal level of support is provided from the core program for scientific developments that benefit the user community or research field relating to the core mission of the NHMFL. *Scientific User Support Staff* (70.32 cal.) will be assigned to directly working with qualified NHMFL-PFF users to conduct experiments in high magnetic fields. The expert scientific staff possess demonstrated competencies in magnetotransport, magnetic susceptibility, magneto-optical spectroscopy, thermal transport, radio frequency contactless transport, specialized non-metallic cryogenic systems and pulsed field diagnostic and analysis specializations. This skill set from this group of 9 individuals is first rate in the world for state-of-the-art pulsed magnetic field experimentation. Working to enable users to return home with a complete set of data that is analyzed

# Chapter 2 – Laboratory Management

and interpreted is an essential function of the NHMFL-PFF.

*Engineering Staff* (26 cal.) consists of two individuals who are responsible for the development of pulsed magnet systems and the engineering support/operation of the 1.43 billion watt generator system located at LANL. The world class 100 tesla Multi-Shot Magnet set the world record for highest non-destructive pulsed magnetic field and, more importantly, delivered nearly 1,000 high-field pulses for users. This system requires expert attention and monitoring to safely operate it and maintain it for future experiments. The insert magnet system requires highly specialized design and optimization and monitoring. The NHMFL-PFF team of two scientist/engineers delivers for users, and they are fully committed to the smooth operation of this world-class system. Their participation and dedication is essential.

*Technician Support* (96.96 cal.) at the NHMFL covers direct interfacing with users to provide needed technical resources for a successful user experience, infrastructure support to maintain our user “magnet cells” and ancillary equipment, two technicians provide support here. All of the 65 tesla user magnets (our current workhorse magnets) are manufactured fully in house because these are highly specialized units under tremendous stresses each shot. The workhorse magnets are fired approximately 7,000 times each year for users and we need to replace these magnets about every 1,000- 1,200 shots. Two technicians are dedicated to this effort currently. The operation and maintenance of the 1.43 billion watt generator system is used for the 100 tesla multi-shot magnet and the 60 tesla long-pulse magnet. This generator system can safely deliver up to 600 million Joules of energy in its current configuration and is arguably the best and safest way to deliver the very large electrical energy pulse to our largest magnet systems. Three technicians are dedicated to operation of this system and the maintenance of the generator. The NHMFL-PFF has achieved first ever status on several magnet systems in part due to this LANL resource made fully available to the NHMFL-PFF program, and our technicians are highly trained professionals needed to safely operate this system to deliver magnet pulses of immense electrical energy magnitudes. A total of seven technicians are required to operate the NHMFL-PFF as described above.

*Postdocs and Students* (6.0 cal.) are an important aspect of the NHMFL-PFF. A total of ten postdocs and students are currently active at the NHMFL-PFF while the core funding is currently providing only a fraction of their financial support. Often a postdoc or student will be attached to a science staff member and funded through another research channel such as LANL sponsored LDRD grants or DOE-BES channels. Students that are funded through core NSF program support are of strategic design. The funded students are engaged in strategic scientific areas or targeted diversity development opportunities.

*Contractor* (15.0 cal.) support is highly focused and relatively temporary in nature at the NHMFL-PFF. Contracts are annually renewed and may be task specific. An effort of 7.0 cal. is directed towards magnet design and 3-D modeling, working very closely with the design engineers responsible for bringing our unique and world-leading pulsed magnet designs forward into the future and ahead of the competition. The generator system requires the precise development and updating of its extensive control system and an effort of 8.0 cal. is directed toward that project and the maintenance of the generator control system. That effort is essential as control components age beyond useful repair life cycles and must be repaired or replaced with safety certified components. A total of more than 5,000 diagnostic signals are actively monitored and controlled continuously for every pulse of our 1.43 billion watt generator system, and the controls engineer contractor is essential for completing the systems upgrades and maintenance to the level we need for sustained operations.

## *B. Equipment*

A total of \$54,000 (unburdened estimated cost) is currently budgeted for equipment. The equipment will include power electronics, control electronics, high voltage power supplies and monitoring, and systems modules and components for system integration. Specific program equipment may be requested as supplemental budgetary requests should the need arise.

## *C. Materials & Supplies*

A total of \$999,813 is needed for materials and supplies. This figure is determined by considering historical rates of consumption of products like liquid cryogenics and magnet winding materials and allocating a flexible amount of remaining funds from our



# Chapter 2 – Laboratory Management

budget positioning projections based on labor planning so that low-cost consumables may be purchased to enable the scientific staff, technicians, postdocs, and students to have the flexibility to develop new pulsed field probes and measurement techniques based on general materials and consumables for the users of the NHMFL-PFF. Fiberglass rods, thermometer chips, fiber optical cable, and machined specialized parts are broadly used for these developments. The staff will spend a significant portion of their time using these materials for developing new research probes for pulsed field diagnostic developments that are fully integrated into the User Program and used by qualified users.

## D. Travel

A total of \$45,000 has been budgeted for domestic travel. This includes \$35,000.00 each year for domestic travel for experimental user support efforts at the NHMFL-DC Field Facility (a total of 6 trips to the DC Field facility are budgeted each year at \$2,000 each), the APS March meetings (12 people attending at \$1,700 each), and two domestic scientific conferences (three people attending at \$867 each). We anticipate a total of approximately \$10,000 to be spent on international travel over the next year of the grant cycle for attendance to relevant scientific conferences and broader dissemination of NHMFL technical and scientific accomplishments. LANL institutional funds will be used for scientific outreach efforts both domestically and internationally, allowing the NHMFL to leverage LANL commitment to the

accomplishments of the NHMFL as a partner in success.

## 2.7.2.5. CY 2017 Budget Justification S.C. Beu Consulting

Dr. Steven Beu will perform objective scientific analysis in support of new development in Fourier Transform Ion Cyclotron Resonance (FT-ICR) mass spectrometry, including but not limited to:

- Development of new methods of ion injection into high magnetic fields by use of rf multipole ion guides,
- Simultaneous excitation and detection for enhanced mass resolving power and quantitation,
- Combined electron capture and infrared multiphoton dissociation (ECD/IRMPD) in narrow bore (<110 mm) magnets,
- Minimization of m/z discrimination due to time-of-flight dispersion during ion injection into the ICR cell, and
- Development and testing of new ICR cell geometries.
- Integration of all developed technologies into a 21 T FT-ICR mass spectrometer. Dr. Beu will conceive new methods, develop models and experiments to test the methods, collect and interpret data, prepare manuscripts, present his findings at national meetings, and recommend future directions.

Services will be billed quarterly at a rate of \$100 per hour.

Total time billed for the 2017 calendar year will not exceed 550 hours for a total amount payable not to exceed \$55,000.

**Table 3: Statement of Residual Funds - CY 2017**

177,317,098		NSF Budget Allocation for CY 2013-2017
<b>Reconciliations</b>		
(170,242,851)		Total Expenses and Encumbrances, including Indirect Cost
	7,074,247	Net Available Budget
6,937,095		Supplement Budget Balance as of December 31, 2017
	137,152	Total Budget Residual
<b>Obligations</b>		
(31,541)		Miscellaneous Allocated Unencumbered Purchases
(504)		2017 Fall Semester Matriculation Fees
(78,944)		Pro-rated December Electricity
(19,610)		Workers Comp and Terminal Leave Payout for December 2017
<u>(41,689)</u>		Indirect Cost for Obligated/Unencumbered Expenses
(172,288)		Total Obligations/Unencumbered Expenses
<b>Projected Deficit</b>	(35,136)	

**Notes:** Supplement funding was received in December 2017 to cover expenses for January-March 2018. Obligations represent allocated costs not yet expended. Deficit will be covered by other university funds.

# Chapter 2 – Laboratory Management

**Table 4: Statement of Expenses and Encumbrances (January 2013 through December 2017)**

	2013-2017		As of 12/31/17		2017		As of 12/31/17	
	EXPENSED	ENCUMBERED	TOTAL COSTS 2013-2017	EXPENSED	ENCUMBERED	TOTAL COSTS 2017		
A. SENIOR PERSONNEL: PI/PD, Co-PI's, Faculty and Other Senior Associates	16,034,678	185,766	16,220,444	3,939,795	185,766	4,125,561		
B. OTHER PERSONNEL								
1. POSTDOCTORAL ASSOCIATES	2,023,005	14,787	2,037,793	497,062	14,787	511,849		
2. OTHER PROFESSIONALS (TECHNICIAN, PROGRAMMER, ETC.)	12,650,240	133,958	12,784,198	3,108,223	133,958	3,242,181		
3. GRADUATE STUDENTS	1,417,363	8,960	1,426,323	348,253	8,960	357,213		
4. UNDERGRADUATE STUDENTS	893,095	749	893,843	219,438	749	220,186		
5. SECRETARIAL - CLERICAL (IF CHARGED DIRECTLY)	646,209	6,410	652,619	158,776	6,410	165,187		
6. OTHER	-	-	-	-	-	-		
TOTAL SALARIES AND WAGES (A + B)	33,664,590	350,631	34,015,221	8,271,546	350,631	8,622,177		
C. FRINGE BENEFITS	10,030,159	103,583	10,133,742	2,621,442	103,583	2,725,025		
A-C. TOTAL SALARIES, WAGES AND FRINGE BENEFITS	43,694,749	454,214	44,148,963	10,892,988	454,214	11,347,202		
D. TOTAL EQUIPMENT	9,569,383	3,223,456	12,792,838	3,880,235	3,223,456	7,103,691		
E. TRAVEL								
1. DOMESTIC	1,054,537	3,115	1,057,652	184,649	3,115	187,764		
2. FOREIGN	389,978	3,308	393,286	104,122	3,308	107,430		
F. PARTICIPANT SUPPORT								
1. STIPENDS	633,697	-	633,697	127,101	-	127,101		
2. TRAVEL	16,943	-	16,943	-	-	-		
3. SUBSISTENCE	72,853	-	72,853	14,360	-	14,360		
4. OTHER	-	-	-	-	-	-		
TOTAL PARTICIPANT COSTS	723,493	-	723,493	141,461	-	141,461		
G. OTHER DIRECT COSTS								
1. MATERIALS AND SUPPLIES	12,557,613	1,414,905	13,972,518	3,339,955	1,414,905	4,754,859		
2. PUBLICATION/DOCUMENTATION/DISSEMINATION	-	-	-	-	-	-		
3. CONSULTANT SERVICES	-	-	-	-	-	-		
4. COMPUTER SERVICES	-	-	-	-	-	-		
5. SUBAWARDS	45,500,005	748,649	46,248,654	6,345,484	748,649	7,094,132		
6. OTHER	9,156,074	-	9,156,074	2,759,447	-	2,759,447		
TOTAL OTHER DIRECT COSTS	67,213,693	2,163,553	69,377,246	12,444,886	2,163,553	14,608,439		
H. TOTAL DIRECT COSTS (A THROUGH G)	122,645,833	5,847,646	128,493,479	27,648,341	5,847,646	33,495,987		
I. INDIRECT COSTS (F&A)								
Base	57,696,877	1,875,542	59,572,419	14,521,713	1,875,542	16,397,255		
Rate: %	70%	70%	70%	70%	70%	70%		
TOTAL INDIRECT COSTS (F&A) - see notes 1 & 2	40,436,493	1,312,879	41,749,372	10,163,657	1,312,879	11,476,536		
J. TOTAL DIRECT AND INDIRECT COSTS (H + I)	163,082,326	7,160,525	170,242,851	37,811,998	7,160,525	44,972,523		

**Note:** Rebudgeting to increase IDC to 70% occurred in CY 2015. Supplement Funding received in 2017 for January - March 2018 expenses.

## 2.8. Cost Recovery Report

The NHMFL did not receive program income during CY 2017.

# Chapter 2 – Laboratory Management

## 2.9. Industrial Partners and Collaborators

### Industry

#### **89 North, Burlington, VT**

Scientists at the MagLab are working with applications specialists at 89 North to develop light-emitting diode technology for fluorescence microscopy. This collaboration involves testing the power output and usability of new high power LED technology in the emission region between 490 and 590 nanometers, a spectral region that is central to microscopy investigations.

*(MagLab contact: Eric Clark, Optical Microscopy)*

#### **Advanced Conductor Technologies, Boulder, CO**

The Applied Superconductivity Center and the Magnet Science and Technology division of the MagLab are collaborating with Advanced Conductor Technologies on the development and testing of Coated Conductor Stranded Cable (CCSC), using multi-layer spiraling tapes around a core, for magnet applications. Danko van der Laan, director of the company and associated with NIST/University of Colorado Boulder, is developing compact cables based on REBCO coated conductors, a high temperature superconductor. The ongoing collaboration involves detailed characterization of strands post-cabling and full-current testing of joints and coils.

*(MagLab contact: Huub Weijers, MS&T)*

#### **Agilent Technologies, Santa Clara, CA**

Agilent Technologies is entering the imaging arena with a new “Monolithic” laser combiner featuring acousto-optic-tunable filter (AOTF) control. The MagLab is collaborating with Agilent to prototype the laser system for use in super-resolution imaging.

*(MagLab contact: Eric Clark, Optical Microscopy)*

#### **Allele Biotech, San Diego, CA**

Allele is a manufacturer and distributor of fluorescent protein constructs made by Robert Campbell and Nathan Shaner. The MagLab is collaborating with Allele to develop fusion vectors of selected fluorescent proteins.

*(MagLab contact: Eric Clark, Optical Microscopy)*

#### **Andor-Tech, Belfast, Northern Ireland**

Andor-Tech is an imaging specialist involved with development of CCD camera systems designed to produce images at extremely low light levels. The

MagLab is collaborating with Andor-Tech to produce interactive tutorials describing electron multiplying CCD (EMCCD) technology and will work with the company to test new camera products in live-cell imaging.

*(MagLab contact: Eric Clark, Optical Microscopy)*

#### **B&B Microscopes, Pittsburgh, PA**

Scientists in the Optical Microscopy facility at the MagLab are working with B&B engineers to develop new live-cell imaging techniques using the wide array of products offered by the company. Eventually, an educational website is planned.

*(MagLab contact: Eric Clark, Optical Microscopy)*

#### **Bioprotechs, Butler, PA**

The MagLab is involved with Bioprotechs of Pennsylvania to develop live-cell imaging techniques using the company’s advanced culture chambers. The collaboration involves timelapse imaging of living cells over periods of 36-72 hours using techniques such as differential interference contrast, fluorescence, and phase contrast.

*(MagLab contact: Eric Clark, Optical Microscopy)*

#### **Bruker EAS GmbH, Hanau, Germany**

Bruker EAS is manufacturing accelerator quality Nb<sub>3</sub>Sn strands based on the powder-in-tube process that have the potential to provide the performance necessary for higher magnetic field upgrades to the Large Hadron Collider at CERN and the Applied Superconductivity Center is collaborating with Bruker and CERN to optimize the performance of the wire utilizing the electromagnetic testing and advanced microstructural and microchemical analysis facilities at the MagLab.

*(MagLab contacts: Chiara Tarantini, Peter J. Lee, and David C Larbalestier, ASC)*

#### **Bruker Biospin Corp, USA**

The EMR and NMR groups have entered into a collaborative effort with Bruker Biospin regarding the Dynamic Nuclear Polarization (DNP) program. In particular, the effort aims at improving Bruker’s recently acquired products (395 GHz gyrotron, 600 MHz/14.1T DNP probe) beyond their normal commercial uses by making technical modifications. The modifications allow

# Chapter 2 – Laboratory Management

the DNP instruments to be more User Program friendly without voiding the warranty.

*(MagLab contact: Stephen Hill, EMR)*

## **Bruker Biospin Corp., Billerica, MA**

The MagLab's NMR instrumentation program and Bruker Biospin collaborate on the development of Low-E probes for solid-state NMR in heat sensitive biological samples, such as proteins. Bruker Biospin manufactures a line of Efree probes based on the Low-E design developed at our Lab.

*(MagLab contact: Peter Gor'kov, NMR)*

## **Bruker Biospin, Faellanden, Switzerland**

Scientists in the MagLab NMR Program are working with Bruker Biospin and with Prof. Art Edison at the University of Georgia to improve the sensitivity of high-field solution NMR probes by utilizing high-temperature superconducting resonators.

*(MagLab contact: William Brey, NMR)*

## **Callaghan Innovations, Lower Hutt, New Zealand**

The Applied Superconductivity Center and the Magnet Science and Technology division of the MagLab are collaborating with researchers at New Zealand's Industrial Research Limited on the testing of Roebel-style cables based on REBCO coated conductors, a high-temperature superconductor. Testing of a 15-strand cable with transposed 5 mm wide strands is in preparation. Roebel-style cables represent one of three viable concepts for REBCO coated conductor cables suitable for high field magnets.

*(MagLab contact: Bob Walsh, MS&T)*

## **Chroma, Rockingham, VT**

A major supplier of Interference filters for fluorescence microscopy and spectroscopy applications, Chroma is collaborating with the MagLab to build educational tutorials targeted at fluorescence microscopy. Working in conjunction with Nikon, engineers from Chroma and scientists from the MagLab are examining the characteristics of a variety of filter combinations.

*(MagLab contact: Eric Clark, Optical Microscopy)*

## **The Cooke Corp., Romulus, MI**

Scientists at the MagLab are working with applications specialists at Cooke to field test the company's cooled and electron-multiplied scientific CCD camera systems. Demanding applications in quantitative image analysis

and high-resolution images are being explored, as well as time-lapse fluorescence microscopy and resonance energy transfer imaging.

*(MagLab contact: Eric Clark, Optical Microscopy)*

## **CoolLed Ltd., Andover, Hampshire, UK**

Scientists at the MagLab are working with applications specialists at CoolLed to develop light-emitting diode technology for fluorescence microscopy. This collaboration involves testing the power output and usability of new LED technology in the emission region between 490 and 590 nanometers, a spectral region that is central to microscopy investigations.

*(MagLab contact: Eric Clark, Optical Microscopy)*

## **Covance Research Products, Berkeley, CA**

Covance is a biopharmaceutical company involved with research and diagnostic antibody production. MagLab scientists are working with Covance researchers to examine immunofluorescence staining patterns in rat and mouse brain thin and thick sections using a wide spectrum of antibodies.

*(MagLab contact: Eric Clark, Optical Microscopy)*

## **Danfoss Turbocor Inc, Tallahassee, FL**

Danfoss Turbocor Inc. is a company specializing in compressors, particularly the totally oil-free compressors. The compressors are specifically designed for the heating, ventilation, air conditioning, and refrigeration (HVACR) industry and need high performance soft and hard magnet materials. The company and the Laboratory have a joint research project on selection, characterization, and development of permanent magnet materials and other materials for high-performance and environmentally friendly compressors.

*(MagLab contact: Ke Han, MS&T)*

## **Diagnostic Instruments, Sterling Heights, MI**

Scientists at the MagLab are working with applications specialists at Diagnostics to field test the company's new line of cooled scientific CCD systems. Demanding applications in quantitative image analysis and high-resolution images are being explored, as well as time-lapse fluorescence microscopy and resonance energy transfer imaging.

*(MagLab contact: Eric Clark, Optical Microscopy)*

# Chapter 2 – Laboratory Management

## ***Evrogen, Moscow, Russia***

Evrogen is a manufacturer and distributor of fluorescent protein constructs made by Dmitriy Chudakov and Vladislav Verkhusha. The MagLab is collaborating with Evrogen to develop fusion vectors of selected fluorescent proteins.

*(MagLab contact: Eric Clark, Optical Microscopy)*

## ***Lumencor Inc., Beaverton, OR***

The MagLab is collaborating with Lumencor to examine the spectra and output power of various illumination sources for microscopy including metal halide lamps, light engines, LEDs, and the LiFi illumination system.

*(MagLab contact: Eric Clark, Optical Microscopy)*

## ***Major Tool and Machine, Indianapolis, IN***

The US-ITER organization has contracted MTM as one of two primary vendors to supply large forgings of a super austenitic steel for the massive CS pre-compression structure (Tie Plates). The tie plate alloys, and their welds, are being studied and characterized here to ensure their performance and reliability. This is an example of industry relying on NHMFL's expertise and infrastructure to perform cryogenic temperature characterization of an advance alloy.

*(MagLab contact: Bob Walsh, MS&T)*

## ***MBL International, Woburn, MA***

Scientists at the MagLab are collaborating with MBL to develop new fluorescent proteins for live-cell imaging applications. These include both optical highlighters and fluorescence resonance energy transfer (FRET) biosensors.

*(MagLab contact: Eric Clark, Optical Microscopy)*

## ***Media Cybernetics, Silver Spring, MD***

Programmers at the MagLab are collaborating with Media Cybernetics to develop imaging software for timelapse optical microscopy. In addition, the Optical Microscopy group is working to add new interactive tutorials dealing with fundamental aspects of image processing and analysis of data obtained with the microscope.

*(MagLab contact: Eric Clark, Optical Microscopy)*

## ***Mevion Medical Systems, Littleton, MA***

Mevion is a pioneer in the development of proton radiation therapy systems for the non-invasive treatment of cancer. The center of the systems is the proton accelerator that utilizes low-temperature

superconductors. NHMFL provides engineering support to Mevion by assisting in qualification testing of full-scale high current superconductors in background fields at low temperatures. The tests require NHMFL's unique test facility designed for tests of large conductors in a 12 tesla split solenoid superconducting magnet system.

*(MagLab contact: Bob Walsh, MS&T)*

## ***Molecular Probes/Invitrogen, Eugene, OR***

A major supplier of fluorophores for confocal and wide-field microscopy, Molecular Probes is collaborating with the MagLab to develop educational tutorials on the use of fluorescent probes in optical microscopy.

*(MagLab contact: Eric Clark, Optical Microscopy)*

## ***Nanoelectro Ltd, Russia***

Nanoelectro Ltd and the National High Magnetic Field Laboratory have been developing new high-strength conductors for next generation magnets.

*(MagLab contact: Ke Han, MS&T)*

## ***Nikon, Melville, NY***

The MagLab maintains close ties with Nikon on the development of an educational and technical support microscopy website, including the latest innovations in digital-imaging technology. As part of the collaboration, the MagLab is field-testing new Nikon equipment and developing new methods of fluorescence microscopy.

*(MagLab contact: Eric Clark, Optical Microscopy)*

## ***Olympus America, Melville, NY***

The MagLab is developing an education/technical website centered on Olympus products and will be collaborating with the firm on the development of a new tissue culture facility at the MagLab in Tallahassee. This activity will involve biologists at the MagLab and will feature Total Internal Reflection Fluorescence microscopy.

*(MagLab contact: Eric Clark, Optical Microscopy)*

## ***Olympus Corp., Tokyo, Japan***

Investigators at the MagLab have been involved in collaboration with engineers at Olympus to develop and test new optical microscopy systems for education and research. In addition to pacing the microscope prototypes through basic protocols, the Optical Microscopy group is developing technical support and educational websites as part of the partnership.

*(MagLab contact: Eric Clark, Optical Microscopy)*

# Chapter 2 – Laboratory Management

## **Revolution NMR LLC, Fort Collins, CO**

Revolution NMR has licensed from FSU the Low-E probe technology developed at the MagLab in order to fabricate static NMR probes for biological (protein) samples. Additionally, the MagLab's NMR instrumentation program and Revolution NMR collaborate on the development of stators for magic angle spinning NMR.

*(MagLab contact: Peter Gor'kov, NMR)*

## **Scot Forge, Spring Grove, IL**

The US-ITER organization has contracted Scot Forge as one of two primary vendors to supply large forgings of a super austenitic steel for the massive CS pre-compression structure (Tie Plates). The tie plate alloys, and their welds, are being studied and characterized here to ensure their performance and reliability. This is an example of industry relying on NHMFL's expertise and infrastructure to perform cryogenic temperature characterization of an advance alloy.

*(MagLab contact: Bob Walsh, MS&T)*

## **Semrock, Rochester, NY**

The MagLab Optical Microscopy group is collaborating with Semrock to develop interactive tutorials targeted at education in fluorescence filter combinations for optical microscopy. Engineers and support personnel at Semrock work with MagLab microscopists to write review articles about interference filter fabrication and the interrelationships between various filter characteristics and fluorophore excitation and emission. In addition, MagLab scientists produce images of living cells with Semrock filter combinations.

*(MagLab contact: Eric Clark, Optical Microscopy)*

## **Siemens Medical Solutions USA, Inc., Malvern, PA**

The National High Magnetic Field Laboratory, Advanced Magnetic Resonance Imaging and Spectroscopy (AMRIS) Facility in the McKnight Brain Institute of the University of Florida (UF) has a master research agreement with Siemens to develop applications on Siemens MR systems installed in the University of Florida. Several UF research groups are involved in this research agreement and are developing new MRI methods and applications.

*(MagLab contact: Joanna R Long, AMRIS Facility)*

## **SuperPower Inc, Schenectady, NY**

The Applied Superconductivity Center and the Magnet Science and Technology division of the MagLab are collaborating with SuperPower Inc. on the

characterization of YBCO coated conductors. This material has the potential to transform the field of high-field superconducting magnet technology and is in an early stage of commercialization. We work to improve our understanding of this product in support of the NHMFL 32T project as well as to provide guidance to SuperPower on enhancing the quality of their product. We have also taken the lead in encouraging a Coated Conductor Round Table of users of coated conductors at which much information about the long length performance of coated conductors has been shared.

*(MagLab contacts: David C Larbalestier, Dmytro Abraimov, and Jan Jaroszynski, ASC and Huub Weijers, MS&T)*

## **Sutter Instrument, Novato, CA**

The MagLab is collaborating with Sutter to examine the spectra and output power of various illumination sources for microscopy including metal halide lamps and the LiFi illumination system.

*(MagLab contact: Eric Clark, Optical Microscopy)*

## **Thomas Keating Ltd, UK**

The EMR group has entered into a partnership with Thomas Keating (TK) Ltd in the UK as part of its program aimed at developing a new characterization tool, Dynamic Nuclear Polarization Nuclear Magnetic Resonance (DNP - NMR) at high fields (14.1T / 600 MHz). TK draws on tool-making skills to design and develop quasi-optical Terahertz systems and subsystems.

*(MagLab contact: Stephen Hill, EMR)*

## **Voltronics Corporation, Cazenovia, NY**

Advanced Magnetic Resonance Imaging and Spectroscopy (AMRIS) Facility in the McKnight Brain Institute of the University of Florida (UF) have collaborations with Voltronics in testing low temperature trimmer capacitors for cryogenic applications. The Dynamic Nuclear Polarization (DNP) probe that operates at 1K uses these capacitors to tune/match the coil resonance.

*(MagLab contact: Malathy Elumalai, AMRIS Facility)*

## **Waters Corporation, MA**

The ICR and Future Fuels Institute are a Waters Corporation, Center of Innovation and collaborate on advances in instrumentation for biological and petroleum applications. Instrument and ion source advances are provided to both facilities before their

# Chapter 2 – Laboratory Management

commercial release and allow for applications development well before mainstream introduction.

*(MagLab contact: Ryan Rodgers, ICR)*

## **Zeiss Micro Imaging, Thornwood, NY**

The Optical Microscopy group at the MagLab is negotiating a contract with Zeiss on the development of an educational and technical support microscopy website, including the latest innovations in digital imaging technology. As part of the collaboration, microscopists are field-testing new Zeiss equipment and developing new methods of fluorescence microscopy.

*(MagLab contact: Eric Clark, Optical Microscopy)*

## **National or International Labs/Institutes**

### **3D Bioreactor, Karlsruhe Institute of Technology, Germany**

NHMFL is collaborating with the Karlsruhe Institute of Technology, Germany, in designing and testing the 3D bioreactor for functional interaction with the variety of cells.

*(MagLab contact: Victor Schepkin, MR imaging)*

### **CERN, Geneva, Switzerland**

The Large Hadron Collider (LHC) at CERN uses a 27 km ring of superconducting magnets based on Nb-Ti to accelerate particles in the world's largest and most powerful collider but plans to increase the energy capability of LHC will require higher magnetic fields. The Applied Superconductivity Center is collaborating with CERN to characterize and optimize a new generation of accelerator quality Nb<sub>3</sub>Sn strands based on the powder-in-tube process that have the potential to provide the performance necessary for the next step in LHC upgrades.

*(MagLab contacts: David Larbalestier, Chiara Tarantini, and Peter Lee, ASC)*

### **Dana-Farber Cancer Institute, Boston, MA**

Current collaboration between Dana-Farber Cancer Institute and the MagLab is aimed at determining the molecular details of HIV envelope protein gp41 using electron paramagnetic resonance methods. Other goals include characterization of antibody-induced structural changes of gp41, and developing optimized vaccine immunogens by structural approaches.

*(MagLab contact: Likai Song, EMR)*

### **EUCARD2 (European Collaboration for Accelerator R&D)**

EUCARD2 is a European Framework collaboration of about 10 European Labs aimed at developing kiloamp high temperature superconductor cables for future application to a high energy LHC. The European emphasis is on Roebel cables of REBCO coated conductors, but an equally attractive cable for accelerator purposes is a round wire cable made in the Rutherford style out of Bi-2212 (Bi<sub>2</sub>Sr<sub>2</sub>CaCu<sub>2</sub>O<sub>8-x</sub>). This conductor has been developed at the MagLab under DOE-HEP support in the context of the Bismuth Strand and Cable Collaboration (BSCCo) that unites the MagLab, BNL, FNAL, LBNL, and OST in a team developing this material for accelerator use. The MagLab is now the US point of contact for collaborations between EUCARD2 and the US program.

*(MagLab contacts: David Larbalestier, Eric Hellstrom, and Jianyi Jiang, ASC)*

### **European MicroKelvin Platform (EMP)**

The University of Florida MicroKelvin Laboratory and the National High Magnetic Field Laboratory's High B/T Facility has entered into a co-operative agreement with the European Microkelvin Platform (EMP) to establish a program of collaborative research in areas of mutual interest at ultra-low temperatures, with a focus on promoting and facilitating, where feasible, exchange visits for scientists and students. The EMP is a consortium of 20 leading ultra-low temperature physics and technology partners in Europe. The main aim of the consortium is the further integration of ultra-low temperature research for the development of new ideas, knowledge, technology, applications and commercial exploitation to enhance further the innovation potential in this field. In addition, to research activities, the parties to this agreement will cooperate in the training of ultra-low temperature physicists through course offerings to qualified candidates such as the European Advanced Cryogenics Course and the Cryogenics Course at the University of Florida.

*(MagLab contact: Neil Sullivan, UF)*

### **Fermilab, Batavia, IL**

The shaping of Nb sheet to produce superconducting RF cavities introduces microstructural defects that may impact cavity performance; in collaboration with Fermilab, the Applied Superconductivity Center is studying the surface and bulk superconductivity in deformed niobium wires. Controlled deformation is introduced into the Nb samples wire drawing and the

# Chapter 2 – Laboratory Management

resulting defects are quantified and compared to the measured superconducting properties.

*(MagLab contact: Peter J. Lee, ASC)*

## **Fermilab, Batavia, IL**

The LHC Accelerator R&D Program (LARP) in the United States is developing the prototype magnets for the High-Luminosity LHC Accelerator Upgrade Project (HL-LHC AUP) at The European Organization for Nuclear Research (CERN). In this collaboration funded by the Fermi National Accelerator Laboratory (FNAL) who manages the conductor program for LARP, we developed a new method for measuring Nb<sub>3</sub>Sn wire with high critical current. Then, as a verification of the results from the wire manufacturer, we will measure Nb<sub>3</sub>Sn wire critical current and residual resistance ratio tests for a total of 112 wire samples.

*(MagLab contact: Jun Lu, MS&T)*

## **Future Fuels Institute, FL**

The Future Fuels Institute (FFI) was established to enhance the existing Ion Cyclotron Resonance (ICR) Program at the NHMFL to deal specifically with biological and fossil fuels, particularly for heavy oils and synthetic crudes. Supported by sponsoring companies and collaborative entities (instrument companies, universities, and research institutes), the FFI works to develop and advance novel techniques for research applications and problem solving. FFI is actively seeking up to 6 industrial collaborators as corporate members to support core research programs. Each of these corporate members will be asked to provide \$250,000/year for 4 years. The member may terminate the membership by giving the institute 30 days written notice prior to the membership renewal date. Current corporate members include:

- Total
- Petrobras
- Reliance Industries
- Ecopetrol

The institute also serves as a training center for fuel-related science and technology.

*(MagLab contact/Director: Ryan Rodgers)*

## **Helmholtz Zentrum Berlin, Berlin, Germany**

The MagLab has partnered with the Helmholtz Zentrum Berlin (HZB) to develop the highest field magnet worldwide for neutron scattering at HZB. In March 2007, HZB (formerly the Hahn-Meitner Institute) signed

an agreement with Florida State University Magnet Research and Development Inc. in 2007. The magnet exceeded specification in October 2014 and has been serving users at 25T since July 2015. The original design and construction agreement has ended, we now have an agreement to assist with operation and maintenance.

*(MagLab contact: Mark D. Bird, MS&T)*

## **Institute of Vertebrate Paleontology and Paleoanthropology (IVPP) of Chinese Academy of Sciences**

The collaboration between the IVPP and the MagLab is related to the investigation of Late Cenozoic Vertebrate Paleontology and Paleoenvironments of the Tibetan Plateau (China). Samples collected in this project are analyzed in the Geochemistry Laboratories in the MagLab.

*(MagLab contact: Yang Wang, Geochemistry Program)*

## **International Thermonuclear Experimental Reactor (ITER), Cadarache, France US-ITER Project Office, Oak Ridge, TN; University of Twente, Enschede, the Netherlands**

The Applied Superconductivity Center has for the last 5 years played a major role in helping ITER-IO understand the properties of the cables being wound into the Central Solenoid (CS) and the Tokamak Field (TF) coils. A central task has been the disassembly and metallographic analysis of the prototype Cable-in-Conduit-Conductors (CICCs) needed for TF and CS coils after testing in the SULTAN facility in conditions designed to simulate ITER operations. Many of these conductors Toroidal Field (ITER Organization) and Central Solenoid (US-ITER) CICCs typically suffered significant performance degradation during cyclic loading and occasional warm-up and cool-down cycles. The tests performed at the MagLab were able to identify many of the causes for this degradation and were instrumental in developing new cable patterns that resolved the degradation. This work was collaborative with groups at CEA-Cadarache, the University of Twente in the Netherlands, and US-ITER.

*(MagLab contacts: Peter J. Lee and David C. Larbalestier, ASC)*



# Chapter 2 – Laboratory Management

## ***International Thermonuclear Experimental Reactor (ITER), US-ITER Project Office, Oak Ridge National Laboratory (ORNL), Oak Ridge, TN***

The United States is part of an exciting international collaboration to demonstrate the feasibility of an experimental fusion reactor that is under construction in France. The MS&T's Mechanical Properties Lab is the US-ITER primary materials research and qualification Laboratory supporting the US effort. The Tokamak machine consists of three types of very large, complex superconducting magnets that all utilize Cable-in-Conduit Conductors (CICC) as the main structural components. Another important component for stress management of the Central Solenoid is a massive CS pre-compression structure (Tie Plates). The conduit and tie plate alloys, and their welds, are being studied and characterized here to ensure their performance and reliability. The funding for this research is provided by US-DOE, US-ITER Project Office at ORNL.

*(MagLab contact: Bob Walsh, MS&T)*

## ***International Thermonuclear Experimental Reactor (ITER), US-ITER Project Office, Oak Ridge National Laboratory (ORNL), Oak Ridge, TN***

The United States is responsible for winding and heat treatment of ITER central solenoid (CS) coils. Total of 7 CS modules will be manufactured by General Atomic in California. In order to ensure the quality of the heat treatment of these 7 modules, a number of Nb<sub>3</sub>Sn wire samples are placed together with the coil during heat treatment as witnesses. The MS&T's Physical Properties Testing Lab is the US-ITER primary testing Lab for Nb<sub>3</sub>Sn wires. A total of over 100 Nb<sub>3</sub>Sn heat treatment witness samples will be tested at 4.2 K in 11 – 13T magnetic field. The funding for this research is provided by US-DOE, US-ITER Project Office at ORNL. *(MagLab contact: Jun Lu, MS&T)*

## ***Jefferson Lab, Newport News, VA***

Recently, Nitrogen and Titanium doping have emerged as highly effective methods of improving the quality factor on Nb SRF cavities; the Applied Superconductivity Center is working with scientists at Jefferson Lab to evaluate the interaction between prior cold-work and doping treatment of Nb samples and their influence on the superconducting properties. Doping is carried out at Jefferson Lab and superconducting property measurements, including magneto optical imaging area carried out at the MagLab.

*(MagLab contact: Peter J. Lee, ASC)*

## ***Key Laboratory of Electromagnetic Processing of Materials, Northeastern University, Shenyang, China***

The collaboration between the Northeastern University and the MagLab is related to the magnetic field impact on fabrication of high strength conductors. Two graduate students from Northeastern University are studying in the MagLab and a MagLab faculty member visited Northeastern University in 2017. They published two joint papers in 2017.

*(MagLab contact: Ke Han, MS&T)*

## ***Large Accelerator Project for the HiLumi upgrade of the CERN LHC, Brookhaven National Lab, Upton, NY***

Accelerator magnets based on Nb<sub>3</sub>Sn wires are required to provide the increased magnetic fields for the next LHC upgrade. The Applied Superconductivity Center is collaborating with Brookhaven National Lab to understand the design and heat treatment optimization of accelerator magnet quality strand fabricated by the internal Sn process with a view to driving high current density strands to smaller filament sizes. Close collaboration with the R&D billets being manufactured for LARP under the Conductor Development Program of DOE High Energy Physics is a key part of the work.

*(MagLab contacts: Chiara Tarantini, Peter J. Lee, and David C Larbalestier, ASC)*

## ***Lawrence Berkeley Laboratory, Accelerator and Fusion Research, Berkeley, CA***

The Applied Superconductivity Center and the Magnet Science and Technology division of the MagLab are collaborating with researchers at the Berkeley National Laboratory on the testing of Roebel-style cables based on REBCO coated conductors, a high temperature superconductor. Testing of a 10-strand cable with transposed 2 mm wide strands is in preparation. Roebel-style cables represent one of three viable concepts for REBCO coated conductor cables suitable for high field magnets.

*(MagLab contact: Huub Weijers, MS&T)*

## ***Los Alamos National Laboratory Community Programs Office, NM***

CIRL works closely with our counterpart, the Los Alamos National Laboratory Community Programs Office. Over the last year we have developed a partnership wherein we share information and resources on our educational activities. The community programs office has a large staff that oversees more than 15 different educational /

# Chapter 2 – Laboratory Management

community outreach programs including the Bradbury Museum. (*MagLab contact: Roxanne Hughes, Carlos Villa, Educational Programs*)

## **School of Mechanical Engineering and Automation, Fuzhou University, Fuzhou, China**

The collaboration between the Fuzhou University and the MagLab is related to the characterization of high strength conductors.

(*MagLab contact: Ke Han, MS&T*)

## **Scripps Research Institute, FL**

We continue to collaborate with Dr. Thomas Kodadek (Scripps Florida), for structural characterization of transfer RNA synthetases functioning in roles other than protein synthesis. Those functions result from complexation of a given synthetase with one or more other proteins. Synthetase mutations lead to various diseases. Scripps provides the mutants, and we use hydrogen/deuterium exchange monitored by FT-ICR mass spectrometry to map the protein:protein contact surfaces in the complexes to establish structure function relationships.

(*MagLab contact: Alan Marshall, ICR*)

## **Southeast Center for Integrated Metabolomics, University of Florida, FL**

With a new \$9 million grant from National Institutes for Health, the University of Florida created a Southeast Center for Integrated Metabolomics which joins a consortium of five other regional resource centers and a national coordinating center to spur metabolomics research in the United States by funding training, technology development, standards synthesis and data-sharing initiatives. Metabolomics draws from many scientific disciplines, including chemistry, physiology, statistics, genetics, computer science and systems design and, as such, has many partners: the National High Magnetic Field Laboratory at Florida State University, Sanford-Burnham Medical Research Institute, Ohio State University, the University of Georgia, Imperial College London, the University of Geneva and industry partners IROA Technologies and Thermo Fisher Scientific.

(*MagLab contact: Matt Merritt, AMRIS*)

## **Thomas Jefferson National Accelerator Facility, Newport News, VA**

Large-grain Nb has become a viable alternative to fine-grain Nb for the fabrication of superconducting radio-

frequency cavities. NHMFL collaborated with engineers at Jefferson Lab to evaluate the effect of thermal processing and grain size on the mechanical properties of Nb. The mechanical properties evaluation was carried out at MS&T's Mechanical Properties Lab.

(*MagLab contact: Bob Walsh, MS&T*)

## **Woods Hole Oceanographic Institute, FL**

As part of FSU's Gulf Research Initiative Consortium, NHMFL collaborates with Christopher Reddy and Robert Nelson at WHOI in characterization of petroleum oil spills at the molecular level, by gas chromatography x gas chromatography and FT-ICR mass analysis. Characterization of the 2010 Macondo wellhead oil has been completed, and current research focuses on subsequent physical, chemical, and biological changes as the spill propagates into the environment.

(*MagLab contact: Ryan Rodgers, ICR*)

## **Universities**

### **Florida State University, College of Education, Tallahassee, FL**

The Center for Integrating Research & Learning works closely with faculty from the FSU College of Education to network and strengthen programs on campus and at the Lab. Currently, we utilize the expertise of FSU faculty for research projects. We also recruit graduate students from FSU departments to conduct research on CIRL programs.

(*MagLab contact: Roxanne Hughes, Educational Programs*)

### **Michigan State University, Lansing, MI**

The Applied Superconductivity Center is collaborating with Michigan State University on a US-DOE funded project to study the impact of grain boundaries and associated microstructural defects on the performance of superconducting cavities using the advanced microstructural, microchemical, and electromagnetic characterization techniques and expertise available in the MagLab.

(*MagLab contact: Peter J. Lee, ASC*)

### **Nagoya University, Nagoya, Japan; Karlsruhe Institute of Technology (KIT), Karlsruhe, Germany; Leibniz Institute for Solid State and Materials Research (IFW), Dresden, Germany**

The Applied Superconductivity Center is collaborating

# Chapter 2 – Laboratory Management

with Nagoya University, the Karlsruhe Institute of Technology, and the Leibniz Institute in the investigation of iron-based superconductors in order to establish their intrinsic properties and determine their potential for applications using electromagnetic characterization techniques with the high-fields and expertise available at the MagLab.

*(MagLab contact: Chiara Tarantini, ASC)*

## **Osaka City University, Japan**

The EMR group received joint funding with the University of Modena in Italy and Osaka City University in Japan through an International Program sponsored by the Air Force's Asian Office of Aerospace Research and Development (AOARD). This joint program focuses on quantum properties of molecular magnets. A cooperative agreement between Osaka City University and Florida State University has been established in order to formalize this collaboration.

*(MagLab contact: Stephen Hill, EMR)*

## **The Pennsylvania State University, State College, PA**

Scientists from the NMR User Program at the MagLab are working with Prof. Jeffrey Schiano in the PSU Dept. of Electrical Engineering to improve field regulation in powered magnets to enable high resolution NMR measurements at previously inaccessible fields.

*(MagLab contact: William Brey, NMR)*

## **Radboud University, Nijmegen, The Netherlands**

The MagLab has partnered with the High Magnetic Field Lab in The Netherlands to develop a 45T hybrid magnet using only 24 MW of power. The project was funded by the Dutch government in 2006, and in 2012 an agreement was signed for the MagLab to play a leading role in the development of the Nb<sub>3</sub>Sn cable-in-conduit superconducting coil for this magnet system. This will be the 4th hybrid outsert to be developed at the MagLab (MagLab 45T, HZB, FSU SCH, Nijmegen) and the Dutch Lab will benefit from our extensive experience. When complete it is expected to be one of the two 45T systems worldwide. Fabrication of the superconducting coil has been finished and assembly of the cold-mass nears completion. The completed cold-mass is expected to be transported to Radboud University in the first quarter of 2018.

*(MagLab contact: Iain Dixon, MS&T)*

## **Shanghai University, Shanghai, China**

The collaboration between the Shanghai University and the MagLab is related to the solidification of metallic materials. A scientist from Shanghai University was in the MagLab as a visiting scientist for two months to do the research on microstructure of high-strength materials. They have published two joint papers.

*(MagLab contact: Ke Han, MS&T)*

## **St. Andrews University, UK**

The EMR group has an ongoing partnership with St. Andrews University in the UK, involving the development of a high-power (1 kW), high-frequency (94 GHz) pulsed EPR spectrometer (HiPER) for its User Program.

*(MagLab contact: Stephen Hill, EMR)*

## **Texas A&M University, College Station, TX**

Texas A&M University is fabricating Nb sheets and tubes with ultra-fine grain size and controlled textures for superconducting RF cavities by using the Equal Channel Angular Extrusion (ECAE) process; the Applied Superconductivity Center is providing microstructural characterization of the Nb primarily using the new fast-camera crystallographic orientation mapping system at the MagLab.

*(MagLab contact: Peter J. Lee, ASC)*

## **University of Colorado Boulder, Boulder, CO**

Nb<sub>3</sub>Sn is the primary superconductor for providing magnetic fields in the 11-22 T range but is brittle and there is the potential for filament fracture when subjected to the high Lorentz forces produced when the superconducting magnets are energized. The University of Colorado Boulder (using the NIST-Boulder electromechanical testing facilities) has determined the strain sensitivity of a wide range of commercial Nb<sub>3</sub>Sn wires and has found a large variation in irreversibility strains (the limit in strain that the wire can be subjected to before unrecoverable degradation in performance), and the Applied Superconductivity Center has been working with UC-Boulder to try and understand the reasons for these variations so that future strands will be able to withstand the forces generated at high magnetic fields.

*(MagLab contact: Peter J. Lee, ASC)*

## **University of Illinois, Chicago, IL**

The National High Magnetic Field Laboratory, Advanced Magnetic Resonance Imaging and Spectroscopy (AMRIS)

# Chapter 2 – Laboratory Management

Facility in the McKnight Brain Institute of the University of Florida is collaborating with the research group of Professor Richard Magin in the Department of Bioengineering of the University of Illinois, Chicago to measure anomalous translational diffusion in porous materials. These measurements provide unique information about the microstructure of porous materials and require the high sensitivity of, and high strength gradients systems available on, the 17.6T magnetic system in the AMRIS Facility.

*(MagLab contact: Thomas H. Mareci, AMRIS Facility)*

## **University of Illinois, Chicago, IL**

The National High Magnetic Field Laboratory, Advanced Magnetic Resonance Imaging and Spectroscopy (AMRIS) Facility in the McKnight Brain Institute of the University of Florida is collaborating with the research group of Professor Dieter Klatt in the Department of Bioengineering of the University of Illinois, Chicago to measure properties of elastic materials using magnetic resonance imaging. These measurements provide unique, detailed information about the propagation of motion through elastic materials and require the high sensitivity available on the 11.1T magnetic system in the AMRIS Facility.

*(MagLab contact: Thomas H. Mareci, AMRIS Facility)*

## **University of Modena, Italy**

The EMR group received joint funding with the University of Modena in Italy and Osaka City University in Japan through an International Program sponsored by the Air Force's Asian Office of Aerospace Research and Development (AOARD). This joint program focuses on quantum properties of molecular magnets.

*(MagLab contact: Stephen Hill, EMR)*

## **University of Texas Medical Branch at Galveston**

The ICR Program collaborates with Profs. Carol L. Nilsson and Mark R. Emmett. One current project is proteomics and glycomics of brain cancer-derived stem-like cells correlated to gene expression data and patient outcomes. A second project involves FT-ICR mapping of lipid alterations in spinal cord injury.

*(MagLab contact: Alan Marshall, ICR)*

## **Community Groups/ Educational Groups**

### **Alachua County Public Schools, Gainesville, FL**

The UF-NHMFL site has a close working relationship with the Alachua County Public Schools through our in-classroom presentations, participation in evening

programs and special events, and bi-monthly science club. *(MagLab contact: Elizabeth Webb, UF)*

### **CAISE - Center for the Advancement of Informal Science Education, D.C.**

The Center for the Advancement of Informal Science Education (CAISE) works in collaboration with the National Science Foundation (NSF) Advancing Informal STEM Learning (AISL) Program to strengthen and advance the field of professional informal science education and its infrastructure by providing resources for practitioners, researchers, evaluators, and STEM-based professionals. CAISE also facilitates conversation, connection, and collaboration across the ISE field — including in media (TV, radio, and film); science centers and museums; zoos and aquariums; botanical gardens and nature centers; cyberlearning and gaming; and youth, community, and out of school time programs. The Center for Integrating Research & Learning (CIRL) has worked with CAISE to provide advice for reaching Principal Investigators and improving the evaluation of broader impacts.

*(MagLab contact: Roxanne Hughes, Educational Programs)*

### **Community Classroom Consortium, Tallahassee, FL**

The Community Classroom Consortium (CCC) is a coalition of more than thirty cultural, scientific, natural history, and civic organizations in North Florida and South Georgia that provide educational experiences and resources to the public, especially K-12 teachers and students. Representatives from CIRL and Public Affairs represent the Lab on the board of this organization and as general members.

*(MagLab contact: Kari Roberts, Educational Programs)*

### **Florida Afterschool Network, Tallahassee, FL**

The Florida Afterschool Network (FAN) is an organization that is working toward creating and sustaining a statewide infrastructure to establish collaborative public and private partnerships that connect local, state, and national resources supporting afterschool programs that are school-based or school-linked; develop quality afterschool standards that are endorsed and promoted by statewide stakeholders and through Florida Afterschool Network; and promote public awareness and advocate for policy that expands funding, quality improvement initiatives, and accessibility of afterschool programs. The Center for

# Chapter 2 – Laboratory Management

Integrating Research & Learning is a member of the advisory council for this organization.

*(MagLab contact: Carlos Villa, Educational Programs)*

## **Future Physicists of Florida**

Future Physicists of Florida is an organization dedicated to recognizing talented middle school math and science students and providing educational guidance to these students to prepare them for careers in physics and engineering. CIRL is a partner in the organization.

*(MagLab contact: Carlos Villa, Educational Programs)*

## **Leon County and City of Tallahassee Commission on the Status of Women and Girls, FL**

The Commission on the Status of Women and Girls was formed in April of 2011 by the Leon County Board of County Commissioners. The CSWG was established as a citizens advisory committee. In March of 2013, the City of Tallahassee proudly joined Leon County and created the new Tallahassee/Leon County Commission on the Status of Women and Girls (CSWG). By establishing and supporting this Commission, the City of Tallahassee and Leon County have taken a strong stand in support of women and girls in our community. Roxanne Hughes serves as in an advisory capacity for this organization to comment on programs and policies that affect girls and women in STEM.

*(MagLab contact: Roxanne Hughes, Educational Programs)*

## **Leon County Schools, FL**

CIRL works closely with Leon County Schools (LCS) through our K-12 outreach and our middle school mentorship program. CIRL staff worked with Title I elementary school teachers from LCS to develop and facilitate a year-long teacher professional development that culminated in a STEM challenge for students.

*(MagLab contact: Carlos Villa, Educational Programs)*

## **Los Angeles County Museum of Natural History, CA**

The collaboration between the IVPP and the MagLab is related to the investigation of Late Cenozoic Vertebrate Paleontology and Paleoenvironments of the Tibetan Plateau (China). Stable isotopic compositions of the samples collected in this project are analyzed in the Geochemistry Laboratories in the MagLab.

*(MagLab contact: Yang Wang, Geochemistry Program)*

## **Oasis Center for Women and Girls, FL**

and the Center partner to provide summer physics

The Oasis Center is a nonprofit organization in Tallahassee whose mission is to "improve the lives of women and girls through celebration and support." They are focused on personal, professional, and economic concerns facing women, girls, and their families. CIRL has worked closely with this center through outreach including providing mentors and/or tours for their science summer camps.

*(MagLab contact: Roxanne Hughes, Educational Programs)*

## **Palmer Munroe Teen Center, FL**

The Palmer Munroe Teen Center is a community center that focuses on teens from low income neighborhoods in Tallahassee. The center is run by the City of Tallahassee. CIRL works closely with students and staff at the center through outreach.

*(MagLab contact: Roxanne Hughes, Educational Programs)*

## **Panhandle Area Educational Consortium (PAEC), FL**

The Panhandle Area Educational Consortium serves 13 school districts in the panhandle of Florida. PAEC provides leadership and support services to these districts, increases networking among members, and maximizes resources. Over the years, CIRL has provided teacher workshops and high school summer information sessions to students and teachers from these districts with PAEC's facilitation.

*(MagLab contact: Roxanne Hughes, Educational Programs)*

## **South Florida Water Management District (SFWMD)**

The collaboration between the SFWMD and the MagLab is related to the investigation of land-use and change on food web structure and mercury cycling in the Everglades. Isotopic compositions of the samples collected in this project were analyzed in the Geochemistry Laboratories in the MagLab.

*(MagLab contact: Yang Wang, Geochemistry Program)*

## **WFSU-TV, Tallahassee, FL**

The Center for Integrating Research & Learning partners with WFSU-TV, the area's public television station, to administer SciGirls. The program is a 2-week camp for middle and high school girls with an interest in science. The collaboration between the MagLab and WFSU-TV has resulted in a successful 6-year camp that has engaged the larger community. In addition, WFSU-TV

# Chapter 2 – Laboratory Management

experiences for students entering high school.  
(MagLab contact: Roxanne Hughes, Educational Programs)

## **Spin Offs**

### **MAXIKAT, Inc., FL**

Maxikat is a spinoff company that performs data analysis for petroleum industry. It was formed in 2015.  
(MagLab contact: Vladislav Lobodin)

### **Omics LLC, FL**

Omics LLC is a spinoff company that serves the data analysis and interpretation needs of the high resolution mass spectrometry market. It was formed 8 years ago and has grown over the years to address a wider analytical community.  
(MagLab contact: Ryan Rodgers)

### **Specialized Crystal Processing, Inc., FL**

Specialized Crystal Processing, Inc. (SCPI) is an advanced materials processing, manufacturing and consultation spin-off of the National High Magnetic Field Laboratory. The SCPI home base facility is located off-campus in Tallahassee, FL and has the infrastructure for both R&D and manufacturing of highly specialized single crystal products. These crystals can be used for a variety of applications, including but not limited to high tech devices and sensors, advanced materials basic science research and crystalline additives for composite materials.  
(MagLab contact: Jeffrey Whalen, Theo Siegrist)

# Chapter 2 – Laboratory Management

## 2.10. Data Management Plan

The National High Magnetic Field Laboratory (MagLab) provides seven high magnetic field user facilities across the three campuses of the MagLab at Florida State University, the University of Florida, and Los Alamos National Laboratory. These user facilities are the DC Field Facility; Pulsed Field Facility; High B/T Facility; and the Nuclear Magnetic Resonance (NMR), Electron Magnetic Resonance (EMR), Ion Cyclotron Resonance (ICR), and Advanced Magnetic Resonance Imaging and Spectroscopy (AMRIS) Facilities. Each user facility is built around unique magnetic field facilities and world leading scientific expertise serving a multi- and interdisciplinary scientific research community. Though each facility has a unique environment and tradition of data management, this policy is applied in a consistent way across sites. Our data management practices are driven by our user community and the standards of the associated funding agencies. The policy is reviewed annually to stay current with user demands and changes in technology.

### Data Types

Our user facilities data consists primarily of electronic records of measurements taken during a scheduled experiment. Data from a facility can be generated on either a facility computer system, visiting user's computer, or special data acquisition systems provided by a user. These electronic records may or may not exist on a facility computer during the course of an experiment.

The MagLab scientific staff develops, maintains, and updates many software routines for analysis of data tailored to the different needs of the user facilities.

### Data Standards

The standards for data vary across user facilities as required by the experimental methods and equipment used. The most open standard for the DC Magnet facility is for ASCII text files in column format. High data rate experiments such as the Pulsed Field Facility necessitate the use of open binary formats or custom file formats developed by MagLab personnel. The ICR facility also stores data in a MagLab-developed format. For NMR experiments, data formats are dictated by the research equipment used, such as the vendor-specific format for NMR data collected by Bruker spectrometers. Magnetic Resonance Imaging data from

our AMRIS facility is in DICOM images for OSIRIX viewer. Data is made available to researchers through the use of the current picture archiving and communication systems (PACS) with dedicated computers on a local high speed network.

All MagLab-developed formats are open. Specifications and software to read and analyze data in these formats is available to the scientific community for free or at nominal reproduction costs. These software tools are provided on Laboratory web sites and software storage areas.

Meta-data can be recorded with the raw data files at the option of the researchers. Other meta-data is recorded in the users written notebooks, computer files, or other media at the option of the principal investigator. Management of the meta-data associated with standard data files is exclusively the purview of the principal investigator.

### Data Access Policies

The principal investigator in charge of a user experiment has exclusive rights to all data related to that experiment, including raw data and meta-data. Access to experiment data is granted only to individuals designated by the principal investigator. The principal investigator retains full control of the use of the data, including its publication in refereed literature. The principal investigator is responsible for adhering to the policies and procedures of their funding agency.

The MagLab's data management and sharing practices align with the policy applied to NSF and NIH single investigator grants, as the MagLab user community consists primarily of researchers supported by these types of awards.

### Data Re-use Policies

Data is not reused nor are any data-mining operations performed by the MagLab on historical user data. Once data is collected and provided to the user, it is solely the property of that particular user. Any reuse within their own program (external to MagLab) is strictly at their discretion. Users are encouraged to make their research findings and final data readily available for research purposes to qualified individuals within the scientific community by publishing the results in peer-reviewed journals and by presenting the findings at conferences. In addition, the MagLab requires all users to submit a one-page annual research

# Chapter 2 – Laboratory Management

report on each project for inclusion in the MagLab Annual Report. These reports are available on the MagLab web site and serve to illustrate the quantity, quality, and breadth of research activities at the Lab. Each year, a subset of these reports are chosen as highlights to be published in a Special Issue of MagLab Reports, the MagLab's quarterly magazine that is widely distributed to scientists, students, and granting agencies.

Users are reminded to follow all regulations of the NSF and NIH data sharing policies by posting of this policy

([http://grants.nih.gov/grants/policy/data\\_sharing](http://grants.nih.gov/grants/policy/data_sharing)) on the AMRIS webpage (<http://amris.mbi.ufl.edu>) as well as via periodic emails to the user group. (see NIH Grants Policy Statement:

<http://grants.nih.gov/policy/nihgps/index.htm> and NSF Award and Administration Guide (<https://www.nsf.gov/bfa/dias/policy/>).

When appropriate, users are encouraged to deposit standard data formats in existing repositories, such as the

“Protein Data Bank” and “Biological Magnetic Resonance Data Bank.”

## Data Archiving

Data collected and stored on a MagLab facility computer system are backed-up to local hard drives, tape storage, or other common backup media. Data archiving is primarily the responsibility of the PI at their home institutions, but archived user data are retained at the MagLab facility for a period ranging from six months to two years after collection at the MagLab. This retention policy is reviewed annually and may be revised at the request of our user community, or in response to the continually evolving capabilities and reduction in costs of data storage. Archived data will only be made available to individuals at the request of the principal investigator of the project.

Users may transfer their data to portable storage devices or other computers, both local and remote, in accordance with local facility administration policies. Upon request, user data will be archived on optical or other similarly permanent media and provided to the user.





## Chapter 3 – User Facilities

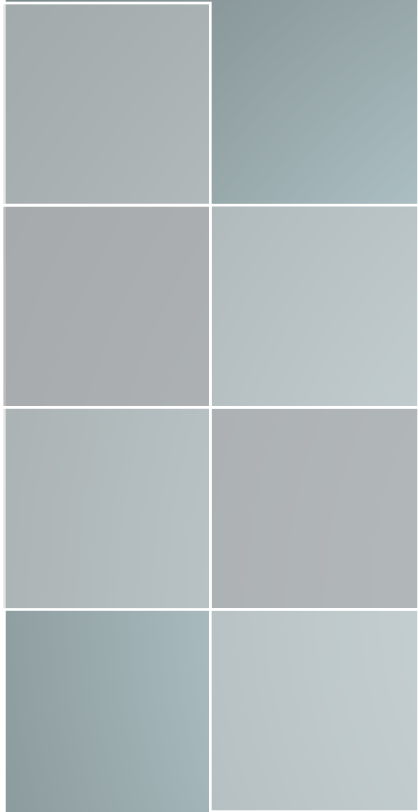

# Chapter 3 – User Facilities

## 3.1. User Program

The MagLab is one user program with seven user facilities. DC Field, Pulsed Field, High B/T, NMR-MRI@FSU, NMR-MRI@UF (AMRIS), EMR, and ICR, each with exceptional instrumentation and highly qualified staff scientists and staff, comprise the MagLab’s User Program. In this chapter of the annual report, information is presented about the proposal review process, user safety training, special user funding opportunities, and user committee report.

### 3.1.1. Proposal Review Process

Across all seven facilities, proposals for magnet time are submitted online: (<https://nationalmaglab.org/user-resources/request-magnet-time>) and reviewed in accordance with the NHMFL User Proposal Policy ([https://nationalmaglab.org/images/user\\_resources/seachable\\_docs/request\\_magnet\\_time/user\\_proposal\\_policy.pdf](https://nationalmaglab.org/images/user_resources/seachable_docs/request_magnet_time/user_proposal_policy.pdf)). In brief, each user facility has a User Proposal Review Committee (UPRC) comprised of at least seven members, with more external members than internal. UPRC memberships are treated confidentially by the laboratory but are available for review by NSF and NHMFL advisory committees. Proposal reviews are conducted in strict confidence and are based on two criteria: (1) the scientific and/or technological merit of the proposed research, and (2) the “broader impacts” of the proposed work. They are graded online according to a scale, ranging from “A” - Proposal is high quality and magnet time must be given a high priority; to “C” -

Proposal is acceptable and magnet time should be granted at NHMFL discretion; to “F” – Proposal has little/no merit and magnet time should not be granted. The Facility Directors dovetail the UPRC recommendations with availability and scheduling of specific magnets, experimental instrumentation, and user support scientists and make recommendations for magnet time assignments to the NHMFL Director. The NHMFL Director is responsible for final decisions on scheduling of magnet time based on these recommendations.

### 3.1.2. Research Reports

At the end of each year, MagLab users and faculty at FSU, UF, and LANL submit brief abstracts of their experiments, research, and scholarly endeavors. Users generated 425 research reports in 2017 (**Table 1**). All reports will be released in summer 2018.

**Table 1: 2017 Research Reports by Facility**

FACILITIES	Number of Reports
AMRIS Facility at UF	52
DC Field Facility	124
EMR Facility	47
High B/T Facility at UF	7
ICR Facility	30
NMR Facility	55
Pulsed Field Facility at LANL	69
<b>MAGLAB DEPARTMENTS &amp; RELATED GROUPS</b>	
Applied Superconductivity Center	18
Condensed Matter Theory/ Experiment (FSU)	10
Magnet Science & Technology	9
UF Physics	4
<b>TOTAL REPORTS</b>	<b>425</b>

# Chapter 3 – User Facilities

## 3.2. User Collaboration Grants Program (UCGP) and Other Additional Funding Opportunities

### 3.2.1. UCGP

The National Science Foundation charged the National High Magnetic Field Laboratory with developing an internal grants program that utilizes the NHMFL facilities to carry out high quality research at the forefront of science and engineering and advances the facilities and their scientific and technical capabilities. The User Collaboration Grants Program (UCGP), established in 1996, stimulates magnet and facility development and provides intellectual leadership for research in magnetic materials and phenomena.

The UCGP seeks to achieve these objectives by funding research projects of normally one- to two-year duration in the following categories:

- small, seeded collaborations between internal and/or external investigators that utilize their complementary expertise;
- bold but risky efforts that hold significant potential to extend the range and type of experiments; and
- Initial seed support for new faculty and research staff, targeted to magnet laboratory enhancements.

The Program strongly encourages collaboration between NHMFL scientists and external users of NHMFL facilities. Projects are also encouraged to drive new or

unique research, i.e., serve as seed money to develop initial data leading to external funding of a larger program. In accordance with NSF policies, the NHMFL cannot fund clinical studies.

Twenty (20) UCGP solicitations have now been completed with a total of 551 pre-proposals being submitted for review. Of the 538 proposals, 288 were selected to advance to the second phase of review, and 126 were funded (23% of the total number of submitted proposals).

### 2017 Solicitation and Awards

The NHMFL UCGP has been highly successful as a mechanism for supporting outstanding projects in the various areas of research pursued at the Laboratory. The proposal submission and two-stage proposal review process has been handled by means of a web-based system. The most recent solicitation, announced in March 2017, is complete, and its awards will be issued approximately in April 2018.

Of the 13 pre-proposals received, the committee recommended that 9 pre-proposals be moved to the full proposal state. Of the 9 full proposals, 4 were awarded. A breakdown of the review results is presented in **Tables 1 and 2**.

**Table 1:** UCGP Proposal Solicitation Results – 2017

Research Area	Pre-Proposals Submitted	Pre-Proposals Proceeding to Full Proposal	Project Funded
Condensed Matter Science	6	5	2
Biological & Chemical Sciences	6	3	1
Magnet & Magnet Materials Technology	1	1	1
<b>Total</b>	<b>13</b>	<b>9</b>	<b>4</b>

**Table 2:** UCGP Funded Projects from 2017 Solicitation.

Principal Investigator	NHMFL Institution	Project Title	Funding
Lissa Anderson	NHMFL	Precision Proteoform Measurement Empowers the 21 T FT-ICR Satellite Center of the National Resource for Translational and Developmental Proteomics	\$199,996
Chao Huan	NHMFL	NMR Studies of Novel Phases of 3He in Extreme Conditions: Nanoconfinement, Ultra-low Temperatures and High Magnetic Fields	\$179,075
Marcelo Jaime	LANL	Revealing hidden anisotropies in quantum matter via thermal properties under strain	\$200,000
Jun Lu	NHMFL	Superconducting transformer for superconducting cable research and development	\$199,863

# Chapter 3 – User Facilities

## 2018 Solicitation

The 2018 Solicitation announcements should be released around March, 2018. Awards will be announced by the end of the year, and, depending upon the core grant renewal, made in early 2018.

## Results Reporting

To assess the success of the UCGP, reports were requested in January 2017 on grants issued from the solicitations held in the years 2010 through 2017, which had start dates, respectively, near the beginnings of years 2011 through 2017. At the time of the reporting, some of these grants were in progress, and some had been completed. For this “retrospective” reporting, PIs were asked to include external grants, NHMFL facilities enhancements, and publications that were generated by the UCGP. Since UCGP grants are intended to seed new research through high risk initial study or facility enhancements, principal investigators (PIs) were

allowed and encouraged to report results that their UCGP grant had made possible, even if these were obtained after the term of the UCGP grant was complete.

The PIs reported:

- Lab enhancements which were used by 122 different external user groups.
- At least partial support for 20 undergraduate researchers, 58 grad students and 25 postdocs.
- 13 funded external grants which were seeded by results from UCGP awards. The total dollar value of the external grants was \$25.5 M, of which \$10.5 M was an Energy Frontier Research Center.
- 193 publications, many in high profile journals, as summarized in **Table 3**.

**Table 3:** Publications Reported, UCGP awards beginning 2011-2017

Journal Name	Counts
Advanced Materials Research	1
Adv. At. Mol. Opt. Physics	1
Acta Metallurgica Sinica	1
Acta Physica Polonica	1
Appl. Supercond.	5
ACS Catal.	1
Applied Materials & Interface	2
App. Phy. Lett	1
Biochemistry	4
Chem. Science	4
Chem. Materials	1
Crystals	1
ECS Electrochem. Lett	1
Emerging Materials Research	1
International Society for Magnetic Resonance in Medicine	4
Journal of Alloy Compound	2
Journal of Applied Physics	3
Journal of Chemical Physics	1
Journal of Solid Ste Chemistry	2
Journal of Magnetic Resonance	4
Journal of Membrane Science	2
Journal of Molecular Biology	3
Journal of Materials Chemistry	2
Journal of Power Scource	1
Journal Non-Crystalline Solids	3

# Chapter 3 – User Facilities

Journal Name	Counts
Journal Physical Chemistry	9
Journal Physics	1
Journal Phys. Condens. Mat.	10
Magnetic Reson	1
Magnetic Reson. Med	2
Materials Science Forum	5
Materials Science & Engineering	2
Nano Letters	3
National Acad. Sci. U.S.A	1
Nature	2
Nature Communications	8
Nature Physics	1
Nature Struct. Mol. Biol	1
NeuroImage	2
Neuroscience	1
Optics Express	2
Physics Review	2
Physics Review B	51
Physics Review Rapid Communication	3
Phys. Che., Chem. Phys.	3
Physics Review Lett	8
Proceeding	9
PLoS One	1
Polyhedron	1
RSC Advances	1
Sci. Report	5
Scripta Mater	1
Spintronic	2
Superconductor Science and Technology	3

Publications (including accepted for publication) as of January 2017, reported from UCGP grants.

**Table 4:** Facility Enhancements Reported from 2011-2017 UCGP Solicitations

PI	Enhancement and available date	users *
Baumbach	Modified 1800 C tube furnace for molten metal flux growth of uranium compounds (1/15)	7
Baumbach	Development of capabilities for hazardous substance handling (1/15)	4
Bowers	Arduino-controlled, NMR spectrometer-synchronized near-infrared high power laser tuning system (8/15)	3
Bowers	Three (3) cryogenic NMR probes, all with through-space optical access (9/12-8/15)	10
Choi	Ac susceptometers (12/13)	8
Crooker	Time-domain THz spectroscopy using TOPTICA Teraflash system	2
Dalal	Variable temperature (VT) magic-angle spinning (MAS) probe for the 900 MHz NMR (6/14)	2

# Chapter 3 – User Facilities

PI	Enhancement and available date	users *
Gor'kov	3.2mm double resonance lowMAS NMR probe for ultra-narrow bore 830 MHz magnet (11/13)	6
Graf	Coil winder for AC susceptibility	5
Graf	Hybrid piston cylinder cell	1
Grant (ultra.)	Relaxation-enhanced magnetic resonance spectroscopy set-up	4
Grant (Mr Farfield)	Dielectric-based cylindrical waveguide structure for the 900 UWB magnet. (12/11)	2
Hill	Improved EMR high pressure facility (11/16)	2
Hu	High-temperature, high-resolution NMR	6
Jaime	Fiber Bragg Grating based magnetostriction pulsed field and DC magnets (3/12)	23
Jarosynski	Reel-to-reel magnetometer for 4.2 K conductor characterization (7/13)	2
Jarosynski	VSM with rotator modified for high torque (4/16)	1
Li	Imaging and measurement of photocurrent and photoluminescence in high magnetic field (9/12)	1
McGill	Probes for Split Helix, free space Raman measurement, Photoluminescence excitation, fluorescence line narrowing, magnetic circular dichroism (12/14)	7
Mielke	Lithographically defined induction coil for pulsed field measurement (4/15)	1
Mielke	Apparatus allowing measurement in pulsed field in He exchange gas (3/16)	2
Reyes	mK ( <sup>3</sup> He and dilution fridge) NMR probes (8/15)	9
Reyes	1 kW, 1GHz NMR power amplifier (10/16)	3
Smirnov	Direct-optics setup for PL, reflectance, Raman magneto-spectroscopy at B<14.5T and T=4-300K (6/15)	10
Song	Facility to process samples before biological and chemical EPR measurements (6/13)	13
Takano	Force magnetometers for unprecedented low T, high B (11/12)	2
Zapf	Faraday magnetometer for the 20 T (6/13)	1
Zapf	Expanded range of magnetic field sweep rates in the 60 T shaped-pulse magnet (8/12)	5

\* Number of external users (PI's only) reported to have used the enhancement.

# Chapter 3 – User Facilities

## 3.2.2. Dependent Care Travel Grant Program

Eligible recipients are early career scientists, including undergraduate and graduate students, postdocs, and scientists with fewer than 10 years of active professional work since receiving a Ph.D. To be eligible, a scientist must be either:

- An early career user traveling to a MagLab facility in Tallahassee, Gainesville, or Los Alamos to conduct an experiment as part of a user program (not including employees of Florida State University, the University of Florida, or Los Alamos National Laboratory).
- A MagLab early career scientist employed by any of the three MagLab partner institutions who is selected to present results at scientific meetings, conferences, or workshops.

A dependent is defined as 1) a child, newborn through 12 years of age (or any physically or mentally disabled child under the age of 18 who is unable to care for himself or herself), who resides with the applicant and for whom the applicant provides primary support, or 2) a disabled adult/elder (spouse, parent, parent-in-law, or grandparent) who spends at least eight hours per day in the applicant's home and for whom the applicant has responsibility.

The Dependent Care Travel Grant Program (DCTGP) is described in detail at <https://nationalmaglab.org/user-resources/funding-opportunities/1126>.

In 2017, four scientists benefited from this funding. One external user Dr. Elizabeth Green (F) used the funding to pay for child care support while she measured samples at the MagLab in October 2017. Two MagLab postdoctoral researchers applied and received funds during 2017. Dr. Rongmei Niu (F), a postdoc in MST, and Dr. Priscila Lalli, a postdoc in ICR, used the funds to pay for child care support while they traveled to conferences in August 2017 and June 2017, respectively. Dr. Dagmar Weickert, a Research I faculty member at the MagLab, utilized the funds to pay for child care support at a conference in July 2017.

## 3.2.3. First-Time User Support

The NHMFL is charged by the National Science Foundation with developing and maintaining facilities

for magnet-related research that are open to all qualified scientists and engineers through a peer-reviewed proposal process. Facilities are generally available to users without cost. In an effort to encourage new research activities, first-time users are provided financial support for travel expenses. International users are provided \$ 1,000 of support and domestic users are provided \$500 of support for their travel costs. This funding is provided by the State of Florida and is available for Tallahassee user facilities only.

## 3.2.4. Visiting Scientist Program

The National High Magnetic Field Laboratory provides researchers from academia, industry, and national laboratories the opportunity to utilize the unique, world-class facilities of the laboratory to conduct magnet-related research. In 2017, the Visiting Scientist Program provided a total of \$49,618 financial support for 9 research projects on a competitive basis. The primary intent of this program is to provide greater access to the unique facilities at the MagLab and to seed research programs that help advance the laboratory. State funding is being used and principally intended to partially support travel and local expenses. Requests for stipends are considered but given a lower priority. The amount of support generally ranges from a few thousand to \$20,000. Beyond conducting the research as approved and maintaining fiscal integrity, the researcher has one additional responsibility, which is to provide the MagLab with a progress report on request and a final report on their research to be included in the online version of the NHMFL Annual Report. Participants in the NHMFL Visitors Program are expected to acknowledge support provided by the NHMFL in any publications coming from work during their visit or collaboration with the NHMFL. To apply for support from the Visiting Scientist Program, interested researchers are required to submit an application and a proposal that will be reviewed by appropriate facility directors and scientists at the NHMFL. All requests for support must be submitted online at <https://vsp.magnet.fsu.edu/> at any time throughout the year.

# Chapter 3 – User Facilities

## 3.3. User Advisory Committee Report (*Unedited Version*) Report on the 2017 NHMFL User Advisory Committee Meeting Held in Gainesville, FL, from October 20th to 21st, 2017

**Chair:** Madalina Furis, Department of Physics, University of Vermont

**DC/Pulsed/High B/T Vice-Chair:** Sara Haravifard, Department of Physics, Duke University

**NMR/MRI/ICR/EMR Vice-Chair:** Dane R. McCamey, School of Physics, The University of New South Wales

### **User committee members:**

**DC/High B/T Committee:** Madalina Furis (Users Committee Chair, University of Vermont), Malte Grosche (Cambridge University), Zhigang Jiang (Georgia Institute of Technology), Lu Li (University of Michigan), Philip Moll (Max Planck Institute for Chemical Physics of Solids), James Williams (University of Maryland), Elizabeth Green (Dresden High Magnetic Field Lab), Sara Haravifard (Chair for DC/ High B/T Duke University), Haidong Zhou (University of Tennessee)

**PFF Committee:** Chuck Agosta (Clark University), Kirsten Alberi (National Renewal Energy Lab), Nicholas P. Butch (NIST Center for Neutron Research), Krzysztof Gofryk (Idaho National Lab), Jamie Manson (Executive Committee Member, Eastern Washington University), Filip Ronning (Los Alamos National Lab), Zhiqiang Mao (Tulane University), Pei-Chun Ho (California State University, Fresno)

**NMR/MRI Committee:** Brian Hansen (University of Aarhus), Eduard Chekmenev (Chair, Vanderbilt University), Oc Hee Han (Korea Basic Science Institute), Doug Kojetin (Scripps Research Institute), Len Mueller (Exec. Committee, UC Riverside), David Bryce (University of Ottawa), Paul Ellis (Doty Scientific, Inc.), Richard Magin (University of Illinois at Chicago), Doug Morris (National Institute of Neurological Disorders and Stroke), Aaron Rossini (Iowa State University)

**EMR Committee:** Chris Kay (University College, U.K.), Dane McCamey (Chair, University of New South Wales, Australia), Stefan Stoll (University of Washington), Joshua Telser (Roosevelt University), Hannah Shafaat (Ohio State University), Stergios Piligkos (University of Copenhagen), Lloyd Lumata (University of Texas), Erik Cizmar (P. J. Safarik University)

**ICR Committee:** Jonathan Amster (Chair, University of Georgia), Michael L. Easterling (Bruker Corporation), Ying Ge (University of Wisconsin), Kristina Hakansson

(University of Michigan), Ljiljana Paša-Tolić (Pacific Northwest National Laboratory) Michael Freitas (Ohio University Medical Center), Elizabeth Kujawinski (Woods Hole Oceanographic Institution), Forest White (MIT)

On behalf of the User Committee, we would like to thank the magnet lab leadership and staff, especially the representatives of the high B/T facility for the flawless organization of the User Committee meeting. The meeting was very productive with highlights that included an extended brainstorming on the possibility of tapping into future mid-scale instrumentation funding opportunities at NSF, exciting new experiments in development at the pulsed field facility, the first architectural renderings of the user housing projects and a very interesting workshop on the progress of spectroscopy techniques at the lab organized in response to a user committee request from the previous year. We are very grateful to all three hosting institutions (FSU, UF and LANL) for their unflinching support of high magnetic field science. We are very confident that all three branches of the magnet lab will to be involved in transformative research across many disciplines, and we are excited and optimistic to see how the three sites will evolve in the future.

### **(1) Executive summary**

Before addressing issues pertaining to the individual facilities which arose from the various subcommittees, we would like to first discuss general developments which affect all the subcommittees at the NHMFL (and the broad user community). The remainder of the report details specific issues which are unique to the different subcommittees.

#### **(i) Outcome of the Renewal**

The User Committee was pleased to hear that NSF will continue to support the high magnetic field science. However, the user committee members unanimously expressed their concern about the future of new magnet technologies developments that were originally projected to make significant headway in the next five-year funding cycle.

The User community strongly supports the lab's broad vision for the future of high magnetic field science. Unlocking the quantum world of strong electronic interactions must remain a priority for the lab. It



# Chapter 3 – User Facilities

demands the exploration of a large thermodynamic parameter space that requires pulsed magnetic fields as high as 135T and DC fields of 60T. This vision cannot be realized without a new generation of revolutionary magnet technologies coupled with complementary experiments that push forward the frontiers of sensitivity, spectral resolution or vibration control.

The user committee members will encourage the entire user community to assist the Maglab leadership in their quest for alternative sources of funding to realize this vision, that include the mid-scale instrumentation programs at NSF. A survey was launched shortly after the UC meeting ended, polling the users on their view of the future magnet technology that is critical for the central science theme in their field of research. The responses received so far converge towards a central theme that transcends almost all disciplines and research communities represented in the user pool: understanding electron interactions and complex emergent behavior in quantum systems.

The future of electronic materials lies beyond Moore's Law, a realm where strong electron interactions cannot be understood without a well-controlled energy scale that is comparable to crystal field splittings and other relevant interactions. In the past, similar considerations were applied to semiconductors where these energy scales were of the order of 30T or less.

A 60T superconducting magnet with larger bore sizes and long operation times would revolutionize electronic materials and devices in a similar way, introducing quantum systems such as high  $T_c$  superconductors, organic semiconductors and magnets, topological 2D systems into an entirely new generation of devices. Such a magnet would also accommodate new techniques that were either incompatible or limited with the old hybrid, resistive or pulsed technologies. The range of interdisciplinary experimental approaches that combine thermodynamic measurements with spectroscopy techniques (NMR, EPR, MRI, Optics, X-ray) will be dramatically enhanced by the superconducting technologies.

Fundamental understanding of quantum processes in complex molecules (including those involved in processes in live organisms) and molecular assemblies emerged as the second interdisciplinary area where there is a critical need for understanding quantum electronics processes with fields of the order of 60T.

In many cases the strong interactions in quantum systems far exceed the 100 T magnetic field range. This

is reason why the pulsed field technologies must grow in parallel to the DC field technologies. While more restrictive as far as the experimental techniques they can accommodate, pulsed fields remain essential in providing insight into the next revolutionary step in quantum materials and a direction for future DC field technology development.

In conclusion, we firmly support the MagLab's plan to develop 60T DC superconducting magnet and 135T pulsed magnet technologies in tandem, in order to maximize the thermodynamic parameters space and accelerate discovery in this broad class of materials and systems that respond to a large variety of societal needs.

## (ii) Staff Performance

We commend user support staff (technical and admin) for their excellent performance throughout the year. The post-experiment user feedback is overwhelmingly positive. Users report minor issues such as equipment malfunctions that are usually addressed by staff in a timely manner. Their expertise is recognized and much appreciated.

## (iii) Housing

The entire user community is extremely grateful for the institutional support provided by FSU in funding the guest house. One of the main concerns has been accommodation, specifically for early career investigators with limited funding. This will be a great opportunity to reduce travel expenses. The close proximity of the guest house to experiment hall will significantly ease the transportation cost and provide secure and safe environment for users 24hrs a day/7 days a week. The committee is pleased with the amenities considered for the guest house which can further lower the costs and improve the productivity of the users significantly. The committee applauds the plans for the guest house to be managed by MagLab and very much appreciates the non-profit nature of the operations as these measures will ensure low per night stay cost. The users enthusiastically are looking forward to the opening day on January 1, 2019.

## (iv) Future hiring strategies

NHMFL is currently in a fortunate period of exciting new experimental techniques developments that are merged into the users program at all three facilities. At the DC facility new magnets are coming online in a

# Chapter 3 – User Facilities

matter of months. This expansion of technical infrastructure will require adequate technical support as well as scientific guidance and leadership. We are certain these unique scientific opportunities, enabled by the cutting-edge technologies, will attract exceptional talent at the lab. We are therefore delighted to hear about new possible faculty hires at UF with ties to the AMRIS and high B/T facilities and the new mid-career NMR scientist search. We strongly emphasize the need for a similar hiring plan at the DC facility.

## (v) Diversity & Outreach

The User Committee is once again impressed with the maglab continued commitment to their long term for increasing diversity. The outreach staff is doing a fantastic job. The increasing media presence is really good. The new website, podcasts, youtube channel, the summer school for girls and graduate students the K-12 activities, the twitter feed are all fabulous. Keep up the good work!

## (vi) Safety

The new risk management and safety policies and procedures implemented a few years ago are strictly observed. Users' feedback indicate all staff observed this procedures across the board and the users are adequately trained and briefed by the NHMFL staff upon arrival. Users feel very safe while conducting research at the lab.

## (vii) User Committee Changes

The UAC elected a new vice-chair for resonance (Stefan Stoll). There was also a discussion related to the scheduling of the out-brief with institutional representatives. It was agreed that the committee can accommodate a change in the schedule such that the out-brief can happen at the end of the business day on the first day of the meeting.

## (2) Report of the DC/High B/T Facility Users Committee

### Contributors to the DC/ High B/T report:

The committee is comprised of:

Sara Haravifard (Chair for DC/ High B/T Sub-Committee, Duke University) Malte Grosche (Cambridge University), Zhigang Jiang (Georgia Institute of Technology), Lu Li (University of Michigan), Philip Moll (Max Planck Institute for Chemical Physics of Solids), James Williams (University of Maryland),

Elizabeth Green (Dresden High Magnetic Field Lab), Haidong Zhou (University of Tennessee) Madalina Furis (Users Committee Chair, University of Vermont)

## Progress Report

During the 2017 annual User Meeting the DC field user subcommittee was briefed on the current status of the facility as well as on the ongoing efforts and developments aimed to address prior user recommendations and to expand and improve the capabilities for the user program. The DC Field user subcommittee particularly applauds the progress achieved in the past year in:

millikelvin Facility Expansion where space for two 32 T all SC magnets has gone under construction with copper screens installed in walls for improved shielding and noise reduction, and non-magnetic bars and reinforced concrete used in the pits for enhanced magnet safety. The subcommittee is very pleased with the on-schedule progress for the magnet development and testing for the 32 T all SC, as well as the simultaneous planning for the needed sample environment to avoid any unforeseen delays, with major cryostats already arrived onsite and projected to be installed in summer 2018.

Enhanced Safety Measures in the infrastructure maintenance and new design efforts with the installation of double block and bleed valves in high pressure magnet cooling water circuit; consideration of an isolated space, separate instrumentation grounding system, and the gas-escape route in the pit design for the two 32 T all SC magnets to address safety concerns in case of magnet quench and compete failure; design and construction of dedicated trenches to hold instrument cables in place in order to prevent tripping hazards. The subcommittee acknowledges and further supports the constant efforts by the NHMFL in reviewing and refining the Integrated Safety Management procedures on case by case bases with the goal to eliminate work space hazards both for the NHMFL staff and users.

Development of the Series Connected Hybrid (SCH) Magnet with 36T achieved in November 2016 and stability of 1 ppm reached in April 2017. The subcommittee is very excited about the prospect of having the SCH system available in the user program for the 2018-1 cycle.

Development of the 41.5 T Resistive Magnet specifically with the upgrade in the vibration isolation system

# Chapter 3 – User Facilities

anticipated to be delivered early in 2018. Subcommittee specifically supports the the planning efforts by the NHMFL for the needed sample environment with cryostats already being ordered and scheduled to be installed in 2018. The subcommittee is looking forward to having the 41.5T magnet ready for the user operation in 2018.

General Infrastructure Upgrade efforts with improvements made in powder supply operations to reduce noise; purchase of additional lock-in, amplifier, voltage control units to facilitate supply-demand cycle; and plans for heat exchanger in magnet cooling water to be installed during the next shut-down.

Outreach Activities specifically the efforts in hosting annual MagLab Summer Schools for graduate students and postdocs, organizing regular public tours and various educational programs for undergraduates and high school students. Subcommittee also is grateful for the innovative outreach programs developed during the last year, specifically the launch of the Fields Magazine in which various NHMFL capabilities are introduced. Moreover, featuring user interviews in the magazine not only provides exposure for young investigators but also facilitates the formation of a network of users with mutual research interests and enhances collaborations.

## Recommendations

Expressing deep appreciations for the ongoing efforts by the NHMFL in proving the cutting-edge facility for diverse network of users, the DC field subcommittee provides following recommendations:

Ensuring Adequate Staff and Support, especially with the expansion of the milliKelvin facility and addition of new magnets to the user program, it is of vital importance for the MagLab to consider new hires both for technical and scientific support to balance the workload and maintain the high level of support it has been providing to users. Furthermore, the subcommittee recognizes the need for a new hire to fill a vacant position to provide user support for thermal transport measurements. This is an important recruitment as it will enable users to take full advantage of the unique capabilities available in the MagLab to perform thermal transport measurements such as heat capacity and thermal conductivity under high magnetic fields. Such addition will not only help the community in obtaining better understanding of quantum emergent phenomena in condensed matter physics but will also

result in attracting new users with diverse research interests to the facility.

Measures to Address Oversubscription and Shorten Waiting for Magnet-Time, remain as one of the key concerns of the user community. With the conclusion of the upgrade phase, normal user operation is expected to resume beginning in January 2018. However, the subcommittee reiterates the importance of new recruitments both for technical and scientific support to ensure full implementation of the new magnets in the user program, address growing number of new users, and maintain the high productivity of the magnet-times. Moreover, the addition of new magnets to the facility and the increased demands for magnet time, calls for reconsideration of weekend operations in order to ease the scheduling limitations.

Data Management Plan, is an important component of the user program. Subcommittee recommends specific clarifications to be issued to the user community with details about the Data Management Plan at the DC facility including the timeline for local data storage and back up process. It is specifically important to modernize the data collection and storage process for MagLab owned local computers in order to facilitate possible future data recovery – for example unique extensions can be automatically assigned to data collected during each magnet-time. The subcommittee also recommends strengthening security measures for accessing the stored data on MagLab owned computers – for example the stored data can be encrypted and only accessed through sign-in process by team members assigned to each proposal/experiment.

Proposal Review Process, and particularly the peer-review aspect of it has been one of the key components of the successful user program, ensuring the high scientific merits for the projects approved for magnet time at NHMFL. The subcommittee notes the need for development of a standard procedure for the review process in order to establish a timeline for the reviews to be submitted. The subcommittee recommends all review requests sent to potential referees to specify due dates by when the reports need to be submitted. Furthermore, the subcommittee recommends that automatic reminders to be sent to the referees in case the due date is missed. This process should ensure that all new proposals are reviewed on time before scheduling period for each cycle.

Tracking User Progress and Accurate Citation of work produced from data collected at MagLab, is an

# Chapter 3 – User Facilities

important measure to assess the science enabled by the facility. For that matter the subcommittee recommends a step to be added to the magnet-time request process, in which the submitters are asked to acknowledge and agree to the terms and specific wording needed for the proper citation of the work resulted from data collected at the NHMFL. Additional reminders can also be included at the time when a magnet-time request is approved and scheduled, as well as when an annual report is submitted. The subcommittee also supports MagLab's proposal to request all users to register for an ORCID number and add their number to their user profile, so that their related publications can automatically be tracked and easily be cited whenever appropriate. The subcommittee suggests that MagLab provides online tutorials and additional help for users who are not familiar with the ORCID database to prevent any unforeseen technical complications specially in case of common names. The subcommittee also recommends that the ORCID number entry to be optional for the first couple of magnet-time cycles in order to avoid any last-minute surprises for the users who are not familiar with ORCID.

Sample Environment, has always been one of the strongest and most important aspects of the user program at MagLab. Expanding the high pressure capabilities to include uniaxial pressure, in addition to further developments for hydrostatic pressure will certainly be of a great interest to the user community. Development of the 60 T DC Magnet, will for sure maintain the DC field's world-leading instrumentation and the subcommittee fully supports these efforts. Addition of a 60 T DC magnet will be a game changer for sure, as it will enable new science to emerge in high fields under a quieter environment compared to pulsed field setting. From studies of normal states of high temperature superconductors, to emergent new states of matter such as Bose-Einstein condensation in quantum magnets at high fields, to quantum oscillations in topological systems, all will tremendously benefit from the 60 T DC magnet development. Such capability not only provides a calm environment needed to probe the critical quantum phenomena but also enables lower temperatures compared to pulsed field setting, critical for any quantum phase transition study.

## **High B/T Facility Progress Report**

The subcommittee has been very pleased with the on-going progress at the High B/T facility, specifically the unique vibration isolation, and high magnetic field-low temperature sample environment. High B/T is one of a kind facility in the world that operates 24 hours-7 days a week, with 39% registered international users requesting to perform experiments. The subcommittee is grateful for the supports provided by the host institution, especially the considerations for new faculty recruitments at UF with research interests matching the current goals of the lab.

Sample Environment progress in the past year has not been limited to low temperatures down to ~ 7mK but the new effort in development of high pressure capabilities at mK temperatures has been of great interest to the user community. Furthermore, the subcommittee is grateful for the development of LHe purifier by undergraduate students.

Outreach: High B/T has continued its active outreach and educational program with on-going REU programs as well as regular public lab tours. Currently five recent PhD students are using the facility for their thesis research.

## **Recommendations**

Long wait time and oversubscription has been a recurring concern of the subcommittee and the user community in general. Access to higher fields certainly is also of great interest to the user community.

The subcommittee recommends nomination of new members with specialized expertise in ultra-low temperature physics for future user committee elections, aiming to add expert members in the field to better represent the needs of the High B/T facility.

Parking limitation has been of great concern to the users. The subcommittee recommends resources to be provided to address the lack of dedicated parking space for the users of the High B/T facility.

## **(3) Report of the PF Facility Users Committee Contributors to the PF report:**

### **The committee is comprised of:**

Chuck Agosta (Clark University) Kirsten Alberi (National Renewal Energy Lab) Nicholas P. Butch (NIST Center for Neutron Research) Krzysztof Gofryk (Idaho National Lab) Jamie Manson (Chair, PFF Sub-Committee, Eastern Washington University) Filip Ronning (Los Alamos

# Chapter 3 – User Facilities

National Lab) Zhiqiang Mao (Tulane University) Pei-Chun Ho (California State University, Fresno)

During the meeting the pulsed field user committee was presented with current status of the facility and its existing measurement capabilities. A significant part of the review has also been devoted to ideas and future plans for advancing magnet technology and measurement techniques. The pulsed facility at Los Alamos National Laboratory is the world leader in generating the highest (non-destructive) magnetic fields up to 100 T. Despite the millisecond time scale of the peak field, the facility offers a wide selection of experimental techniques that can be performed at low temperature and under pressure. We commend the LANL pulsed field facility (PFF) for providing consistent and reliable performance. Last year close to 8000 pulses were generated for ~180 users. The cutting edge research conducted at the pulsed facility is only possible through their outstanding support to the users. Pulsed field facility users recognize and appreciate the support they receive at the PFF. We also recognize generous support from LANL of nearly \$1.5M for facility upgrades (breakers and capacitor banks). This ensures the sustainability of the program. The mixture of outstanding expertise and involvement of exceptional staff creates a unique and very successful research environment.

The committee is pleased with the PFF's ongoing effort to repair the 60 T long pulse magnet. This measurement capability is critical for a variety of experimental efforts and is needed to enable future scientific discoveries. We commend the PFF's strong efforts to identify failure mechanisms and make design improvements throughout the re-build. However, the extended timeline for replacing the damaged coils (with an estimated two year total timeframe) highlights a greater challenge to maintain measurement capabilities at high pulsed fields in the event of a magnet failure. The PFF has expressed a desire to have spare coils on hand to accelerate re-builds of the 60 T long pulse and 100 T magnets, an approach that has helped to keep 65 T short pulse magnetic capabilities going amid magnet failures. The user committee fully supports this approach.

The user committee recognizes that there are critical materials that are needed to keep the pulsed magnet program operational and moving forward. Specialized wire, in particular wires made of Glidcop and copper-niobium are high on the list of materials that are

necessary to construct magnets, that are single source, and that have very long lead times. We urge the NHMFL to fund sufficient wire purchases to make spare magnet shells available to repair failed magnets. These specialized wires are also necessary for the development of new higher field magnets. Finding other sources for these wires, or forming collaborations with other facilities in the US or around the world may help securing a supply of advanced wire into the future. We also urge the NHMFL to continue to support and expand the facilities in Tallahassee to be able to do as much custom modification of wire in-house.

Regarding ongoing efforts to improve measurement capabilities at the PFF, we were updated on the status of the development of pressure cells for use in pulsed field magnets. Substantial progress has been made on the development of specialized diamond anvil cells that are capable of applied pressures up to 6 GPa and temperature stability in a liquid cryogen environment. The diamond anvils have been designed to incorporate electrical leads with an eye toward reliability and ease of use when they are deployed in the user program. This development was performed in response to request from users last year. Despite not having been included in the renewal proposal, this was carried out through the generous support from Los Alamos National Laboratory, which continues to back the pulsed field user program. There was a promising demonstration of this concept with a graphite sample and measurements under pressure will be proven soon. We look forward to the deployment of these cells in the user program, which will, for example, make possible studies of pressure-tuned physics in quantum materials. Lithography, etching, and other processing are fundamentally important to these small and complicated sample environments, and we encourage the exploration of applying focused ion beam techniques to anvil and sample preparation. We also encourage the development of uniaxial strain clamps and hydrostatic piston-cylinder clamps for use in pulsed magnetic fields.

Studying samples under simultaneous extreme conditions of high field, low temperature, and high pressure is vital to our understanding of electronic self-organization. We encourage the PFF to design and build a dilution refrigerator for use in the pulsed field magnets. Initial estimates suggest that the base temperature of measurements will be extended down to at least 0.15 K, which is an important improvement

# Chapter 3 – User Facilities

for the study of quantum oscillations, topological superconductivity, and quantum criticality. The investigation of these and other emergent electronic effects will be facilitated by mounting the pressure cells in the dilution refrigerator.

The user committee recognizes the tremendous potential for using focused ion beam (FIB) machining of samples for measurements in high magnetic fields. This is particularly impactful for metallic samples in pulsed magnetic fields, where eddy current heating limits the ability to perform transport measurements in time varying fields, and increases signal to noise in a limited measurement time window. Work on heavy fermions, spin liquids and topological materials over the past year that would not have been possible without FIB machined samples demonstrate the value of this technique. This becomes particularly important as the magnet lab pushes towards higher magnetic fields, which will certainly require higher sweep rates resulting in even larger heating issues. Additionally, FIB micro-machined devices will be advantageous for pressure measurements given the small sample space. As such, we encourage the magnet lab to hire staff to develop this as a capability and make it available to the user community.

Another capability, which we believe would be valuable to the community are ultrasound measurements in pulsed magnetic fields. Ultrasound measurements up to 95 T have been demonstrated in TaAs, and provide thermodynamic evidence for a phase transition, at such high fields. Ultrasound measurements additionally provide directional information, and hence can be used as a symmetry resolved probe, which is particularly valuable for exploring fluctuations and static order which are anisotropic. Given the interest in unconventional superconductivity, electronic nematic orders, spin fluctuations, and topological order could all exploit this capability. We encourage the magnet lab to make this capability available to more users.

The pulsed-field facility continues to do an exceptional job at supporting the needs and requests of the users. In support of the PFF's effort to provide world-class capabilities to users, the user committee also backs the purchase of smaller items that would expand those capabilities. Among other items, we encourage the purchases for improving the infrastructure and the reliability of the pulsed field magnet program, as well as enhancing the magnet lab's ability to fully exploit the

unique capabilities of this world class facility, which cannot be found elsewhere in the US or the world.

The user committee supports the plan to extend pulsed fields to beyond 100 T. High magnetic fields are critical to the study of many areas of condensed matter physics. Broadly the committee is excited about expanding the phase space of extreme conditions by ~ 35%. This is tremendous and will certainly lead to new, unanticipated discoveries in a similar fashion that extending to 100 T had done previously. Of note, there is an exponential increase in the amplitude of quantum oscillations with an applied field. Higher fields will enable studying the normal state of cuprates, enhanced effects due to Zeeman splitting, mixing of spin-orbit coupled states, and quantum magnets. Of particular current interest is the field of topological materials. Discoveries of three-dimensional topological materials, including Dirac and Weyl semimetals, have attracted enormous interests because they represent new topological states of quantum matter and opened a new era of condensed matter physics and material science. The unique topological properties of the electronic band structures of Dirac/Weyl semimetals result in useful exotic properties such as extremely high carrier mobility and large linear magnetoresistance, which carry great promise for future applications in energy and information technologies. Quantum oscillation measurements under high magnetic fields have been extensively used to characterize the Dirac/Weyl fermion properties, such as effective mass, quantum mobility and Berry phase. One big open question in this emerging field is what new exotic properties will be found in the ultra-quantum limit under extremely high fields. Some current high-field (<92T) studies on 3D topological semimetals have revealed exciting properties near the quantum limit, e.g. quantum Hall effect. If these materials could be pushed to the ultra- quantum limit in the fields above 100T, new quantum states are expected. This includes fractional quantum Hall effects and exotic ordered states due to enhanced correlation. Building a new magnet offering fields greater than 100 T would have significant impact on the understanding of new topological physics, and accelerate the pace of quantum materials' applications in technology.

# Chapter 3 – User Facilities

## (4) Report of the Magnetic Resonance Division User Committees

### Sections: I. NMR and MRI, II. EPR and III. ICR

#### I. NMR and MRI

NMR/MRI UAC and contributors to this section of the report: Brian Hansen (University of Aarhus), Eduard Chekmenev (Chair, Vanderbilt University), Oc Hee Han (Korea Basic Science Institute), Doug Kojetin (Scripps Research Institute), Len Mueller (Exec. Committee, UC Riverside), David Bryce (University of Ottawa), Paul Ellis (Doty Scientific, Inc.), Richard Magin (University of Illinois at Chicago), Doug Morris (National Institute of Neurological Disorders and Stroke) Aaron Rossini (Iowa State University)

#### Overview:

The NMR/MRI user subcommittee (USC) is pleased with the continued progress being made at NHMFL/AMRIS: they are pushing the boundaries of sensitivity and resolution and advancing science that simply cannot be done anywhere else. A major accomplishment this last year has been the acquisition of NMR spectra on the 36 T SCH magnet – this initial work is already demonstrating the incredible insights into chemical structure and dynamics that will be possible. The USC notes some concerns with how this exceptional resource will be made available and scheduled for magnetic resonance community. Additional highlights included reports on the incredible sensitivity of the HTS probe for metabolomics, the continued development of solid-state NMR probes with unparalleled performance, the awarding of the P41 center grant, news of the on-site housing to be constructed adjacent to the Tallahassee site, and the multiple, exciting developments on DNP. For the latter, the USC notes the synergy between the NMR and EPR groups that has contributed to this programs success.

The USC has noted several concerns regarding staffing and its impact on core support and equipment development. We have identified the following as the three highest priority items:

1. Positions needed to be filled: (i) An RF staff scientist to work with Peter Gor'kov (highest priority), (ii) an MRI RF engineer, and (iii) an SCH operator.
2. Fast (>50 kHz) and ultra-fast (>100 kHz) MAS probes need to be developed or purchased for the high-field spectrometers.

3. The magnet lab should re-establish itself as a world leader in micro-imaging.

#### Personnel:

There are several recommendations for future hires that are essential (and these recommendations echo the recommendations from the previous year report): (i) Another staff scientist is needed like Peter Gor'kov. This has been a severely underfilled niche. Peter is a very talented scientist but is stretched far too thin. This is a key hire to relieve the bottleneck for probe development and construction. This position is the highest priority. (ii) An MRI rf engineer is also needed (see notes on establishing Magnet Lab as the leader in the field of micro-imaging). This is crucial for building new coils for the 900 MHz (and other lower fields) and to extend MRI to the Series Connected Hybrid magnet. (iii) the SCH is a huge success both scientifically and engineering wise. Additional staffing is certainly required for the operation of SCH and facilitating the scheduling and working with the users. This additional staff person would help alleviate the overload of the Magnet Lab leadership, which has done a great job of getting the SCH project where it is today: way ahead of the USC expectations.

#### Fast magic-angle spinning (MAS) probes:

The Magnet Lab is an established leader in providing ultrahigh magnetic fields for NMR applications. In order to maximize the potential of these high-field systems, it is critical to ensure also that users have access to the latest in very fast magic-angle spinning (MAS) probe technology. These probes are essential for users to be able to carry out the latest biosolids experiments, in particular those that rely on proton detection, as well as experiments on quadrupolar nuclei in biosolids and materials. The USC recommends that all high-field solid-state NMR instruments be equipped either with commercial or home-built very fast MAS probes, e.g., probes for 1.3 mm and/or 0.7 mm rotor-diameter. It should be a top priority to develop analogous very fast MAS probes which spin in the 100 to 150 kHz range for the SCH system. Such developments may place additional strains on the time and resources of Peter Gor'kov, and this is another reason why it is essential to hire additional staff with expertise in rf electronics and probe construction. This may also present an opportunity to bring in trainees through an rf probe construction program analogous to what has been

# Chapter 3 – User Facilities

implemented for building MRI coils. Fast MAS infrastructure is an area where the Magnet Lab is deficient, and could jeopardize the Magnet Lab's ability to attract users in the future. Laboratories in Europe, for example, are far better equipped in this regard.

## **Micro-Imaging:**

The Maglab employs some of the world's leading experts in MR microimaging and MR microscopy (MRM). However, due to challenges related to both hardware and scanner software these programs have been hampered. We strongly recommend that the NHMFL should make it a priority to re-establish its position as a world-leader in micro-imaging and MRM. The impressive developments in magnet technology at the Maglab provide ideal circumstances for this effort. Previous MRM programs have relied on collaborations with commercial NMR vendors. However, currently these companies do not have a strong interest in hardware development for MRM (due to this being a limited market). We therefore recommend that the Maglab supports collaborative fabrication with small businesses which focus on the development of strong and fast gradients and micro-rf coils (ideally double tuned) coils for MR microscopy applications at > 14.1T. Such a collaboration would have as its end objective a technology transfer to MRM programs within the Maglab. In this connection we note that the MRI coil workshop progress has been a great success and very valuable for training and knowledge transfer.

MR imaging is an iconic technique which has revolutionized clinical medicine and biomedical research. There is a strong potential for new discoveries in these arenas if imaging related research is prioritized in relation to the Maglab's new magnets (especially the upcoming 32T). Because of the medical potential inherent in this line of research, the Maglab should consider vetting the level of commitment from the medical departments at UF in relation to the inherently multidisciplinary imaging research.

## **Series-Connected Hybrid:**

The USC was extremely impressed with the initial results of the SCH and believe that there will be very strong interest from the community to use the system moving forward. The primary concern with the SCH we had is that the magnet time for NMR is limited and that rigid scheduling of time may impede access and lead to inefficient use of the instrument. We recommend that

the scheduling of SCH time be done in the most flexible method possible to maximize access to the instrument.

## **DNP:**

DNP, in its many forms, is a core strength of the magnet lab! The USC is pleased with the development of the MAS and Overhauser DNP systems and programs. We are very excited to hear about the perspective of developing additional probes for the MAS DNP system. We strongly support the development of a helium MAS DNP system as this could provide further gains in sensitivity of ca. 2 orders of magnitude. The hiring of Dr. Mentink-Vigier is also a very positive development. He is a world leading expert in the theory of MAS DNP and given his strong EPR background he will contribute positively to enhancing collaborative efforts with the EMR group.

## **Synergies with EMR:**

The USC was impressed by the continuing cooperation/collaboration between the EMR and AMRIS NMR/DNP groups.

## **NSF RFI:**

Regarding the RFI for mid-scale instrumentation, the USC is very supportive of the leadership efforts and places a priority on next-generation, persistent high-field magnets for NMR and MRI.

## **ORCID:**

The USC strongly supports the adoption of ORCID for tracking users' publications.

## **Automated Time Notification:**

The USC would like to encourage that notification be sent out once NMR time is awarded and scheduled. This notification should include a reminder (and the language) about citing the core grant.

## **Outreach:**

The USC would like to highlight the outreach and educational activities by the NMR/MRI staff at the NHMFL. The RF coil development workshop in particular is innovative, and USC suggests that similar outreach be performed on NMR probe technology. We additionally note that Peter Gor'kov should have protected time for teaching the RF-probe knowledge to the broader community through training of students and postdocs, and publicizing the results of his research work on the



# Chapter 3 – User Facilities

RF-probe development.

## Concluding Remarks:

For continuous progress in NHFML, the USC recommends (i) the flexible scheduling of SCH time to maximize access to the instrument, (ii) a priority on next-generation, persistent high-field magnets for NMR and MRI for the RFI on mid-scale instrumentation, (iii) publicizing Peter Gor'kov's RF-probe development results, and

(iv) the continuing collaboration between the EMR and AMRIS NMR/DNP groups. We also note the following three highest priority items:

1. Positions needed to be filled: (i) An rf staff scientist to work with Peter Gor'kov (highest priority), (ii) An MRI RF engineer, and (iii) an SCH operator.
2. Fast (>50 kHz) and ultra-fast (>100 kHz) MAS probes need to be developed or purchased for the high-field spectrometers.
3. The magnet lab should re-establish itself as a world leader in micro-imaging.

## II EMR

### EMR UAC and contributors to this section of the report:

Chris Kay (University College, U.K.)

Dane McCamey (Chair, University of New South Wales, Australia) Stefan Stoll (University of Washington)

Joshua Telser (Roosevelt University) Hannah Shafaat (Ohio State University)

Stergios Piligkos (University of Copenhagen) Lloyd Lumata (University of Texas)

Erik Cizmar (P. J. Safarik University)

EMR UC: Dane McCamey (University of New South Wales, Australia; Chair), Christopher Kay (University College London, UK), Erik Cizmar (P. J. Safarik University, Slovakia), Stefan Stoll (University of Washington), Hannah Shafaat (Ohio State University), Lloyd Lumata (University of Texas), Stergios Piligkos (University of Copenhagen, Denmark), Joshua Telser (Roosevelt University)

### Program

• The UC acknowledges the contributions that the EMR staff make to both the operation and development of the EMR capabilities, as well as the significant scientific support they provide to the user community.

- The combination of the world-class equipment and staff with outstanding expertise is crucial to the delivery of the EMR user program.
- The EMR program has ~30% new users per year, indicating a vibrant and expanding program.
- Feedback from users remains uniformly positive. No issues were brought forward regarding the operations of the EMR user program.

### Personnel

- The UC is concerned about the impact that the recent departure of postdoc Johannes McKay may have on usability and continued development of the HiPER spectrometer, a particularly sophisticated instrument.
- The UC values the expertise that the EMR scientific staff provide, and appreciates that more cross-training of staff will ensure that unanticipated staffing changes do not impact user operations.

### Capabilities

- The lack of tunable optical excitation is limiting the use of the EMR facility, particularly for studying photoexcited states, which are central to quantum and energy materials research. The UC suggest that the lab acquire an appropriate OPO system and integrate it into the various instruments.
- The UC is happy to see the addition of AWG capabilities to HiPER, and feel that this will have significant impact in a wide range of areas (biological, biochemical, bioinorganic, biophysical, energy materials).
- HiPER sensitivity improvements by adding a resonator, a tapered horn, and new thin layer sample holders would improve the ability of users to investigate smaller and more dilute samples.
- The 20+ year old magnet in the 14/17T transmission system, one of the workhorse instruments in EMR, is approaching its end of life. The UC is concerned that magnet failure will shut down a large fraction of the EMR user program for at least a year.
- The DNP capabilities are highly valuable to the user community, and benefit from the expertise in quasi-optical systems found in the EMR group.
- The UC is excited about the availability of the SCH magnet for EPR experiments. With the recently ordered 950 GHz source, this system will offer users unprecedented spectral resolution.
- We are pleased to see that the EMR group continues to develop new capabilities (eg FD-FT THz,

# Chapter 3 – User Facilities

395 GHz pulsed EPR) and encourage the lab to advertise these capabilities more widely.

## Other

- The UC is pleased to see that the EMR group has organized an Advanced EPR School on theory and applications. This School will train new researchers in EPR and enable them to become effective and efficient users of the EMR facilities. We hope that this initiative will be repeated regularly.

## III. ICR

### ICR UAC and contributors to this section of the report:

Jonathan Amster (Chair, University of Georgia) Michael L. Easterling (Bruker Corporation) Ying Ge (University of Wisconsin)

Kristina Hakansson (University of Michigan)

Ljiljana Paša-Tolić (Pacific Northwest National Laboratory) Michael Freitas (Ohio University Medical Center)

Elizabeth Kujawinski (Woods Hole Oceanographic Institution) Forest White (MIT)

### 1. Facility Overview

The ICR Users' Advisory Committee (UAC) continues to be extremely impressed with the progress of the ICR group. Chris Hendrickson provides outstanding leadership, and has engaged a highly talented group of scientists to lead the various activities of the ICR group. The ICR group continues to make innovative advances in instrumentation, and is currently working on implementing a higher-frequency ion trap that triples the effective magnetic field. Additional efforts over the past year have significantly improved and automated sample analysis, significantly improving the speed and efficiency of sample analysis and therefore optimal use of magnet time. These developments, along with the world-leading state-of-the-art 21T ICR system, continue to place the ICR group at the forefront of the field. This leadership position is well-recognized by the user community, as evidenced by the strong increase in the number of annual users of the facility over the past couple of years, 2015 and 2016. Amy McKenna effectively manages the external proposal process, working with potential users to develop high quality applications. The number of users has doubled since 2014 (note that the overall number of users was approximately constant from 2011-2014). The ICR group now has the second-highest number of users in the

Magnet Lab. In addition to the instrumentation developments, much of the increase in external users can be directly attributable to cutting-edge innovative breakthroughs in petroleomics, environmental and biogeochemistry, nanoclusters, and intact protein analysis. These applications have been enabled by the 21T, but the ICR staff continues to make innovative sample handling developments, as well as novel software tools, that continue to facilitate novel discoveries. Overall, they have been successful in every aspect of activity expected for a user facility.

Within the ICR group, the petroleomics effort led by Ryan Rodgers continues to generate novel insights into complex mixture analysis of fuels, including a new discovery that the environmental weathering of oil leads to a massive increase in the number of chemical structures while also generating a set of toxic byproducts. These results, along with multiple successful collaborations over the past year, should lead to high profile publications for this group. Petroleomics and environmental analysis represent the largest group of users, although the user cohort for carbon cluster analysis has also increased strongly over the past two years. The carbon cluster effort led by Paul Dunk is pushing the boundaries of our understanding of cluster formation, and his enthusiasm for this fascinating chemistry is impressive. On the protein analysis side, Lissa Anderson has led the effort to provide high sequence coverage on an LC-time scale for large proteins, a technique that would be incredibly challenging on any other platform. Collaborations in the protein analysis area include antibody analysis in multiple myeloma as well as p53 proteoform analysis, two very high impact projects. Extending her outreach efforts to biologists at biology-oriented conferences will further increase the impressive user base of this group.

The ICR User Committee feels that the broad efforts of the ICR group are strong and do not recommend narrowing these efforts to focus on any particular projects. The diverse research foci within the current group provide support for a broad variety of users including astrochemistry, biology and biological chemistry, environmental chemistry, geochemistry, and petroleum characterization. In addition to supporting a wide range of users, these efforts also could enable a broader base of external funding support, which may be critical in times of limited federal funding.

# Chapter 3 – User Facilities

## 2. Instrument Developments

Chad Weisbrod presented the instrumentation developments associated with the ICR user facility, which represent one of the most important facets for growth and relevance of the program. While detection at a true 21 tesla magnetic field is truly a novel and exciting platform for mass spectrometry, developing advanced instrumentation to efficiently exploit that analytical advantage completes the picture of providing differentiation from other types of competitive mass spectrometry is essential.

The pace and scope of development for the 21T project is primarily associated with enhancing or onboarding capabilities geared for analysis of large biomolecules with a specific focus on streamlining LC-based real-time approaches. The iterative progression of the dynamically harmonized cell (DHC) variant used by the magnet lab has provided a highly optimized cell in terms of detection sensitivity beyond that described in the literature and development here seems to be near frozen. This is a timely development in efficiency terms as cell modifications create the biggest drag on ICR productivity due to the need to apply lengthy bake out cycles. In addition to the physical changes associated with the cell design, the  $3\Omega$  detection scheme is showing positive progress and will further enable workflows that require high temporal resolving power which is an important differentiator to methods such as TOF which have been shown quite efficient for LC protein studies. One highly significant result highlighted in the report was the tendency of the ICR to preserve isotopic fine structure (ISF) while adding charge density to the trap. The significance here cannot be overstated as the only competitive technology in this space cannot maintain the fidelity of this information with any level of change in the trapped charge magnitude. SWIFT isolation which was first reported over twenty years ago has shown significant improvements in efficiency at the 21T field strength which opens the door for innovative development for new MS/MS protocols for complex mixtures.

Capability for providing dissociation of intact proteins under LC conditions has been enhanced with optimization of ion counts for trap filling which needs to be modulated as a function of molecular weight. Electronic dissociation methods for highly charged proteins have also been significantly enhanced by grafting the proton transfer method developed in an associated lab to reduce the charge distribution

complexity prior to applying ETD. While the aforementioned methods have been proven to significantly increase the observed sequence coverage of intact proteins, the results shown to date have been primarily model compounds.

## 3. Intact Protein Analysis

Lissa Anderson leads the developments and applications in intact protein analysis. These efforts capitalize on the state-of-the-art 21 tesla FTICR mass spectrometer. The Mag Lab ICR group is collaborating closely with the NRTDP, a NIH P41 resource at Northwestern University that is focused on top-down mass spectrometry/ proteomics. The pipeline involves a standard 2D approach, offline GelFree electrophoresis followed by online analysis of collected fractions by LC-21T FTICR-MS/MS. Acquired data are shipped to NRTDP for analysis. (This begs a question how to accommodate other users, esp. users unfamiliar with top-down MS and we suggest bringing data analysis capabilities onsite to expand user base. [all user data will be analyzed on the NRTDP platform, but if this turns out to be a problem we will develop our own analysis platform]) 21T FTICR with front-end ETD platform provides high sequence coverage on the LC time scale and has enabled identification of over 600 human proteins (corresponding to over 3000 human proteoforms) from human colorectal cancer cell lysate (JPR 2017). In collaboration with Mayo clinic, they have also applied this technology to for the first time effectively characterize antibody overexpressed in serum of multiple myeloma patients, setting a high standard for serum antibody MS-based assay. As a part of the NRTDP collaboration, the team acquired first ever spectra of the master cell regulator, human p53. p53 family of genes and their proteins have a wide variety of functions and top-down mass spectrometry will enable us to correlate a multitude of posttranslational modifications often found on these proteins to function and phenotype. This has been an area of extensive research over the last 30+ years and provides multiple opportunities to enrich user base and/or attract new funding. Newly developed data dependent acquisition that includes an adjustable cumulative ion target (CIT), i.e. adjusting ion fill times on-the-fly to account for different molecular mass, as well the addition of PTR-PIP capability holds great promise for top-down applications. Another exciting development is the use of high-resolution ion isolation (SWIFT) in combination

# Chapter 3 – User Facilities

with in-cell UVPD for characterization of closely related proteoforms, e.g. histones. While there is still work to do in order to extend applications to larger proteins and realize the full potential of the 21T in the realm of top-down proteomics, we have seen significant progress already made. There was a lot of discussion by the committee regarding the suitability of supporting NIH funded work with the resources of the magnet lab. Overall the committee felt that this subgroup has made huge strides since hiring Lissa Anderson to direct these activities, and that this is a significant component of the ICR laboratory.

## 4. **Petroleomics and Environmental Chemistry**

Ryan Rodgers leads the activities in the area of Petroleomics and Environmental Chemistry. This group has had another great year. They accommodated a record number of users, including new principal investigators and a large number of graduate students and postdoctoral researchers. The petroleum group is expanding the analytical horizons of chemical analysis through the incorporation of pre-fractionation. These added capabilities have immediate impact for operational problems in the field, thus pushing the boundaries of fundamental chemical knowledge while simultaneously solving real-world problems. Similarly, these tools are being used to explore the mechanisms of petroleum weathering during oil spills. This foundational knowledge will inform future responses to oil spills in marine environments, particularly regarding the use of containment versus dispersant technologies. The largest growing group of users for this team are investigators interested in natural organic mixtures, most notably dissolved organic matter in different aquatic systems. Current users bring large sample sets and will require advances in chromatography and pre-fractionation protocols, similar to those developed for petroleum applications by the MagLab. The committee commends the petroleum / environmental applications group for its outreach and ability to accommodate the burgeoning user community in these fields. We anticipate another good year ahead and encourage the group to further develop advanced tools for compound characterization in these complex mixtures.

## 5. **Nanomaterials and Clusters**

Paul Dunk leads the ICR facility's efforts in the area of nanomaterials and clusters. A dedicated 9.4 tesla FTICR instrument is committed to these studies. This instrument is equipped with a Smalley-type cluster source that uses laser ablation of a graphite rod and a pulsed molecular beam for generating fullerenes and endohedral fullerene complexes. This instrument is used to address important chemical questions regarding the synthesis of fullerenes in hot plasmas. For example, research with this instrument has shown that Sc<sub>3</sub>N endofullerenes bypass C<sub>60</sub> and other states that act as traps for the growth of carbon clusters, leading to the preferential formation of Sc<sub>3</sub>N@C<sub>84</sub>. Interesting mixed clusters have been made by gas-phase chemistry in which boron replaces a carbon atom in fullerenes and endofullerene complexes. Endofullerene complexes with many different clusters inside the fullerene cage are targets for current studies, and FTICR will be essential for establishing the elemental composition of the products. Dr. Dunk is expanding his research activities into the area of astrochemistry, specifically carbon-cluster ions which may be responsible for important diffuse interstellar bands. The user activity for this instrument is relatively modest (7 PI's and 22 users are currently active in the program), but they have produced some high-quality publications.

## 6. **Outreach:**

Amy McKenna is doing an outstanding job of managing outreach activities, which include K-12 activities, programs for middle school and high school students, and mentorship of undergraduate students. Also, the ICR subgroup organizes a biannual meeting, the North American FTMS Conference, which attracts the participation of 100 scientists from around the world, and is an important contribution to the scientific community by the ICR group.

# Chapter 3 – User Facilities

## 3.4. User Safety Training by Facilities

*Safety training, across all facilities, is an important component of the Lab's Integrated Safety Management.*

### AMRIS Facility

All internal and external users that will assist in data acquisition (*i.e.* anyone who will enter the facility without direct supervision of AMRIS personnel) are required to attend a one hour safety class as a first step to getting keyed access. In this class, safe operation in high magnetic fields, working with RF cables, and the principles of Integrated Safety Management (ISM) are presented and discussed. Anyone working with animals is required to carry documentation of their Institutional Animal Care and Use Committee (IUCAC) approved protocol when working with animals in the AMRIS facility. The UF IUCAC office oversees all animal related safety training and authorization of work with animals at UF, including for external users. Users wanting to work independently in the 11 T room (*i.e.* without an AMRIS staff person present) are required to demonstrate instrument proficiency to AMRIS personnel and to attend an additional hour of safety training specific to the 11 T system.

AMRIS personnel have weekly staff meetings, and at each of these meetings we review whether there are any safety issues or training needing discussion. If so, time is dedicated to discussing any incidents or changes in training/operation and ensuring all AMRIS personnel are apprised of them. We also regularly update our web pages to reflect current safety policies. All AMRIS personnel are required to keep both their NHMFL and UF safety training current. Regular inspections of AMRIS facilities are performed by the UF office of Environmental Health & Safety as well as by the IUCAC. AMRIS personnel directly accompany all new users in the facility and regularly interact with experienced users to discuss any issues which might arise during their facility use. All non-routine, increased-risk operations, such as refilling the magnets with cryogens, are performed by trained AMRIS personnel. Any use of cryogens during experiments to cool samples requires additional training in safe handling of cryogens.

All access to the AMRIS facility is via RFID keys; these keys are monitored and regulated through the UF Police Department so we have a record of their use and can revoke access to an individual user at any point in time if needed.

### DC Field Facility

*Users of the DC Field Facility must complete the appropriate online safety training prior to being issued a badge and receiving access to the DC Magnet Building.* Users are assigned training modules that are appropriate to the experiment they are conducting and the part of the facility they will be working in. When magnet time is awarded, the safety training status of the researchers who are traveling to the MagLab is checked by the DC Field User Program Coordinator several weeks prior to their arrival. Any users who either have not taken the required training or whose training has expired are directed to the training website:

<https://training.magnet.fsu.edu/Login/Default.aspx> to take the appropriate training. Users who arrive at the Lab without having completed the training are set up in one of our user offices so that they can complete the training before they are granted access to the magnet cells.

During the user's magnet time they are assigned an in-house scientist as well as a technician in order to provide scientific and technical support. This also ensures that the user performs their experiment in a safe manner. In addition, the control room operators monitor the magnet cells via cameras located in each cell. User operations on the 45 T hybrid magnet are also monitored directly by a hybrid operator who is present on the user platform while the hybrid magnet is in use.

### EMR Facility

#### External Users

Prior to carrying out any experiment at the EMR Facility, every external user is required to pass the on-line safety training course(s) provided by the NHMFL (<https://nationalmaglab.org/user-resources/safety>).

This is currently enforced by the EMR Administrative Assistant, who will not issue a laboratory entrance card or any keys without proof of completion of the required course(s). Prior to an experiment, potential safety issues are discussed individually with each new user. During the actual experiments, each user is accompanied/supervised by one of the EMR science staff. All non-routine or increased-risk operations such as refilling the

# Chapter 3 – User Facilities

magnets with liquid helium or sample changes are performed by the EMR staff rather than the user.

## Internal Users

All of the EMR group members have become familiar with the ISM principles. All of them also attend the Quarterly Director's Meetings. A representative of the EMR group attends the monthly NHMFL Safety Committee meetings and reports on pertinent issues to the EMR group during its meetings.

## High B/T Facility

All members of a user group carrying out experiments at the High B/T Facility must observe all the safety precautions required by the National High Magnetic Field Laboratory and the University of Florida. New users are asked to review the NHMFL Integrated Safety Management plan and to familiarize themselves with the High B/T User's manual (<http://www.phys.ufl.edu/microkelvin/Manuals.html>).

Prior to carrying out an experiment, all members of the user group must pass the on-line safety training provided by the National High Magnetic Field Laboratory. On the first day of their visit, users are introduced to the facility and its layout and the safety precautions for working in the designated area: use of O<sub>2</sub> sensors, covering of all pits, location of safety goggles and tools, and exits in case of a magnet quench, etc. Access to the Microkelvin Laboratory is limited to authorized personnel who will be provided with an access key. All users must comply with the following rules that are specific to the High B/T facility:

1. No user may transfer cryogenic fluids.
2. No user may charge or discharge any magnets in the facility.
3. All undergraduate students must be accompanied by a supervising faculty or staff member at all times.
4. Users may not be present in the lower floor area when the dewars or electromagnetic shields (socks") are being raised or lowered and when the pit covers are temporarily open.
5. All personnel who need to enter the pit(s) must have completed "confined space training" and "fall protection training" with the University of Florida Environmental Health and Safety Department. Users are not permitted to enter confined spaces (pits, crawl spaces etc.) or to platform areas where harness protection is needed.

Access to the High B/T facility is limited to authorized personnel who will be provided with a UF

key for entry. Users will receive a key on notification they have passed the safety training.

Detailed information regarding safety procedures is available on the facility web page at: <http://www.phys.ufl.edu/microkelvin/Safety.html>.

## ICR Facility

All internal ICR personnel and external users that will assist in data acquisition are required to select the labs that they will be working in prior to assignment of safety training. Safety training is assigned based on the working hazards that are within each lab space. For example, each person who will work in the ICR high bay is required to take the following safety training courses: cryogen safety, high magnetic field, general safety, laser safety, and electrical safety. Additionally, no one is allowed to perform any cryogen fills or operate any instrument systems without extensive, supervised, hands-on safety training by an ICR staff member.

All users that will be entering any ICR lab spaces are required to complete online safety training, but are assisted by an internal ICR group member for all sample preparation, instrument start up and shutdown, and data acquisition. All ICR magnet system usage is limited to trained ICR personnel. No external users are allowed to start up or shut down ICR magnet systems. In addition, access to the ICR 21 T high bay is limited to only personnel that have been approved for access to the high bay area. All visitors are required to have an escort at all times, and everyone who enters any ICR lab space (C330, B239, B240, NM 113, and NM 117) is required to wear safety glasses with no exceptions. No food and drink is allowed in any ICR lab space except in designated areas that are marked with appropriate signs. Safety glasses are mandatory at all times in all ICR laboratory and high bay spaces.

## NMR Facility

### External Users

Prior to conducting experiments in the NMR Facility, external users are required to pass all applicable online safety training courses mandated by the NHMFL (<https://nationalmaglab.org/user-resources/safety>). The NMR Administrative Assistant and/or CIMAR Coordinator will not issue a laboratory access card or keys without successful completion of this training.

Prior to an experiment, potential safety issues are discussed individually with new users. Users are

# Chapter 3 – User Facilities

then accompanied/ supervised by NMR science staff while performing experiments. All non-routine or higher risk operations, such as magnet cryogen fills, are performed by trained NMR staff.

## Internal Users

NMR group members are familiar with the ISM and THA (Task Hazard Analysis) principles. They attend the quarterly NHMFL Safety Meetings. A representative of the NMR group attends the monthly NHMFL Safety Committee meetings and reports on pertinent issues to the NMR group during its meetings.

NMR staff and faculty group meetings are conducted weekly. Every 6 weeks a meeting is dedicated to safety, safety issues, and/ or safety training. All members of the NMR group are required to complete and pass the NHMFL online safety training courses, and they are required to keep those trainings current.

## Pulsed Field Facility

Users of the Pulsed Field Facility (PFF) are treated equally to full time employees at Los Alamos National Laboratory (LANL) with respect to hazardous work activities and authorization.

New for 2017 is expansion of the implementation of a “Competent Worker” certification. This allows first line managers the ability to develop criteria for evaluating a worker’s experience and ability and then to verify the person’s competencies in the laboratory environment. This method is needed because LANL uses multiple live training courses that are scheduled too infrequently to be effective for NHMFL users. The Competent Worker concept has helped LANL’s Pulsed Field Facility to be “agile” in meeting the user needs while applying a graded approach towards risk management and worker safety.

LANL workers are educated in a comprehensive approach towards safe work practices within the context of Integrated Safety Management (ISM) before being authorized to perform work activities using a graded hazard approach. LANL’s safe work approach also includes “Human Performance Improvement” or HPI.

LANL has its own HPI program office and training in human performance and error prevention is offered to all employees. The Pulsed Field Facility has

adopted HPI technology and reduced both the incidence and the consequences of mistakes. By adopting and implementing HPI technology and demonstrating the use to peer observers from within LANL and outside the PFF we have been able to reduce the hazard classification of 100 Tesla Science operations from High to Medium. A reduction in error results in an increase in efficiency. However, engineering controls remain the primary control for safety and risk reduction. Engineering controls, e.g. door interlocks, access controls, and key capture systems such as “Kirk Keys,” are used to ensure safe equipment configuration. Access controls are used for all pulsed field operations at the PFF.

Safety management is governed by LANL policies and procedures and work performed at the PFF is categorized into one of three hazard classes (Low, Medium, or High). By default no medium or high hazard work activities are permitted at the PFF unless authorized. Additionally, no PFF users are authorized for high hazard work.

Work categorized as Medium or High Hazard requires a written and approved work control process (called an Integrated Work Document or IWD) and documented work authorization by the Safety Responsible Line Manager (SRLM). All LANL workers (staff and users performing work) use an online system (called U-Train) to assign and track training and work authorization. All users are assigned to a PFF Scientist to assist and support scheduled experiments. When new users arrive they are briefed by the assigned Scientist and the Program Specialist. Then, the Program Specialist, based on the nature of the visit, assigns training to the User. Live training or on-line content is then completed by the User and tracked in LANL’S U-Train database. If moderate hazardous work is to be performed by the user (e.g. operate the PFF User Capacitor Bank) the IWD is read, training is verified by the SRLM, and user competency confirmed with the Person In Charge (PIC) of the work. Then the work authorization is granted by the SRLM. At this time, PFF Users are authorized for the work. All of the infrastructure and management support of the above work control process at LANL is provided by institutional support of programs.

# Chapter 3 – User Facilities

## 3.5. Annual User Program Survey

The National High Magnetic Field Laboratory conducted its seventh annual user survey between June 5, 2017 and June 30, 2017. User input assisted all seven facilities to respond to user needs, improve facilities and services, and guided the MagLab in setting priorities and planning for the future. This request was sent to all MagLab User Principal Investigators (PI) and to their collaborators who received magnet time between June 1, 2016 and May 31, 2017, including PIs who sent samples, where the experiment was performed by laboratory staff scientists.

All user responses were treated anonymously. All presented figures exclude internal responders.

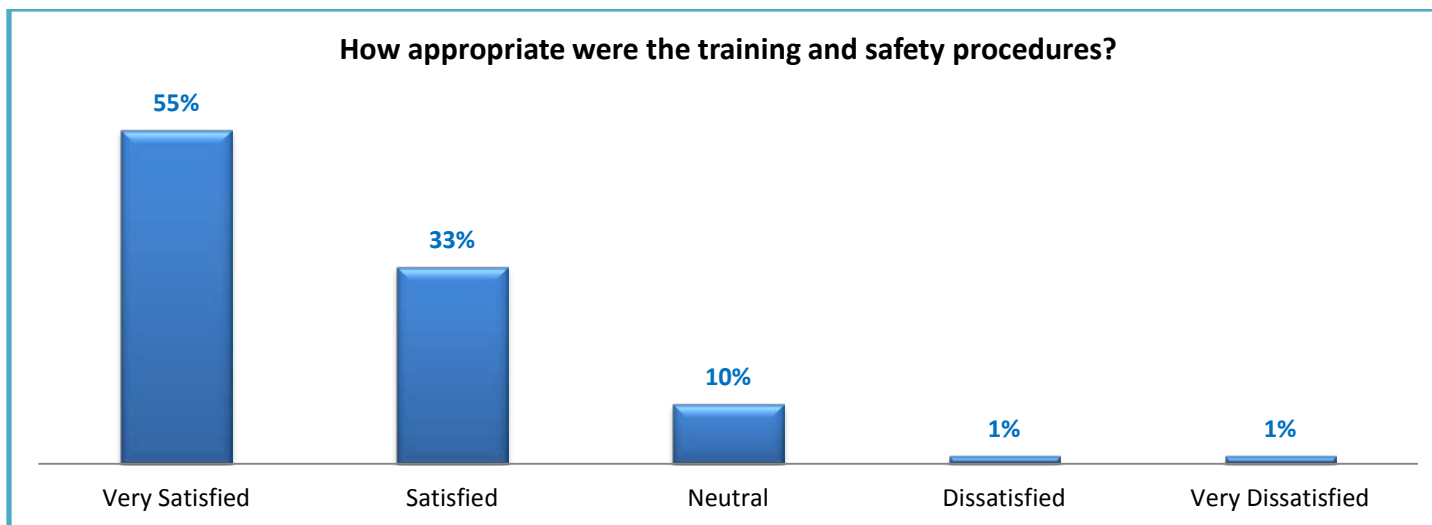
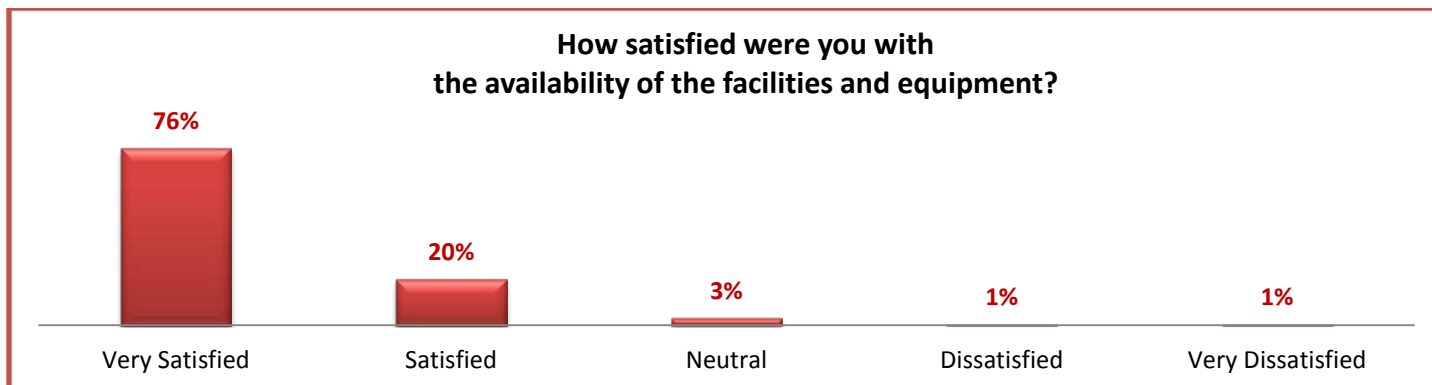
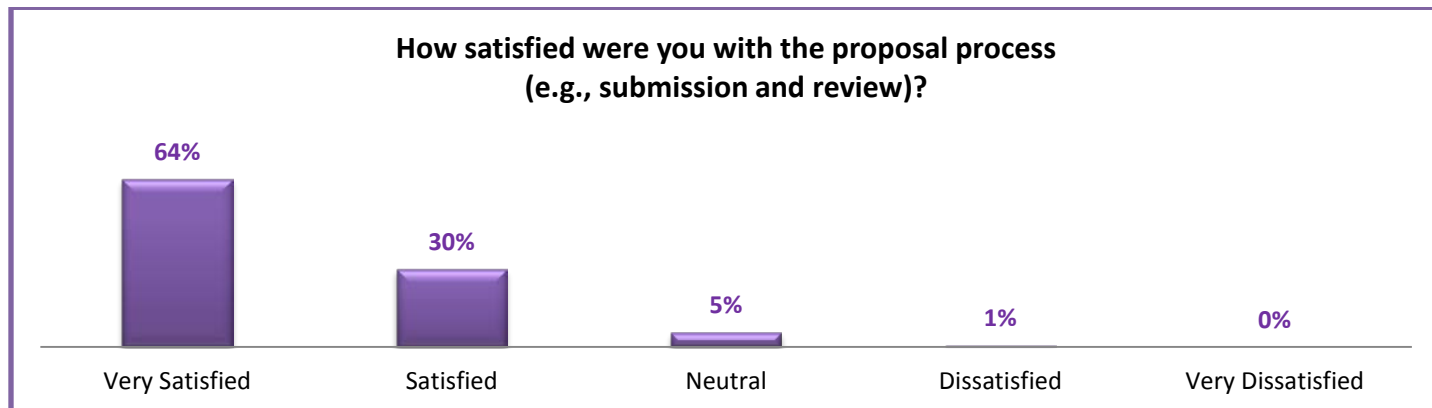



# Chapter 3 – User Facilities

How user friendly were the training and safety procedures?

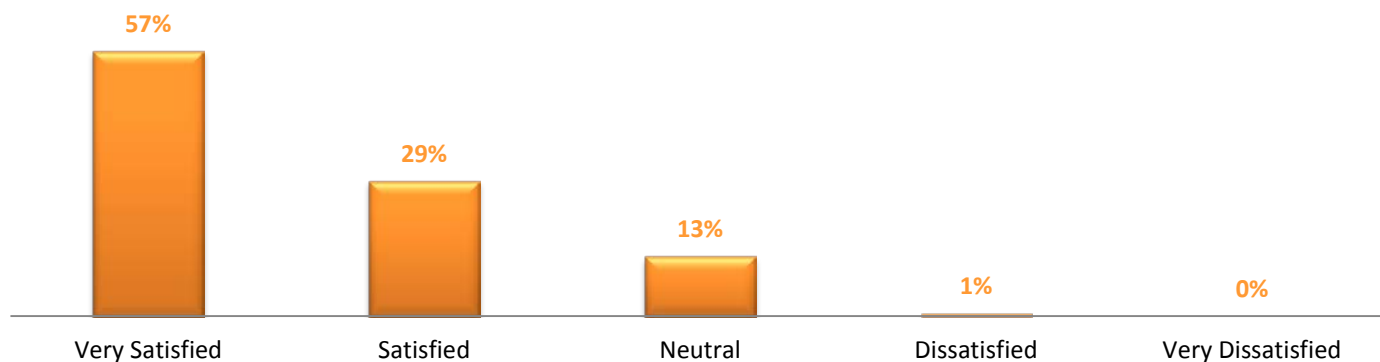

How satisfied were you with the performance of facilities and equipment (e.g., were they maintained to specifications for your intended use, ready when scheduled, etc.)?

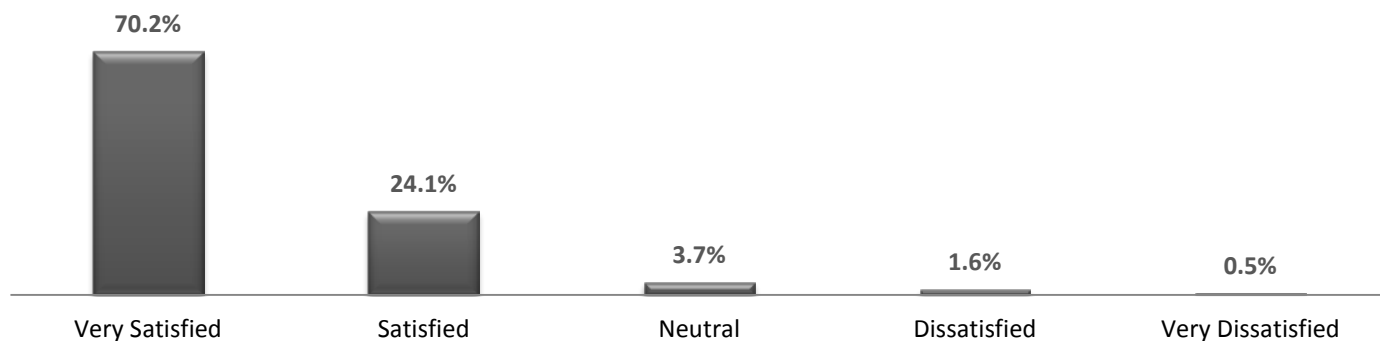

How satisfied were you with the assistance provided by MagLab facilities technical staff?

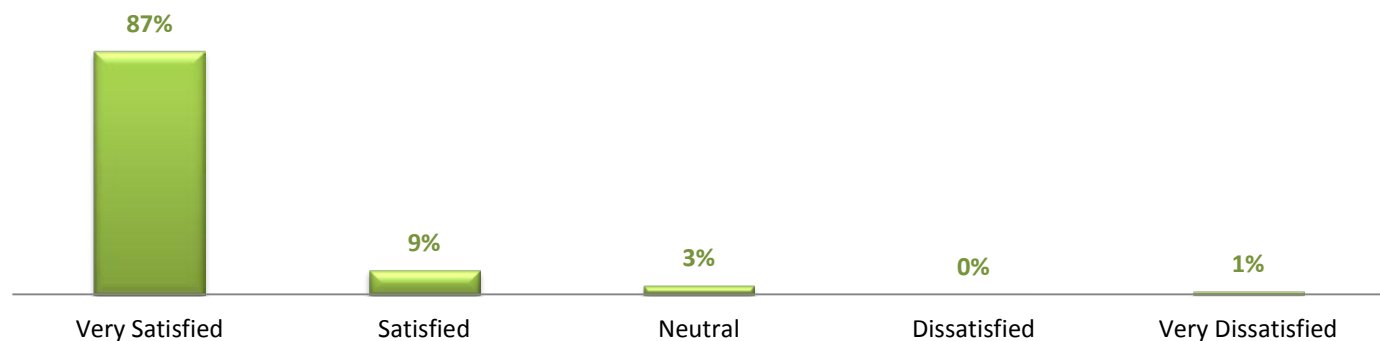

# Chapter 3 – User Facilities

How satisfied were you with the assistance provided by MagLab facilities administrative staff?

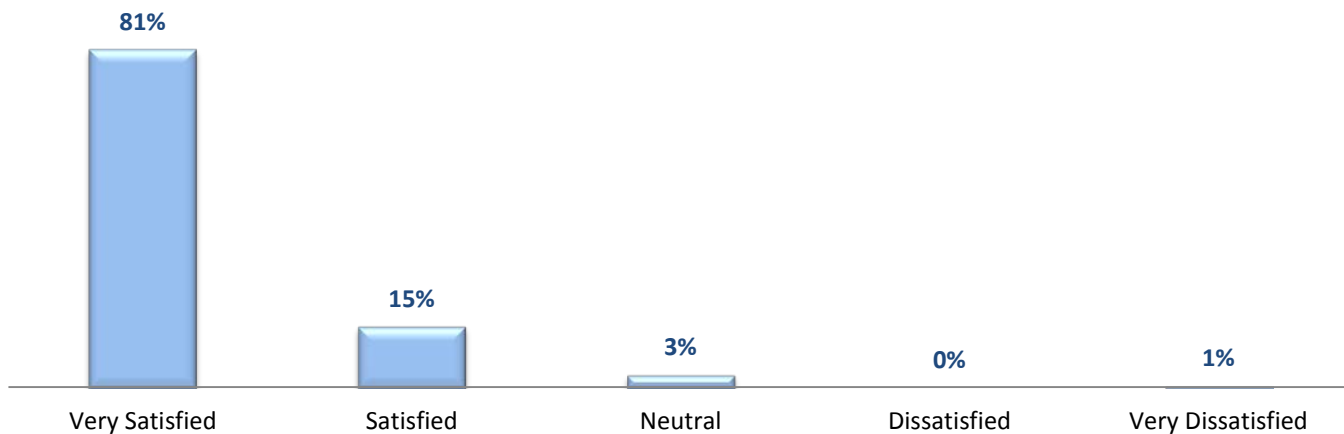

External only - As a result of your use of MagLab facilities, do you expect to ...

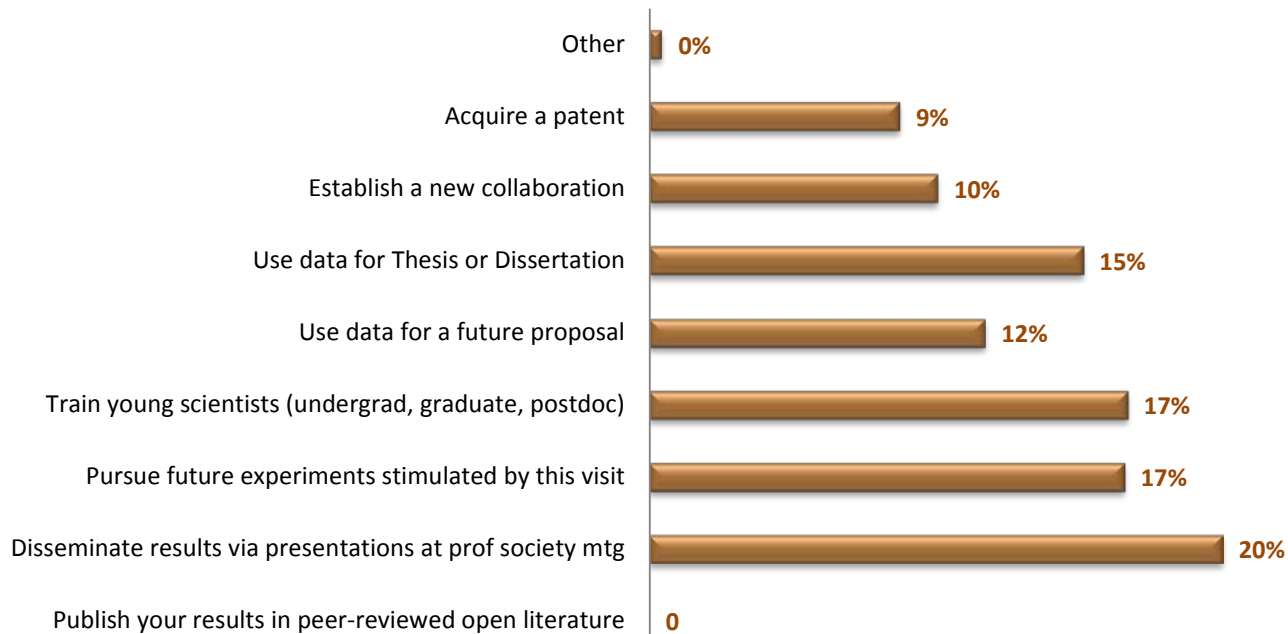

# Chapter 3 – User Facilities

AMRIS

AMRIS

## 3.6. User Facilities

### 3.6.1. Advanced Magnetic Resonance Imaging and Spectroscopy (AMRIS)

*The AMRIS facility at the University of Florida supports nuclear magnetic resonance (NMR) and magnetic resonance imaging (MRI) studies of chemical compounds, biomolecular systems, tissues, small animals, large animals, and humans. We currently offer eleven systems with different magnetic fields and configurations to users for magnetic resonance experiments. AMRIS has twelve professional staff members to assist users, maintain instrumentation, build new coils and probes, and help with administration.*

#### 3.6.1.1. Unique Aspects of Instrument Capability

AMRIS instruments offer users unique capabilities: the 750 MHz wide bore provides outstanding high-field imaging for excised tissues and small animals as well as diffusion measurements with gradient strengths up to 30T/m; the 11.1T horizontal MRI has the highest field strength MRI magnet in the world with a 400 mm bore and gradient strengths up to 1.5T/m; the 600 MHz 1.5-mm HTS cryoprobe is the most mass-sensitive NMR probe the world for  $^{13}\text{C}$  detection and is ideal for natural products research; the 5T DNP polarizer enables both fundamental studies of DNP mechanisms down to 1.2 K as well as *in vivo* metabolism measurements when coupled to either the 4.7 or 11.1T systems. These systems support a broad range of science, from natural product identification to solid-state membrane protein structure determination to cardiac studies in animals and humans to correlating neural structures at high resolution with brain function and chemistry.

#### 3.6.1.2. Facility Developments and Enhancements

The installation of a  $^{13}\text{C}$ -optimized 10 mm cryoprobe at 600 MHz in combination with the Hypersense DNP polarizer installed last year now enables real-time metabolic measurements in functioning cardiac tissue. Many projects funded as part of the BRAIN initiative are underway. We recently ordered new NMR consoles at 600 and 800 MHz to ensure high field NMR magnets offer the latest in pulse sequence capabilities and multinuclear detection. These consoles will be installed in early 2018.

#### 3.6.1.3. Major Research Activities and Discoveries

This year we saw continued research growth in our major research focus areas. The first area is in fundamental DNP studies and their application to *in vivo* metabolic studies. A second area of growth was in

supporting users pursuing quantitative studies for metabolomics and structural biology research projects. A third area of growth was in the use of *in vivo* MRI and MRS to study structure/function/chemistry in rodent models up to 17.6T. Research in these areas led to and will leverage the enhancements described in section 2. AMRIS facility users reported 64 peer-reviewed publications and 12 theses and dissertations for 2017.

#### 3.6.1.4. Facility Plans and Directions

In spite of the continued challenging budgetary climate, our users have consistently successfully pursued federal funding to support their research programs and assisted the AMRIS facility in writing proposals to upgrade instrumentation. The successful partnership of the NHMFL user program with individual investigator research grants also provides constant scientific motivation for our technology development. This year we received an NIH high end instrumentation grant to purchase the Siemens 3T MRI scanner. We also received an NIH P41 technology center grant in August. This five year grant will fund the continued development of NMR probes with world-leading sensitivity for biomolecular studies.

#### 3.6.1.5. Progress on STEM and Building User Community

In 2017, the NHMFL coordinator at the University of Florida, Elizabeth Webb, and graduate students and post-doctoral fellows working with her visited 79 classrooms in 18 schools, reaching 1,700 students as part of the NHMFL classroom outreach program in Gainesville. An additional 19 presentations were made at 4 schools reaching 195 students as part of summer programs at area schools and the afterschool science program Elizabeth runs. Additionally, AMRIS faculty and staff led eight AMRIS tours in 2017, reaching 150 high school and undergraduate students, industry

# Chapter 3 – User Facilities

## AMRIS

engineers, and a portion of the Gainesville retired community.

This year, Elizabeth also co-organized the Women in Science and Engineering (WiSE) Girls spring break camp with AMRIS engineer Malathy Elumalai. This weeklong camp brought middle school girls from Alachua County to the University of Florida to learn about a variety of different sciences, and included a tour of and hands-on activities at the AMRIS Facility.

In March, we again held our very popular RF Coil building workshop in the AMRIS Facility. Five participants came for a week to learn the physics behind MRI, RF coil theory, and how to build RF coils. As part of this workshop, a half-day training workshop on CST software was given to 20 students and post-docs, including the workshop participants.

## AMRIS

Faculty associated with the AMRIS Facility mentored three NHMFL REU students over the summer and gave periodic tours of the AMRIS Facility. This faculty consistently has ~20 undergraduate and high school students working on projects at any given time.

### 3.6.1.6. Facility Operations Schedule

The AMRIS facility operates year round, except during the last week of December when the University of Florida is shut down. Vertical instruments for ex vivo samples are scheduled 24/7, including holidays and weekends. Horizontals operate primarily 8 hr/day, 5 days/week due to the difficulty in running animal or human studies overnight. The AMRIS facility operates as an auxiliary under federal cost accounting standards. Local and NHMFL-affiliated users pay for magnet time from federally funded projects (primarily individual investigator grants); the NHMFL funds magnet time for users from outside the UF system and development projects.

***NMR & MRI Systems in the AMRIS Facility at UF in Gainesville***

<b><sup>1</sup>H Frequency</b>	<b>Field (T), Bore (mm)</b>	<b>Homogeneity</b>	<b>Measurements</b>
750 MHz	17.6, 89	1 ppb	Solution/solid state NMR and MRI
600 MHz	14.1, 52	1 ppb	NMR and microimaging
600 MHz	14.1, 52	1 ppb	Solution NMR (cryoprobe)
600 MHz	14.1, 54	1 ppb	Solution NMR (HTS cryoprobe)
500 MHz	11.7, 52	1 ppb	Solution/solid state NMR
470 MHz	11.1, 400	0.1 ppm	DNP, MRI and NMR of animals
212 MHz	5.0, 89	1 ppm	DNP polarization
200 MHz	4.7, 330	0.1 ppm	DNP, MRI, and NMR of animals
143 MHz	3.35, 52	1 ppm	DNP polarization
128 MHz	3.0, 900	0.1 ppm	MRI/S of humans, large animals
128 MHz	3.0, 900	0.1 ppm	MRI/S of humans

# Chapter 3 – User Facilities

AMRIS

AMRIS

## *In Vivo* fMRI Reveals Severely Disrupted Neural Connectivity in the Brain Following Exposure to Dangerous 'Bath Salt' Drug

Luis M. Colon-Perez, Adriaan W. Bruijnzeel, Barry Setlow, Marcelo Febo

Departments of Psychiatry and Neuroscience, McKnight Brain Institute, University of Florida, Gainesville

Funding Grants: G.S. Boebinger (NSF DMR-1157490); M. Febo (NIH DA038009)

Designer synthetic drugs with potent addictive properties have emerged in recent years as a public health hazard. In particular, synthetic cathinones, also known as 'bath salt' drugs, have been shown to cause adverse effects on social, emotional and cognitive behavior. Based on the psychosis-like and hallucinatory effects of one of the most dangerous of these bath salt drugs, 3,4-methylenedioxypyrovalerone (MDPV), we hypothesized that it would elicit disruptive effects on the brain's resting-state neural networks.

Male rats were imaged following administration of a single dose of MDPV or saline. Dose levels were 0.3, 1.0, or 3.0mg of MDPV per kg body weight). Resting state brain fMRI, consisting of blood oxygenation level dependent (BOLD) images, were acquired at 4.7 Tesla.

Detailed functional neural connectivity analysis across 150 regions of interest in the rat brain revealed extensive disruption of connectivity, particularly between frontal cortical and striatal areas. These results evidence a novel in vivo mechanism for the deleterious effects of MDPV as well as a biomarker that can be used to test the efficacy of potential treatments for the psychosis and longer term negative behavioral effects of these drugs. Finally, this MagLab research advances the use of functional and structural neural connectivity analysis of drug addiction in animal models.

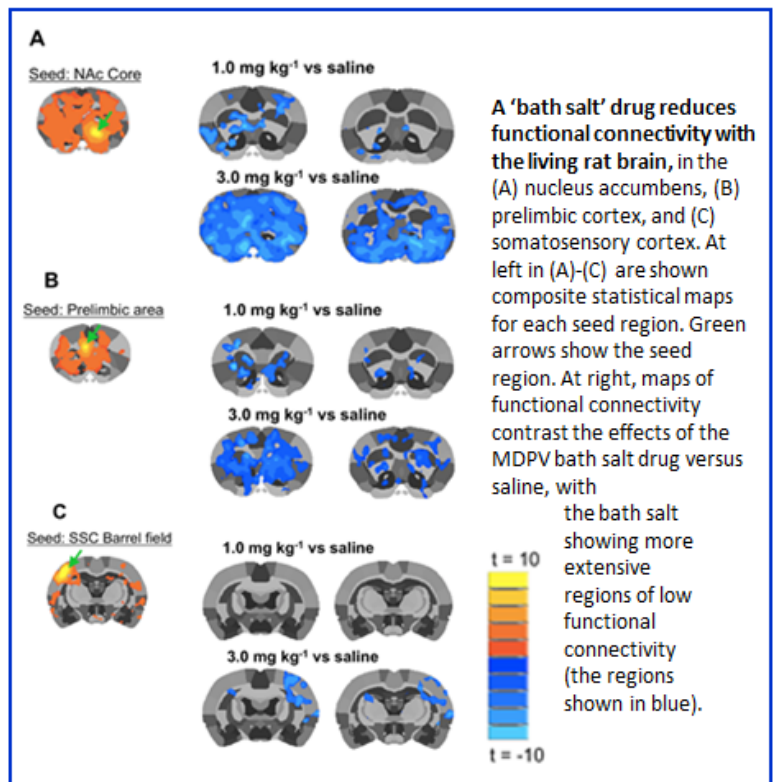

**Facilities:** AMRIS Facility, 4.7 T

**Citation:** Colon-Perez, L.M.; Tran, K.; Thompson, K.; Pace, M.C.; Blum, K.; Goldberger, B.A.; Gold, M.S.; Bruijnzeel, A.W.; Setlow, B. and Febo, M., *The Psychoactive Designer Drug and Bath Salt Constituent MDPV Causes Widespread Disruption of Brain Functional Connectivity.*, *Neuropsychopharmacology*, **4** (9), 2352-65 (2016)

# Chapter 3 – User Facilities

DC Field

DC Field

## 3.6.2. DC Field Facility

The DC Field Facility in Tallahassee serves its large and diverse user community by providing continuously variable magnetic fields in a range and quality unmatched anywhere in the world. The DC Field user community is made up of undergraduate students, graduate students, postdocs and senior investigators from around the country and the world. State-of-the-art instrumentation is developed and coupled to these magnets through the efforts of our expert scientific and technical staff. The users of the DC Field Facility are supported throughout their visit by the scientific, technical, and administrative staff to ensure that their visit is as productive as possible. The interaction between the NHMFL scientific and technical staff with the students, postdocs, and senior investigators who come to the DC Field Facility to perform their research results in a continuous mix of scientific ideas and advanced techniques that are passed both to and from users.

### 3.6.2.1. Unique Aspects of Instrumentation Capability

**Table 1:** DC Field Magnets

FLORIDA-BITTER and HYBRID MAGNETS		
Field, Bore, (Homogeneity)	Power (MW)	Supported Research
45T, 32 mm, (25 ppm/mm)	30.4	Magneto-optics – ultra-violet through far infrared; Magnetization; Specific heat; Transport – DC to microwaves; Magnetostriction; High Pressure; Temperatures from 30 mK to 1500 K; Dependence of optical and transport properties on field, orientation, etc.; Materials processing; Wire, cable, and coil testing; NMR, EMR, and sub/ millimeter wave spectroscopy.
41T, 32 mm, (25 ppm/mm)	32	
36T, 40 mm, (1 ppm/mm) <sup>2</sup>	14	
35T, 32 mm (x2)	19.2	
31T, 32 mm to 50 mm <sup>1</sup> (x2)	18.4	
25T, 32 mm bore (with optical access ports) <sup>3</sup>	27	
SUPERCONDUCTING MAGNETS		
Field (T), Bore (mm)	Sample Temperature	Supported Research
18/20T, 52 mm	20 mK – 1 K	Magneto-optics – ultra-violet through far infrared; Magnetization; Specific heat; Transport – DC to microwaves; Magnetostriction; High pressure; Temperatures from 20 mK to 300 K; Dependence of optical and transport properties on field, orientation, etc.; Low to medium resolution NMR, EMR, and sub/millimeter wave spectroscopy.
18/20T, 52 mm	0.3 K – 300 K	
17.5T, 47 mm	4 K – 300 K	
10T, 34 mm <sup>3</sup>	0.3 K – 300 K	

<sup>1</sup> A coil for modulating the magnetic field and a coil for superimposing a gradient on the center portion of the main field are wound on 32 mm bore tubes.

<sup>2</sup> Higher homogeneity magnet for magnetic resonance measurements.

<sup>3</sup> Optical ports at field center with 4 ports each 11.4° vertical x 45° horizontal taken off of a 5mm sample space

**Table 1** lists the magnets in the DC Field Facility. The NHMFL leads the world in available continuous magnetic field strength, number of high field DC magnets available to users and accessibility for scientific research. The 45T hybrid magnet is the highest field DC magnet in the world, which is reflected in the number of proposals from Principle Investigators located overseas. The recently tested 41T resistive magnet is the highest field resistive magnet in the world. The 36T Series Con-

nected hybrid magnet features two configurations: 40mm bore, with 1 ppm homogeneity for chem/bio NMR experiments and a 48 mm bore with 20 ppm homogeneity for condensed matter physics experiments in a top-loading cryogenic system. The 35T, 32 mm bore and 31T, 50 mm bore magnets are coupled to top loading cryogenic systems that have impressive performance, flexibility, and ease of use. The 25T Split-Helix magnet is the highest field direct optical access / scat-

# Chapter 3 – User Facilities

## DC Field

tering magnet in the world. With 4 optical ports located at field center each having a 11.4° vertical x 45° horizontal taken off of a 5mm opening, the ability to perform ultrafast, time resolved, and x-ray scattering experiments are now a reality at high magnetic fields.

### 3.6.2.2. Facility Developments and Enhancements 32T All Superconducting Magnet Reaches Full Field



**Figure 1:** 32T superconducting magnet in its test stand.

On December 12, 2017 the 32T all superconducting magnet reached full field and passed a rigorous testing protocol with flying colors. This achievement is a culmination of 8 years of intensive work by MagLab engineers and scientists to create the highest field, superconducting magnet ever constructed. This accomplishment represents the beginning of a new era in high-magnetic field research at the MagLab by allowing scientists to perform experiments at magnetic fields that had previously only been accessible in resistive magnets. The combination of high peak field, ability to remain at high fields for long periods of time and quiet electrical sample environment give scientists a unique opportunity to explore the quantum realm with greater depth than before.

### Completion of the mK Facility Expansion

Construction was completed in 2017 on the 1,600 ft<sup>2</sup> expansion to the mK facility which will provide a permanent home for the 32T superconducting magnet where it will become a user magnet. The building features two magnet pits with the second pit slated for

## DC Field

a future HTS magnet to be installed as well as separate star grounds located under each pit to provide clean grounding for user instrumentation. The walls and ceiling include a layer of copper to reduce the ambient RF levels from external sources. This new addition will allow users to take full advantage of the 32T magnet's scientific capabilities in an environment with a low EMF background. A variable temperature cryostat for the magnet is already on-site and a dilution refrigerator has been ordered with delivery anticipated in late summer 2018. Installation of the 32T magnet will begin in spring 2018 followed by commissioning tests in the summer.



**Figure 2:** Interior view of the mK facility expansion.

### Construction of a Short Stay Facility for Users

In 2017, the FSU Vice President for Research, Gary Ostrander, announced that FSU was providing funding to construct a short stay facility for users that would be attached to the MagLab. The two-story building has ~ 3,800 ft<sup>2</sup> and can accommodate up to twelve guests. The building features an enclosed connection to the MagLab, a large, well-equipped kitchen/common area as well as a collaborative space. The design was completed in late 2017, and construction will begin in early 2018 with completion planned for January 2019.

# Chapter 3 – User Facilities

DC Field

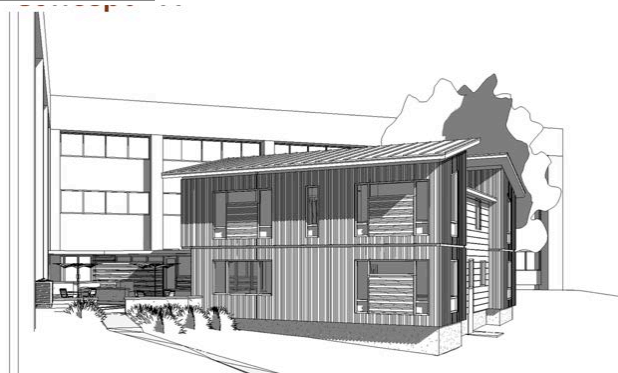

**Figure 3:** Street view of the Short Stay Facility with the MagLab in the background.

## *36T Series Connected Hybrid (SCH) Achieves Design Homogeneity and Drift Specifications and Begins Commissioning Tests.*

In early 2017, the field compensation system for the SCH achieved a 1 ppm homogeneity over a 10 mm DSV. The NMR group then went through a series of commissioning tests to validate the performance of the spectrometer, probes, and ancillary equipment. Work was also done to quantify the effect of cooling water temperature drift and power supply component temperature drift on the temporal stability of the magnetic field. **Figure 4** shows the dramatic effect of the NMR lock on the temporal stability of the field.

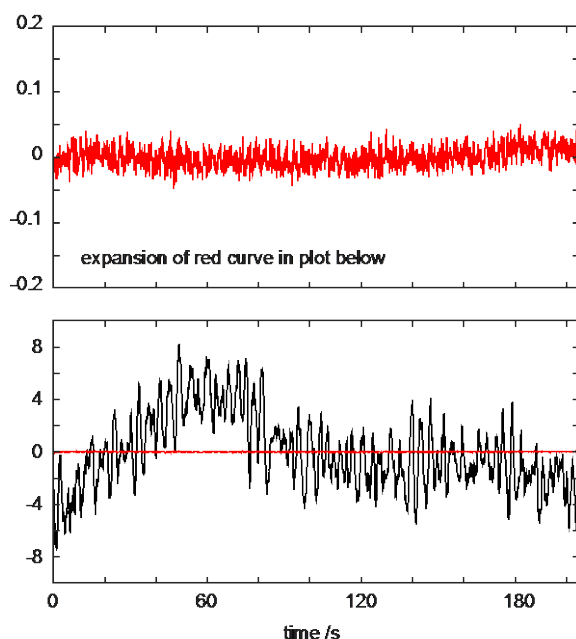

## *Performance of the 41T Resistive Magnet (Project 11) Exceeds Design Field*

On August 21<sup>st</sup>, the newest resistive magnet in the DC Field Facility produced 41.4T using 32 MW of power exceeding the design specification of 41T. Shown in **Figure 5** below, the 41T resistive magnet located in cell 6 employs six nested coils with an outer diameter of 1 meter and a bore size of 32 mm. For reference the 35T, 19 MW resistive magnets employ three nested coils with an outer diameter of 0.6 meters and a bore size of 32 mm. This magnet allows researchers to access intense magnetic fields that had previously only been accessible using hybrid magnets. The ability to rapidly sweep magnetic fields and easily reverse polarity will give users the speed and flexibility to explore the fascinating range of properties exhibited by quantum materials. The magnet cell is now being outfitted with the personnel platform and a custom high-performance vibration isolation platform for the cryostat which has been ordered and will arrive in early summer.



**Figure 5:** 41T resistive magnet located in cell 6.

**Figure 4 (left):** Lower panel shows native temporal stability of the magnet without field stabilization system (black trace) and with the stabilization system on (red trace). The upper panel is an expanded view of the trace with the stability system operating. The Y-axis on both plots is in ppm.



# Chapter 3 – User Facilities

DC Field

DC Field

## *Installation of New Magnet Cooling Water Heat Exchanger and Filters*

During the DC Field Facilities annual maintenance shutdown one of the two magnet cooling water heat exchangers was replaced and new, low-pressure differential filters were installed. The new heat exchanger shown in **Figure 6**, has the ability to exchange up to 36 MW of heat between the ultra-clean magnet cooling water loop and the chiller circulation loop. It also enables more efficient utilization of the cooling capacity of the chillers and storage tanks by possessing a significantly larger envelope of operational flow and temperature parameters. The new filters that are installed at the entrance to the heat exchangers have a



significantly lower pressure drop across them improving the performance of the magnet cooling water system as a whole.

**Figure 6:** New magnet cooling water heat exchanger being delivered outside the DC Field Facility plant.

### 3.6.2.3. Major Research Activities and Discoveries

DC Field Facility users engaged in research across a spectrum of materials, phase space, and scientific directions in 2017 with quantum materials by far being the largest area of research in the DC Field magnets. The group of Malte Grosche from Cambridge University studied a *Mott insulator ( $\text{NiS}_2$ ) under the influence of high pressures and magnetic fields* and observed that at a critical pressure the previously gridlocked electrons become mobile, converting the insulator into a metal. Further, they also observed that the electron-electron interaction increases rapidly as the critical pressure is approached from the metallic side, becoming divergent at the critical pressure.

*The discovery of an exciton (electron-hole pair) condensate in double bilayer graphene devices* was

made independently by groups from Columbia University and Harvard University. The devices consisted of two double layer graphene devices separated by hBN insulating layer. One side (drive) of the device is driven with current, and in the non-driven (drag) side, a quantized hall voltage is observed indicating that an electron-hole pair (exciton) is formed across the hBN boundary separating the two double layer devices. In the quantum Hall regime at high magnetic fields and low temperatures, the excitons formed a Bose-Einstein Condensate (BEC) phase as the excitons are bosons. A characteristic of the BEC phase results in the dissipationless flow of electrons in the longitudinal resistivity providing telltale evidence that the state is an exciton condensate.

*Dirac and Weyl semimetals* are being studied by a number of user groups at the MagLab, and in particular a group from the University of New Orleans under the direction of Z.Q. Mao investigated  $\text{Sr}_{1-y}\text{Mn}_{1-z}\text{Sb}_2$  ( $y, z < 0.1$ ) in both DC and pulsed magnetic fields. Their data shows that the material is a *magnetic topological semimetal*, hinting at a unique opportunity to further investigate relativistic fermions interacting with spontaneously broken time reversal symmetry.

### 6.3.2.4. Facility Plans and Directions

*Construction of the user short stay facility* will begin in 2018 with completion projected for January 2019, giving users the ability to stay on-site during their magnet time reducing the need for renting a car and wearily driving back to a hotel at 3:00 a.m. During the building process, MagLab staff will be working with vendors to develop and implement the reservation, payment, and check-in/out systems with the goal of making the process of staying in the facility straightforward and efficient.

*32T magnet installation and commissioning* will occur in 2018 with user operations projected to begin shortly after. Design, fabrication, and installation of the infrastructure needed to accept the magnet in the pit is being done in parallel with the initial set of magnet tests that took place in cell 4 and we anticipate cooling down the magnet in April. The top-loading dilution refrigerator and associated equipment is scheduled for delivery in late summer.

# Chapter 3 – User Facilities

DC Field

DC Field

*Installation of cryostat vibration isolation platform for the 41T magnet* is in progress and will be completed prior to arrival of the top loading cryostat this summer.

MagLab staff partnered with Newport Research to design and fabricate the platform, which is based on the successful design approach that Newport used for the optical tables used with the 25T split-helix magnet. **Figure 7** shows a solid model of the system with the personnel platform greyed out.

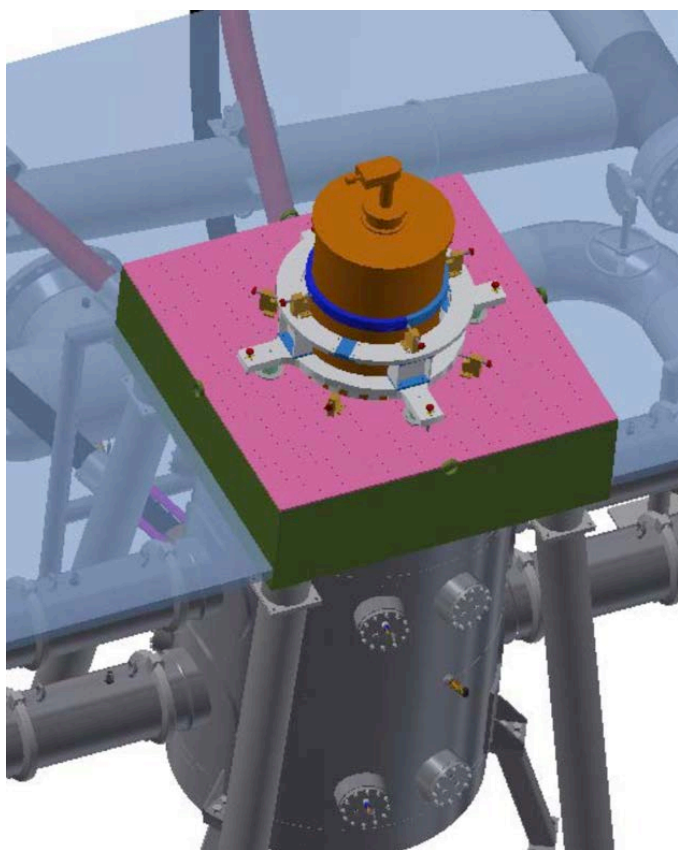

**Figure 7:** 41T cryostat vibration isolation platform.

*Installation of a new water treatment system for the resistive magnet cooling loop is planned for 2018.* The current system was original to the construction of the MagLab in 1993 and is nearing the end of its service life. The water treatment system removes metal ions that are shed from the magnet coils during operation so that the cooling water is maintained at a high resistivity. The current system has a single resin bed and

the regeneration process takes several weeks during which time the water-cooled magnets cannot run. The new system will have two resin beds allowing operation of the magnets using one bed while the other is regenerating.

### 3.6.2.5. Outreach to Generate New Proposals-Progress on STEM and Building the User Community

The DC Field Facility continued to see heavy user demand in 2017 as shown by the usage tables in **Appendix I**. In spite of this oversubscription, however, the DC Field Facility has continued to make bringing new principal investigators (PI's) into the NHMFL a priority. We continue our efforts to reach out wherever possible in order to expand our user program and enable PIs from backgrounds underrepresented in the scientific community. In particular, the NHMFL sponsored a booth at the 2017 APS March Meeting in New Orleans to advertise the capabilities and opportunities offered by the MagLab. The booth is staffed by NHMFL scientists & staff who explain the spectrum of research possibilities and support available at the NHMFL. In addition our DC Field Facility user support scientists regularly travel to conferences to present their results that showcase the capabilities of the Laboratory and to recruit new users.

In 2017, the DC Field Facility continued to attract new researchers. **Appendix I, Table 8**, shows the DC Field Facility attracted **26 new PI's in 2017**. This is in addition to the 24 new PIs reported last year (2016) and 18 in 2015. These new PI's hail from a broad cross-section of institutions such as Bruker Inc., Federal University of Pernambuco, Cornell University, and the University of Geneva.

The DC Field Facility also hosted the **2017 NHMFL User Summer School** that attracted 22 graduate students and postdoc attendees (**Figure 8**). It is a five-day series of lectures and practical exercises in experimental condensed matter physics techniques developed and taught by members of the MagLab scientific staff from the 3 sites. It has proven to be an excellent vehicle for communicating valuable experimental knowledge to the next generation of scientists from the enormous trove of experience encompassed by the MagLab scientific staff. The Summer School is an annual event and will be presented again in 2018 and feedback from

# Chapter 3 – User Facilities

## DC Field

participants and their advisors continues to be very positive.



**Figure 6:** 2017 NHMFL Summer School Participants

### 3.6.2.6. Facility Operations Schedule

At the heart of the DC Field Facility are the four 14 MW, low-noise DC power supplies. Each 20 MW resistive magnet requires two power supplies to run, the 45T hybrid magnet requires three power supplies, and the 36T Series Connected Hybrid requires one power supply. Thus the DC Field Facility operates in the following manner: in a given week there can be four resistive magnets + three superconducting magnets operating or the 45T hybrid, series connected hybrid, two resistive magnets, and three superconducting magnets. The

## DC Field

powered DC resistive and hybrid magnets operated for 45 weeks in 2017 with a 6 week shutdown for infrastructure maintenance from November 13, 2017 to December 22, 2017 and a 1 week shutdown period for the University mandated holiday break from December 25, 2017 to January 2, 2018. The three superconducting magnets operated for 48 weeks out of the year with staggered maintenance periods as required. The hourly operation schedule for the resistive and hybrid magnets is as follows: 7 hours/day on Monday and 21 hours/day Tuesday-Friday. The superconducting magnets operate 24 hours/day, 7 days/week. The effects of Hurricane Irma resulted in a one-week shutdown of the DC Field Facility.

# Chapter 3 – User Facilities

DC Field

DC Field

## Pressure converts an insulator into a metal with enhanced electronic mass

H. Chang<sup>1</sup>, S. Friedemann<sup>1,2</sup>, A. Grockowiak<sup>3</sup>, W. Coniglio<sup>3</sup>, K. Semeniuk<sup>1</sup>, J. Baglo<sup>1</sup>, S. Tozer<sup>3</sup>, F. M. Grosche<sup>1</sup>

1. University of Cambridge, UK; 2. University of Bristol, UK; 3. NHMFL Tallahassee

Funding Grants: G.S. Boebinger (NSF DMR-1157490); Chang, Friedemann, Semeniuk, Baglo and Grosche (EPSRC EP/K012894/1); Friedemann (EU Marie Curie fellowship 271982)

In Mott insulators, electrons are locked into position by their mutual Coulomb repulsions. Varying the lattice density by applied pressure makes it possible to metallize a Mott insulator and study the resulting correlated metallic state, a state in which the formerly grid-locked electrons have become mobile. Understanding correlated metals on the brink of Mott localization is of general interest, as this is the system that hosts high temperature superconductivity in the cuprates. Foremost among scientific questions about the high-pressure metallic state is the fate of the electronic Fermi surface and the associated charge carrier mass.

These key properties have been probed by ultra-sensitive quantum oscillation measurements under pressure in high-purity samples of the Mott insulator,  $\text{NiS}_2$ . The work exploited pioneering high-pressure anvil cell techniques, combined with radio-frequency contact-free resistivity measurements. Data was collected at pressures up to 97kbar in magnetic fields up to 35T, and at temperatures down to less than 0.1K.

Our data demonstrate that the charge carrier density remains constant, although the charge carriers increase their mass dramatically upon approaching the Mott insulating state from the metallic side. These studies open the door to high-pressure electronic structure determination in a host of other correlated systems of long-standing scientific interest.

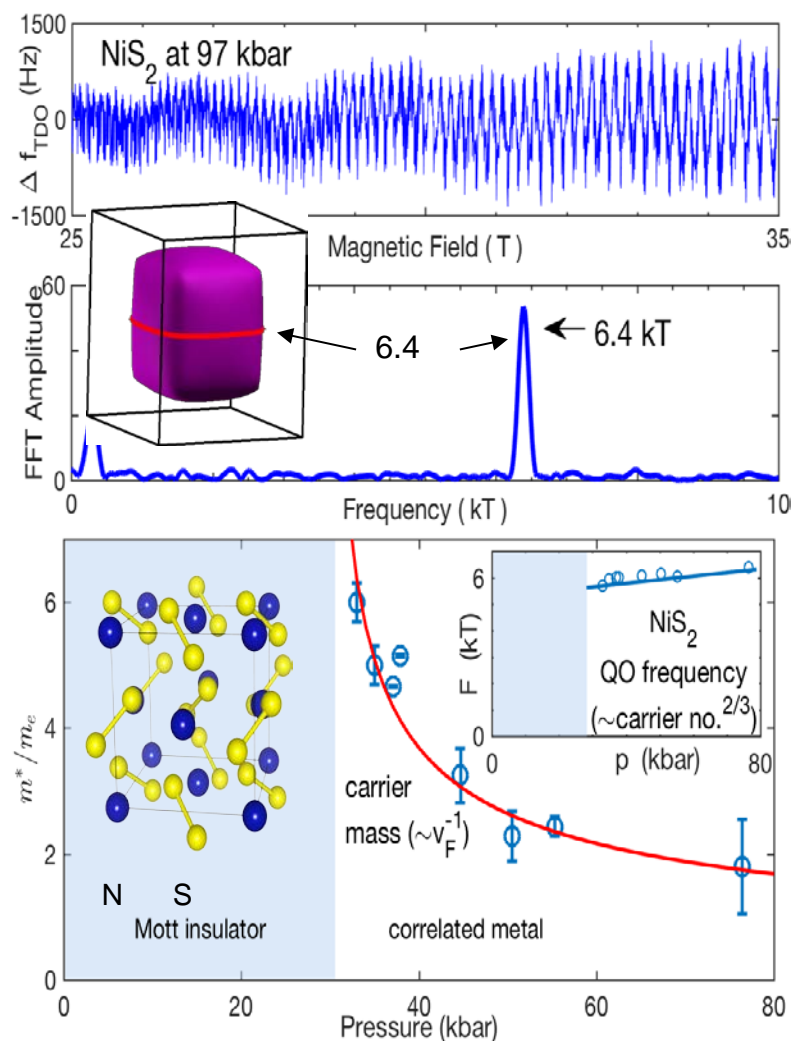

**Top:** Quantum oscillations in  $\text{NiS}_2$  that appear at pressures above the Mott transition that is at  $\sim 30$  kbar. **Bottom:** Diverging carrier mass observed near the transition despite the pressure-independent Fermi surface size (inset).

**Facilities:** DC Facility,<sup>3</sup> He and dilution refrigerators, high pressure and rf-electronics facilities at the MagLab in Tallahassee.  
**Citation:** Large Fermi surface of heavy electrons at the border of Mott insulating State in  $\text{NiS}_2$ , S. Friedemann, H. Chang, M. B. Gamza, P. Reiss, X. Chen, P. Alireza, W. A. Coniglio, D. Graf, S. Tozer, and F. M. Grosche, **Scientific Reports** 6, 416 (2016).

# Chapter 3 – User Facilities

DC Field

DC Field

## Two Observations of an Exciton Condensate in Double Bilayer Graphene

Collaboration A: J.I.A. Li<sup>1</sup>, T. Taniguchi<sup>2</sup>, K. Watanabe<sup>2</sup>, J. Hone<sup>1</sup>, C.R. Dean<sup>1</sup>, Columbia University; 2. National Institute for Materials Science, Japan. Collaboration B: X. Liu<sup>3</sup>, K. Watanabe<sup>4</sup>, T. Taniguchi<sup>4</sup>, B. Halperin<sup>3</sup>, P. Kim<sup>3</sup>, 3. Harvard University; 4. National Institute for Materials Science, Japan.  
 Funding Grants: G.S. Boebinger (NSF DMR-1157490); C.R. Dean (NSF DMR-1507788 & Packard Foundation); P. Kim (DOE DE-SE0012260 & Moore Foundation GBMF4543)

An exciton is created when an electron and a hole become bound together through the coulomb interaction. Recently, two independent teams used MagLab facilities to observe long-lived excitons in new double-layer electron systems, realized by alternating bi-layer graphene and hexagonal boron nitride (BN) sheets. Under a high magnetic field, electron-like and hole-like quasiparticles emerge from partially filled Landau levels in each graphene sheet. These can bind into long-lived excitons by Coulomb attraction across the middle layer of BN. In the quantum Hall regime at high magnetic fields and low temperatures, the excitons, which are bosons, were observed to form a Bose-Einstein Condensate (BEC) phase.

Exciton pairs are observed by driving a current through only one of the graphene layers (the “drive” layer), which produces a sizeable and nearly quantized Hall voltage in the other (“drag”) layer at low temperatures (blue traces at 300mK). Here, the quantum Hall resistance,  $R_{xy}$ , becomes equal to  $h/e^2$  in both the drive and drag layers. The quantization of these two values of the Hall resistance - coupled with the observation of the longitudinal resistivity in the drag layer,  $R_{xx}(\text{drag})$ , dropping to zero - provides strong evidence for the transition to an exciton condensate.

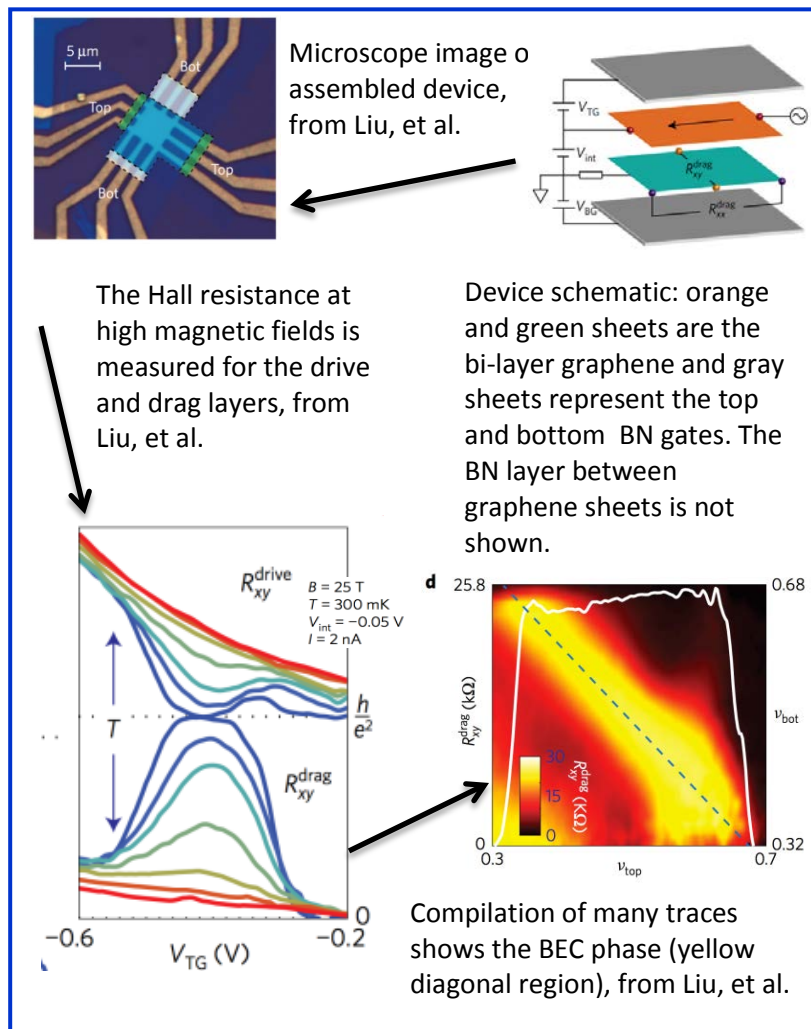

**Facilities:** DC Field Facility, Cell 9: 31 T resistive magnet; SCM 1: 20 T SC magnet with dilution refrigerator.

**Citations:** **Collaboration A:** *Excitonic superfluid phase in double bilayer graphene*, J.I.A Li, T. Taniguchi, K. Watanabe, J. Hone and C.R. Dean, **Nature Physics**, doi:10.1038/nphys4140. **Collaboration B:** *Quantum Hall drag of exciton condensate in graphene*, Xiaomeng Liu, Kenji Watanabe, Takashi Taniguchi, Bertrand Halperin and Philip Kim, **Nature Physics**, doi:10.1038/nphys4116.

# Chapter 3 – User Facilities

EMR

EMR

## 6.3.3. EMR Facility

*Electron Magnetic Resonance (EMR) covers a variety of magnetic resonance techniques associated with the electron. The most widely employed is Electron Paramagnetic/Spin Resonance (EPR/ESR), which can be performed on anything that contains unpaired electron spins. EPR/ESR has thus proven to be an indispensable tool in a large range of applications in physics, materials science, chemistry, and biology, including studies of impurity states, molecular clusters, molecular magnets; antiferromagnetic/ferromagnetic compounds in bulk, as well as thin films and nanoparticles; natural or induced radicals, optically excited paramagnetic states, electron spin-based quantum information devices; transition-metal based catalysts; and for structural and dynamical studies of metallo-proteins, spin-labeled proteins, and other complex bio-molecules and their synthetic models.*

### 6.3.3.1. Unique Aspects of Instrumentation Capability

The EMR facility at the NHMFL offers users several home-built, high-field, and multi-high-frequency instruments covering the continuous frequency range from 9 GHz to ~1 THz, with additional frequencies up to 2.5 THz using a molecular gas laser. Several transmission probes are available for continuous-wave (CW) measurements, which are compatible with a range of magnets at the Lab, including the highest field 45T hybrid. Some of the probes can be configured with resonant cavities, providing enhanced sensitivity as well as options for in-situ rotation of single-crystal samples in the magnetic field, and the simultaneous application of pressure (up to ~3 GPa). Quasi-optical (QO) reflection spectrometers are also available in combination with high-resolution 12 and 17T superconducting magnet systems; a simple QO spectrometer has also been developed for use in the resistive and hybrid magnets (up to 45T). EMR staff members can assist users in the DC field facility using broadband tunable homodyne and heterodyne spectrometers as well.

In addition to CW capabilities, the NHMFL EMR group boasts the highest frequency pulsed EPR spectrometer in the world, operating at 120, 240, and 336 GHz (and now 395 GHz) with <100 ns time resolution. A new quasi-optical 94 GHz spectrometer (HiPER) with 1 ns time resolution was recently upgraded for high power (1 kW) operation, becoming available to users at the end of 2015. A commercial Bruker Elexsys 680 operating at 9/94 GHz (X-/W-band) is also available upon request. This unique combination of CW and pulsed instruments may be used for a large range of applications in addition to EPR, including the study of optical conductivity and electron cyclotron resonance.

### 6.3.3.2. Facility Developments and Enhancements

A number of upgrades and improvements to the EMR instruments were implemented during 2017. A completely new multiplier chain was acquired for the workhorse homodyne spectrometer, providing wider frequency coverage, enhanced sensitivity/dynamic-range, and greater flexibility when using the sources in the DC facility, i.e. it is now possible to use these sources for high-field experiments in the DC facility without completely shutting down operations on the homodyne transmission spectrometer. Another important feature of the new multiplier chain is that it was specified for frequency bands that fill several gaps in coverage of the original source. Consequently, the two sources together provide comprehensive coverage from about 25 to 700 GHz.

In addition to the new multiplier chain, a narrow-band source operating at 395 GHz was acquired as part of the group's efforts to develop Dynamic Nuclear Polarization (DNP) enhanced NMR capabilities at 600 MHz. The main application of this new source is for in-situ EPR on the DNP instrument. However, the source can be employed on almost any other magnet system within the EMR facility (and the DC facility), meaning that it now provides a robust option for many other applications, including pulsed EPR on the 12.5T heterodyne spectrometer. A new local oscillator operating at 215 and 230 GHz was also acquired for the Heterodyne Quasioptical Spectrometer, allowing for higher sensitivity and full quadrature detection in pulsed mode.

A 1 mW 950 GHz source and mixer-detector was acquired as part of the EMR group's efforts to develop high-resolution EPR capabilities in the new Series Connected Hybrid magnet (anticipated commissioning in 2018). This source is moderately

# Chapter 3 – User Facilities

## EMR

tunable (~920 to 980 GHz) and can also be used in essentially any other EMR/DC-facility user magnet. A newly acquired Vector Network Analyzer serves as a tunable frequency source for this  $\times 72$  multiplication chain. Moreover, it is also possible to operate the source at ~315 GHz ( $\times 24$  multiplication) by removing a tripler from the chain.

As noted in last year's report, the possibility of Arbitrary Waveform Generation (AWG) was tested on HiPER, thanks to the loan of a device from the group of Robert Griffin at MIT. That groundbreaking work has now been submitted for publication (to *J. Phys. Chem. Lett.*), along with several other recent user-driven multi-dimensional pulsed EPR studies involving HiPER (see Wang et al., *Chem. Comm.* 2018, <https://doi.org/10.1039/C7CC09765D>). As part of the ongoing efforts to develop state-of-the-art pulsed W-band EPR capabilities, a dedicated AWG (Keysight Technologies) was acquired and integrated on HiPER during the past year. We plan to hire a HiPER postdoc during 2018 to drive these capabilities forward.

The DNP efforts at 395 GHz are now part of a fully-fledged solid-state MAS-DNP enhanced NMR user program (see NMR section of this report). Meanwhile, major breakthroughs have been achieved as part of our efforts to develop a solution state Overhauser DNP capability at 600 MHz, including achieving an enhancement factor of 41 for  $^{13}\text{CCl}_4$  in d-pentane with a 10 mM solution of the radical TEMPO. Meanwhile, initial results obtained with the spectrometer have been reported in the *Journal of Magnetic Resonance* (enhancement of 160 for  $^{31}\text{P}$ , see <https://doi.org/10.1016/j.jmr.2018.01.015>).

### 6.3.3.3. Major Research Activities and Discoveries

A large number of research groups and projects were accommodated by the EMR program in 2017, resulting in the submission of 49 research reports (47 to EMR and 2 by EMR users submitted to the DC facility). In addition, 37 peer-reviewed journal articles were reported by our users, as well as numerous presentations at conferences. Many publications appeared in high-impact journals including: *PNAS* (1); *Chemical Science* (2); *Physical Review Letters* (1); *Physical Review B* (2); *Inorganic Chemistry* (13); *Inorganic Chemistry Frontiers* (1); *Journal of Physical Chemistry* (6); and *Dalton Transactions* (1). Projects in

## EMR

the facility spanned a range of disciplines, from applied materials research to studies of proteins; see also highlights below.

### 6.3.3.4. Facility Plans and Directions

The EMR program will direct extensive resources towards the development of a high-resolution EPR capability in the Series Connected Hybrid magnet during 2018. We anticipate this new capability being tested during the last quarter of the year. These development efforts are being spearheaded by a new postdoc in the group, Joscha Nehrkorn, in collaboration with the EMR Engineer, Bianca Trociewitz. The new capability is expected to enable measurements in the frequency range from ~900 GHz to 1 THz, in fields up to 36T, with <10 ppm resolution.

Another area currently under development involves the use of field-modulated Fourier-transform infrared measurements. This work, which is being carried out collaboratively with Mykhaylo Ozerov in the DC field facility, will allow users to probe much higher frequency magnetic excitations associated with crystal field splittings and first-order spin orbit coupling.

### 6.3.3.5. Outreach to Generate New Proposals-Progress on STEM and Building User Community

The total number of proposals that received magnet time during 2017 was 61, of which 16 were from first time users, meaning that 26% of our users were new to the program. Meanwhile, the EMR program assisted 165 individual researchers in 2017, of which nearly a quarter of those reporting were female (22%), and 10% minority. In an effort to attract new users, the EMR group continues to provide up to \$500 in financial support to first time visitors to the Lab (\$1,000 for overseas users). The EMR group also continues to maintain tremendous diversity among its own students and staff: 41% are female and 14% minority.

Members of the EMR group continue to make aggressive efforts to advertise the facility at regional, national, and international workshops and conferences, as well as via seminars at universities around the globe (the EMR Director gave 13 such presentations in 2017). These efforts included attending and presenting at conferences outside of their own immediate research areas. In 2017, the EMR Director Chaired the 46<sup>th</sup>

# Chapter 3 – User Facilities

## EMR

Southeastern Magnetic Resonance Conference, which was held in Tallahassee in October. This hugely successful conference was attended by many EMR users (see <https://nationalmaglab.org/semrc/>). The group also organized or participated in focused sessions/symposia at other major conferences and provided financial support in the form of student travel grants for the two main EPR conferences in the US – the Southeastern Magnetic Resonance Conference (see above) and the Rocky Mountain Conference on Magnetic Resonance. In 2018, the EMR Director will Chair the Magnetism portion of the American Physical Society March Meeting (~1,000 abstracts, or 10% of the conference), and is organizing a Symposium at the International Conference on Coordination Chemistry focusing on the application of Modern EPR Methods. Finally, the EMR group has participated in several outreach activities, including the mentorship of undergraduate students and local high-school interns.

### 6.3.3.6. Facility Operations Schedule

The most heavily used instrument in the program continues to be the 17T homodyne transmission spectrometer. This instrument has reached a point where it is significantly over-subscribed; it continues to be booked many months out, with users running 7 days per week, 24 hours per day. The spectrometer was available for all of 2017, with the exception of a few days due to the installation and testing of new sources. The usage (including tests/calibration) during 2017 was 311 days, implying that it was in use on every single weekday, as well as on >60 weekend days and/or holidays.

The 12T heterodyne/pulsed instrument was also available for all of 2017. This spectrometer is not

## EMR

straightforward to use, requiring constant oversight by the EMR staff member (van Tol) responsible for the instrument. Consequently, users are not usually scheduled when this staff member is traveling. 177 days of usage were reported in 2017, constituting ~70% of the available working days (not including weekends and holidays).

The Bruker E680 spectrometer was also over-subscribed in 2017, with total usage of 288 days. The instrument is shared between the FSU Biology Department and the EMR user program. Only 30% of the machine time was originally designated for the MagLab user program. In 2017, due to high demand from users, 79% of its usage (including holidays and weekends, i.e., 365 days total) was allocated for user operations.

A total of 238 days were logged on the new high-power pulsed EPR spectrometer, HiPER, meaning that it was operational essentially every single week day. The number of days allocated to external users is down slightly from 2016 (~150 versus ~200 in 2016) due to the departure of a key member of the EMR staff, Johannes McKay (now at Keysight Technologies, Inc.).

The Mössbauer instruments saw a very significant decrease in usage during 2017 (106 days) due to the departure of the staff member, Sebastian Stoian (now on the faculty at the University of Idaho), who single-handedly ran the facility for the past four years. It should be noted that this capability was originally funded via a UCGP and staffed by the Lab-funded Crow Postdoctoral Fellow. There are currently no plans to staff the facility going forward, although it will be possible for users to access the instruments from time-to-time with assistance from graduate students in the EMR program.



# Chapter 3 – User Facilities

EMR

EMR

## Magneto-Structural Correlations in a Transition Metal Complex

E. A. Suturina<sup>1,2</sup>, J. Nehr Korn<sup>3</sup>, J. M. Zadrozny<sup>4,5</sup>, J. Liu<sup>5,6</sup>, M. Atanasov<sup>1,6</sup>, T. Weyhermüller<sup>1</sup>, D. Maganas<sup>1</sup>, S. Hill<sup>5</sup>, A. Schnegg<sup>3</sup>, E. Bill<sup>1</sup>, J. R. Long<sup>4</sup>, F. Neese<sup>1</sup>

1. Max Planck Institute for Chemical Energy Conversion; 2. Novosibirsk State University; 3. Helmholtz-Zentrum Berlin; 4. UC Berkeley; 5. Northwestern; 5. NHMFL; 6. University of Oxford; 6. Bulgarian Academy of Sciences  
Funding: G.S. Boebinger (NSF DMR-1157490); J.R. Long (NSF CHE-1464841); E.A. Suturina (Russian Science Foundation); A. Schnegg (DFG)

In the field of modern inorganic materials science, magneto-structural correlations in transition-metal complexes have been used to rationally design molecules with desirable magnetic properties. These magnetic properties, in turn, can be related to the electronic and geometric structures to provide powerful insights into important catalytic processes and active sites in metallo-proteins. To this end, two pseudo-tetrahedral cobalt-II complexes, denoted as  $[\text{Co}^{\text{II}}(\text{SPh})_4]^{2-}$  complexes, were synthesized to mimic the  $[\text{Fe}^{\text{II}}(\text{S-cysteine})_4]^{2-}$  sites in the Fe-S protein rubredoxin. In this case, cobalt-II provides a powerful electron paramagnetic resonance (EPR) probe, although its extreme magnetic anisotropy necessitates the use of very high magnetic fields (see figure).

The present study combines theory, magnetometry, high-field EPR, and magneto-optical techniques to precisely determine the magnetic anisotropy parameters of  $(\text{PPh}_4)_2[\text{Co}^{\text{II}}(\text{SPh})_4]$  and  $(\text{NEt}_4)_2[\text{Co}^{\text{II}}(\text{SPh})_4]$ . The results reveal a surprisingly strong dependence of these parameters on the S-Co-S angle,  $\vartheta$ , and the C-S-Co-S torsion angle,  $\psi$ , around the  $\text{CoS}_4$  core (see upper inset), with the axial anisotropy ( $2D$ ) changing both sign (easy-axis/easy-plane) and magnitude. These findings are important both in the area of bio-inorganic chemistry, and in the development of improved molecular nanomagnets with enhanced magnetic anisotropy.

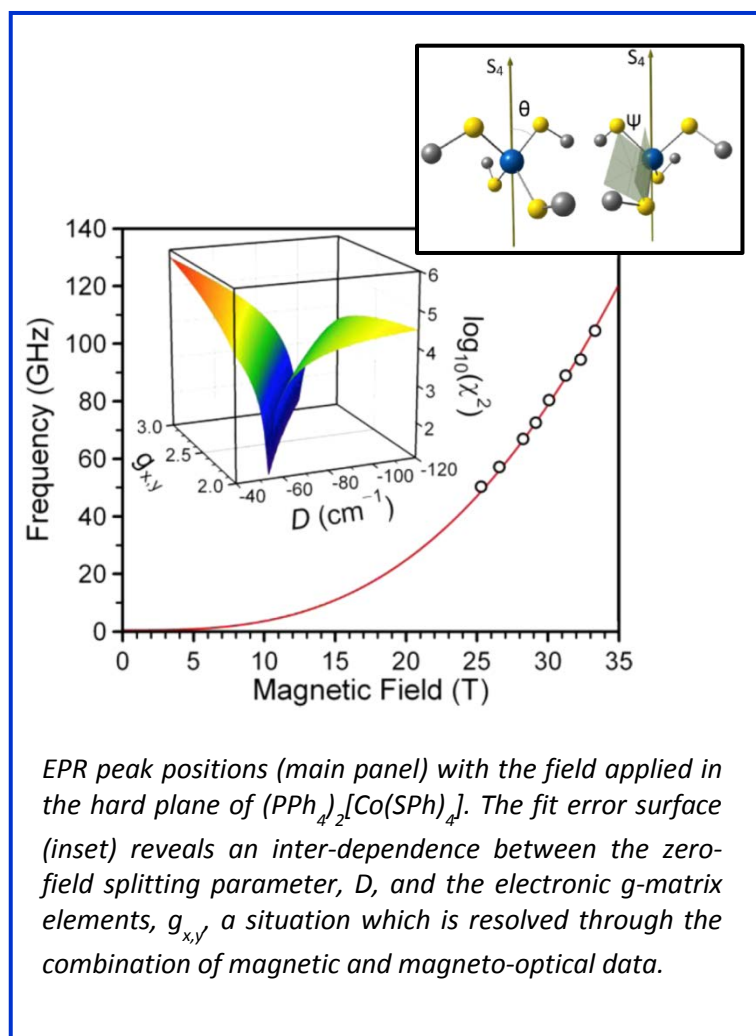

**Facilities:** EMR & DC Field (35 T, 32 mm bore resistive magnet)

**Citation:** Suturina, E. A.; Nehr Korn, J.; Zadrozny, J. M.; Liu, J.; Atanasov, M.; Weyhermüller, T.; Maganas, D.; Hill, S.; Schnegg, A.; Bill, E.; Long, J. R.; Neese, F., Magneto-Structural Correlations in Pseudotetrahedral Forms of the  $[\text{Co}(\text{SPh})_4]^{2-}$  Complex Probed by Magnetometry, MCD Spectroscopy, Advanced EPR Techniques, and ab Initio Electronic Structure Calculations, *Inorganic Chemistry* **56**, 3102-3118 (2017).

# Chapter 3 – User Facilities

EMR

EMR

## Across the Tree of Life: Radiation Resistance Gauged by High-Field EPR

A. Sharma<sup>1</sup>, E.K. Gaidamakova<sup>2,3</sup>, O. Grichenko<sup>2,3</sup>, V.Y. Matrosova<sup>2,3</sup>, V. Hoeke<sup>1</sup>, P. Klimenkova<sup>2,3</sup>, I. H. Conze<sup>2,4</sup>, R.P. Volpe<sup>2,3</sup>, R. Tkavc<sup>2,3</sup>, C. Gostinčar<sup>5</sup>, N. Gunde-Cimerman<sup>5</sup>, J. DiRuggiero<sup>6</sup>, I. Shuryak<sup>7</sup>, A. Ozarowski<sup>8</sup>, B.M. Hoffman<sup>1</sup>, M.J. Daly<sup>2</sup>

1. Northwestern University; 2. Uniformed Services University of Health Sciences; 3. Henry M. Jackson Foundation for the Advancement of Military Medicine; 4. University of Bielefeld; 5. University of Ljubljana; 6. Johns Hopkins University; 7 Columbia University; 8. NHMFL

Funding Grants: G.S. Boebinger (NSF DMR-1157490); B. Hoffman (NIH GM111097); M. Daly (HDTRA1620354); I Shuryak

Decades of research have failed to predict the ability of cells to survive ionizing radiation (IR). Evidence is mounting that small high-symmetry antioxidant complexes of manganese ions with metabolites (H-Mn<sup>2+</sup>) are responsible for cellular IR resistance, and that H-Mn<sup>2+</sup> protects the proteome, not the genome, from IR-induced reactive oxygen species.

This collaborative study shows that the amount of H-Mn<sup>2+</sup> in non-irradiated living cells is readily gauged by electron paramagnetic resonance (EPR) spectroscopy and is highly diagnostic of DNA repair efficiency and survival after gamma radiation exposure. Importantly, the high resolving power of high-field EPR is essential for proving that the enzyme manganese superoxide dismutase (MnSOD) is present in negligible amounts in the bacterium *Deinococcus Radiodurans* (*Dr*), which is capable of surviving radiation doses 20-fold greater than *Escherichia coli* (*Ec*), thereby disproving previous assertions that MnSOD is critical in the IR survival of *Dr*. Indeed, the narrow 6-line EPR spectrum of *Dr* (see Fig.) is characteristic of the high symmetry H-Mn<sup>2+</sup>.

This spectroscopic study of H-Mn<sup>2+</sup> content is the strongest known biological indicator of cellular IR resistance between and within the three domains of the tree of life, with potential applications including optimization of radiotherapy.

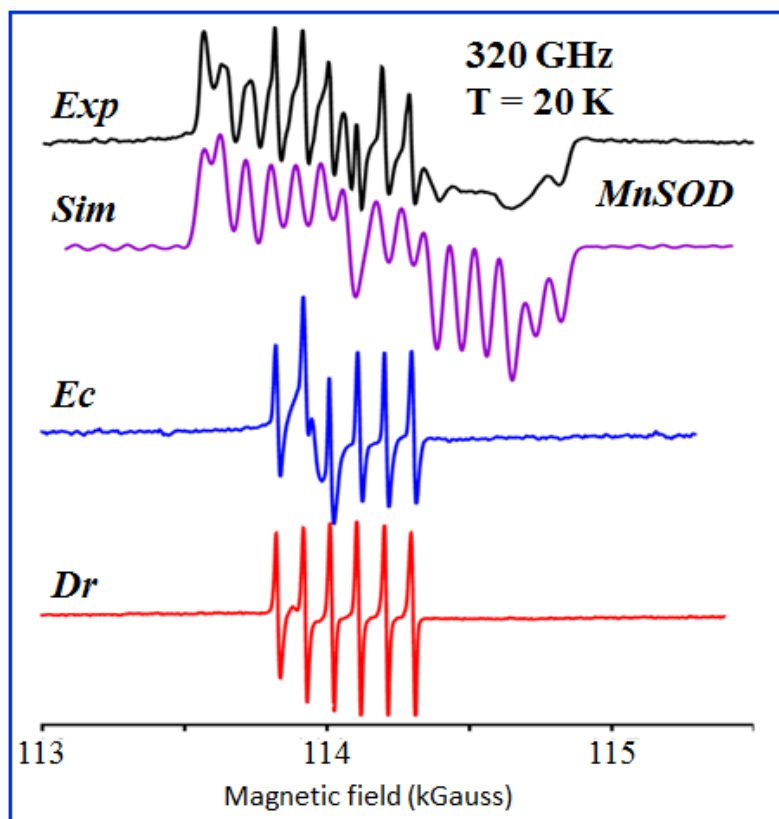

**Facilities and instrumentation used:** Electron Magnetic Resonance, 15/17 T Broadband Transmission Spectrometer

**Citation:** A. Sharma, E.K. Gaidamakova, O. Grichenko, V.Y. Matrosova, V. Hoeke, P. Klimenkova, I. H. Conze, R.P. Volpe, R. Tkavc, C. Gostinčar, N. Gunde-Cimerman, J. DiRuggiero, I. Shuryak, A. Ozarowski, B.M. Hoffman, M.J. Daly, *Across the tree of life, radiation resistance is governed by antioxidant Mn<sup>2+</sup>, gauged by paramagnetic resonance*, **Proc. Natl. Acad. Sci. USA** **114**, E9253 – E9260 (2017).

# Chapter 3 – User Facilities

HBT

HBT

## 3.6.4. High B/T Facility

The High B/T facility provides users with a unique combination of high magnetic fields (up to 16T) and ultra-low temperatures down to 1mK for long durations (~ a few weeks). It is possible to cool to much lower temperatures ~ 0.4 mK for short times depending on the nature of the sample and the method of thermal linkage to the nuclear refrigerators (Users should consult with staff on the best approaches to use.). A suite of specialized instrumentation is available for users conducting studies of magnetic or electric susceptibilities, nuclear magnetic, and nuclear quadrupole resonance, transport, ultrasound, and thermal properties of modern materials in an ultra-quiet environment designed for high-sensitivity studies.

### 3.6.4.1. Unique Aspects of Instrumentation Capability

#### 3.6.4.1.1. Multi-component demountable cells for magnetic and electric susceptibility measurements at ultra-low temperatures.

Demountable and inter-changeable cells are available for measuring ac magnetic susceptibilities and dielectric constants down to sub-mK temperatures. The

samples are immersed in liquid  $^3\text{He}$  to ensure thermal contact to a silver post that is an integral part of a nuclear refrigerator. Sintered silver heat exchangers (made from 50 $\mu\text{m}$  Ag powder) are also used to thermalize all electric leads entering and leaving the cells.

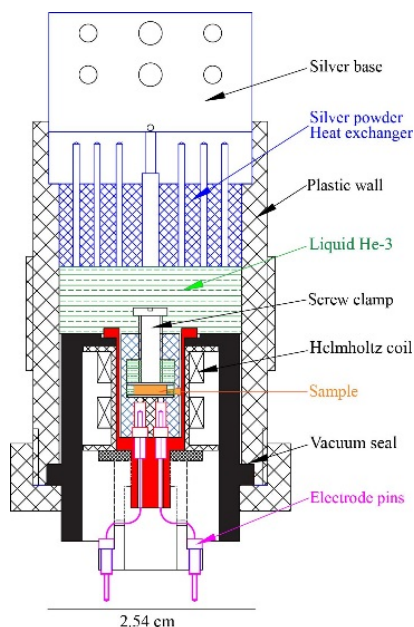

**Figure 1a:** Dielectric susceptibility cell used for measuring the magneto-electric effects in a doped organic quantum magnet. [J. S. Xia et al., *J. Low Temp. Phys.* **187**,627 (2017).]

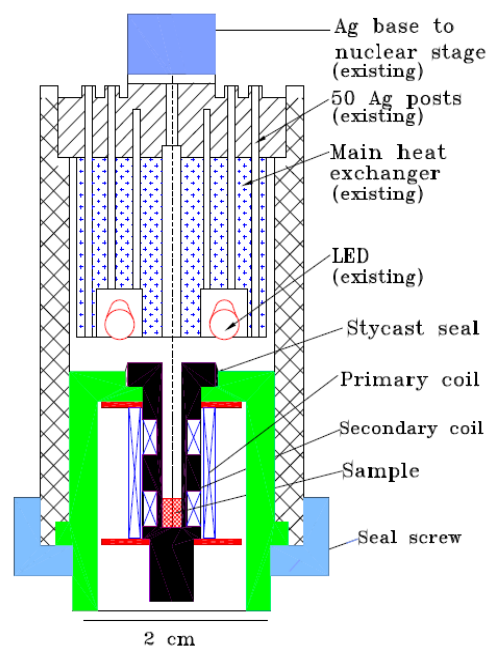
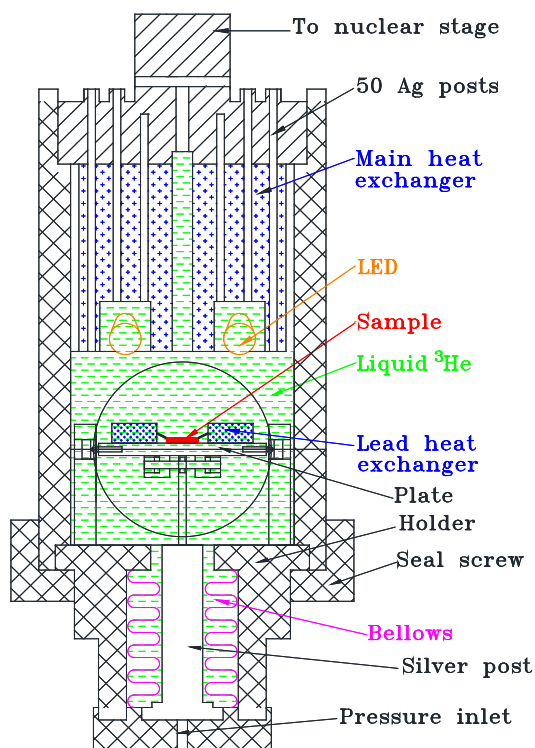

**Figure 1b:** Magnetic susceptibility cell used for measuring phase changes to a Bose glass state at high magnetic fields and very low temperatures. [R. Yu et al., *Nature* **489**, 379-384 (2012).]

# Chapter 3 – User Facilities

HBT

Recent studies of the quantum Hall effect at exotic quantum Hall numbers have required the use of devices that can tilt the sample with respect to the magnetic field. This is accomplished (**Figure 2**) by using liquid  $^3\text{He}$  to pressurize a bellows that drives a platform mounted on jeweled bearings. Angles of  $-10^\circ$  to  $90^\circ$  (vertical) with an accuracy of  $0.2^\circ$  at  $T = 1$  mK and for fields up to 15T have been realized.



**Figure 2:** Ultra-low temperature tiltor using same structure as figures 1a and 1b with insert that contains a soft bellows that is used to tilt a sample relative to an applied magnetic field. This cell is currently used for transport studies of a GaAs-p quantum well, and has been used for quantum Hall Effect measurements [Zhang et al., Phys. Rev. **B85**, 241302(2012)].

### 3.6.4.1.2. High sensitivity NMR for studies at very low temperatures

High sensitivity NMR is available for studies of very dilute systems or other systems where the signal/noise is very low. Samples are placed in thermal contact with a silver post that is an integral part of a nuclear refrigerator and the sample coil is matched *in-situ* at low temperatures to a 50-ohm low-loss

HBT

superconducting transmission line that feeds one arm of a wide-band hybrid tee at room temperature. In suitable cases, such as low-temperature bridge circuits, low-power RF amplifiers can be deployed at the sample site (using pHEMPT transistors) to create very low noise temperatures. The spectrometer is designed to reach 1,000 MHz and can also be used for NQR studies.

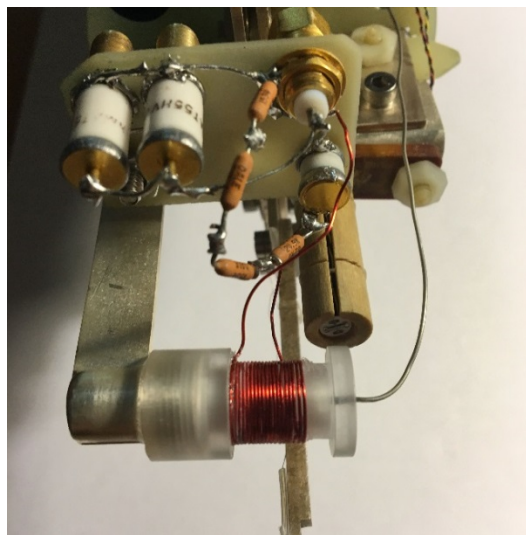

**Figure 3:** Single coil NMR probe mounted on silver post forms a nuclear demagnetization refrigerator. The capacitors are used to match the coil to transmission line that is connected to one arm of a broadband hybrid tee.

### 3.6.4.1.3. Other specialized instrumentation

Yoonseok Lee has led a team of undergraduate researchers in the development of user friendly  $^3\text{He}$ - $^4\text{He}$  separator. With the wide use of liquid  $^3\text{He}$  as a thermalizing agent in ultra-low temperature systems and the large volume use of  $^3\text{He}/^4\text{He}$  mixtures for high circulation refrigerators, there is a wide-spread need for a simple system for purifying  $^3\text{He}$  to a few ppm. A compact scalable  $^3\text{He}$  purifier has been designed and assembled around a simple charcoal absorption column that is inserted in a regular liquid helium dewar to adsorb the helium from an original contaminated sample. The temperature of the absorption column is controlled by the position in the dewar. By changing the temperature of desorption,  $^3\text{He}$  gas can be distilled preferentially leaving  $^4\text{He}$  or  $\text{H}_2$  gas impurities on the adsorber to be removed at a later stage.

# Chapter 3 – User Facilities

HBT

## 3.6.4.2. Facility Developments and Enhancements

The roof hatches above each of the high quality electromagnetically shielded rooms (bay 1, bay 2, and bay 3) that house superconducting magnets will be modified to permit automatic opening in the case of a magnet quench. This safety enhancement was planned for the last quarter of 2017, but has rolled over to the first quarter of 2018. Delays in user time are expected.

We are developing low-temperature ultra-low noise radio-frequency capabilities in the form of contactless techniques to measure RF conductivities and the real and imaginary components of RF magnetic susceptibilities in new materials. Tunnel diode oscillators are being tested for their high-sensitivity and low-power dissipation. These devices can also, in principle, be used for NMR and EMR studies at very high frequencies. The performance of these systems in high magnetic fields is not well understood.

## 3.6.4.3. Major Research Activities and Discoveries

### 3.6.4.3.1. Unusual magnetic response of the $S = 1$ antiferromagnetic linear-chain material $[\text{Ni}(\text{HF}_2)(3\text{Clpy})_4]\text{BF}_4$ (known as NBCT)

J.S. Xia, (NHMFL-High B/T); A. Ozarowski, (NHMFL, EMR); P.M. Spurgeon, (Eastern Washington Univ., Chemistry); A.G. Graham, (Eastern Washington Univ., Chemistry); J.L. Manson, (Eastern Washington Univ., Chemistry); and M.W. Meisel (NHMFL, High B/T and UF Physics).

An  $S = 1$  antiferromagnetic polymeric chain, with chemical formula  $[\text{Ni}(\text{HF}_2)(3\text{-Clpy})_4]\text{BF}_4$  (py = pyridine), commonly referred to as “NBCT”, has been identified to have nearest-neighbor antiferromagnetic interaction  $J/k_B = 4.86$  K and single-ion anisotropy  $D/k_B = 4.3$  K, while avoiding long-range order down to 25 mK. With  $D/J = 0.88$ , this system is close to the  $D/J \approx 1$  gapless quantum critical point between the topologically distinct Haldane and Large- $D$  phases.

The magnetization of NBCT was studied over a range of temperatures,  $50 \text{ mK} \leq T \leq 1 \text{ K}$ , and magnetic fields,  $B \leq 10 \text{ T}$ . The results at low-field, **Figure 1**, allow an upper bound of the critical field,  $B_C$ , which closes the gap to be estimated. Specifically,  $B_C \leq (35 \pm 10) \text{ mT}$ , which is close to the predicted value of 46 mT [2], when assuming a Haldane system and using the reported values of  $J$ ,  $D$ , and  $g$  [1]. In low-fields, the magnetic signal increases with decreasing temperature for

HBT

$400 \text{ mK} < T < 800 \text{ mK}$  but is independent of temperature for  $50 \text{ mK} \leq T \leq 400 \text{ mK}$ . This observation is consistent with a significant increase in the specific heat arising from the accumulation of entropy in the vicinity of the quantum critical point.

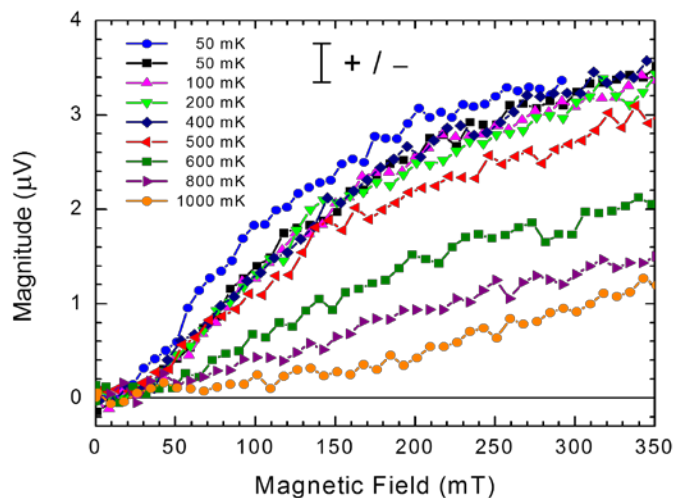

**Figure 4:** The magnitudes of the voltages, after background subtraction, are shown versus low magnetic field. The overall uncertainty is represented by the “+/-” bar. The apparent degeneracy of the data sets for  $T \leq 400 \text{ mK}$  is conjectured to be evidence of the increase of entropy near the critical point. The critical field necessary to close any gap, if it exists, has an upper bound of  $B_C \leq (35 \pm 10) \text{ mT}$ , and is similar to the value of 45 mT obtained from numerical work when assuming a Haldane system with the parameters reported in J. L. Manson, et al., *Inorg. Chem.*, **51**, 7520-7528 (2012).

### 3.6.4.3.2. Transport of dilute $\text{MgZnO}/\text{ZnO}$ heterostructures

J. Falson, D. Tabrea, and J.H. Smet (Max Planck Institute, Stuttgart, Germany)

The  $\text{MgZnO}/\text{ZnO}$  heterostructure hosts a high-mobility two-dimensional electron system (2DES) at its hetero-interface which shows a maximum mobility exceeding  $1 \times 10^6 \text{ cm}^2/\text{Vs}$ . The carriers at low temperature and high magnetic field elicit unique facets of correlated electron physics, including rich fractional quantum Hall features. In this work, we have measured ultra-dilute hetero-structures with charge density  $n \sim 1.9 \times 10^{10} \text{ cm}^{-2}$ . The magneto-transport is shown in **Figure 5**, as taken in Bay 3 of the High B/T facility at the

# Chapter 3 – User Facilities

HBT

University of Florida. The preliminary results confirm that even the most diluted samples available remain metallic down to ultra-low  $T < 1$  mK, and display robust integer quantum Hall physics.

The verification of metallicity of dilute MgZnO/ZnO samples suggests them as a novel platform to study strongly interacting carriers in the context of quantum criticality. Future studies will incorporate more sophisticated measurement techniques, such as gated heterostructures and sample rotation to investigate charge density dependence and spin polarization of ground states.

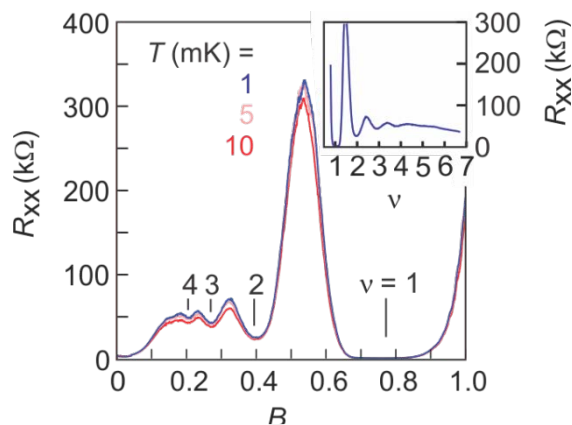

**Figure 5:** Temperature dependent ( $T = 1, 5$  and  $10$  mK) magnetotransport of a dilute MgZnO/ZnO heterostructure. Robust integer quantum Hall features are observed. Inset: Magnetoresistance as a function of filling factor. Integer steps between 1 and 4 suggest all levels are spin resolved.

### 3.6.4.3.3. Dynamics of $^3\text{He}$ in nanotubes

D. Candela (Univ. of Massachusetts), C. Huan, N. Masuhara (NHMFL High B/T), J. Adams, M. Lewkowski and N. S. Sullivan (UF Physics)

The confinement of quantum fluids in nanotubes, including Helium-3 ( $^3\text{He}$ ), Helium-4 ( $^4\text{He}$ ), and Hydrogen ( $\text{H}_2$ ), for which the deBroglie wavelength and/or Fermi length become comparable to or larger than the channel size has been predicted to lead to emergent quantum behaviors. We have carried out experiments designed to search for these new quantum behaviors for  $^3\text{He}$  constrained to move in 1D channels. Special low temperature pulsed NMR techniques to determine the temperature dependence of the dynamics of  $^3\text{He}$  atoms confined to the interior of the

HBT

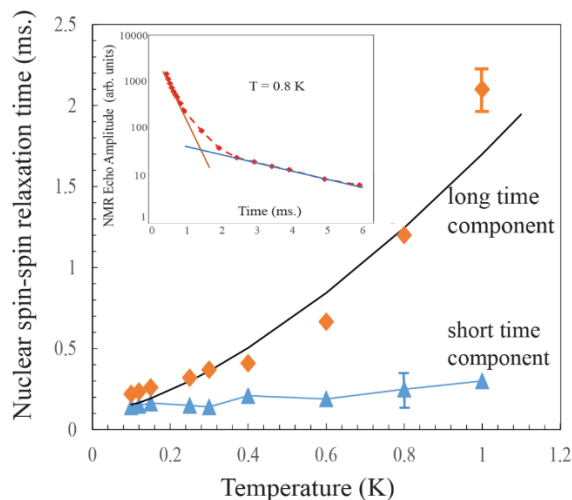

**Figure 6:** Temperature dependence of NMR relaxation times for  $^3\text{He}$  confined to the interior of MCM-41 nanochannels. The inset shows the clear separation of two components of  $^3\text{He}$ , with the short time component corresponding to  $^3\text{He}$  atoms on the wall of the nanochannel and the long time component corresponding to the Fermi gas confined to the one-dimensional space in the nanochannel.

hexagonal nanoscale channels of MCM-41. The typical nanochannel diameter in this material is only 1.5 nm, with lengths greater than 300 nm.

A spin-echo radio-frequency (RF) pulse sequence is followed by an NMR spin-lattice relaxation that consists of two distinct relaxation components attributed, respectively, to the  $^3\text{He}$  atoms on the walls of the nanochannel (the shorter relaxation time) and atoms free to move in the center of the nanochannel (long time relaxation). The long time relaxation shown in **Figure 6** exhibits the characteristic  $T^{3/2}$  dependence that is expected for a Fermi gas confined to a one-dimensional space.

### 3.6.4.4. Facility Plans and Directions

With the recent success of the high temperature superconducting (HTS) insert coils that have been able to reach above 40T when inserted into a conventional low temperature superconducting (LTS) magnet. We have proposed developing a special HTS magnet facility that has available both high circulation rate dilution refrigerators for low temperature users, and high temperature inserts (for experiments up to  $\sim 2,000\text{K}$ ) for materials science and engineering studies.

# Chapter 3 – User Facilities

HBT

This new facility would use the UF Physics High bay space that could accommodate up to three HTS magnet systems that would also include a magnet dedicated to AMRIS.

### 3.6.4.5. Outreach to Generate New Proposals-Progress on STEM and Building User Community

In 2017, the NHMFL coordinator at the University of Florida, Elizabeth Webb, and graduate students and post-doctoral fellows working with her visited 79 classrooms in 18 schools, reaching 1,700 students as part of the NHMFL classroom outreach program in Gainesville. An additional 19 presentations were made at 4 schools reaching 195 students as part of summer programs at area schools and the afterschool science program Elizabeth runs.

This year, Elizabeth co-organized the Women in Science and Engineering (WiSE) Girls spring break camp with AMRIS employee Malathy Elumalai. This weeklong camp brought middle school girls from Alachua County to the University of Florida to learn about a variety of different sciences, and included a tour of and magnet demonstration at the High B/T Facility.

Engaging with teachers and school groups is an annual practice at High B/T, and this year, Facility leadership and staff lead 2 tours, reaching 20 college high school students and teachers; participated in 3 Family Science Nights at local middle and elementary schools, reaching 600-1,000 students; presented at 2 career fairs, reaching 450 middle school students; and judged middle school science fairs as well as the Alachua County Science Fair.

### 3.6.4.6. Facility Operations Schedule

The majority of the experiments conducted at the High B/T Facility need a dedicated study of the experimental cell in order to be certain that the sample can reach ultra-low temperatures in the course of the measurements being proposed by users. This study is necessary because of the high Kapitza thermal

HBT



**Figure 7:** Professor Mark Meisel demonstrates heat/cooling effects of polymers to the WiSE girls Spring camp in 2017.

resistance at ultra-low temperatures. Users work closely with High B/T staff in the design, construction and testing of the cells. The experiments can take one to nine months to complete and for this reason the facility operated 24/7 for 301 days in 2017. Magnet availability at the high B/T facility was terminated during the time of Hurricane Irma. The magnets were de-energized for safety, and this resulted in two experiments being prematurely halted. Normal shutdowns are planned to occur whenever possible at the same time as major scientific meetings in the fields, notably for the March APS meetings and the International Low Temperature Physics Conferences.

### 3.6.4.7. Performance Goals- Present and Future

The current waiting time for users who have approved proposals for magnet time is about nine months. This could be reduced by opening another nuclear demagnetization refrigerator (0.1 mK, 8T) for user operations. The timing for this improvement is dependent on available funding as it requires obtaining additional staff and new equipment funding.

# Chapter 3 – User Facilities

HBT

HBT

## Helium-Three Nanodroplet Growth in Solid Helium Solutions: A Surrogate for Phase Separations in Metal Alloys

D. Candela<sup>1</sup>, B. Cowan<sup>2</sup>, C. Huan<sup>3</sup>, L. Yin<sup>3</sup>, J. S. Xia<sup>3</sup>, N.S. Sullivan<sup>3</sup>

1. University of Massachusetts (Amherst); 2. Royal Holloway, University of London; 3. University of Florida

Funding Grants: G.S. Boebinger (NSF DMR-1157490); B. P. Cowan (EPSRC-Award EP/E023177/1);

N.S. Sullivan (NSF DMR-1303599)

Phase separations are of fundamental importance in condensed matter physics because they play a major role in the preparation of new materials, including high-strength alloys. However, basic information about phase separations is limited because the typical time scales for the kinetics of phase separations can be days to years...too long to practically measure. This fundamental experimental barrier to studying phase separations is overcome by studying solid mixtures of the two isotopes of helium,  $^3\text{He}$  and  $^4\text{He}$ , in which the underlying physical time-scale is determined by quantum diffusion. Quantum diffusion is orders of magnitude faster than classical thermal diffusion in metallic alloys.

MagLab users accessed unique ultra-low-temperature NMR techniques to track phase separation in very dilute solutions of  $^3\text{He}$  in solid  $^4\text{He}$  at densities as low as 16 parts per million, a regime in which  $^3\text{He}$  atoms form nanoscale droplets that are Fermi degenerate. Due to the decrease in NMR signal from the liquid  $^3\text{He}$  droplets, researchers can track evolution of the phase separation accurately from the amplitude of the NMR signal.

After a short period of nucleation following supercooling, large droplets above a critical size grow by capturing  $^3\text{He}$  atoms that diffuse through the solid  $^4\text{He}$ . These  $^3\text{He}$  atoms originate from the dissolving of smaller  $^3\text{He}$  droplets that are below the critical size. In this “coarsening” period – called “Ostwald ripening” – the growth rate of the droplet size, hence the decay rate of the NMR signal, is determined by the capture at the surface of the droplet, which leads to a one-third power law as a function of time.

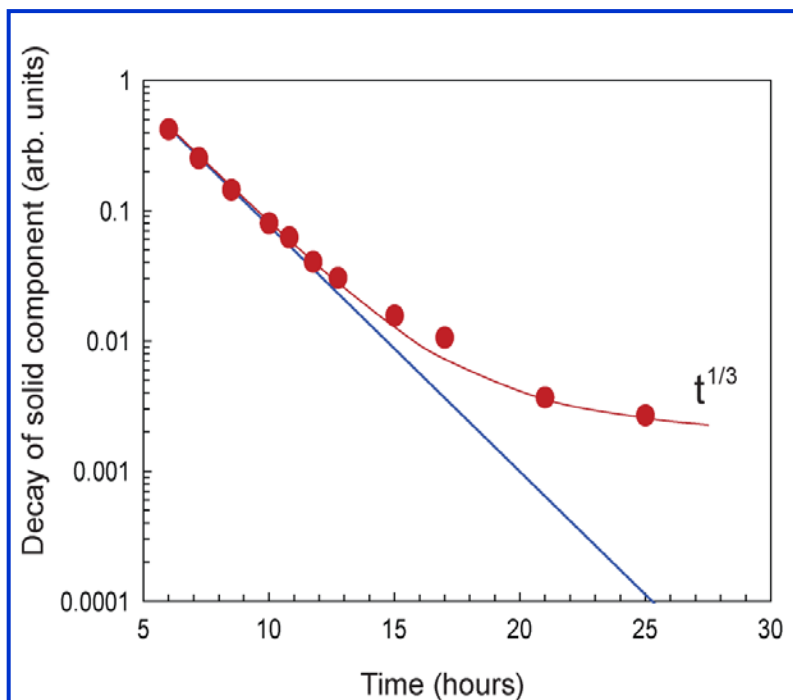

**Figure:** Long-time decay of the NMR amplitude arising from solid helium-three that tracks the loss of the solid component to the formation of degenerate Fermi liquids in nanodroplets. Following the nucleation period and exponential decay (denoted by the straight line) the results show the predicted  $t^{1/3}$  decay from the coarsening of droplet size known as Ostwald ripening.

**Facilities:** Bay 3 of the MagLab’s High B/T Facility at the University of Florida

**Citation:** C. Huan, L. Yin, J. S. Xia, B. Cowan, D. Candela and N. S. Sullivan, *Phase separation in dilute solutions of  $^3\text{He}$  in solid  $^4\text{He}$* , **Physical Review B95**, 104107 (2017).



# Chapter 3 – User Facilities

ICR

ICR

## 5. ICR Facility

During 2016, the Fourier Transform Ion Cyclotron Resonance (ICR) Mass Spectrometry program continued instrument and technique development as well as pursuing novel applications of FT-ICR mass spectrometry. These methods are made available to external users through the NSF National High-Field FT-ICR Mass Spectrometry Facility. The facility features seven staff scientists who support instrumentation, software, biological, petrochemical, and environmental applications, as well as a machinist, technician, and several rotating postdocs who are available to collaborate and/or assist with projects.

### 5.1. Unique Aspects of Instrumentation Capability

The Ion Cyclotron Resonance facility provides operations for sample analysis that requires the ultrahigh resolution ( $m/\Delta m_{50\%} > 1,000,000$  at  $m/z$  500, where  $\Delta m_{50\%}$  is the full mass spectral peak width at half-maximum peak height) and sub-ppm mass accuracy only achievable by FT-ICR MS coupled to high magnetic fields. The facility's four FT-ICR mass spectrometers feature high magnetic fields < 21 tesla, and are compatible with multiple ionization and fragmentation techniques.

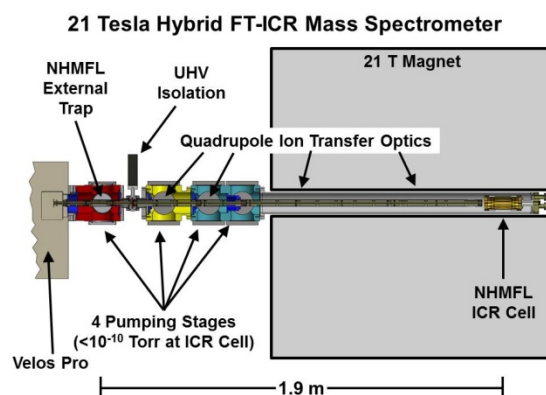

**Figure 1.** Schematic of the 21 tesla FT-ICR mass spectrometer. Approximately half of the magnet cross-section is shown. Differentially pumped vacuum chambers are shown in red, yellow, and blue (the blue chamber contains two differentially pumped regions, the second of which includes the ICR cell). The scale at the bottom shows the approximate distance from the external quadrupole trap to the ICR cell.

ICR Systems at the Magnet Lab in Tallahassee		
Field (T), Bore (mm)	Homogeneity	Ionization Techniques
21, 123	< 1ppm	ESI, AP/LIAD-CI, APCI, DART
14.5, 104	1 ppm	ESI, AP/LIAD-CI, APCI, DART
9.4, 220	1 ppm	ESI, AP/LIAD-CI, APCI, APPI FT-ICR, DART,
9.4, 155	1 ppm	FD, LD FT-ICR

### 5.2. Facility Developments and Enhancements

In 2015, the ICR facility revealed the design and initial performance of the **first actively-shielded 21 tesla Fourier transform ion cyclotron resonance mass spectrometer**. The 21 tesla magnet is the highest field superconducting magnet ever used for FT-ICR and features high spatial homogeneity, high temporal stability, and negligible liquid helium consumption (*J. Am. Soc. Mass Spectrom.*, **26**, 1626-1632 (2015)).

Mass resolving power of 150,000 ( $m/\Delta m_{50\%}$ ) is achieved for bovine serum albumin (66 kDa) for a 0.38 second detection period and greater than 2,000,000 resolving power is achieved for a 12 second detection period. Externally calibrated broadband mass measurement accuracy is typically less than 150 ppb rms, with resolving power greater than 300,000 at  $m/z$  400 for a 0.76 second detection period. The ultrahigh mass accuracy and extensive residue cleavages from 21 tesla FT-ICR MS/MS facilitate myeloma cell mutation status monitoring, precision diagnosis, and personalized medicine development.

The instrument is part of the NSF High-Field FT-ICR User Facility and is available free of charge to qualified users.

# Chapter 3 – User Facilities

ICR

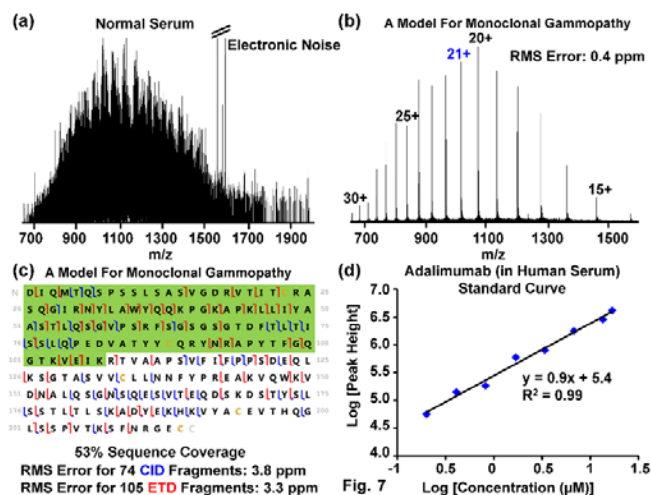

**Figure 2.** Mass spectra from a normal human serum (a) and normal human serum spiked with 15 µM of adalimumab (b) as a model for multiple myeloma (c) Amino acid sequence coverage for the mAb, adalimumab, light chain. The variable region sequence (in green) differentiates adalimumab from other mAbs, and the remaining constant region sequence identifies adalimumab light chain isotype as kappa. (d) Adalimumab (in human serum) quantitation generated by our nano-LC FT-ICR MS method.

The instrument includes a commercial dual linear quadrupole trap front end that features high sensitivity, precise control of trapped ion number, and collisional and electron transfer dissociation. A third linear quadrupole trap offers high ion capacity and ejection efficiency, and rf quadrupole ion injection optics deliver ions to a novel dynamically harmonized ICR cell.

An **actively-shielded 14.5T**, 104 mm bore system offers the highest mass measurement accuracy (<300 parts-per-billion rms error) and highest combination of scan rate and mass resolving power available in the world. The spectrometer features electrospray, atmospheric pressure photoionization (APPI), atmospheric pressure chemical ionization sources (APCI); linear quadrupole trap for external ion storage, mass selection, and collisional dissociation (CAD); and automatic gain control (AGC) for accurate and precise control of charge delivered to the ICR cell. The combination of AGC and high magnetic field make

ICR

sub-ppm mass accuracy routine without the need for an internal calibrant. Robotic sample handling allows unattended or remote operation. An additional pumping stage has been added to improve resolution of small molecules. (*Rapid Commun. Mass Spectrom.*, **31**, 207-217 (2017)).

The **9.4T, passively-shielded**, 220 mm bore system offers a unique combination of mass resolving power ( $m/\Delta m = 8,000,000$  at mass 9,000 Da) and dynamic range (>10,000:1), as well as high mass range, mass accuracy, dual-electrospray source for accurate internal mass calibration, efficient tandem mass spectrometry (as high as  $MS^8$ ), and long ion storage period (*J. Am. Soc. Mass Spectrom.*, **25**, 943-949 (2014)). A redesign to the custom-built mass spectrometer coupled to the 9.4T, 200 mm bore superconducting magnet designed around custom vacuum chambers has improved ion optical alignment, minimized distance from the external ion trap to magnetic field center, and facilitates high conductance for effective differential pumping (*J. Am. Soc. Mass Spectrom.* **22**, 1343-1351, (2011)). The length of the transfer optics is 30% shorter than the prior system, for reduced time-of-flight mass discrimination and increased ion transmission and trapping efficiency at the ICR cell. When applied to compositionally complex organic mixtures such as dissolved organic matter (*Water Research*, **96**, 225-235 (2016)); *Env. Sci. Technol.*, **50**, 3391-3398 (2016)), biofuels (*Energy Fuels*, **31**, 2896-2906 (2017)), and petroleum fractions (*Energy Fuels*, **31**, 10674-10679 (2017)), mass spectrometer performance improves significantly, because those mixtures are replete with mass “splints” that are readily separated and identified by FT-ICR MS (*Nature Commun.*, **8**, 1089 (2017)). The magnet is passively shielded to allow proper function of all equipment and safety for users. The system features external mass selection prior to ion injection for further increase in dynamic range and rapid (~100 ms time scale) MS/MS (*Anal. Chem.*, **75**, 3256-3262 (2003)). Available dissociation techniques include collision-induced (CID), infrared multiphoton-induced (IRMPD) (*Anal. Chem.*, **89**, 8304-8310 (2017)), and electron capture-induced (ECD) (*J. Phys. Chem. A.*, **117**, 1189-1196 (2013)).

The **9.4T actively shielded** FT-ICR instrument is available for analysis of complex nonpolar mixtures and instrumentation development. The 9.4T magnet is

# Chapter 3 – User Facilities

ICR

currently used for field desorption (*Anal. Chem.*, **80**, 7379-7382 (2008)) and elemental cluster analysis, and reported the formation of the smallest fullerene by stabilization through cage encapsulation of a metal by use of a pulsed laser vaporization cluster source (*J. Org. Chem.*, **82**, 893-897 (2017)) which indicates that metallofullerenes should be constituents of stellar/circumstellar and interstellar space as well as fullerenes (*Nature. Commun.*, **8**, 1222 (2017)).

## 5.3. Major Research Activities and Discoveries

**Automated broadband phase correction** of FT-ICR data can in principle produce an absorption-mode spectrum with mass resolving power as much as a factor of 2 higher than conventional magnitude-mode display, an improvement otherwise requiring a more expensive increase in magnetic field strength. We present atmospheric pressure photoionization (APPI) Fourier transform ion cyclotron resonance (FTICR) mass analysis of a volcanic asphalt sample by acquiring data for 20 Da wide mass segments across a 1000 Da range, stitched into a single composite mass spectrum, and compare to a broadband mass spectrum for the same sample (**Figure 4**) (*Anal. Chem.*, **89**, 11318-11324 (2017)).

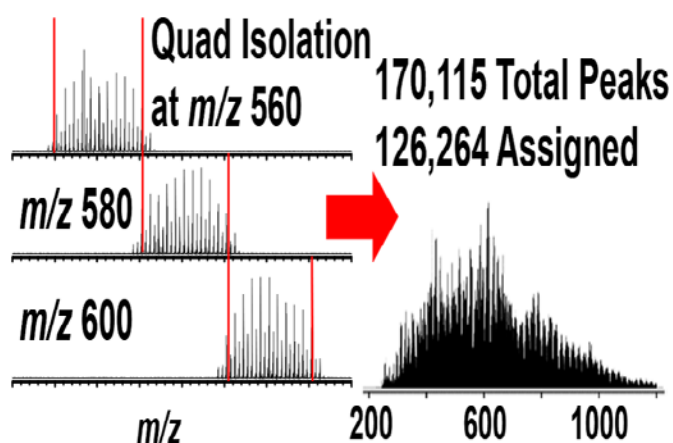

**Figure 4. Left:** Isolation of mass spectral segments for increased dynamic range, because the ICR ion trap could be filled with ions spanning only a fraction of the full mass range. **Right:** Segments stitched to yield a single

ICR

composite mass spectrum with record numbers of resolved and assigned peaks.

To the best of our knowledge, this mass spectrum represents the most peaks resolved and identified in a single spectrum of any kind, and represents the highest broadband resolving power for any petroleum mass spectrum, and emphasizes the need for ultrahigh resolving power achievable only by FT-ICR MS sufficient to separate isobaric overlaps prevalent in complex seep samples.

Tertiary and quaternary structure can also be probed. Automated **hydrogen/deuterium exchange** improved by depletion of heavy isotopes ( $^{13}\text{C}/^{15}\text{N}$ ) for protein subunits of a complex can greatly simplify the mass spectrum, increase the signal-to-noise ratio of depleted fragment ions, and remove the ambiguity in assignment of  $m/z$  values to the correct isomeric species.

The detailed characterization of large protein assemblies in solution remains challenging to impossible. Nonetheless, these large complexes are common and often of exceptional importance. **Hydrogen/Deuterium exchange (HDX)** experiments reveal changes in deuteration over time to examine protein-protein contacts. Proteins are diluted into a  $\text{D}_2\text{O}$  solution to induce the exchange of hydrogen atoms with deuterium. The degree of protection from deuterium exchange is indicative of local structure as well as dynamics. (**Figure 4**). Extracellular domain 1 (EC1) has a lower deuterium uptake percentage than the EC2 region, consistent with the higher stability of the first domain. As seen in **Fig.1**, averaged relative difference in deuterium (ARDD) uptake for NCAD12 apo dimer and monomer are mapped onto PDB crystal structure (4NUM) of  $\text{Ca}^{2+}$  saturated NCAD12 because no crystal structure for the apo dimer exists. The ARDD map shows significant protection within EC2 upon dimer formation, defining this as an adhesive interface region not consistent with the current crystal structure. It is clear from this region in EC2 that the  $\text{D}_{\text{sat}}$  structure shown does not represent the structure of the kinetically trapped NCAD12 apo dimer,  $\text{D}^*_{\text{apo}}$ .

# Chapter 3 – User Facilities

ICR

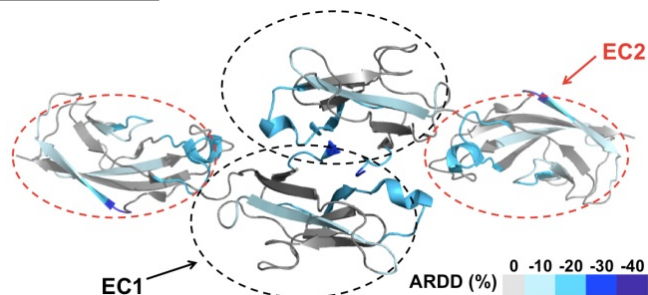

**Figure 4 left:** Averaged relative difference in deuterium (ARDD) uptake between NCAD12 apo dimer and monomer mapped on PDB 4NUM crystal structure of mouse NCAD EC1-2 A78SI92M. The potential adhesive interface segments are defined as regions with overlapping peptides that have ARDD values more than -10%; meaning at least a 10% reduction of HDX upon dimerization.

The 9.4T and 14.5T instruments are primed for immediate impact in **environmental and petrochemical analysis**, where previously intractably complex mixtures are common. The field of “petroleomics” has been developed largely due to the unique ability of high-field FT-ICR mass spectrometry to resolve and identify all of the components in petroleum samples.

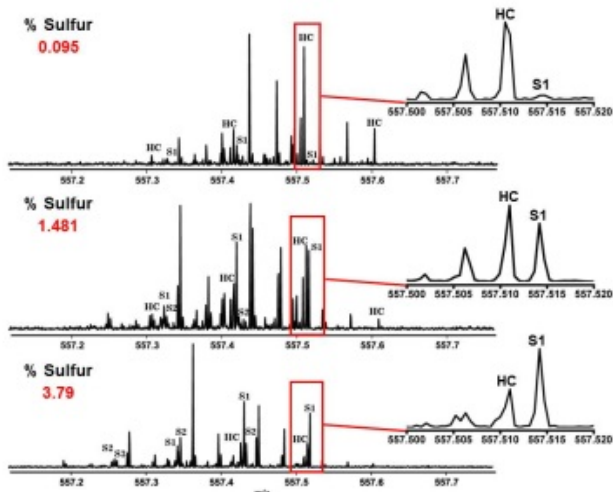

**Figure 5. (Left)** Zoom inset ( $\Delta m/z$  0.5) of the broadband (+) APP FT-ICR mass spectra and (right) further zoom mass inset ( $\Delta m/z$  0.02) for three selected crude oil samples with sulfur contents for (top) 0.095%, (middle) 1.48%, and (bottom) 3.79%. At the lowest sulfur concentration analyzed (top), the hydrocarbon class is clearly most abundant. However, with increased sulfur concentration, the signal magnitude of the  $S_1$ -containing compounds increases relative to the hydrocarbon class (from top to bottom), and at the highest total sulfur value (bottom), the most abundant class shifts to the  $S_1$  class. Furthermore, the signal magnitude for the  $S_2$  and  $S_3$  classes (left) increases concurrently with sulfur concentration.

ICR

An ultimate goal in **carbon nanoscience** is to decipher formation mechanisms of highly ordered systems. Here, chemical processes are discovered that result in formation of high symmetry clusterfullerenes (e.g.,  $M_3N@C_{80}$ ), which are materials that offer promise in applications that span biomedicine to molecular electronics. Graphite doped with metal and nitrogen was vaporized with a high energy laser to synthesize 80 carbon-atom-containing fullerene cages that encapsulate a  $M_3N$  ( $M$  = metal) cluster through ultrafast self-assembly processes. The nanocarbon reactions involved in the transformation of graphite into spherical cages were tracked by the MagLab’s powerful 9.4 tesla FT-ICR mass spectrometer. Through the ultrahigh resolution capabilities afforded by the MagLab instrument, it was discovered that these technologically important nanocages are formed by a distinct ‘bottom-up’ mechanism (*Nature Commun.* **8**, 1222 (2017)), **Figure 6.**

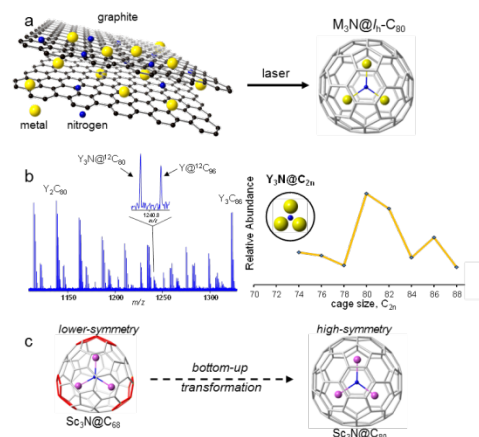

**Figure 6. (a)** The clusterfullerene,  $M_3N@I_h-C_{80}$ , is formed by direct laser vaporization of metal- and nitrogen-doped graphite. **(b)** The complex nanocarbon products are analyzed by FT-ICR mass spectrometry. The formation distribution for the  $M_3N@C_{2n}$  ( $C_{2n}$  = even

# Chapter 3 – User Facilities

## ICR

numbered carbon cage) shows that  $Y_3N@C_{80}$  is an abundant molecular formation product. (c) Bottom-upgrowth of a small clusterfullerene,  $Sc_3N@C_{68}$ , into  $Sc_3N@C_{80}$ .

### 5.4. Facility Plans and Directions

The ICR facility will continue to expand its user facility to include user access to the world's first 21 tesla FT-ICR mass spectrometer.

### 5.5. Outreach to Generate New Proposals-Progress on STEM and Building User Community

The ICR program had **23** new principal investigators in 2017. The ICR program also enhanced its undergraduate research and outreach program for 6 undergraduate scientists (three female). The ICR program in 2017 supported the attendance of research faculty; postdoctoral associates; and graduate, undergraduate, and high school students at numerous national conferences to present current results.

## ICR

### 5.6. Facility Operations Schedule

The ICR facility operates year-round, with weekend instrument use scheduled. Two shifts (8 hours each) are scheduled for each instrument year-round, including holiday shut-downs, which are utilized for routine instrument maintenance.

### 5.7. The Future Fuel Institute

The Future Fuels Institute completed its fourth full year in 2017, with two full share members (\$250K each / year for 4 years) to support research to address challenges associated with petroleum production, processing, and upgrading. The Future Fuels Institute currently supports 1 fulltime technician and 2.5 fulltime research faculty to pursue analytical method development. For 2017, the corporate members are: Reliance and Total. Additionally, the FFI partners with two instrument manufacturers (Leco Instruments, Waters Instrument Company) for state-of-the-art instrumentation prior to commercial release.

# Chapter 3 – User Facilities

ICR

ICR

## Transformation of Carbon Sheets into High-Tech Nanocages

Marc Mulet-Gas<sup>1</sup>, Laura Abella<sup>2</sup>, Maira R. Cerón<sup>3</sup>, Edison Castro<sup>3</sup>, Alan G. Marshall<sup>1</sup>, Antonio Rodríguez-Forteza<sup>2</sup>, Luis Echevoyen<sup>3</sup>, Josep M. Poblet<sup>2</sup> and Paul W. Dunk<sup>1</sup>

1. National MagLab, FSU; 2. University of Texas at El Paso, USA; 3. Universitat Rovira I Virgili, Spain

Funding Grants: G.S. Boebinger (NSF DMR-1157490); Echevoyen (NSF CHE-140885, DMR-1205302)

An ultimate goal in carbon nanoscience is to decipher formation mechanisms of highly ordered systems. Here, chemical processes are discovered that result in formation of high symmetry clusterfullerenes, for example, the  $M_3N$  atoms ( $M = \text{metal}$ ) enclosed in a  $C_{80}$  cage (denoted  $M_3N@C_{80}$ ). These materials offer promise for applications that span the range from molecular electronics to renewable energy to biomedicine.

Graphite doped with metal and nitrogen was vaporized with a high energy laser to synthesize 80 carbon-atom-containing fullerene cages that encapsulate a  $M_3N$  cluster through ultrafast self-assembly processes. The nanocarbon reactions involved in the transformation of graphite into spherical cages were tracked by the MagLab's powerful 9.4 tesla FT-ICR mass spectrometer. Through the ultrahigh resolution capabilities afforded by the MagLab instrument, it was discovered that these technologically important nanocages are formed by a distinct 'bottom-up' mechanism...with smaller nanocages developing into larger nanocages.

This work discloses intrinsic chemical processes that are a fundamental property of carbon under the 'harsh' conditions typical of synthesis. These experiments probe nanocarbon structure formation for hybrid carbon allotropes which should facilitate the discovery of entirely new forms of molecular nanocarbon and nanocage cluster compounds.

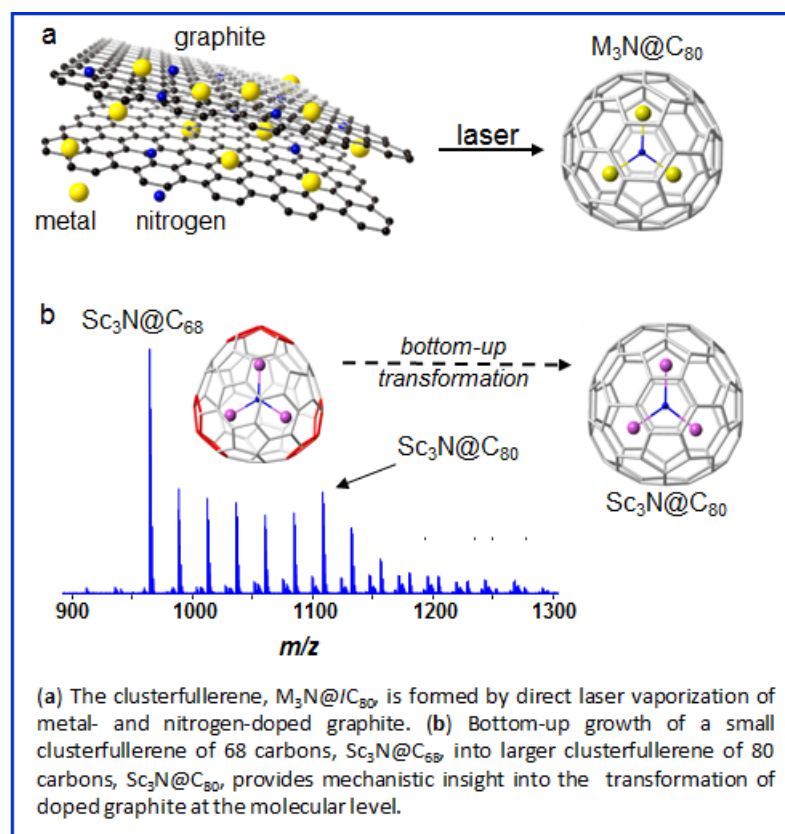

**Facilities and instrumentation used:** Ion Cyclotron Resonance

**Citation:** Transformation of Doped Graphite into Cluster-Encapsulated Fullerene Cages, M. Mulet-Gas, L. Abella, M.R. Cerón, E. Castro, A.G. Marshall, A. Rodríguez-Forteza, L. Echevoyen, J.M. Poblet and P.W. Dunk, **Nature Communications** 8, 1222 (2017)

# Chapter 3 – User Facilities

ICR

ICR

## Human Protein Identification by 21 T FT-ICR Mass Spectrometry

L.C. Anderson<sup>1</sup>, C.J. DeHart<sup>1,2</sup>, N.K. Kaiser<sup>1</sup>, R.T. Fellers<sup>2</sup>, D.F. Smith<sup>1</sup>, J.B. Greer<sup>2</sup>, R.D. LeDuc<sup>2</sup>, G.T. Blakney<sup>1</sup>,  
P.M. Thomas<sup>2</sup>, N.L. Kelleher<sup>2,3</sup>, C.L. Hendrickson<sup>1,4</sup>

1. National High Magnetic Field Laboratory; 2. Proteomics Center of Excellence, Northwestern University; 3. Department of Chemistry and Molecular Biosciences, Northwestern University; 4. Department of Chemistry and Biochemistry, FSU

Funding Grants: G.S. Boebinger (NSF DMR-1157490); N.K. Kelleher (NIH P41GM108569)

It is estimated that there are over a million structurally unique proteins (“proteoforms”) in human cells. Each proteoform has the potential to impact health and disease. However, limitations of commercial mass spectrometers (MS) require hundreds of experiments to obtain reasonable coverage of the human proteome. Furthermore, commercial MS is typically limited to molecular weights below 30 kDa, rendering half the human proteome inaccessible.

Researchers’ first experiments with the MagLab’s 21 Tesla FT-ICR mass spectrometer produced more detected proteins and proteoforms per experiment than any prior work (Figure 1A): the largest prior high-throughput human protein study had focused on smaller proteins of <30 kDa and identified 2.5 unique protein sequences per liquid chromatography mass spectrometry/mass spectrometry (LC-MS/MS) experiment. By contrast, we achieved more than 72 protein identifications per experiment, setting a new efficiency standard for intact protein analysis. Additionally, proteins identified ranged in size from 5 kDa all the way up to 55 kDa (Figure 1B), which is a two-fold higher mass range than the prior work.

The improved throughput, sequence coverage and molecular weight range available with the MagLab’s 21 Tesla FT-ICR mass spectrometer will facilitate discovery of potentially thousands of new proteoforms, a significant portion of which will have direct clinical relevance to human disease.

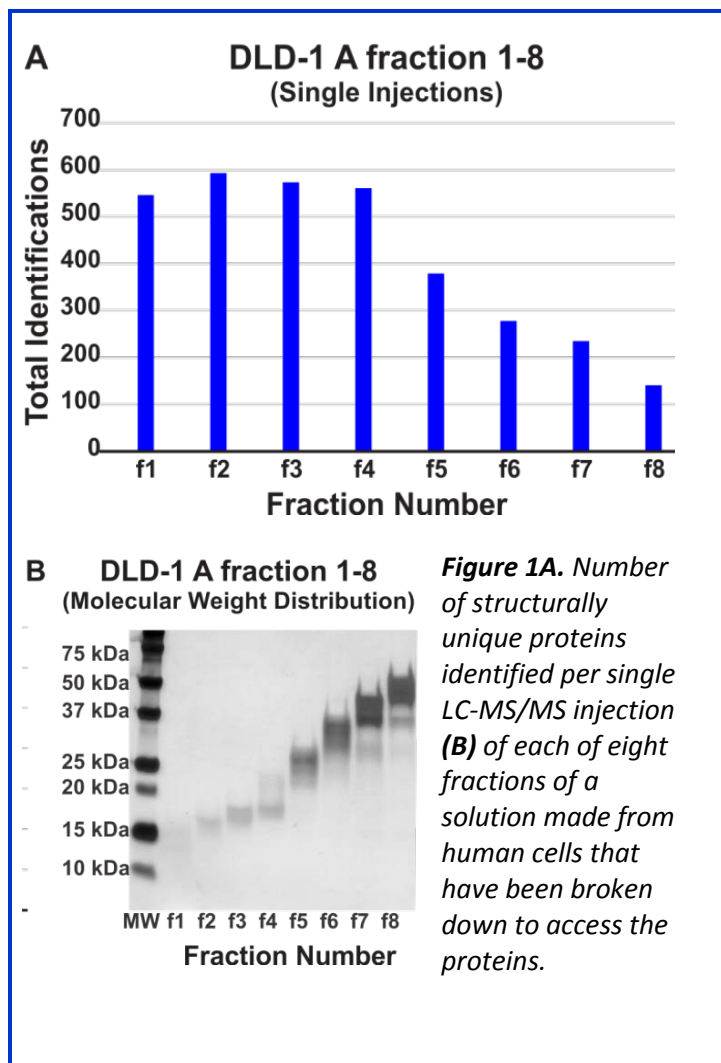

**Facilities:** Ion Cyclotron Resonance (21 T FT-ICR MS)

**Citation:** Identification and Characterization of Human Proteoforms by Top-Down LC-21 Tesla FT-ICR Mass Spectrometry. L.C. Anderson, C.J. DeHart, N.K. Kaiser, R.T. Fellers, D.F. Smith, J.B. Greer, R.D. LeDuc, G.T. Blakney, P.M. Thomas, N.K. Kelleher, C.L. Hendrickson. *Journal of Proteome Research* 2017, 16 (2), 1087-1096.

# Chapter 3 – User Facilities

NMR

NMR

## 6. NMR/MRI Facility, Tallahassee

*The NMR and MRI User Program in Tallahassee is a partner with the AMRIS facility of the NHMFL at the University of Florida in Gainesville. The Tallahassee facility offers scientists access to high magnetic fields with the world's highest sensitivity NMR and MRI probe technology. Our flagship 900 MHz ultra-wide bore spectrometer is the world's highest field instrument for in vivo MRI/S and also offers high sensitivity probes for materials and biological solid state NMR. We also offer Dynamic Nuclear Polarization (DNP) spectroscopy at 600 MHz as a user facility. This instrument provides much higher sensitivity for biological solids and for materials research than is available from NMR. Lower field instruments offer users additional unique capabilities in solution and solid state NMR. Our technology efforts continue to be focused on the development of innovative probes for triple resonance solid state NMR for both oriented sample and magic angle sample spinning, high field in vivo imaging and spectroscopy, as well as high sensitivity solution NMR probes. This past year the Series Connected Hybrid (SCH) magnet, a combination of a 14T superconducting coil and 22T resistive insert went through a 1 year Commissioning Phase. The homogeneity and stability of the field is currently less than 0.2 ppm and efforts are under way to further enhance this magnet's performance for NMR spectroscopy at 1500 MHz for protons. Data from the last three years (2013-2015) for which we have data analyzed show how successful the MagLab NMR/MRI Facility has been: 401 users from 120 institutions spanning 19 countries crediting 179 different grants.*

### 6.1. Unique aspects of instrument capability

A unique user facility has been launched in the United States at the NHMFL – a 35 Tesla magnet having a  $^1\text{H}$  resonance frequency of 1.5 GHz, the highest field and frequency for NMR in the world breaking the world record by 50%. This magnet is a Series Connected Hybrid magnet having a 12T superconducting outer component and a 21T inner resistive magnet. The high inductance of the superconducting component helps to stabilize the DC power supply induced field fluctuations, especially all of the multiples of 60 Hz. The result is a magnet with field stability of 0.14 ppm permitting a broad range of solid state NMR to be performed. During this past year we have gone through a commissioning phase with the magnet, with the Bruker Neo console, and with the three high performance NMR probes designed and constructed at the MagLab. To facilitate user operations the NMR/MRI facility in collaboration with the AMRIS facility has secured a P41 National resource grant from NIH to facilitate user activities and training on the SCH as well as activities associated with the DNP and in solution NMR field of metabolomics.

The 600 MHz Dynamic Nuclear Polarization (DNP) Facility is in full user mode taking advantage of the NIH National Resource funding and a High End Instrumentation grant for a sweepable  $14.1 \pm 0.13\text{T}$  magnet that was installed this past year and an NSF MRI grant for a gyrotron plus NSF and State of Florida NHMFL support to assemble this instrument that

provides ultra-high sensitivity NMR spectroscopy of materials and biological solid state NMR to our national and international user community.

The MagLab is making strides towards ultrafast Magic Angle Sample Spinning (MAS). The first 1.3 mm probes with top rotational rates of 60 kHz are operating now. 0.75mm 110 kHz MAS stators are in house and probes are being designed for this state of the art technology for solid state NMR. Fast MAS spinners and ultra-high magnetic fields are ushering in a new era for NMR, one in which proton detection is possible with ultra-high spectral resolution and sensitivity. This is similar to the revolution that occurred in the 1980's when solution NMR spectroscopy gained proton detection capabilities. That opened a flood-gate for protein structural characterization of water soluble proteins. Now for solid state NMR a similar flood-gate can be opened for proteins that are not water soluble such as membrane proteins and proteins that form fibrils, such as amyloid fibers. We hope to have these MAS probes available for the community in late 2018 or early 2019.

The future of NMR is going to be at field strengths far above those that can be generated with Low-Temperature Superconductors (LTS). High Temperature Superconducting (HTS) materials development is progressing apace with the potential to more than double current NMR field strengths and the MagLab is at the forefront of this technology thanks to



# Chapter 3 – User Facilities

## NMR

support from NSF, NIH, and DOE. This past year, MS&T produced an all superconducting magnet at 32 T using a combination of LTS and HTS materials. This magnet will be used by Condensed Matter Physics, but we anticipate obtaining accurate maps of the field homogeneity and stability during 2018. Considerable advances in the materials and magnet technology are still needed prior to the development of a persistent and highly stable LTS/HTS magnet that will be optimal for all of NMR and MRI.

In the meantime, the SCH magnet is allowing us to peer into the future when we will have persistent LTS/HTS magnets operating at such fields. Sensitivity for many nuclei increase with  $B_0^{3/2}$  and signal averaging time decreases as the square of this factor, i.e.  $B_0^3$ . For quadrupolar nuclei the sensitivity factor can be  $B_0^{5/2}$  or even  $B_0^{7/2}$ . One of the most exciting prospects in the biological and material sciences is the study of  $^{17}\text{O}$ . It is at the oxygen atoms where much of biological and materials chemistry takes place and yet it has not been possible to routinely observe these nuclei because of the poor sensitivity and severe resonance overlap. Preliminary results from the SCH show both superb resolution and sensitivity.

### 6.2. Facility developments and enhancements

Despite years of development effort to get DNP to be a commercial product, there is a great deal of work left to be done to have this technology be a routine tool. Robust infrastructure needs to be installed, more robust probes than what is available commercially need to be developed. Sample preparation techniques need to be developed to gain the highest benefit from this technology. Additional temperature range is needed for many studies. Plans have been made and the NIH BTRR will be providing much of the necessary resources for such probe developments.

For the SCH magnet, first generation MAS and Oriented Sample NMR probes are being used, but there will certainly be a need for multiple generations of probes that enhance NMR performance over the years to come. Indeed, this is very exciting, because there is

## NMR

an opportunity to do this prior to the development of very high field and very expensive LTS/HTS all superconducting magnets.

### 6.3. Major research activities and discoveries

Recently, there has been great advances made in the resolution of Cryo-EM and Cryo-tomography that sometimes claim atomic resolution, but in fact are at approximately  $3\text{\AA}$  resolution, so like X-ray crystallography they cannot see the hydrogen atoms. So what is unique about NMR spectroscopic studies. First, it is able to characterize these molecular structures in a much more native like environment. This is important since the amino acid sequence or the nucleotide sequence alone does not determine the molecular structure. Instead, it is a combination of the molecular interactions within the molecule and between the molecule and its environment that dictates the structure. Importantly, NMR is inherently atomic resolution, as the observed signals are obtained from individual atomic sites. Structures can be determined at atomic resolution in these native-like environments by characterizing distances or torsion angles in the structure or by characterizing orientations to the magnetic field of the NMR spectrometer. Secondly, NMR can uniquely determine the dynamics or molecular motions that occur within the molecular structure over a frequency range from nanoseconds to milliseconds. In addition, it is now possible to characterize details of the functional mechanism of these proteins that function as molecular machines as was recently achieved by Fu and coworkers (FSU & MagLab) for the M2 protein that is a proton channel in the Influenza A viral coat. Importantly, this is just an example of the significant science that can be uniquely achieved through the use of NMR spectroscopy.

Along similar lines of thought, the science community would like to understand how proteins function within the cellular environment. This is not possible if one has to purify the protein conducting the chemistry first such as is necessary for X-ray crystallography and Cryo-EM. This past year Frederick (UT-Southwestern) obtained detailed conformational insights for a protein in its native cellular environment using the MagLab's new 600 MHz DNP User Facility.

# Chapter 3 – User Facilities

## NMR

### 6.4. Facility Plans and Directions

From its very beginning, the NMR/MRI program has been supporting and grant writing for the MagLab design and construction of unique magnets for NMR/MRI. First, was the development of the Ultra-Wide Bore 900 Magnet that was brought to field in 2004 and generates data for a publication a month even 13 years later! Second, is the SCH 36T magnet that is operating as a user facility for the first time in January of 2018. This magnet will help us peer into the future of NMR and generate data for justifying LTS/HTS all superconducting magnets. Proposals for such developments will be written in the coming year. While Europe has placed orders for nine 1.2 GHz LTS/HTS magnets, there have been no deliveries and none are expected in the coming year, although it is possible that a 1.1 GHz magnet may be delivered in 2018.

Investments in high temperature superconducting magnet development need to be made. In November 2014 a workshop on Ultra-High Field NMR was held in DC sponsored by the NSF, NIH, and DOE. A report has been written and published as a Strategic Plan for National NMR/MRI facilities by many members of the NMR community, including MagLab personnel, identifying a design for facilities that would make Ultra-High Field NMR spectrometers available to a broad scientific community and would equip them with novel probe technology and maintain the instruments at state of the art performance.

## NMR

In collaboration with Prof. Jeffrey Schiano at Penn State, the NHMFL has been developing technology to stabilize powered magnets. This technology is nearly ready to be tested on the SCH and our plan is that we will be able to perform high resolution solid state NMR spectroscopy with this instrument.

### 6.5. Outreach to generate new proposals - progress on STEM and building user community

Our primary mechanism for recruiting new users involves one-on-one contact with potential users at national and international meetings with follow up to bring those users here. Our staff scientists go to important national and international meetings annually, and one of their tasks at these meetings is to identify new users and to follow up with them when they return to the MagLab. A greater challenge that we are beginning to work on is to recruit users who are not NMR spectroscopists, but scientists that could use NMR data for the science they do. This opens the NHMFL facility to a much broader and more diverse community of biological and chemical scientists.

### 6.6. Facility operations schedule

The NMR/MRI facilities are open 24/7 and for 365 days of the year. The only down time is when there is a need for instrument maintenance. The SCH is available at field for a maximum of 31 hours per week.

# Chapter 3 – User Facilities

NMR

NMR

## <sup>17</sup>O Magic-Angle Spinning NMR using 36T Series-Connected-Hybrid Magnet

Eric G. Keeler, Vladimir K. Michaelis, Michael T. Colvin, Robert G. Griffin (MIT)

Zhehong Gan, Ivan Hung, Xiaoling Wang, Joana Paulino, Ilya M. Litvak, Peter L. Gor'kov,

William W. Brey, Mark D. Bird, Timothy A. Cross (NHMFL)

Funding Grants: G.S. Boebinger (NSF DMR-1157490); M.D. Bird and W. Brey (DMR-1039938 and DMR-0603042)  
T.A. Cross (NIH P41 GM122698); R.G. Griffin (NIH EB-001960, EB-002804, and EB-002026)

Oxygen is one of the most important elements in chemistry, biology and material sciences due to its active role in reactions. The potential of <sup>17</sup>O NMR for obtaining detailed structural, dynamic and functional information has yet to be fully realized, primarily due to <sup>17</sup>O having a low gyromagnetic ratio ( $\gamma = -5.774 \text{ MHz T}^{-1}$ ), low natural isotopic abundance (0.037%) and an  $I = 5/2$  spin which produces complex quadrupolar NMR spectra. High magnetic fields are critical to fully enable <sup>17</sup>O NMR because they dramatically enhance spectral resolution and sensitivity, particularly when coupled with a reduction of the residual second-order quadrupolar broadening under magic-angle spinning (MAS).

The MagLab has recently commissioned a 36T Series-Connected-Hybrid (SCH) magnet that offers 50% higher magnetic fields than the highest superconducting NMR magnet available today. The magnetic field is homogeneous and stable to better than 1 ppm over  $1 \text{ cm}^3$  DSV. This field quality enables high-resolution multi-dimensional NMR experiments for <sup>17</sup>O and, in future experiments, for other quadrupolar nuclei throughout the periodic table.

Researchers from MIT partnered with MagLab scientists to record the first <sup>17</sup>O NMR spectra of biological samples taken in a 35.2T magnetic field (corresponding to a 1.5GHz resonance frequency for <sup>1</sup>H). The results demonstrate the field qualities of the SCH magnet and advantages of the 35.2T field for <sup>17</sup>O NMR. The SCH magnet is now open to researchers from around the world.

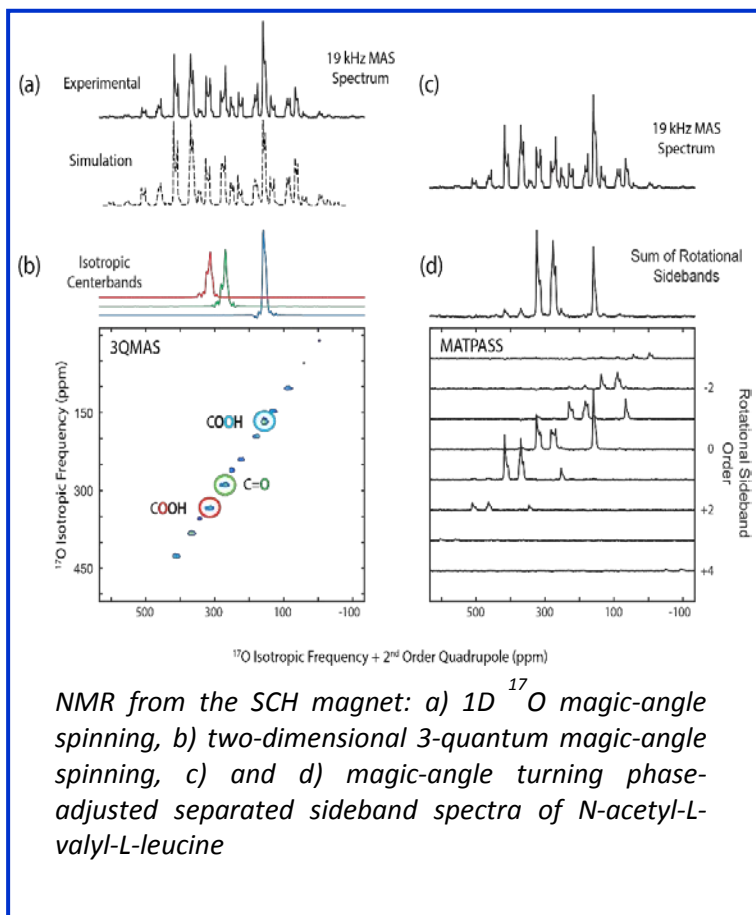

NMR from the SCH magnet: a) 1D <sup>17</sup>O magic-angle spinning, b) two-dimensional 3-quantum magic-angle spinning, c) and d) magic-angle turning phase-adjusted separated sideband spectra of N-acetyl-L-leucine

**Facility:** DC Field and NMR Facilities, 36 T Series Connected Hybrid

**Citation 1:** Keeler, E.G.; Michaelis, V.K.; Colvin, M.T.; Hung, I.; Gor'kov, P.L.; Cross, T.A.; Gan, Z. and Griffin, R.G., <sup>17</sup>O MAS NMR Correlation Spectroscopy at High Magnetic Fields. **J. Am. Chem. Soc.** (2017), 139, 17953–17963.

**Citation 2:** Gan, Z.; Hung, I.; Wang, X.; Paulino, J.; Wu, G.; Litvak, I.M.; Gor'kov, P.L.; Brey, W.W.; Lendi, P.; Schiano, J.L.; Bird, M.D.; Dixon, I.R.; Toth, J.; Boebinger, G.S. and Cross, T.A., NMR spectroscopy up to 35.2 T using a series-connected hybrid magnet, **Journal of Magnetic Resonance** 284 (2017) 125–136.

# Chapter 3 – User Facilities

NMR

NMR

## Tracking Lithium Transport Pathways in Solid Electrolytes for Batteries

Jin Zheng<sup>1</sup>, Mingxue Tang<sup>1</sup>, Po-Hsiu Chien<sup>1</sup>, Kevin Huang<sup>2</sup>, Hailong Chen<sup>3</sup>, Yan-Yan, Hu<sup>1</sup>

1. Florida State University; 2. University of South Carolina; 3 Georgia Institute of Technology

Funding Grants: G.S. Boebinger (NSF DMR-1157490); Y.-Y. Hu (NSF DMR 1508404)

Most commercially-available rechargeable lithium batteries contain liquid-based electrolytes and, thus, face several challenges, including safety issues, energy density, and cost. New all-solid-state batteries are addressing these challenges, yet fundamental research is necessary at this early stage to help realize their potential.

By developing a new method to track lithium (Li) transport pathways in solid electrolytes, this work develops a fundamental understanding that facilitates improvement of Li ion conductivity for future technologies. Experts in electrolyte synthesis produced our high-performance solid electrolytes. These new Lithium-6 → Lithium-7 isotope replacement experiments reveal that Li transport pathways vary significantly, depending on the composition and structure of the solid electrolytes. The experiments were performed in the MagLab's 11.7-T magnet with a 2.5 mm magic-angle-spinning NMR probe and an *in operando* NMR probe designed by the MagLab for battery research.

The in operando NMR measurements provide real-time tracking of Li ion transport under real battery operating conditions. The gained knowledge will help guide battery materials design and device fabrication for future high-performance, all-solid-state rechargeable batteries.

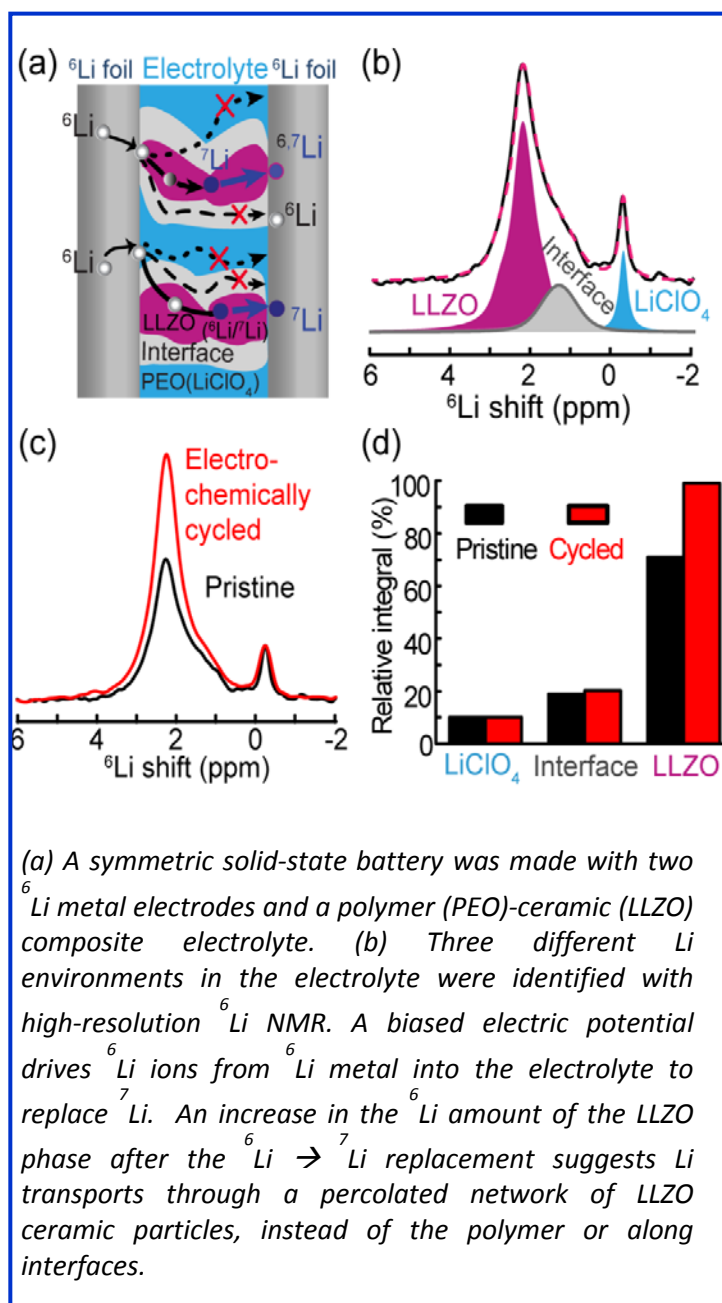

**Facilities:** NMR/MRI Facility at the NHMFL/FSU

**Citation:** Zheng, J.; Tang, M. and Hu, Y.Y., *Lithium Ion Pathway within Li<sub>7</sub>La<sub>3</sub>Zr<sub>2</sub>O<sub>12</sub>-Polyethylene Oxide Composite Electrolytes.*, *Angew. Chem. Int. Ed.*, **55** (40), 12538-12542 (2016)

# Chapter 3 – User Facilities

PFF

PFF

## 7. Pulsed Field Facility

*The National High Magnetic Field Laboratory - Pulsed Field Facility (NHMFL-PFF) is located in Los Alamos, New Mexico, at the Los Alamos National Laboratory (LANL) – also home to another world class user program, the Center for Integrated Nano Technology (CINT). The NHMFL-PFF utilizes LANL and US Department of Energy (DOE) owned equipment and resources to provide world record pulsed magnetic fields to users from the scientific and engineering community worldwide. The pulsed field users program is engineered to provide researchers with a balance of the highest research magnetic fields and robust scientific diagnostics specifically designed to operate in pulsed magnets. The connection with the DC Field Facility is strong and complementary in expertise. Although achieving the highest research magnetic fields possible is a fundamental competency at the NHMFL-PFF, we also strive to create the very best high-field research environment and to provide users with support from the world’s leading experts in pulsed magnet science. All of the user support scientists are active researchers and collaborate with multiple users per year. A fully multiplexed (6-output) and computer controlled, 4.0 mega-Joule (32 mF @ 16 kV) capacitor bank system is at the heart of the short pulse magnet activities. Many thousands of 20 millisecond long high magnetic field pulses up to 65 tesla are fired for the user program, which accommodates approximately 150 different users, each year. Beyond the workhorse short pulse magnets, we provide users with the highest non-destructive magnetic fields available worldwide. The 100’s of mega-Joules necessary are provided by a 1.4 GW AC generator, a truly unique pulsed power supply. The AC rectification allows for a greatly flexible pulsed power waveform to be delivered and customized to optimize performance of the associated magnet system (enabling technology for both the 100T multishot and 60T controlled waveform magnets). Pulsed field users have access to magnetic fields exceeding 100 tesla using the semi-destructive Single Turn magnet system which produces 6 microsecond duration magnetic field pulses to 300 tesla.*

### 7.1. Unique Aspects of Instrumentation Capability

Capacitor Driven Pulsed Magnets		
Magnet, Field (T), Bore (mm)	Duration FWHM (ms)	Supported Research
Cell 1, 65T, 15.5 mm	20	Magneto-optics (IR through UV), magnetization (susceptibility, extraction, and torque), and magneto-transport, (DC-MHz & GHz conductivity), Pulse Echo Ultrasound spectroscopy, Fiber Bragg grating dilatometry, all from 350 mK to 300 K. In-situ sample rotation and pressures up to 100 kbar are available for compatible techniques. IR & FIR transmission and FBG dilatometry in the Single Turn Magnet.
Cell 2, 65T, 15.5 mm	20	
Cell 3, 65T, 15.5 mm	20	
Cell 4, 65T, 15.5 mm	20	
Cell 294 Pulsed Power Test cell	N/A	
Bldg 125 Single Turn, 300T, 10mm	0.003	
Generator Driven Magnets		
Magnet, Field (T), Bore (mm)	Duration FWHM (ms)	Supported Research
100T Multi-Shot, 101 T, 10 mm	15	All techniques listed above including magnetothermal studies (heat capacity and magnetocaloric measurements) FIR and THz optics and larger sample volumes in the long pulse magnets.
60T Controlled Waveform, 60 T, 32 mm	100 (plateau)	

# Chapter 3 – User Facilities

PFF

The table above lists the pulsed magnets available to users of the NHMFL-PFF. The short pulse magnets serve the majority of users with maximum fields currently in the 65 tesla range. The 100T multi-shot magnet is the first and only magnet in the world to successfully perform a magnetic field pulse to 100 tesla in a non-destructive manner. The NHMFL pulsed magnets are arguably the best and most capable pulsed magnets in the world that are available to qualified users through the NSF-DMR supported user program.



**Figure 1:** The new Duplex magnet sitting on the floor in front of the duplex magnet cryostat is housed in building 294 and will allow routine pulses up to 75 tesla for users in 2017.

The expertise in pulsed power engineering and access to world-class materials scientists at both LANL and FSU focus attention on development and characterization of the best materials for magnets. The PFF at LANL is also home to the 60 T Controlled Waveform (A.K.A. “Long Pulse”) magnet which has the ability to customize pulse waveforms for optimal user research. The 300 tesla single turn magnet at the PFF (development and installation was funded by LANL) provides users with access fields in excess of 100T – routine pulses are to 170 tesla with a pulse duration of 6 microseconds. In addition to optical studies, including FBG dilatometry, the platform has recently been updated with an inductive contactless method enabling thin (~micron thickness conductors) to be studied at extremes of high magnetic fields.

PFF

## 7.2. Facility Developments and Enhancements

In 2017 the most significant facility enhancement was the completion of the new 75T Duplex magnet, consisting of two nested magnet coils driven by two separated cap-bank circuits, located in a new cell with two isolation switches and new user platform built next to our 4MJ Cap-bank. Since the new Duplex magnet will share the capacitor bank with our four 65T magnets, the switch system must be modified to minimize the effect of Duplex magnet operation on the performance of 65T magnets. The new switch components were received at the end of 2017 and are scheduled to be installed in the first quarter of 2018. In rare cases, one coil in the Duplex magnet is energized while the other remains in open circuit due to misfire. This situation can create very high induced voltages on the terminals of the open coil damage electronics or switches in the capacitor bank. To avoid this, a bank of Metal Oxide Varistor (MOV) as seen in **Figure 2** was designed, built, and tested. The MOV bank will be connected in parallel to the outer coil of the duplex magnet to prevent large induced voltages at the terminals of this coil.

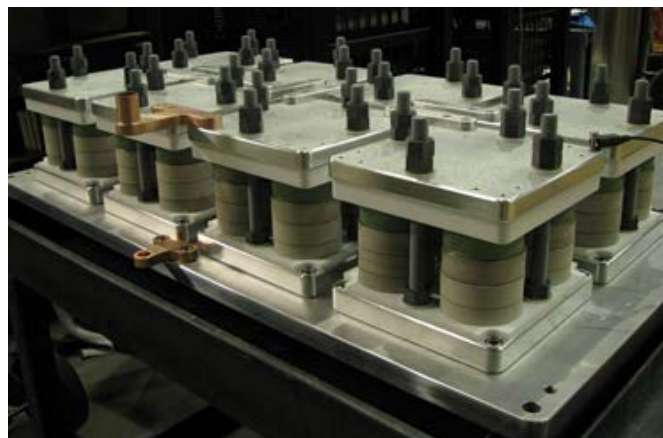

**Figure 2:** Metal Oxide Varistor designed to prevent large induced voltages at the terminals of the Duplex magnet.

A design phase for our 1.43 GW power generator upgrades, amounting to \$0.9M institutional support, was completed in 2017. This phase included Line Commutated Inverter (LCI) layout drawings, block diagram, design data, and signal interface list; a study of control upgrade from power supply rejection units (PSR)

# Chapter 3 – User Facilities

PFF

to protective electronic circuit (PEC); a 16kV upgrade study; Excitation System general layout, circuit diagram, and cable schedule. Also completed was the acquisition of four Fiber Optic Current Sensor (FOCS) systems, and payment for new control training at ABB center in Turgi, Switzerland.

## 7.3. Major Research Activities and Discoveries

The PFF continues to develop world-class experimental capabilities at the milli- to micro-second time scale as necessary in pulsed magnet fields. For example, the pulse echo ultrasound technique launched in 2016 by NHMFL-PFF scientist Brad Ramshaw was further improved and implemented in the NHMFL-PFF user program in 2017. With this method, elastic constants of a material can be measured that are directly related to thermodynamic key properties such as the compressibility, which allow the investigation of field-induced phase transitions and symmetry changes. The new hardware based on a fast 6Gs/sec digitizer card with 4Gs onboard memory has two main advantages compared to conventional signal mixing techniques, i) increased time resolution and ii) acquisition of one complete set of experimental data during the magnet pulse.

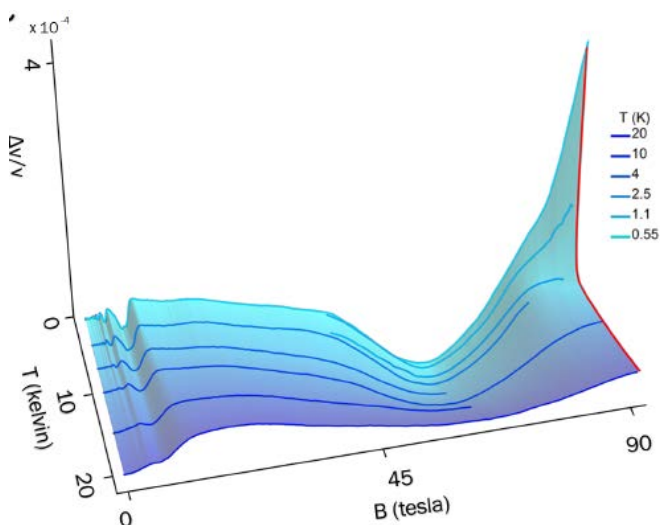

**Figure 3.** Measurements of the change of sound velocity  $\Delta v/v$  versus magnetic field  $B$  of the Weyl semimetal TaAs for the  $c_{33}$  modulus. The graph shows a combination of data taken in the 65T short pulse magnet and the 100T multi-shot magnet. The results are currently submitted for publication.

PFF

The data analysis is done afterwards without losing information by imposing certain parameters during the experiment. The necessary software package to handle and analyze this large set of recorded data was recently improved by FSU scientist Franziska Weickert to make it user-friendly in a LabView platform. **Figure 3** shows results obtained with the pulse echo ultrasound technique during an experiment in January 2017 on the Weyl semimetal TaAs.

During 2017, the development of a high resolution piezo-dilatometry technique was fielded on the 65T tesla magnet system by Xiixin Ding, with potential application to 100T. The new method provides high sensitivity and the ability to sense crystallographic directions normal to the applied magnetic field, complementing existing optical FBG dilatometry. The technique will be available to users in 2018 with close support from PFF scientists.

## 7.4. Facility Plans and Directions

The Pulsed Field Facility is gearing up for operation of the Duplex magnet system in 2018 (see figure 1). In Early 2017, a capacitor bank shutdown was implemented for updating of the operational software to allow for independent control of sections of the bank. The Duplex magnet is scheduled to be tested to deliver full magnetic field in summer 2018. Another major institutional investment from LANL (over \$1M) is aimed at the 1.43 GW generator facility in 2018. A contract between ABB and LANL to complete upgrades of the generator drive system as well as the exciter system is being finalized. These major improvements will allow for greater reliability and safety of this massive pulsed power system.

## 7.5. Outreach to Generate New Proposals-Progress on STEM and Building User Community

During 2017 the PFF hosted and participated in numerous outreach events including a Summer Physics Camp and the Los Alamos County ScienceFest. PFF scientists Shaline Chikara, Xiixin Ding, and FSU scientist Franziska Weickert volunteered in the inaugural Summer Physics Camp for Young Women hosted by the Pojoaque Valley High School. Participants included young women from ATC Charter School, St. Michael's High School, Pojoaque Valley High School, Capital High, Española Valley High School, Early College

# Chapter 3 – User Facilities

PFF

Opportunities, Santa Fe High School, and New Mexico Connections Academy. The camp included a tour of LANSCE (the Laboratory's neutron science center), the National High Magnetic Field Laboratory, and New Mexico Consortium's Biolab.



**Figure 4:** NHMFL-PFF Postdoc Shalinee Chikara at the Summer Physics Camp for Young Women, June 2017.



**Figure 5:** NHMFL-PFF scientist John Singleton demonstrates magnetism, coils, magnets, and magnet reinforcement shells to children at the Los Alamos County ScienceFest July 2017.

PFF

The NHMFL-PFF was pleased to sponsor the visit of LANL Director Charlie McMillan in 2017. In **Figure 6** NHMFL-PFF employee Yates Coulter gives Dr. McMillan a detailed and engaging description of our 1.43 GW power generator system.



**Figure 6:** LANL Director Charlie McMillan visiting the NHMFL-PFF, touring the motor generator building with motor generator operator Yates Coulter.

## 7.6. Facility Operations Schedule

The PFF has operated for four years now with a quarterly scheduling model and has solicited the quarterly call in concert with the DC facility. This schedule better serves users by securing availability of the PFF user support scientists. Hours of operation for large magnets energized by the 1.43 MW motor generator are from 8:00am – 5:00pm Monday through Friday. A 16KV 4MJ capacitor bank is used to drive the 65T short pulse magnets, 4 cells are equipped with these magnets and typically 3 are in use Monday – Friday 8:00am to 6:00pm on regular schedule, 6:00pm-11:00pm on extended after-hours schedule. Maintenance is scheduled each Monday 8:00am-10:00am, or performed on an as needed basis.



# Chapter 3 – User Facilities

PFF

PFF

## XY-nematicity in the heavy-fermion superconductor CeRhIn<sub>5</sub>

F. Ronning<sup>1</sup>, T. Helm<sup>2</sup>, K. Shirer<sup>2</sup>, M. Bachmann<sup>2</sup>, L. Balicas<sup>3</sup>, M. Chan<sup>3</sup>, B.J. Ramshaw<sup>3,4</sup>,  
R. McDonald<sup>3</sup>, F. Balakirev<sup>3</sup>, M. Jaime<sup>3</sup>, E.D. Bauer<sup>1</sup>, and P.J.W. Moll<sup>2</sup>

1. LANL; 2. Max-Planck-Institute for Chemical Physics of Solids; 3. NHMFL; 4. Cornell University

Funding Grants: G.S. Boebinger (NSF DMR-1157490); L. Balicas (DE-SC0002613); P. Moll (DFG MO 3077/1-1)

Electronic nematicity describes a state of correlated electrons in which a rotational symmetry of the crystal is broken by the onset of electronic correlations. We have detected a magnetic-field-induced nematic state in the heavy fermion superconductor CeRhIn<sub>5</sub>. Key to this collaborative project was the combination of highest quality crystals from LANL, the ion-beam microstructuring done at MPI-CPFS, and the high magnetic field facilities and expertise at the NHMFL.

Broken rotational symmetry due to electronic correlations can be detected by the sudden appearance of an anisotropy in the resistivity along crystalline directions that are symmetry-equivalent at low magnetic fields. We observe a 10-fold anisotropy between orthogonal tetragonal lattice directions at a transition field  $H^* \sim 28T$ . The nematicity can be generated by a small in-plane magnetic field component along any planar direction, without apparent connection to the underlying crystal lattice. As such, this is the first example of a nematic order belonging to the XY-universality class, as all previously-reported nematics are strongly Ising in character. This observation establishes electron nematicity as a common feature among three classes of superconductors: the cuprates, the iron-based, and the heavy fermions.

As such, nematicity is now believed to be strongly intertwined with the existence of high-T<sub>c</sub> superconductivity. CeRhIn<sub>5</sub> offers the unique possibility of directly tuning from nematic order to a *d*-wave superconducting phase via pressure and magnetic field, thus establishing a clear connection between these two correlated electronic states. This raises the likelihood in many physicists minds that electron nematicity promotes high-temperature superconductivity.

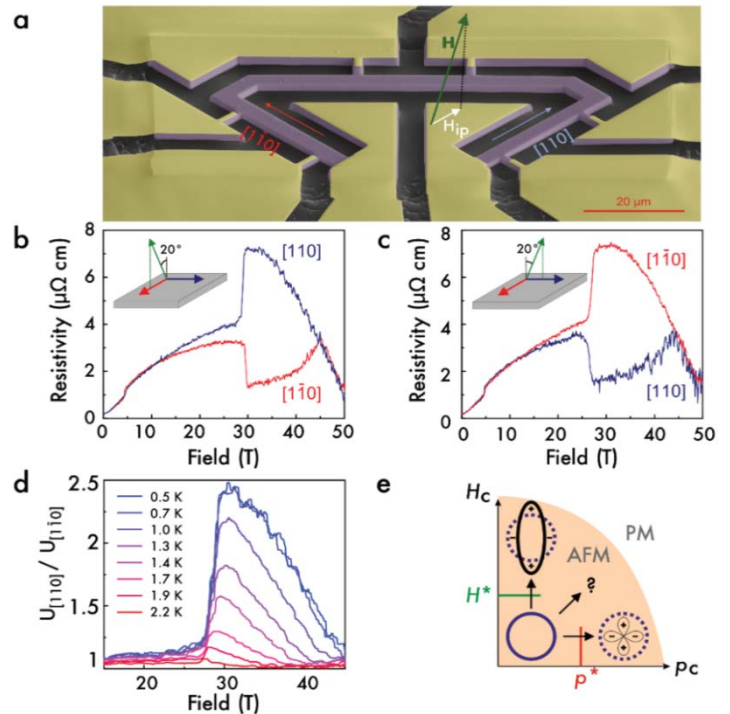

(a) Microstructure of the resistance bridge micro-machined in the CeRhIn<sub>5</sub> sample. (b,c) sudden appearance of a nematic phase at  $H^* \sim 28T$ , evidenced by an in-plane anisotropy in the resistivity. (d) temperature dependence of the nematic phase transition. (e) tentative phase diagram connecting nematicity (vertical arrow thru  $H^*$ ) and *d*-wave superconductivity (horizontal arrow thru  $p^*$ ).

**Facilities:** DC Field: 35T resistive, 45T hybrid. Pulsed: 65T, 100T

**Citation:** F. Ronning, T. Helm, K.R. Shirer, M.D. Bachmann, L. Balicas, M.Chan, B.J. Ramshaw, R. McDonald, F. Balakirev, M. Jaime, E.D. Bauer, and P.J.W. Moll.

Electronic in-plane symmetry breaking at field-tuned quantum criticality in CeRhIn<sub>5</sub>, Nature (2017) doi:10.1038/nature23315

# Chapter 3 – User Facilities

PFF

PFF

## Upper critical field reaches 90 teslas near the Mott transition in alkali-doped fulleride superconductors

Y. Kasahara<sup>1</sup>, Y. Takeuchi<sup>2</sup>, R.H. Zadik<sup>3</sup>, Y. Takabayashi<sup>4</sup>, R.H. Colman<sup>3</sup>, R.D. McDonald<sup>5</sup>,

M.J. Rosseinsky<sup>6</sup>, K. Prassides<sup>4,7</sup> & Y. Iwasa<sup>2,8</sup>

<sup>1</sup> Kyoto University, Japan <sup>2</sup> QPEC & University of Tokyo, Japan <sup>3</sup> Durham University, UK <sup>4</sup> WPI-Tohoku University, Japan

<sup>5</sup> NHMFL, LANL USA, <sup>6</sup> University of Liverpool, UK <sup>7</sup> JST-Tohoku University, Japan <sup>8</sup> RIKEN –CEMS, Japan;

Funding Grants: G.S. Boebinger (NSF DMR-1157490);

The alkali-doped fullerides provide the first example of a transition from a three-dimensional Mott insulator to a superconductor, enabling the effects of both dimensionality and electron correlations on superconductivity to be explored. Chemically, the alkali species tunes the superconductivity in the vicinity of the Mott transition by varying the unit cell volume.

Measuring the relationship between the superconducting transition temperature,  $T_c$ , and upper critical magnetic field,  $H_{c2}$ , revealed a crossover from weak- to strong-coupling as the Mott transition is approached, a crossover associated with the dynamical Jahn–Teller effect. The use of pulsed magnets is required because the upper critical field is enhanced in the vicinity of the Mott insulating phase, reaching 90T for  $Rb_xCs_{3-x}C_{60}$  — the highest among cubic crystals. This required close collaboration between external users and MagLab scientists to design radio frequency (rf) measurements compatible with sample encapsulation in an inert atmosphere.

The increase of pairing strength with lattice volume near the Mott transition suggests that a cooperative interplay between molecular electronic structure and strong electron correlations reinforces the robust superconductivity (high- $T_c$  and high- $H_{c2}$ ) found in the alkali-doped fullerides.

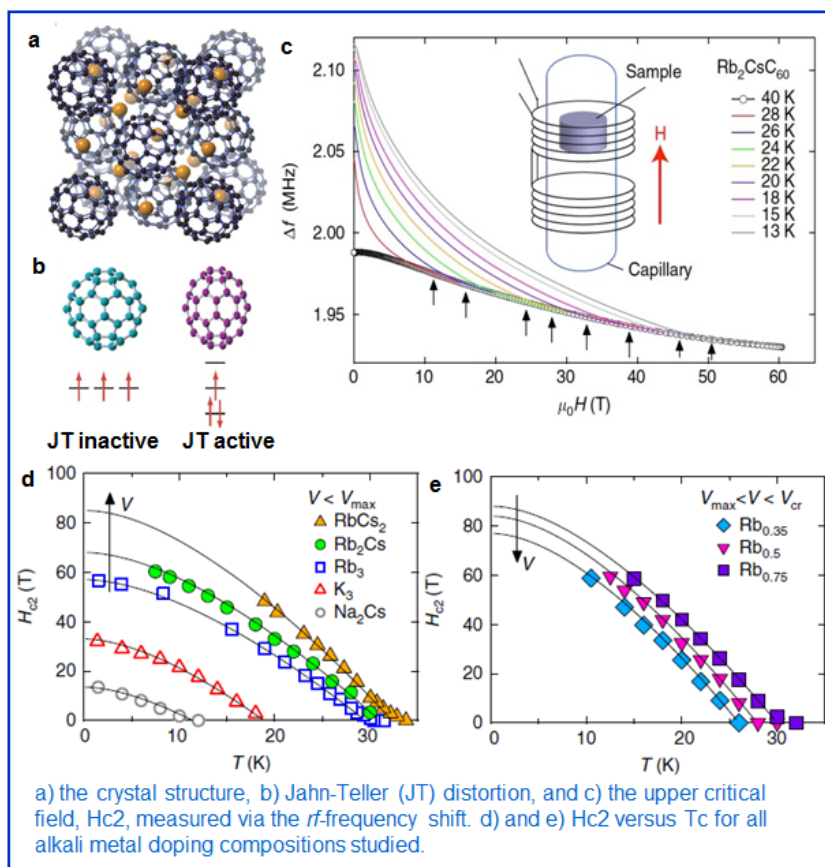

**Facilities:** Pulsed Field Facility, short pulse magnet systems.

**Citation:** “Upper critical field reaches 90 Tesla near the Mott transition in fulleride superconductors” Y. Kasahara, Y. Takeuchi, R.H. Zadik, Y. Takabayashi, R.H. Colman, R.D. McDonald, M. J. Rosseinsky, K. Prassides and Y. Iwasa – **Nature Communications** 8, 14467 (2017).



# Chapter 4 – Education and Outreach



# Chapter 4 – Education and Outreach

## Education and Outreach

In 2017, the Education and Outreach efforts of the MagLab continued to reach thousands of students and members of the general public at all three sites and across the nation through outreach demonstrations in Washington D.C. and our website. As always, the Center for Integrating Research and Learning (CIRL) worked closely with Public Affairs to continue our mission to expand scientific literacy and to encourage interest in and the pursuit of scientific studies among educators and students of all ages. CIRL continues to evaluate our educational programs so that we can ensure that our programs are meeting our goals to excite and educate students, teachers, and the general public about science, technology, and the world around them.

Highlights from our 2017 Education and Outreach Efforts were:

1. The Public Affairs team partnered with the FSU College of Film to create a custom virtual reality experience that was showcased at the Smithsonian Museum of American History in October

### 1. K-12 STUDENTS

#### 1.1. On-Site and Classroom Outreach Conducted Through CIRL

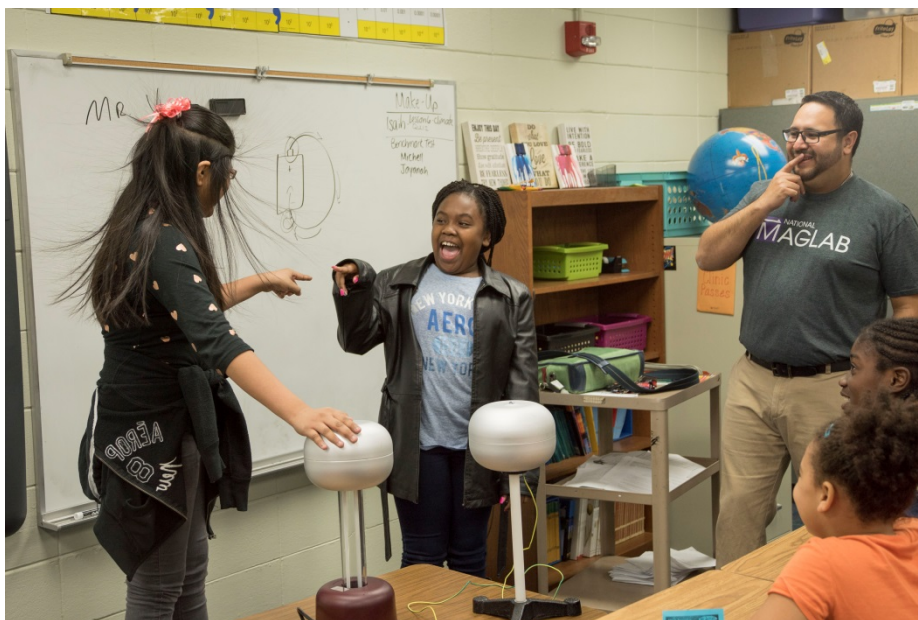

2017 Classroom Visit

CIRL staff and MagLab scientists conduct outreach in local schools each year. The outreach is recorded according to the school year as opposed to the calendar year. During the 2016-2017 school year

connected to the *ACcelerate Festival of Innovation and Creativity*.

2. The MagLab hosted a movie-themed *Open House* that reached over 8,000 people.
3. The inaugural *SciGirls Coding Camp* was held in summer. This camp was the MagLab's response to the lack of representation of girls and women in the computer and technology fields. This camp met its goal of exposing participating youth to a variety of career options in these fields and increase their interest in computing.
4. Scientists and staff at LANL and UF committed to outreach programs that aimed to increase the representation of girls in STEM through their *Expanding Your Horizon Conference* and *Spring Break Camp* for girls, respectively. In addition, UF hosted an event with MagLab panelists for the *UN International Day of Women and Girls in Science* to inform members of the public of opportunities for women and girls in STEM fields.

CIRL's Director of K-12 Programs, Carlos Villa, and CIRL Educational Intern, Haley Reid, provided outreach to over 10,000 students from school districts in Northern Florida and Southwest Georgia. Title I schools made up the bulk of these visits, accounting for 41 of the 59 school visits (69%). CIRL continued to offer 12 types of outreach activities. The most popular activities were the *Build an Electromagnet*, *the Nature of Science* (Observations & Inferences), and the *Static & Current Electricity* activities. (For more information on the activities listed and all of CIRL's outreach activities, please visit the outreach website

at <https://nationalmaglab.org/education/teachers/classroom-outreach>). Elementary school students represented 63% of the visits, followed by middle school students (32%) and high school students (5%). On evaluation surveys, teachers reported learning about the MagLab's outreach programs from colleague

# Chapter 4 – Education and Outreach

communication (33.3%), the MagLab website (26.7%), and from MagLab staff (16.7%).

At the MagLab's UF facility, Elizabeth Webb conducted outreach efforts during the school year. Elizabeth and fellow UF personnel reached 975 students through classroom outreach 84% of these were Title I schools. Carlos trained UF personnel in 6 of the outreach activities, up from 4 the previous year. In 2017, the *Build an Electromagnet* lesson was the most frequently requested lesson. The *Magnet Exploration* lesson and the *What is Science* lessons were tied for the next most popular. Approximately 60% of these outreach lessons were presented to Alachua Public Schools elementary students, with the remaining 40% of the presentations being to Alachua Public Schools middle school students. Additionally, Elizabeth coordinated activities to summer camps, afterschool programs, and

school-wide science nights, reaching an additional 722 elementary and middle school students through those efforts.

The staff at LANL also conducted outreach in local schools. Dr. Laurel Winter Stritzinger has developed an outreach lesson using what was offered at the MagLab in Tallahassee and adapting it to the unique science at LANL. The LANL staff has reached nearly 350 students, almost all of them elementary students. They also participated in several programs aimed at increasing girls' interest in STEM careers, working with over 200 students as part of the *Expanding Your Horizons* conference which took place in October. The conference focuses on exposing 5th - 8th grade girls to STEM careers and female role models in STEM and was held in Santa Fe, NM.

## 1.2. Middle School Mentorship

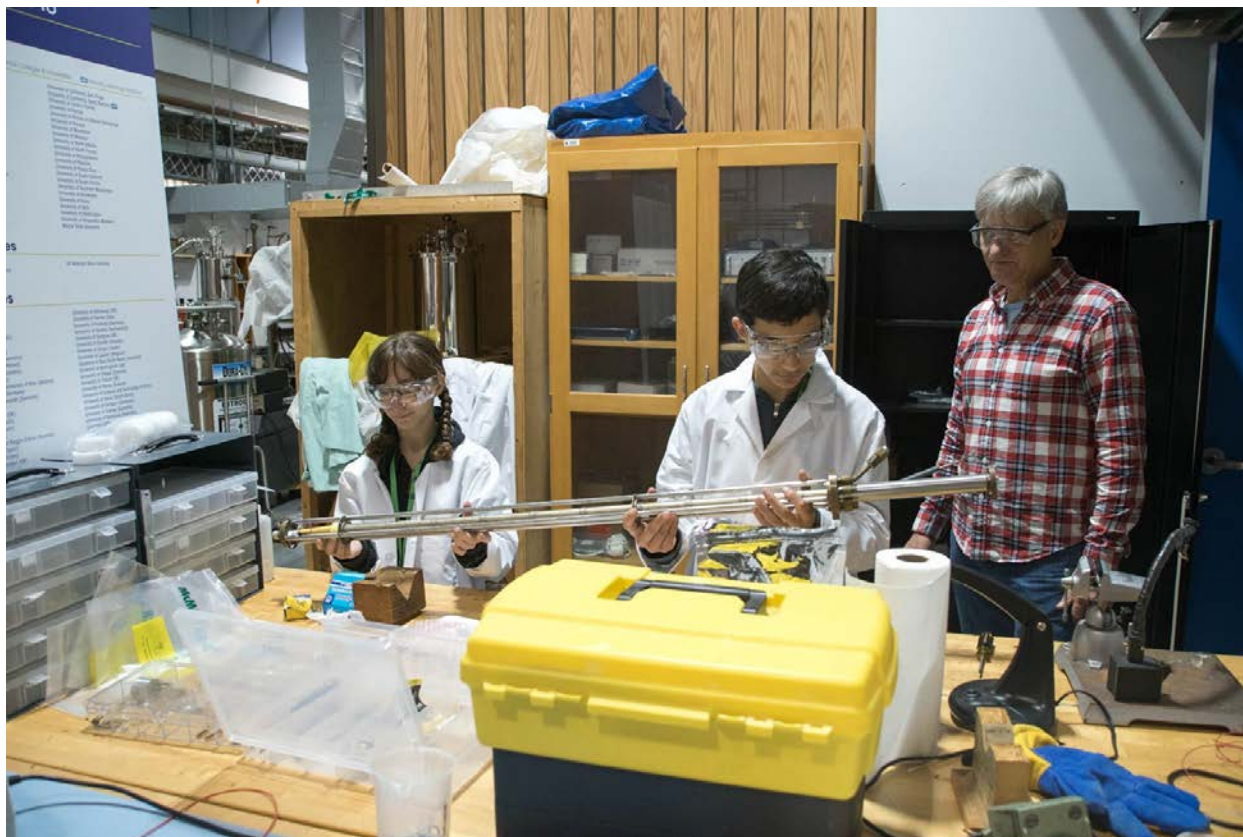

Two middle school students working with their mentor Hans van Tol.

The MagLab Middle School Mentorship Program hosted its largest group for the third consecutive year. In 2017, the program included 20 students from middle schools in Leon & Gadsden Counties. These stu-

dents worked with 13 MagLab scientist mentors: Ernesto Bosque, Yu-Chieh Chi, Lloyd Engel, Wei Guo, Nathaniel Garceau, Chen Huang, Jennifer Neu, Patrick Noyes, Dmitry Smirnov, Vince Toplosky, Hans VanTol

# Chapter 4 – Education and Outreach

Bob Walsh, and Gary White. The students meet their mentors every Friday morning in lieu of school, and do so for the entire fall semester. The program culminates in a poster presentation session attended by their family, teachers, principals, and mentors. This year's class

was comprised of 50% underrepresented minority groups in STEM including: 5 African American students (1 male and 4 female), 4 Hispanic students (2 male and 2 female), 1 female American Indian student, 1 Asian American female, and 3 Caucasian female students.

**Table 1: 2017 Middle School Mentorship Participants and Projects**

Participant	School	Research Area	Mentor
<i>Ian McFarlin</i> <i>Paloma Rambana</i>	Trinity Catholic School Maclay School	Building a Magnetic ID Reader	Ernesto Bosque
<i>Ananda Chaterjee</i> <i>Alexandro Valdez</i>	<i>Fairview Middle School</i> <i>Deerlake Middle School</i>	Independently Functional Magnetic Train	Lloyd Engel
<i>Srividya Donthineni</i> <i>Angeleena Jackson</i>	<i>Fairview Middle School</i> <i>Raa Middle School</i>	Resistance Change with Temperature	Wei Guo & Nathaniel Garceau
<i>Asya Adderson</i> <i>Mary Jane Summerlin</i>	<i>Florida A&amp;M DRS</i> <i>Fort Braden School</i>	Micro Dynamic Using Density Functional Theory	Chen Huang & Yu-Chieh Chi
<i>Jevaughan Brown</i> <i>Mahets'i Martinez</i>	<i>Fairview Middle School</i> <i>Crossroads Academy Charter School</i>	Rochelle Salt: Piezoelectric and Pyroelectric Properties	Jennifer Neu
<i>Janelle Cripe</i> <i>Farzan Shiju</i>	Montford Middle School <i>Fairview Middle School</i>	1D Cyclotron Analog	Patrick Noyes
<i>Zita Boutin-Johnson</i> <i>Oliver Holden-Schrock</i>	<i>Fairview Middle School</i> Cornerstone Learning Community	Calibration and Use of a Confocal Microscope	Dmitry Smirnov
<i>Abigail Martin-McKinnie</i> <i>James David Milford</i>	Cornerstone Learning Community Maclay School	Three Mystery Metals Identified	Vince Toplosky & Bob Walsh
<i>Catharine Tew</i> <i>Elan Wygodski</i>	Cobb Middle School Swift Creek Middle School	Coffee Beans and Free Radicals	Han Van Tol
<i>Nirmay Bhanderi</i> <i>Karen Salazar-Angeles</i>	Maclay School <i>Nims Middle School</i>	Arduino Dust Sensor	Gary White

**Note:** Schools in italics are Title-1 schools

### 1.3. Summer Programs

In 2017, CIRL housed five middle school summer camps (Summer Camp TESLA 1 and 2, SciGirls 1 and 2, and SciGirls Coding Camp) reaching over 100 students. Carlos Villa oversees all of the summer camps and supervises the camp teachers.

### 1.4. Camp Tesla

In 2017, the MagLab Summer Camp was renamed *Camp TESLA* (Technology, Engineering, & Science in a Laboratory Atmosphere). Camp TESLA is a one-week coed summer camp held every June for boys

and girls interested in science. The camp activities are planned by camp teachers and highlight MagLab science and engineering research and/or disciplines. There are two identical sessions offered in back-to-back weeks. In 2017, 48 students participated in one of the two one-week sessions. 48% of the campers were female, 31% of the campers were African American, and 13% were Hispanic. Post camp evaluation surveys indicated that participants cited the following activities as positively changing their views of science and engineering: building speakers from household materials, the design and construction of chaos towers, and the MagLab tour.

# Chapter 4 – Education and Outreach



*Camp Tesla youth making calculations*

## *1.5. SciGirls Summer Camp*

In 2017, SciGirls Summer camp completed its 12<sup>th</sup> year. This program is based on a partnership be-



*SciGirls Campers building bridges*

tween the MagLab and our local public television station, WFSU. The program is closely associated with the SciGirls Connect program, an NSF funded national SciGirls Program associated with Twin Cities Public Television. The camp includes two two-week camps for middle school girls. 47 girls participated in SciGirls Summer Camp in 2017, 23% of whom were African American, 9% were Hispanic/Latina, and 2% were Native American. Based on post survey responses, the girls cited the following as the activities that positively influenced their views of STEM: creating a virtual reality game with the Florida Center for Interactive Media, a psychology course and neural pathways activity at FSU, and a chemistry activity with MagLab scientist Dr. Amy McKenna, along with meeting women scientists throughout the camp who served as role models including many from the MagLab.

## *1.6. SciGirls Coding Camp*

Seizing upon the growing popular culture interest in technology and the lower representation of girls and women in these fields, CIRL added a technology focused SciGirls Coding Camp in 2017. Fifteen middle school girls participated in this one week program where they learned the basics of computer programming. They developed projects such as coding with Spheros, and robotics coding with guest speaker Desiree Fraser of Diverse Computing, Inc. Post camp survey responses indicate that all of the participants mentioned how the camp helped them to realize their talents and connect those to computer programming.



*SciGirls Coding Campers with their Ozobots*

# Chapter 4 – Education and Outreach

## 2. K-12 TEACHERS

### 2.1. Leon County Schools Workshop



*Leon County teachers at the 2017 workshop*

In 2017, the Leon County Schools district was awarded an AT&T grant to develop a STEAM Bowl Challenge in all of the districts' elementary schools. CIRL staff members, Jose Sanchez and Carlos Villa, worked closely with the PI on the grant and the elementary teachers. The program began with a workshop in January 2017. Jose and Carlos facilitated a workshop that helped teachers understand how to incorporate engineering and art concepts and problem-solving activities in their classrooms and clubs. Then throughout the 2017 spring semester, they were available to answer questions as each elementary school club prepared for the culminating event - the STEAM Bowl Challenge. This year there were four challenges: a science communication challenge, a boat building challenge, an elimination of noise challenge, and the design and creation of a robot powered by a DC motor and 9V battery. Twenty-three schools participated in the STEAM Bowl Challenge, resulting in 115 students and over 30 teachers and administrators reached by the program. The teachers credited the success of the STEAM challenge to CIRL's dedication to the project. This partnership is further evidence of CIRL and the MagLab's commitment to education in Leon County.

### 2.2. Research Experiences for Teachers (RET)

The 2017, the RET program hosted 10 teachers (four elementary school and six secondary school) from seven different counties in Florida and

two out of state teachers from Louisiana and North Carolina, respectively. This program is run by Director of RET, REU, and Internships, Jose Sanchez. A large part of the success of this year's program is due to the five wonderful mentors that worked closely with the teachers over the 6 weeks. In 2017, 80% of the teachers came from Title I schools, 10% were African American and 20% were Hispanic. A list of the participants and their projects can be found at <https://nationalmaglab.org/education/teachers/professional-development/research-experiences-for-teachers/ret-archives/ret-2017>

Based on the post-survey evaluation, Jose plans to make the following changes in 2018:

- Have more guest speakers from the Lab give talks on their research
- Pair teachers by teaching level (e.g. elementary school teachers with elementary school teachers and high school teachers with high school teachers)
- Require mentors to provide a syllabus to the RETs prior to their arrival

The teachers indicated that these changes would have improved their experience, although evaluation reports indicated that all were very satisfied with the program and its impact on their understanding of scientific research.



*2017 RET participants*



# Chapter 4 – Education and Outreach

## 2.3. MagLab Educators Club

The MagLab Educators Club is an email list that CIRL utilizes to send information about MagLab community events, outreach, programs, and other exciting opportunities at the Lab. We have over 300 members, providing further evidence of the interest of educators in MagLab programs.

## 2.4. Magnet Academy – For Teachers

The Magnet Academy is the outreach portion of the MagLab's website. This site has a page that focuses on teachers (<https://nationalmaglab.org/education-magnet-academy/teachers>). This page provides lesson plans, science demonstrations, and interactive activities for teachers of students of all ages.

## 3. PUBLIC AFFAIRS

In collaboration with Public Affairs, the MagLab also expanded its outreach efforts to the public in 2017. The Public Affairs team, under the direction of Kristin Roberts, uses a wide variety of communications tools to share scientific news with the MagLab's diverse audiences:

### 3.1. News releases

In 2017, the Public Affairs team wrote nearly **20 news releases** that generated more than **3,780 media mentions** reaching **1,181,689,280 people**. Media coverage generated around the launch of the new Project 11 magnet in August earned over **350 media articles** (and counting) including in publications like the **Washington Post, Boston Herald, Los Angeles Times, NY Daily News** and the **Daily Mail** and reaching nearly **250,000,000 people**.

### 3.2. Website

In 2017, the website continued to grow with more than 1.1 million pageviews, an increase of 13% over 2016. The pageviews were divided throughout key content areas around the site. Sections of the site, by

percentage of all pageviews, January to December 2017:

- Education: 45%
- Homepage: 13%
- User Facilities: 10%
- Personnel and Publication databases: 6%
- News/Events: 6%
- Research: 5%
- Staff: 5%
- About: 4%
- Magnet Development: 4%
- User Resources: 2%

In addition, the website saw growth in sessions, users and traffic:

- Number of sessions up 31%
- Number of users up 41%
- Percentage of *new* users up from 66% of all users to 70% of all users
- Percentage of users on a tablet or other mobile device: up from 17% of all users to 23% of all users
- Organic search traffic is up 59%, indicating better performance of site content in search engines
- Number of pageviews to Magnet Academy up 10%

### 3.2. Social Media

In 2017, the MagLab's online presence continued to expand through the use of social media. Our **Facebook** page saw a 26% growth, with fans almost evenly split between male (50%) and female (49%). The page is most popular with people between the ages of 24 and 44, with 25-34 year old males making up the largest percentage of our audience. Most of the Lab's Facebook fans are from the United States, but our followers also come from more than 40 other countries including these ten who have the most followers: India, Brazil, Pakistan, Egypt, Mexico, Bangladesh, Canada, Turkey, France, and the United Kingdom.

# Chapter 4 – Education and Outreach



**Figure:** Facebook followers increased from 2223 to 2803 in 2018.

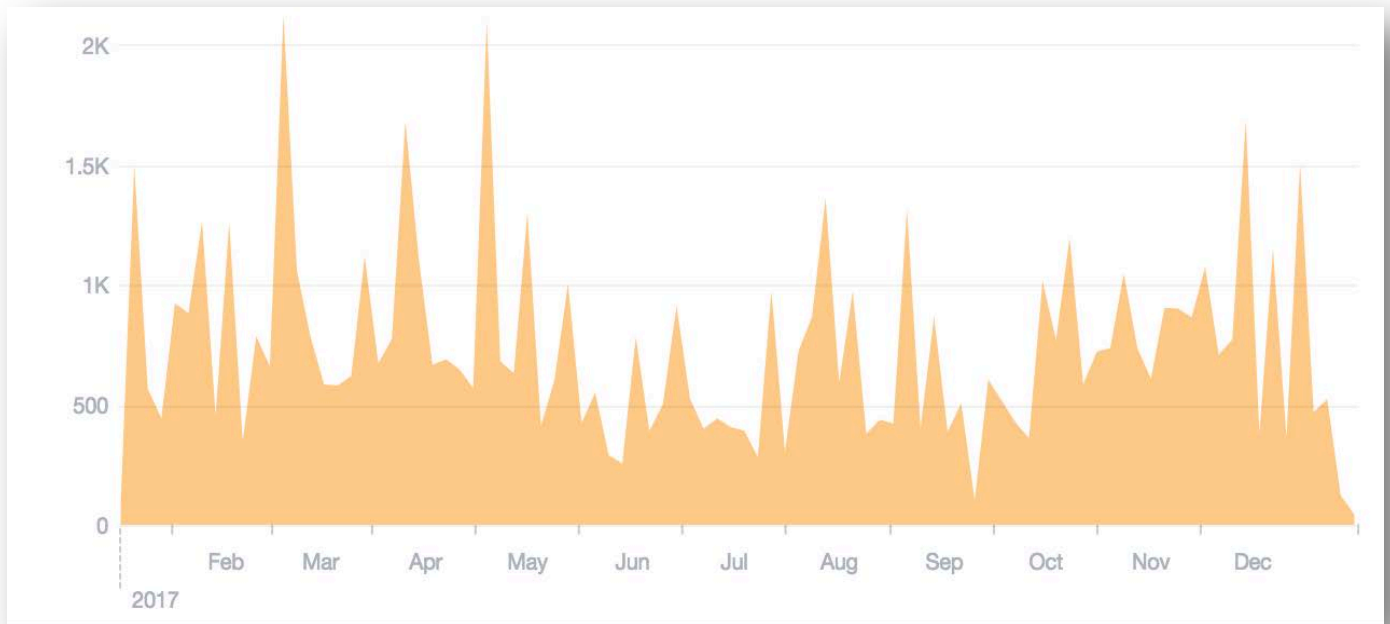

**Figure:** Facebook post reach – or the number of people who saw posts by or about your page - throughout 2017.

Our **Twitter** page earned 1,992 followers in 2017. The Lab’s Twitter followers are mostly male (62%) and almost half of our audience is between the age of 25 and 34. About 40% of our Twitter audience identifies their occupation as professional/technical. A single tweet about the new 41 tesla resistive magnet world record earned nearly 40,000 impressions in August: *While the country watched the solar eclipse, our engineers pulled off an eclipse of a different sort:* [ow.ly/1oPB30eAVyK](http://ow.ly/1oPB30eAVyK)

**Instagram** nearly doubled in followers with 420 and our Pinterest page reaches about 1,888 people each month.

The Lab’s **LinkedIn** company page added 250 followers in 2017. Our LinkedIn followers are predominantly from the research and higher education sectors. In 2017, more followers came from the biotechnology, mechanical, and electrical engineering sectors.

# Chapter 4 – Education and Outreach

## 3.3. YouTube

The MagLab has had an active **YouTube** page since 2008. From 2016 to 2017, the channel's subscribers skyrocketed to 23,075. The number of views increased 23 fold to 1,074,506 and watch time increased 22 fold to 2,260,455 minutes watched. Shares of

our YouTube videos increased 20 fold to 6,892; likes increased 57 fold to 10,647. The age group that grew the most was 18-24 year olds, from 16% to 26% of all watch time minutes.

**Table 2:** YouTube trend data

	2016	2017	Difference	Difference
Views	56,534	1,074,506	1,017,972	1,801%
Watchtime	97,237	2,260,455	2,163,218	2,225%
Subscribers	113	23,075	22,962	20,320%
Videos added to playlists	304	15,366	15,062	4,955%
Likes	182	10,647	10,465	5,750%
Average View Duration	103	126	23	22%
Shares	317	6,892	6,575	2,074%

**Table 3:** New videos added in 2017

Video	Date	Views
<i>Behind the New World Record Superconducting Magnet</i>	12/12/17	18,000
<i>MagLab Science Café: Boot Camp for Metals that Make the Cut in High-Field Magnets</i>	12/11/17	540
<i>MagLab Science Café: No Girls Allowed: Breaking down the barriers that keep women out of science</i>	10/5/17	391
<i>Classroom Kit: Magnet Exploration</i>	8/29/17	271
<i>Classroom Kit: Electromagnetism</i>	8/29/17	337
<i>Take 2 for Science: Jim Cleaves</i>	8/7/17	151
<i>Science in a Sentence: Condensed Matter Physics</i>	7/18/17	198
<i>See thru Science: How Capacitors Work</i>	4/24/17	779,198
<i>See thru Science: The Lorenz Force</i>	4/24/17	41,000
<i>See thru Science: How DC Motors Works</i>	4/24/17	14,000
<i>MagLab Science Café: Predatory Bacteria</i>	4/20/17	133
<i>National MagLab Open House 2017: Celebrating the Drama, Comedy &amp; Mystery of Science</i>	3/27/17	132
<i>See thru Science: How Ignition Coils Work</i>	2/28/17	141,740
<i>See thru Science: What Oersted Discovered with his Compass</i>	2/28/17	6,900
<i>See thru Science: How Van De Graaff Generators Work</i>	2/28/17	15,311
<i>See thru Science: How Electromotive Force Works</i>	2/28/17	352,932
<i>See Thru Science: How Microwaves Work</i>	2/28/17	41,444
<i>Winter Theory School – a collection of 12 videos</i>	1/24/17	1,553

## 3.4. Science Café

The MagLab's Science Café series continued in 2017 with quarterly Cafés. The Cafés were also video recorded, posted on the MagLab's YouTube channel,

and shared via social media, allowing this local series to have a broader impact than just the Tallahassee geographic area.

# Chapter 4 – Education and Outreach

**Table 4:** MagLab’s Science Café

Topic	Speaker	In person attendees	Youtube views
<b>4/19/17:</b> <i>Predatory Bacteria</i>	Huan Chen	65	133
<b>8/29/17:</b> <i>No Girls Allowed: Breaking down the barriers that keep women out of science</i>	Roxanne Hughes	80	391
<b>12/5/17:</b> <i>Boot Camp for Metals that Make the Cut in High-Field Magnets</i>	Bob Walsh	75	540

### 3.5. Fields Magazine

In 2017, the MagLab launched a brand new magazine called *fields*. The goal of the biannual publication is to communicate across disciplines to both scientists and science fans about the cool discoveries that can be made using high magnetic fields. Featuring research and tools from the National MagLab, the magazine’s broader scope also embraces research done at other magnet Labs in the world. This was done in a strategic effort to increase the magazine’s reach and impact and to build bridges within the community of high magnetic field researchers worldwide. The magazine is advised by an advisory committee that includes scientists and engineers from the MagLab as well as other institutions.

The magazine is distributed to MagLab users, stakeholders (funding agencies, lawmakers, community leaders, related industries), members of the science media, and the science-interested general public. About 2,600 physical copies are mailed to domestic subscribers (it is free to subscribe), and several hundred more are mailed internationally and via campus mail. In addition, thousands are distributed throughout the year at relevant scientific conferences and meetings and at MagLab events, including Open House. The magazine has its own website ([fieldsmagazine.org](http://fieldsmagazine.org), a subsite of [NationalMagLab.org](http://NationalMagLab.org)) which received 5,498 pageviews in 2017. A list of email subscribers (about 3,300) receive email notifications of new issues.

### 3.6. Open House

More than 8,000 visitors came to experience the drama, comedy, and mystery of science and the movies at the National MagLab’s world-class research Laboratory and take part in the nearly 100 fun, hands-on science demonstrations during Open House on February 25, 2017.

We rolled out the red carpet for *science* at Open House. Visitors came from around the Southeast, including Panama City, Daytona, Valdosta, and Dothan. This year’s Open



House explored science and the movies with a partnership with the FSU Film School who took visitors behind (and inside) the camera with virtual reality experiences and green screens.

Over 200 attendees completed either an online or paper survey. Survey respondents represented a wide range of income levels and zip codes. People came from 3 different states (Florida, Georgia, and South Carolina) and as far north as the Columbia, SC metro area and as far south as the Miami area.

45.5% of survey attendees visited the Lab for the first time this Open House, and this was the first Open House attendance for 51.5 % of survey respondents. Additionally, 22% of survey respondents had not heard of the MagLab prior to attending their

**Table 5:** Income Range Represented Among Open House Attendees

	Number	Percent
Less than \$30,000	19	9.8%
\$30,000 to \$49,999	16	8.3%
\$50,000 to \$69,999	34	17.6%
\$70,000 to \$99,999	31	16.1%
\$100,000+	44	22.8%
Prefer not to Respond	49	25.4%
<b>Total</b>	<b>193</b>	<b>100.0%</b>

# Chapter 4 – Education and Outreach

first Open House. Of those who had attended Open House previously, 44% indicated they had been to Open House once before, 8 indicated they had been twice, 4 indicated they had been 3 times, 6 had been to Open House 5 times before, one had been 10 times, and one had been 20 times.

Before Open House, respondents rated the Lab at an average score of 8.09 for a net promoter score of 33.15. After attending Open House, respondents rated the Lab at 9.54 for a net promoter score of 88.59.

Open ended survey responses and social media feedback reinforce the impact of this one-day event on our target audience

- Overall great information and amazing employees. Go MAGLAB!
- I love all the experiments and information that the MagLab provides
- This place is Awesome!
- Everyone should go to see the things being done there.

### 3.7. ACCelerate Festival

The MagLab participated in the first ACCelerate: ACC Smithsonian Creativity and Innovation Festival on October 13-15, 2017, at the National Museum of American History in Washington, D.C. The festival was a celebration of creative exploration and research happening at the nexus of science, engineering, arts and design (SEAD) and featured performances, conversations, and 48 interactive installations from across the 15

ACC schools. The MagLab brought a custom virtual reality experience that was created in partnership with the FSU Film School. The experience empowered participants to become a scientist and conduct a short experiment in the world's strongest magnet, all in virtual space.

### 3.8. Senior Center

The MagLab hosted a half-day experience on November 15, 2017 for several dozen visitors aged 65 or older in partnership with the Tallahassee Senior Center. These retirees built their own magnets, had a com-



prehensive tour, & learned about our research at a panel discussion with scientific experts. The event gave them a richer understanding of how electromagnets work, what the MagLab is, and the groundbreaking materials, energy, and life-related discoveries made here.



# Chapter 4 – Education and Outreach

## 3.8. Presentations in 2017

In addition to these many forms of outreach, CIRL staff also present at conferences for teachers and the general public to inform them about our programs and the educational research conducted at the MagLab. The 2017 educational outreach presentations included:

- C. Villa (March 2017). *Tesla Tales: Take a journey through the history of electromagnetic discovery*. Presentation at the National Science Teacher Association Conference, Los Angeles, CA.
- R. Hughes (April, 2017). *Long term programs over the long term: A longitudinal identity trajectory investigation of young women participating in a SciGirls summer camp*. Paper presentation at the Annual National Association for Research in Science Teaching (NARST) conference.
- K. Roberts (April 2017) *Effects of STEM Self-Efficacy on STEM Identity in a Middle School Girls' Summer Science Camp*. Roundtable Presentation at the annual meeting of the American Educational Research Association.
- K. Roberts (April 2017) *STEM Identity Growth in Co-Ed and Single-Sex Science Summer Camps*. Poster presentation at the annual meeting of the American Educational Research Association.
- C. Villa (October 2017) *Florida's Tesla Tale. Florida leads the world in electromagnet research. Come learn how Florida got the world's strongest magnet and what we do to keep that record here*. Presentation at the Florida Association of Science Teachers, Orlando, FL.
- C. Villa (October 2017) *The National Magnet Lab Talks About Magnets. The ultimate session on magnetism for elementary teachers*. This session covers magnets, their properties, and lesson ideas for your classroom.

## 4. UNDERGRADUATE, GRADUATE, AND POSTDOCS

### 4.1. MagLab Internship Program (For students 17 years or older)

Over the last five years the MagLab's internship programs have grown in recognition throughout Florida State University's STEM students and students from Leon County's local high schools. Jose Sanchez directs this program and facilitates MagLab scientists' selection of student interns each semester. In 2017, the students worked as volunteers in an unpaid position throughout the academic year. Mentors often offer some of these successful students paid positions over the summer.

The 2017, internship program hosted 35 high school and college students, of these: 40% were female, 14% were African American, and 5% were Hispanic. Jose plans to work towards increasing the diversity of the participating interns in 2018. Based on the post program survey recommendations, Jose plans to make the following changes in 2018:

- Summer interns will be invited to participate in the professional development and science presentations that are scheduled for REU
- To better match students with mentors, mentors will be required to write a job description of what they will have the intern do if they are hired for their department. This will allow Jose to pinpoint who is interested in working with an intern and also identify the intern with similar interest.

### 4.2. Undergraduate – Research Experiences for Undergraduates (REU)

The 2017, REU cohort hosted 18 undergraduates, of these students: 44% were female, 22% were African American, 22% were Hispanic, and 11% came from Minority Serving Institutions. All of the 2017 participants and their projects can be found at <https://nationalmaglab.org/education/college-students-early-career-scientists/reu/reu-archives/reu-2017>. Based on the post-program survey, Jose plans to make the following changes in 2018:

- REU students indicated that they would like to tour each other's Labs similar to the RET program "Weekly Lab Crawls". Jose will include this in the 2018 REU schedule.



2017 REU Participants

# Chapter 4 – Education and Outreach

- Jose realized the importance of the 2 focus groups he conducts with the REUs each summer. This gives him immediate feedback and allows him to make changes or address issues during the program. He will add two more in 2018 at the request of past participants who indicated the need for these.
- Mentors will be required to write a syllabus for the 10 weeks of the program

## 4.3. Graduate Students and Postdocs

Kari Roberts currently serves as the Director of Evaluation and Postdoc Liaison for the MagLab. She is available at any time to provide support to graduate students and postdocs to help them maximize their experiences at the Lab. In 2017, postdocs have continued to seek her assistance to find travel funding and to connect to MagLab and FSU campus resources. She also offers an individual welcome/ orientation for any new postdoc who is interested in receiving a customized welcome to the Lab.

**Table 6:** Seminars offered

Session Topic	Date	Presenter	Attendance (Postdocs)
<i>Advanced Literature Searching</i>	February 8, 2017	Kelly Grove	3 (1)
<i>Staying on Top of the Literature</i>	February 23, 2017	Julia Cater	4 (0)
<i>Research Data Management</i>	March 28, 2017	Renaine Julian	2 (1)
<i>Meeting Public Data Access Requirements</i>	April 11, 2017	Renaine Julian	2(1)
<i>Organizing and Sharing Your Personal Reference Library</i>	April 19, 2017	Kelly Grove and Julia Cater	10 (1)
<i>Research Metrics and Alt Metrics</i>	May 6, 2017	Devin Soper	2 (1)
<i>Library Research 101</i>	September 19, 2017	Kelly Grove and Jeff Philips	5 (0)
<i>Advanced Library Research</i>	September 28, 2017	Kelly Grove	2 (0)
<i>Collaborative Tools for Project Management</i>	October 12, 2017	Kelly Grove	3 (0)
<i>Understanding Research Data Management and Public Access Policies</i>	October 17, 2017	Kelly Grove and Devin Soper	5 (1)

**Note:** \*No sessions were held during the summer based on previous feedback that many people travel during the summer.

We also offer Postdoc Seminars where postdocs can present their research to their peers and solicit feedback. These are held by request for postdocs who wish to present. These seminars are often used as a practice session for conferences and job talks. No postdocs requested to schedule a seminar in 2017, however several postdocs have expressed interest in presenting in 2018 so this series will be revived in 2018.

## 4.4. Professional Development Resources at FSU, UF, and LANL

All MagLab postdocs have access to professional development opportunities at their affiliated institution. FSU, UF, and LANL each offer resources specifically for postdocs. FSU and UF host professional development seminars and new postdoc orientations, offer travel funding, and send out weekly newsletters to all

postdocs. LANL offers a matched mentoring program for postdocs as well as awards and prizes for outstanding performance in the postdoc program. Information on LANL's postdoc programs can be found here: <http://www.lanl.gov/careers/career-options/postdoctoral-research/postdoc-program/>, and information on UF's Office of Postdoctoral Affairs can be found here: <http://postdoc.aa.ufl.edu/>. Postdocs at all three sites are encouraged to take advantage of relevant resources at their affiliated institution to help expand their professional network and to leverage the resources that these institutions offer.

In Tallahassee, Kari works closely with FSU's [Office of Postdoctoral Affairs](#) and serves on the FSU Postdoc Taskforce. The FSU Office of Postdoctoral Affairs oversees the following: the coordination of professional development that aligns with the [National Postdoctoral](#)

# Chapter 4 – Education and Outreach

[Association's core competencies](#) for postdocs; the facilitation of networking and social events for FSU postdocs; hosting an annual postdoc symposium; and offering travel funding to support postdocs' professional travel. Additionally, postdocs at the Tallahassee site at the MagLab have access to FSU's Career Center, Office for Proposal Development, and Science Libraries. The Tallahassee site of the MagLab has developed a partnership with FSU's Science Libraries and Office of Proposal Development to host office hours at the Lab. Twice a month, a science librarian comes to the MagLab for drop-in appointments with postdocs and other lab staff to help them manage literature reviews, learn more about data management tools, storage, and plans. Additionally, the Office of Proposal Development hosts office hours once a month to provide postdocs and MagLab staff drop-in appointments to support them in applying for and submitting funding and fellowship applications.

## 4.5. Mentoring for MagLab Postdocs

The MagLab provides postdocs with the opportunity to be both a mentor and a mentee. Each site hosts undergraduate students and graduate students that are often mentored by MagLab postdocs. These experiences give postdocs an opportunity to improve and develop their mentoring skills. On the 2017 climate survey, several graduate students said that the mentoring they received from postdocs in their group was invaluable to their experience at the Lab.

As mentees, postdocs have access to their primary supervisor, PI, and other scientists at the Lab. MagLab postdocs are welcome and encouraged to develop relationships with the other staff scientists and users present in the Lab. On the annual survey to postdocs, we asked who they considered to be their primary mentor, and 86% said they met their mentor through working at the Lab, and 75% of postdocs said they felt they were being adequately mentored by their mentor.

In order to help those postdocs who do not feel they have a mentor at the Lab or feel they are not receiving enough mentoring from their supervisor, we have enacted a matched mentoring plan and mandatory postdoc annual evaluations. Four postdocs elected to participate in the pilot matched mentoring program in 2017. After one year with their matched mentors, postdocs will be given the option to continue with that mentor or be matched with another mentor to help expand their professional network. For annual evaluations, postdocs were able to customize the process for their annual evaluation to maximize the productivity of the meeting. 23% of postdocs used an Individual Development Plan (IDP) for their evaluation, 33% used the custom FSU postdoc evaluation form, 11% used the faculty evaluation procedure, and 33% created their own procedure with their supervisor. Kari was available to provide support in this process by request from postdocs or supervisors. She helped postdocs and supervisors understand the different options for the evaluation, choose the right procedure, and provided prompts to help postdocs and their supervisor set future goals.

## 4.6. Annual Survey to Postdocs

In 2017, the annual postdoc survey questions were part of the annual climate survey, which allowed us to compare postdocs' responses to the responses of other employees to provide better insight into the postdoc experience at the Lab. In 2017, postdoc responses overall aligned with other staff categories. 88.2% of postdocs reported having regular meetings with their supervisors, and 93.3% of postdocs said they were satisfied with the frequency of meetings with their supervisor. 100% of postdocs said that they were able to ask their supervisor questions about their job assignments. When asked to rate their supervisor on a scale of 1-5, postdocs overall gave their supervisors 4.18 for "encourages me in my career goals," 4.29 for "encourages me to ask questions," and 4.41 for "Listens to my ideas and inputs."



# Chapter 4 – Education and Outreach

**Table 7:** The demographics for our postdocs are below. These numbers were taken directly from the internal MagLab system on 11/20/17.

Race and Ethnicity- Excluding Affiliates

Race/Ethnicity	Number	Percentage (N= 30)
Hispanic or Latino/a	7	23.3%
Asian	14	46.7%
Black/African American	1	3.3%
American Indian or Alaska Native	0	0%
Native Hawaiian or Pacific Islander	0	0%
White/Caucasian	15	50%
Other	0	0%

**Table 8:** The Demographics for our Postdocs - Gender- Excluding Affiliates

Male	Female
21 (70%)	9 (30%)

**Table 9:** The Demographics for our Postdocs - Citizenship Status- Excluding Affiliates

US Citizen or Permanent Resident	Visa Holder
9 (30%)	21 (70%)

## 4.7. Future Plans

In 2018, Kari will be working to fine tune the matched mentoring program based on postdocs' experiences in the pilot program.

## 5. NHMFL SCIENTISTS' AND STAFFS' COMMITMENT TO OUTREACH

### 5.1. NHMFL Personnel Outreach

CIRL creates and maintains many opportunities for outreach to the local community, however many MagLab staff members conduct additional outreach outside of CIRL programs. CIRL provides support, guidance, and materials for any staff member who is

interested in doing outreach. As a result, people in the community see many different faces in MagLab outreach. In 2017, 97 MagLab staff members reported conducting outreach. Overall, 57% of these staff members conducted outreach outside of CIRL programs, however only 21% of long-term outreach (mentoring students for extended periods of time) was conducted outside of CIRL programs. Overall, MagLab staff reached 4,500 people in 2017 outside of the annual Open House and CIRL outreach conducted by CIRL staff. The primary audience for MagLab outreach was K-12 students (43%) and the general public (31%).

**Table 9:** Short-Term Outreach

Department	Tour of MagLab Facility		Presentation		Visit K-12 Classroom		Worked With K-12 Group at the Lab		Judged a Science Fair	
	Number of Scientists	Number of people reached	Number of Scientists	Number of people reached	Number of Scientists	Number of people reached	Number of Scientists	Number of people reached	Number of Scientists	Number of people reached
ICR	4	92	3	659	2	210	1	30	2	50
CMS			5	200						
ASC			1	375	1	50				
EMR	1	15	2	177						
NMR	2	52	1	40					1	16
UF	3	40								
LANL			8	625	7	205				
MS&T	3	80	1	105					1	50

# Chapter 4 – Education and Outreach

	Tour of MagLab Facility		Presentation		Visit K-12 Classroom		Worked With K-12 Group at the Lab		Judged a Science Fair	
DC	2	44	1	798					4	110
Geochem			1	60						
Director's Office	2	45	1	100						
<b>TOTAL</b>	<b>17</b>	<b>368</b>	<b>24</b>	<b>3039</b>	<b>10</b>	<b>465</b>	<b>1</b>	<b>30</b>	<b>8</b>	<b>226</b>

**Table 10: Outreach Audience: Short- and Long-Term Outreach**

Department	Number of People Reached						
	Number of Scientists	Elementary Students	Middle/High Students	Undergraduate and Graduate Students	Scientists and Faculty	General Public	K-12 Teachers
ASC	5	30	2	2	375	2	5
NMR	8	16	3	10	86		8
EMR	3		56	189			3
ICR	11	210	227	82	554		11
CMS	21	200	15	8	30	2	21
UF	7	36	30	3		10	7
DC	8	125	136		693		8
Geochem	5		3	5	60	2	5
MS&T	13	100	14	152	50	4	13
Director's Office*	12	230	545		75		12
LANL	5	30	2	2	375	2	5

Note: \*Includes Public Affairs, Safety, CIRL, and Microscopy

## 6. RESEARCH AND EVALUATION

### 6.1. Evaluation

Kari Roberts conducts all evaluation for our programs using the highest quality methodologies possible, as determined by experts in the field of education evaluation, including the NSF (The 2010 User-Friendly Handbook for Project Evaluation). Her expertise in eval-

uation and research statistics provides insight into the benefits of the MagLab's education programs and provides a data-driven direction for improvement for each program.

**Table 11: Conducted Evaluations**

Outreach	Form of Evaluation
Classroom Outreach	Post-survey to teachers after outreach conducted (formative assessment)
RET/REU/Internship	Pre-/post-survey measuring attitudes toward STEM careers, perceptions of STEM careers, and self-efficacy in STEM (for teachers in teaching STEM). Regular tracking of past participants to determine persistence over time
Summer Camps/Middle School Mentorship	Pre-/Post-survey measuring STEM Identity, STEM Self-Efficacy, perceptions of scientists and science careers. Regular tracking of past participants to determine how their interest in STEM evolves over time.
Graduate Student/Postdoc Professional Development	Annual survey to current postdocs to determine professional development needs and assess mentoring and annual tracking of graduate students and postdocs to determine career trajectories.
MagLab Users Summer School	Pre-/Post-survey assessing perceived value of program on their career trajectories.
Winter Theory School	Post-survey assessing participants perceived value of the Winter Theory School and how they will apply what they learned in the program.
Open House	Post-experience surveys and brief interviews given to attendees of the annual Open House to assess perceived benefits of the annual Open House and provide feedback for future years.

# Chapter 4 – Education and Outreach

## 6.2. Research

In 2017, Kari Roberts and Roxanne Hughes completed two research projects investigating the impacts of CIRL’s summer programs on participating students’ STEM identity growth. This resulted in two submitted publications in 2017:

- Roberts, K. & Hughes, R. (Submitted). The Role of STEM Self-Efficacy on STEM Identity for Middle School Girls After Participation in a Single-Sex Informal STEM Education Program, *Research in Science Education*.
- Hughes, R. & Roberts, K. (Submitted). STEM Identity Growth in Co-Educational and Single-Sex STEM Summer Camps, *International Journal of Gender, Science, and Technology*.

The following are a list of CIRL staff research publications in 2017:

### Peer-reviewed articles:

- Bremer, M. & Hughes, R. (2017). How Novices Perceive the Culture of Physics. *Journal of Women and Minorities in Science and Engineering*, 23(2), 171-194.
- Cox, B. E., Reason, R. D., Tobolowsky, B. F., Brower, R. L., Patterson, S., Luczyk, S., & Roberts, K. (2017). Lip Service or Actionable Insights? Linking Student Experiences to Institutional Assessment and Data-Driven Decision Making in Higher Education. *The Journal of Higher Education*, 1-28.

### Grants Awarded in 2017

In 2016, Roxanne and Kari were awarded a sub-award to conduct the research portion of an NSF-AISL grant, SciGirls CONNECT2: Investigating the Use of Gen-

der Equitable Teaching Strategies in a National STEM Education Network. For this grant, Roxanne and Kari are working with their graduate students, Jennifer Schellinger and Ely Chironos, to study the impact of SciGirls programming at 16 sites across the nation on participating youth’s STEM identity. Jennifer is also part of the team who is developing an updated literature review to improve the SciGirls Gender Equitable Teaching Strategies. Her work on this part of the project led to accepted submissions to the annual American Educational Research Association conference and the National Association of Research in Science Teaching conference. This research aligns with CIRL staff’s current STEM identity research and the results of this project can improve the overall impact of the MagLab programs as well.

### Grants Submitted in 2017

Roxanne partnered with faculty from Florida State University and Florida Agricultural and Mechanical University to submit a grant to the NSF ADVANCE program. This grant (Florida State University ADVANCE-Adaptation: Creating Empowerment through Recruitment, Networking, And Mentorship) would allow the PIs to develop trainings and utilize effective strategies in improving the recruitment, retention, and mentoring for women faculty in STEM disciplines at FSU.

## 6.3. Diversity and Inclusion in Education and Outreach

Diversity and inclusion is a large part of all of the MagLab’s educational and outreach activities. The following table highlights the demographics for our long term programs (e.g. one week or longer).

**Table 12: Education Programs in Diversity Classification**

2017	Total	% Women	% African American	% Hispanic	% American Indian/ Native American
<i>Research Experiences for Undergraduates (REU) summer</i>	18 undergraduates	44%	22%	22%	NA
<i>Research Experiences for Teachers (RET) summer</i>	10 K-12 teachers	80%	10%	20%	NA
<i>Middle School Mentorship (Fall)</i>	20 middle school students	55%	25%	20%	5%
<i>Internship</i>	35 (high school and college)	40%	14%	5%	NA
<i>Camp TESLA (Two 1-week camps)</i>	48 (middle school students)	48%	31%	12%	NA

# Chapter 4 – Education and Outreach

2017	Total	% Women	% African American	% Hispanic	% American Indian/ Native American
<i>SciGirls Summer Camp (Two 2-week camps)</i>	46 (middle school students)	100%	23%	8%	2%
<i>SciGirls Coding Camp (One 1-week camp)</i>	15 (middle school students)	100%	27%	27%	NA

## 6.4. Plans for 2018

As the new grant cycle begins, we are excited to maintain our programs and build on partnerships to continue to improve diversity within our programs. The MagLab will continue to strengthen partnerships with faculty and staff at the Florida Agricultural and Mechanical University with the goal of building a more diverse STEM workforce. We will continue to build our web-based outreach options to reach students and

members of the general public who do not have direct access to our facilities. We will continue to build on the strong educational and outreach partnership with UF and LANL MagLab facilities. We will continue to pursue professional development opportunities that maintain current knowledge of best practices in broader impacts as they apply to education, outreach, and diversity for K-16 students, teachers, faculty, and the general public.

# Chapter 4 – Education and Outreach

## Conferences & Workshops

Throughout the year, the National High Magnetic Field Laboratory hosts or sponsors a variety of workshops and conferences related to our science.

### Theory Winter School

January 8 to 12, 2018

Tallahassee, FL

The National High Magnetic Field Laboratory held its sixth Theory Winter School in Tallahassee, Florida from January 8 to 12, 2018. This year, 58 people attended the lectures provided by leading experts in quantum information theory, such as entanglement, and outstanding questions in many-body physics.

### 2nd International Symposium on Science and Technology of 2D Materials

February 3-4, 2017

Orlando, FL

2D materials beyond graphene are receiving enormous attention due to their potential in revolutionizing our understanding of fundamental sciences as well as our ability to push the limits of electronics for applications in nanodevices and smart materials. This 2nd International Symposium on Science and Technology of 2D materials aims to create an environment where leading experts in the field, young researchers and students involved in all aspects of 2D materials research can start a dialog, develop new knowledge and foster new ideas that will shape the future of 2D materials research. The workshop featured lectures by leading scientists in the field of 2D materials to present advances at the forefront of the field.

### RF Coil Workshop

April 3-7, 2017

Gainesville, FL

AMRIS hosted this workshop to train graduate and postdoctoral students in building RF Coils for magnetic resonance imaging and spectroscopy. Participants learned to build an RF quadrature coil, tune/match the coil and test performance, learn to use software to 3D print probe support parts, and learn to use software for 3D Electro-magnetic coil simulation. After the workshop, users should be able to build their own coils and test them in their individual facilities.

### Quantum Turbulence Workshop

April 10-12, 2017

Florida State University

This three-day international workshop brought senior researchers working in or having an interest in the field of quantum turbulence together with a group of junior participants (graduate students and postdocs) to discuss recent progress in QT and to exchange ideas on future research directions.

### 11th North American FT MS Conference

April 23-27, 2017

Key West, FL

This conference is the premier of its kind in the field of FT-MS and its applications. All talks are plenary (no parallel sessions) and range from instrumentation, to technique development in the biological/biomedical sciences ranging from pharmaceutical metabolism to proteomics, environmental analysis, and petroleomics, with special emphasis on new developments.

FT-ICR MS continues as a rapidly growing segment of the mass spectrometry market. With the increased placement of FT-MS instruments in Labs around the world and expanding applications of FT-MS in research, the FT-MS Conference is attracting a broader range of scientists who use a variety of consumables and instrumentation in their research.

### 2017 User Summer School

May 15-19, 2017

The 7th annual User Summer School introduced 22 students, early-career scientists, and potential users to the MagLab's infrastructure, experimental options, and support staff. Through a combination of tutorials, talks, and practical exercises, the User Summer School helped attendees develop skills for use in both their home Laboratory and across user facilities worldwide. This weeklong event features tutorials on measurement techniques, practical exercises and plenary talks from experts in the field of condensed matter physics.

### Gordon Research Conference on Superconductivity

June 3 - 4, 2017

Waterville Valley, NH

The conference focused on modern trends in superconductivity in correlated electron systems. The field of superconductivity has witnessed yet another rapid development in the last few years. There has been a strong revival of interest in superconductivity in the cu-

# Chapter 4 – Education and Outreach

brates, primarily due to new ideas about the interplay between superconductivity and competing orders and a plethora of new high-quality experimental results on photoemission, X-ray scattering, neutron scattering, resistivity and Hall conductivity, NMR, etc. There have been exciting new developments in the area of superconductivity in Fe-pnictides and Fe-selenides, including the observation of superconductivity with  $T_c$  above 100K in monolayers of FeSe and a set of new ideas about superconductivity in multi-orbital systems, the interplay between superconductivity and competing orders (e.g., nematicity), and the role of spin-orbit coupling. In parallel, superconductivity has been extensively studied in other monolayers, including graphene. There have been exciting new developments on superconductivity under external conditions, such as light-induced superconductivity and superconductivity under pressure. Another area of rapid progress, both experimental and theoretical, is topological superconductivity. Besides, there have been substantial advances in the last 1-2 years in the search of new superconducting materials with tailored properties.

## Users Committee Meeting and Workshop 2017

October 19 – 21, 2017

Gainesville, FL

The workshop preceding the 2017 MagLab Users Committee Meeting focused on recently developed technologies for probing quantum materials and biological systems in high magnetic fields. Presentations highlighted advanced optical spectroscopy techniques to characterize quantum states of materials and dynamic nuclear polarization to enhance measurements of biomolecular species.

## Advanced EPR School: Theory and Applications

October 26-27, 2017

Tallahassee, FL

The EMR program at the MagLab presented the Advanced EPR School: Theory and Applications. This two-day, hands-on Electron Paramagnetic Resonance (EPR) course was directed at graduate students and postdocs. The course covered the theories of continuous wave and pulsed EPR, as well as advanced EPR techniques and applications in chemical, biological, and materials sciences. Participants had an opportunity to learn and practice various EPR techniques on the state-of-the-art EPR spectrometers at the MagLab. The EPR school took

place jointly with the SEMRC conference and attracted 26 people.

## 2017 Southeastern Magnetic Resonance Conference

October 27 – 29, 2017

SEMRC has a long history of bringing together leading scientists to discuss the latest developments in NMR, EPR, and MRI. This year, 130 people attended to exchange ideas and recent magnetic resonance research highlights, including new applications and technique development. The SEMRC puts a special emphasis on the participation of young scientists (students and post-docs) and provides excellent opportunities to exchange new exciting results with their peers as well as with the leaders in the field.

## Novel Unconventional Superconductivity

August 7-19, 2017

Institut d'Etudes Scientifiques (IESC) in Cargese, Corsica  
For nearly four decades the studies of unconventional superconductors have been largely following the blueprint set by superfluid  $^3\text{He}$ . Recent studies of Fe-based superconductors, topological superconductivity, artificial superconducting heterostructures, and new developments in the cuprate physics have introduced a number of new concepts to the field. These ideas effectively define a new era where the field is moving definitively beyond the  $^3\text{He}$  paradigm for the first time. However, while concepts developed for one materials class are often relevant to others, they have not yet filtered into the discussion across the materials boundaries, let alone propagated to other subfields. This workshop informed junior scientists about these new concepts in a coherent and unified framework, and explicitly showed how they are realized in a variety of new compounds, as well how they enhance and provide a new viewpoint for the studies of more traditional unconventional superconductors.

Topics

- Multiband/multiorbital phenomena
- Topological superconductivity; influence of spin-orbit coupling
- Superconductivity in noncentrosymmetric systems
- Strong interactions and BCS-BEC crossover
- Artificial superconducting structures: monolayers, superlattices, bulk surfaces
- Coexistence & competition of superconductivity with other phases

# Chapter 4 – Education and Outreach

- Novel aspects of disorder

## Weekly Seminar Series:

In addition to these special workshops and conferences hosted or sponsored by the MagLab, weekly seminars were held in departments across the Lab:

1/17: Seminar By Jose Rodriguez, California State University Los Angeles - *High-Tc Superconductivity in Iron Superconductors at the Strong-Correlation Limit*

1/18: Seminar By Leonid Rokhinson, Purdue University - *Experimental search for non-Abelian excitations*

1/20: Seminar By Xi Dai, Chinese Academy of Science - *Weyl semimetals, Chiral anomaly and Chiral magnetic effect in solid materials*

1/27: Seminar By Seungyong Hahn, National High Magnetic Field Laboratory - *No-insulation (NI) REBCO coils*

2/1: Seminar By Parans Paranthaman, Oak Ridge National Laboratory - *Additive Manufacturing of High Performance NdFeB Permanent Magnets*

2/2: Seminar By Parans Paranthaman, Oak Ridge National Laboratory - *Novel tire-derived carbon electrodes for lithium and sodium ion batteries*

2/3: Seminar By Andrey Chubukov, University of Minnesota - *Superconductivity near a quantum critical point*

2/10: Seminar By Gang Cao, University of Colorado - *Spin-Orbit-Tuned Ground States in Iridates*

2/17: Seminar By Joseph Maciejko, University of Alberta - *Superconducting Dirac fermions and mirror symmetry*

2/24: Seminar By Tomoya Asaba, University of Michigan - *Rotational Symmetry Breaking in a Trigonal Superconductor Nb-doped Bi<sub>2</sub>Se<sub>3</sub>*

3/3: Seminar By Masa Ishigami, UCF Orlando - *Ultra-low friction of gold nanocrystals on graphene*

3/6: Seminar By Wayne Kimura, STI Optronics - *Fiber-optic Magnetic Field Diagnostic for HTSC Magnets*

3/9: Seminar By Ibrahim Kesgin, Argonne National Laboratory - *From development of high performance superconducting 2G-HTS conductors to fabrication of a prototype HTS undulator*

3/10: Seminar By Ernesto Bosque, Applied Superconductivity Center, MagLab - *Bi<sub>2</sub>Sr<sub>2</sub>CaCu<sub>2</sub>O<sub>8+δ</sub> Round Wire (Bi-2212 RW) Technology for High Field NMR Magnets*

3/24: Seminar By Yasuo Yoshida, University of Tokyo - *Atomic-scale visualization of surface-assisted orbital order in the heavy fermion compound CeCoIn<sub>5</sub>*

4/7: Seminar By Marcelo Rozenberg, Orsay, Univ. de Paris - *Neuromorphic electronic behavior in transition metal oxides system*

5/5: Magnets and Materials Seminar By Paul Xinbo and Andy Gavrilin - *Post mortem studies of a 32 T REBCO prototype coil after 3 final quenches*

5/15: Seminar By Kenjiro Hashi, High-field NMR Group, National Institute for Materials Science (NIMS) - *1020 MHz NMR Magnet Achievement*

6/19: Seminar By Jun Lu, MS&T - *Experience of testing large quantity of Nb<sub>3</sub>Sn superconducting wires for ITER*

7/14: Seminar By Shirin Mozaffari, University of Austin, TX - *Effects of Oxygen Content on the Transport Properties of the PrAlO<sub>3</sub>/SrTiO<sub>3</sub> Interface*

7/19: Seminar By So Noguchi, Hokkaido Univ., Japan - *Electromagnetic Simulation on No-Insulation REBCO Magnets*

8/22: Seminar By Robert Walsh, MS&T - *Analysis of 4 K Fatigue Data for Three Austenitic Steels*

9/8: Seminar By Yi Li, Johns Hopkins University - *Mono-pole Harmonic Superconductivity in Doped Weyl Semimetals*

9/26: Seminar By Jack Toth, MS&T - *Design, Construction and First Testing of a 41.5 T All Resistive Magnet at the MagLab in Tallahassee*

10/6: Seminar By Pouyan Ghaemi, City Collage of New York - *Light induced fractional Hall phases in Graphene*

10/13: Seminar By Debanjan Chowdhury, Massachusetts Institute of Technology - *Mixed-valence insulators with neutral Fermi-surfaces*

10/23: Seminar By Seongshik Oh, Rutgers, Physics and Astronomy - *Rise of Topological Quantum Materials on Defect Engineering*

11/1: Seminar By Yoshinori Haga, Advanced Science Research Center, JAEA - *Single crystal growth, magnetism and superconductivity in actinide intermetallic compounds*

11/6: Seminar By Shreyas Balachandran, MS&T - *Mechanical and Axial Fatigue Behavior of 18 percent Nickel Maraging Steel C250 for Cryogenic Applications*

11/28: Seminar By Alexander Otto, President, Solid Material Solutions - *Strong wires, cables and coils based on the BSCCO superconductor*

# Chapter 4 – Education and Outreach

## Broadening Outreach

*In addition to the Diversity and Education sections which speak to the MagLab's work in broadening outreach through education and underrepresented groups, the Lab's staff are regularly presenting new research and sharing information about our user program at national and international conferences, workshops, and seminars. Each presentation, poster, or abstract opportunity offers the chance for scientists around the world to learn more about the Lab's research capabilities and broaden our user program to appeal to new scientists from varying levels – from graduate students and postdocs to seasoned scientists.*

In 2017, Public Affairs, the User Program Chief of Staff, and the user facility directors worked together on a new user booklet to help promote the facility to new potential users. "Elevate" features an overview of each of the Lab's seven user facilities coupled with general infor-

mation about applying for magnet time, funding options, and educational programs. To showcase each user facility, a series of covers were designed featuring a unique instrument within each facility.



NATIONAL HIGH  
**MAGNETIC**  
FIELD LABORATORY

**NationalMagLab.org**

FLORIDA STATE UNIVERSITY  
UNIVERSITY OF FLORIDA  
LOS ALAMOS NATIONAL LABORATORY



NATIONAL HIGH  
**MAGNETIC**  
FIELD LABORATORY

**NationalMagLab.org**

FLORIDA STATE UNIVERSITY  
UNIVERSITY OF FLORIDA  
LOS ALAMOS NATIONAL LABORATORY





# Chapter 4 – Education and Outreach

*In 2017, MagLab staff gave about 275 lectures, talks and presentations across 14 foreign countries and over a dozen states. Here are some featured talks from across departments and around the globe;*

Facilities	Conference Site	Location
NMR Facility	10th Alpine Conference on Solid State NMR	Chamonix, France
ICR Facility	11th North American Fourier Transform Mass Spectrometry Conference	Key West, FL, USA
DC Field Facility, NMR Facility, MS & T	13th European Conference on Applied Superconductivity	Geneva, Switzerland
AMRIS Facility at UF	15th Asian Symposium on Medicinal Plants, Spices, and other Natural Products (ASOMPS)	Asia
NMR Facility, MS & T, AMRIS Facility at UF	2017 25th Annual Meeting of the International Society of Magnetic Resonance in Medicine	Honolulu, HI, USA
DC Field Facility, CMT/E	2017 Annual Joint Symposium - Florida Chapter of the American Vacuum Society - UCF	Orlando, FL, USA
DC Field Facility, CMT/E	2017 QCM Young Investigators meeting, Oak Ridge National Laboratory	TN, USA
NMR Facility	2017 Sino-American International Research Conference	NHMFL, Tallahassee, FL, USA
ICR Facility	231st Electrochemical Society Meeting	New Orleans, LA, USA
ICR Facility	253rd ACS National Meeting & Exposition	San Francisco, CA, USA
ICR Facility	254th ACS National Meeting & Exposition	Washington, D.C., USA
Applied Superconductivity Center, MS & T	25th International Conference on Magnet Technology	Amsterdam, Netherlands
Pulsed Field Facility at LANL	2D Materials Workshop, Ohio State University	OH, USA
EMR Facility	46th Southeastern Magnetic Resonance Conference (SEMRC)	NHMFL, Tallahassee, FL, USA
ICR Facility	4th Annual Southeastern Biogeochemistry Symposium	Athens, GA, USA
NMR Facility	58th Experimental Nuclear Magnetic Resonance Conference, Asilomar Conference Grounds	Pacific Grove, CA, USA
NMR Facility, ICR Facility	61st Annual Biophysical Society Meeting	New Orleans, LA, USA
CMT/E	62nd Annual Conference on Magnetism and Magnetic Materials	PA, USA
ICR Facility	65th American Society for Mass Spectrometry Conference on Mass Spectrometry & Allied Topics	Indianapolis, IN, USA
ICR Facility, AMRIS Facility at UF	69th Southeastern Regional Meeting of the American Chemical Society (SERMACS)	Charlotte, NC, USA
ICR Facility	73rd Southwest Regional Meeting of the American Chemical Society	Lubbock, TX, USA
ICR Facility	9th Annual Mass Spectrometry Applications in Clinical Sciences Conference	Palm Springs, CA, USA
ICR Facility	9th US Symposium on Harmful Algae	Baltimore, MD, USA
EMR Facility	Advanced EPR School: Theory and Applications	NHMFL, Tallahassee, FL, USA
DC Field Facility	AIRAPT, 26th International Conference on High Pressure Science & Technology	Beijing, China
ICR Facility	American Geophysical Union Fall Meeting	New Orleans, LA, USA
DC Field Facility	APCTP Quantum Materials Symposium	Yong-Pyong, South Korea

# Chapter 4 – Education and Outreach

Facilities	Conference Site	Location
EMR Facility	APS Bridge Program and Graduate Education Conference	College Park, MD, USA
ICR Facility, Geochemistry Facility	ASLO Joint Aquatic Meeting	Honolulu, HI, USA
ICR Facility	Association of Regional University Pathologists Conference	Salt Lake City, UT, USA
ICR Facility	AVS 64th International Symposium & Exhibition	Tampa, FL, USA
NMR Facility	Berlin Ultra High Field Facility 7th Annual Symposium	Berlin, Germany
AMRIS Facility at UF	Biomedical Engineering Society Annual Meeting	Phoenix, AZ, USA
Applied Superconductivity Center	CEC-ICMC 2017, Cryogenic Engineering Conference and International Cryogenic Materials Conference	Madison, WI, USA
ICR Facility	Chemical Oceanography Gordon Research Conference	New London, NH, USA
AMRIS Facility at UF	Chiari & Syringomyelia Foundation Hydrodynamics Symposium	Athens, GA, USA
ICR Facility	Chinese Academy of Science Institute of Biophysics	Beijing, China
DC Field Facility	Condensed Matter Physics Seminar, University of Cambridge	Cambridge, UK
CMT/E	Condensed Matter Seminar, University of Michigan	Ann Arbor, MI, USA
Pulsed Field Facility at LANL	Conference on Strongly Correlated Electron Systems	Prague, Czech Republic
NMR Facility	Conference on Viruses and Cells	Heidelberg, Germany
CMT/E	Contributed talk at the workshop "Open space between aperiodic order and strong electronic correlations"	Annecy, France
EMR Facility	Department of Chemistry, Wroclaw University	Wroclaw, Poland
DC Field Facility	Department of Physics, Jackson State University	Jackson, MS, USA
DC Field Facility, CMT/E	DoE PI's meeting (Condensed Matter Experimental Program)	Gaithersburg, MD, USA
DC Field Facility, NMR Facility	ENC 2017 - 58th Experimental Nuclear Magnetic Resonance Conference	Pacific Grove, CA, USA
AMRIS Facility at UF	Energy Frontier Research Center Meeting	Athens, GA, USA
Applied Superconductivity Center	EUCAS 2017 - European Conference on Applied Superconductivity 2017	Geneva, Switzerland
EMR Facility	Euromar	Warsaw, Poland
Applied Superconductivity Center	FCC Week 2017	Berlin, Germany
Applied Superconductivity Center	FESAC TEC	PPPL, Princeton, NJ, USA
NMR Facility	Frontiers of NMR in Life Sciences	Keystone, CO, USA
ICR Facility	Fullerenes in Space Workshop, University of Edinburgh	UK
Pulsed Field Facility at LANL	Fundamental Optical Processes in Semiconductors - 2017	Skamania Lodge, WA, USA
DC Field Facility	Fundamentals of Quantum Materials Winter School 2017	MD, USA
Applied Superconductivity	GARD-SRF Roadmap Workshop	Fermilab, Batavia, IL, USA

# Chapter 4 – Education and Outreach

Facilities	Conference Site	Location
Center		
DC Field Facility	German Physical Society spring meeting	Berlin, Germany
Geochemistry Facility	Goldsmith Conference	Paris, France
NMR Facility	Gordon Research Conference - Muscle: Excitation-Contraction Coupling	Les Diablerets, Switzerland
CMT/E	Gordon Research Conference on Superconductivity	Waterville Valley, NH, USA
Pulsed Field Facility at LANL	GRAPHENE-2017	Barcelona, Spain
AMRIS Facility at UF	Greater Everglades Ecosystem Restoration (GEER) 2017	Coral Springs, FL, USA
ICR Facility	HUPO 2017	Dublin, Ireland
Applied Superconductivity Center	IEEE Technology Milestone Symposium for the Tevatron	Fermilab, Batavia, IL, USA
Pulsed Field Facility at LANL	INSA- Toulouse, University of Toulouse	Toulouse, France
NMR Facility	International Conference of Structural Biology – Key-note Lecture	Zurich, Switzerland
CMT/E	International School and Symposium on Nanoscale Transport and Photonics	Atsugi Kanagawa, Japan
NMR Facility, MS & T	International Society for Magnetic Resonance ISMAR 2017	Quebec City, Canada
DC Field Facility, Pulsed Field Facility at LANL	International Workshop: Topological Matter Meets Quantum Information - Shanghai Jiao Tong University	Shanghai, China
CMT/E, DC Field Facility	Invited talk at the "Superstripes 2017" International Conference	Ischia, Italy
CMT/E	Invited talk at the 12th International Symposium on Crystalline Organic Metals, Superconductors and Magnets (ISCOM2017)	Zao, Miyagi, Japan
DC Field Facility, CMT/E	Invited talk at the International School and Workshop on Electronic Crystals (ECRYS-2017)	Cargese, France
CMT/E	Invited talk at the Spring 2017 Meeting of the German Physical Society	Dresden, Germany
DC Field Facility, CMT/E	Invited talk at the workshop "Quantum criticality in metallic system's," Aspen Center for Physics	Aspen, CO, USA
DC Field Facility, Education (NHMFL only)	Invited talk, Department of Physics	Virginia Tech, VA, USA
CMT/E	Invited tutorial lecture at the "Workshop on Localisation in Quantum Systems" at King's College	London, UK
CMT/E	Invited tutorial talk at the 14th Material Science for Young Scientists "New Frontier of Molecular Materials," Tohoku Univ.	Sendai, Japan
DC Field Facility, CMT/E	Iowa State University/AMES Labs	Iowa, IA, USA
Applied Superconductivity Center	Jefferson Lab- Accelerator Seminar Series	Newport News, VA, USA
CMT/E	Johns Hopkins University Physics Department Seminar	Baltimore, MD, USA
DC Field Facility	JPS 2017 Autumn Meeting	Japan
CMT/E	Kavli Institute for Theoretical Physics	San Francisco, CA, USA
DC Field Facility, CMT/E	Leiden University	Netherlands

# Chapter 4 – Education and Outreach

Facilities	Conference Site	Location
ICR Facility	Life Detection Technologies: For Mars, Enceladus & Beyond	Tokyo, Japan
MS & T	Low Temperature Superconductor Workshop	Santa Fe, NM, USA
High B/T Facility at UF, UF Physics, DC Field Facility, Pulsed Field Facility at LANL	March Meeting American Physical Society	New Orleans, LA, USA
Pulsed Field Facility at LANL	MIT Valleytronics Workshop	MIT, MI, USA
EMR Facility	National Postdoctoral Association annual meeting	San Francisco, CA, USA
ICR Facility	Natural Resources and Environmental Management Seminar Series invited speaker, University of Hawaii	Manoa, Hawaii, USA
ICR Facility	Petrophase 18th International Conference on Petroleum Phase Behavior and Fouling	Le Havre, France
CMT/E	Physics Colloquium at the Institute for Physics	Belgrade, Serbia
CMT/E	Physics Colloquium at the Royal Holloway University of London	London, UK
CMT/E	Physics Colloquium at the T. D. Lee Institute	Shanghai, China
CMT/E	Physics Colloquium at the University of Virginia	Charlottesville, VA, USA
CMT/E	Physics Seminar at the Department of Physics, Fudan University	Shanghai, China
CMT/E	Physics Seminar at the Department of Physics, Nanjing University	Nanjing, China
CMT/E	Physics Seminar at the Physikalisches Institut, University Stuttgart	Stuttgart, Germany
ICR Facility	Planetary Science Vision 2050 Workshop	Washington, D.C., USA
EMR Facility	Poster, National High Magnetic Lab summer internship presentations	NHMFL Tallahassee, FL, USA
CMT/E	Poster, conference on Quantum Dynamics: From Models to Materials	Aspen, CO, USA
MS & T	Quantum Turbulence International Workshop	NHMFL Tallahassee, FL, USA
NMR Facility	Rocky Mountain Conference on EPR	Quebec City, Canada
NMR Facility	Rosomoff Research Day	Miami, FL, USA
MS & T	Seminar talk at Osaka City University	Osaka, Japan
MS & T	Seminar talk at University of Florida Department of Physics	Gainesville, FL, USA
CMT/E	Simon Fraser University	Vancouver, Canada
ICR Facility	Society for Freshwater Science	Raleigh, North Carolina, USA
Applied Superconductivity Center	SRF 2017	Lanzhou, China
DC Field Facility	Symposium G05, Oxide Memristors, the 232nd Electrochemical Society Meeting	National Harbor, MD, USA
NMR Facility	The 93rd Florida Annual Meeting and Exposition	Tampa, FL, USA
Applied Superconductivity Center	The Cryogenic Engineering Conference and the International Cryogenic Materials Conference (CEC-ICMC)	The Monona Terrace Community and Convention Center, Madison, WI, USA
DC Field Facility	The Seventy-Second Calorimetry Conference (CALCON 2017)	Colorado Springs, CO, USA

# Chapter 4 – Education and Outreach

Facilities	Conference Site	Location
MS & T	The Workshop of Introducing Talents on Electromagnetic Metallurgy & Materials Science with High Magnetic Fields	Shenyang, China
EMR Facility	Thomas University	Thomasville, GA, USA
Applied Superconductivity Center	TTC Topical Workshop - RF Superconductivity: Pushing Cavity Performance Limits	Fermilab, Batavia, IL, USA
Pulsed Field Facility at LANL	UCSD Physics	La Jolla, CA, USA
CMT/E	University of British Columbia, Physics Colloquium	Vancouver, Canada
CMT/E	University of Maryland, College Park	College Park, MD, USA
MS & T	US Cosmic Visions: New Ideas in Dark Matter	MD, USA
ICR Facility	US HUPO	San Diego, CA, USA
ICR Facility	US-China Cooperation Meeting	Qinghai Lake, Xining, China
Pulsed Field Facility at LANL	WINDS conference	Kohala, HI, USA
DC Field Facility, CMT/E	Workshop on Quantum Materials: Electronic Correlations, Spin-Orbit Coupling, and Topology, Oak Ridge National Lab	TN, USA
DC Field Facility, CMT/E	Workshop on Topological Phases and Functionality of Correlated Electron Systems Institute for Solid State Physics - University of Tokyo	Tokyo, Japan
DC Field Facility	XIII Russian Conference on Physics of Semiconductors	Ekaterinburg, Russia
Applied Superconductivity Center	XXIV IUCr Congress	Hyderabad, India
DC Field Facility	Zhejiang Workshop on Correlated Matter	Hangzhou, China



## Chapter 5 – In-house Research

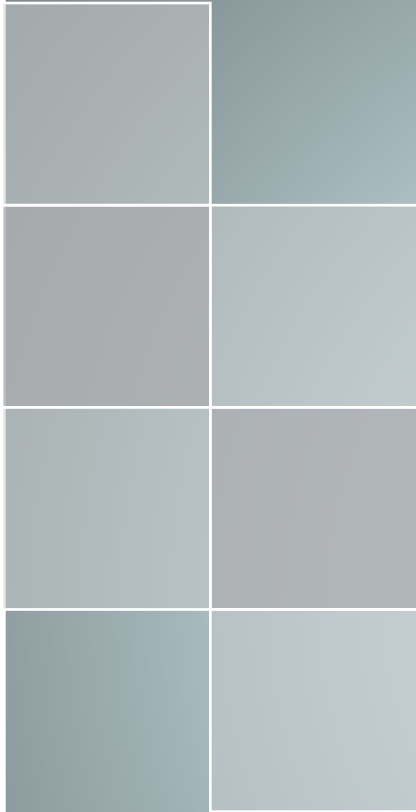

# Chapter 5 – In-house Research

## 5.1. Magnets and Magnet Materials

A central feature of the MagLab's mission is the provision of unique, high-performance magnet systems that exploit the latest materials and magnet design developments for our users. As we move forward, maintaining a balance of development of new magnet systems with new technology is of critical importance to keep us at the forefront. Collaborations with other leading industrial, academic, and government groups that develop these new magnet technologies is built into many of these thrusts.

### Executive Summary

During 2017, three record user magnets at the MagLab reached specification! In March, the *Series-Connected Hybrid magnet (SCH)* reached its uniformity and stability specifications of 1 ppm/1 cm DSV (**Figure 1**). During the ensuing commissioning phase, the magnet has been operated regularly testing probes, instrumentation, and operating procedures. Journal articles are starting to emerge. The magnet went into routine operation in January 2018.

largest resistive magnet labs worldwide. The platform for it has been completed and the insert cryostat should arrive in the 2<sup>nd</sup> quarter of 2018. User service will start shortly thereafter.

In December, the 32 T all-superconducting magnet reached field. This magnet is now being moved to the millikelvin facility, where it is expected to serve the user community. This magnet is the culmination of an extended development program that included SuperPower who produced the REBCO conductor and Oxford Instruments who developed the outer Nb<sub>3</sub>Sn and Nb-Ti coils. It is also a major stepping-stone in a much larger story: the emergence of superconducting magnets at revolutionary higher fields due to the application of High Temperature Superconducting (HTS) materials. HTS cuprate materials were discovered in 1986 but strong degradation of superconductivity at grain boundaries made conductor development arduous. Fabrication methods developing high crystallographic texture slowly appeared, allowing small coils of the Bi-Sr-Ca-Cu-O conductors to be tested inside large bore superconducting and resistive magnets. However, these early BSCCO HTS conductors had too low a conductor current density to be suitable for application of ultra-high field (UHF) magnets. In 2007, several hundred meters of REBCO coated conductors with almost perfect biaxial texture were produced by SuperPower Inc. They enabled a 7 T pancake coil to be tested in a background field of 20 T for a total of 27 T. This test demonstrated an HTS conductor that was sufficiently strong, stable, and robust enough that useful high field magnets could finally be imagined.

A suite of UHF test coils followed (**Figure 2**) with the MagLab reaching 34 T in 2008 and 45 T in 2017. The first REBCO coils were sufficient to allow a proposal to NSF to construct an all-superconducting 32 T user magnet. This just completed 32 T magnet is the first HTS magnet to operate at significantly higher fields than the

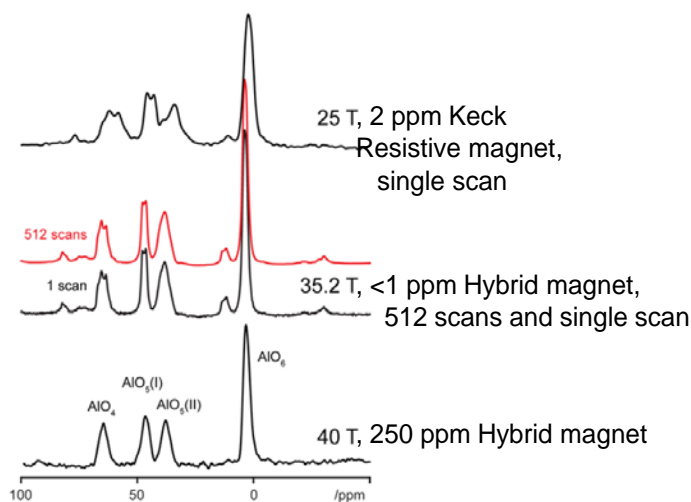

**Figure 1:** NMR spectra in SCH magnet. Data from the SCH magnet operating at 35.2 T (1.5 GHz) has high resolution that is maintained over 512 scans demonstrating a unique combination of field intensity, uniformity, and stability.

In August, a new resistive magnet reached 41.5 T, eclipsing the previous mark of 38.5 T set by the lab in Hefei, China. The magnet is significantly larger than other MagLab resistive magnets (coil outer diameter = 1 m vs. 0.6 m), but similar in size to those in Hefei, Nijmegen, and Grenoble. It uses the Florida-Bitter magnet technology, which is now used at 6 of the 7

# Chapter 5 – In-house Research

## Magnet and Materials

23.4 T maximum of any LTS magnet. 32 T operates at modest stress with a quench protection system that has been thoroughly tested and should allow reliable operation for years to come. Although REBCO conductor technology has made many advances in the last decade, it is still an expensive and complex manufacturing challenge that has not yet found the widespread electric utility market that inspired its development. Magnet use for ultra-high fields is a new market that is helping expand the capabilities of REBCO coated conductors, not least because of the great potential of No Insulation (NI) REBCO magnets. In 2017, inside the 31 T 50 mm bore resistive magnet, we tested the third of a small insert magnet series (Little Big Coil) that had started with insulated technology at 34 T in 2008 but which, in NI form, has now allowed 40, 42.5 and, in August 2017, 45.5 T at the phenomenal conductor current density of  $1400 \text{ A/mm}^2$  (Figure 2).

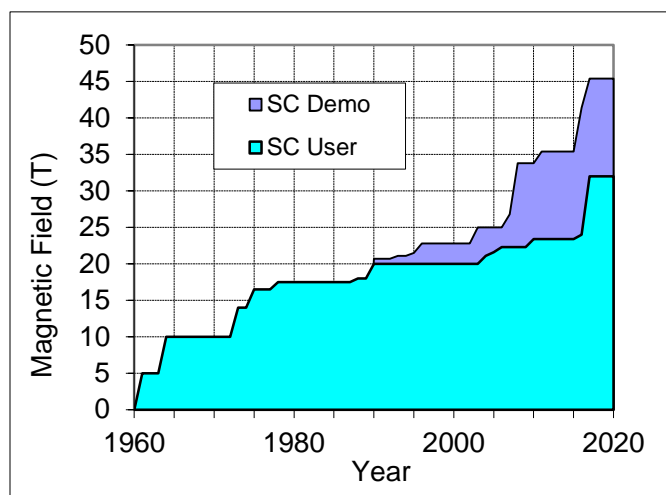

**Figure 2:** Field attained in superconducting user magnets (lower) and HTS test coils (upper) vs. time. The 32 T provides fields in a user magnet that rivals the best test coils of a few years ago. However, the latest test-coil results indicate 32 T is just the beginning.

However, REBCO is not the only HTS magnet technology being developed at the MagLab. Bi-2212 is also of great interest, being round, multifilament, twisted, and macroscopically isotropic; all the same favorable characteristics possessed by  $\text{Nb}_3\text{Sn}$  and Nb-Ti. The challenge of Bi-2212 is that it must be reacted after winding like  $\text{Nb}_3\text{Sn}$ , but with the added complexity that the peak temperature is  $890^\circ\text{C}$  rather than  $700^\circ\text{C}$ . To

## Magnet and Materials

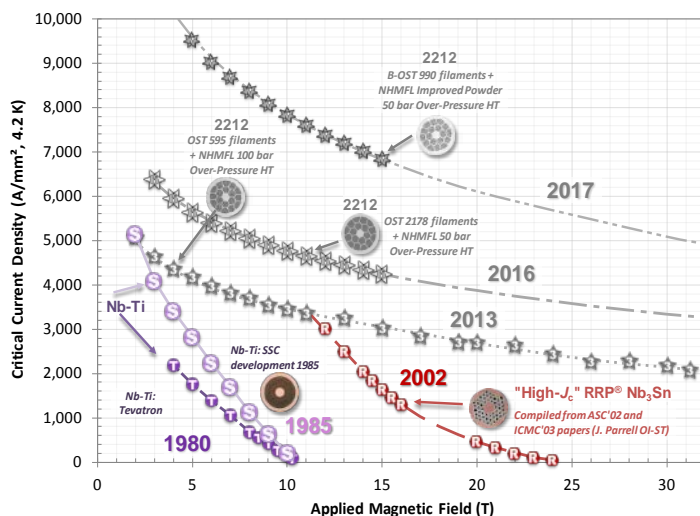

**Figure 3:** Progress in round wire Bi-2212 conductor development was very strong in 2017 due to close collaborations between the MagLab, the wire producer B-OST, two small company Bi-2212 powder producers, and LBNL. Bi-2212 offers a very high conductivity normal metal matrix without need for diffusion barrier and low hysteretic losses, making it suitable for high field homogeneity magnets. All the elements needed for making it a magnet technology now exist at the MagLab.

extract the best properties (Figure 3), the heat treatment must occur at 50 bar (1 bar  $\text{O}_2$ , balance Ar). This capability was installed at the MagLab about 3 years ago. Many test magnets have been made for our own purposes and for external users like LBNL and Oxford Instruments Nanoscience. Extensive external support for this technology comes from the DOE-Office of High Energy Physics. The technology development has benefited from great support too from wire producer Bruker-Oxford Superconducting Technology and two small companies, nGimat and MetaMateria, who make the Bi-2212 powder. The huge advances made in this conductor technology in the last 4 years are shown in Figure 3. The end-use goal at the MagLab is for application to ultra-high field NMR (1.3-1.6 GHz), as envisaged in MagSci. Test coils aiming at about 1 GHz using both 2212 and Bi-2223 are planned for early 2018.

In addition, progress has been made in development of high-strength Cu-Nb, Cu-Ag, and Cu-Ag-Fe alloys suitable for pulsed and dc resistive magnets. In



# Chapter 5 – In-house Research

## Magnet and Materials

particular, higher strength was attained in Cu-Ag alloys cast in a magnetic field due to refinement of the microstructure.

In short the MagLab is actively pursuing HTS magnet technologies based on all 3 available HTS conductors. The coming years should see a proliferation of UHF magnets for condensed-matter physics, NMR, fusion, accelerators, axion detection, neutron, and x-ray scattering and the other ambitious MagSci challenges of 2013.

### HTS Magnets and Materials 32 T Magnet Project

The 32 T superconducting magnet reached its design magnetic field and met all specifications during its first test in liquid helium. A peak field of 32.1 T was confirmed using  $^{63}\text{Cu}$  NMR measurements. Ramping at the nominal rate of 32 tesla per hour, both +32 T and -32 T were achieved repeatedly. Helium use is modest with an average use of 6 liters/hour for 4 hours of ramping at full rate plus 1 hour at 32 T for example. The clear bore is 34 mm and is at 4.2 K, as is the magnet. A 15 tesla 250-mm bore Low Temperature Superconductor (LTS) magnet, built by Oxford instruments, serves as the outer magnet. A pair of REBCO High Temperature Superconductor (HTS) insert coils, designed and built at the NHMFL, are separately powered but mechanically integrated with the LTS magnet and thereby result in this 32 tesla system.

This magnet is the first superconducting user magnet to exceed the range of what is possible with low temperature superconductors (23.4 T to date by Bruker). The strongest superconducting user magnet combining HTS and LTS is a cryo-cooled magnet at Tohoku University in Japan that demonstrated 24.6 tesla and has been operated since 2017 as a user magnet at 24 tesla. It contains one sizeable HTS coil, but does not significantly exceed the magnetic field strengths possible with LTS conductors and is larger than the 32 T magnet. In a broader historical view, superconducting user magnets advanced typically in occasional small increments, taking 42 years from 1975 to advance 7.5 tesla and reach 24 tesla. The 8 tesla increment achieved with the 32 T magnet not only delivers on the promise of high temperature superconductors to enable magnets far beyond the limits of Nb-based low temperature superconductors, it does so with the

## Magnet and Materials

largest increment of peak field in the history of superconductivity. Technical activities in 2017 include a redesign of the switchgear for the battery bank, that powers the HTS quench protection heaters [1,2], providing a greater level of redundancy and short-circuit tolerance. The final number of batteries was selected after testing the quench protection equipment on a dummy resistor. After cooling to 4.2 K, first the magnet was energized. The quench detection parameters, which were set to protect the magnet in case of a full-field quench, were found to be too sensitive at low magnetic fields. Low field flux jumps can cause significant but transient coil voltages and thereby false trips of the quench detection, although the effect of flux jumps on the central magnetic field was found to be small. As quench dynamics are mild at low field, the quench detection sensitivity at lower fields could be reduced without undue risk to the magnet. Deliberate manual triggers of the quench protection were performed at 16, 22.5, and 28 tesla to verify system behavior and generate data to benchmark the quench simulation code against. The simulations were proven adequate, generating confidence in the prediction that the magnet system would safely remain within design parameters in case of a spontaneous full-field quench at 32 T. Spontaneous quenches however did not occur at any point in testing and operating the 32 T magnet.

Magnetic field quality was first studied with a Hall-effect probe and later with a  $^{63}\text{Cu}$  NMR probe that could be moved along the axis of the magnet. Peak field was observed to be 32.10 tesla. Based on the data presented in **Figure 5**, a uniformity of 125 ppm in a 1 cm diameter spherical volume is deduced, which compares favorably with the 500 ppm target set at the beginning of this project. Noticeable screening currents are present in the HTS conductor, but the maximum hysteresis between actual and nominal magnetic field during a sweep from zero to 32 to -32 and back to zero tesla was 0.7% at low field, significantly smaller than some predictions in the literature [3] and extrapolation from data on smaller REBCO coated conductor coils had suggested. The deviation from nominal is less than 0.1 T at full field. Drift of the magnetic field after reaching a set point at full rate is modest at 10 ppm/minute and can be reduced by more than an order of magnitude to the power supply drift level with a slight overshoot. Thus the magnetic field quality is

# Chapter 5 – In-house Research

## Magnet and Materials

better than expected and significantly better than initially specified.

Currently the 32 T magnet system is in transition from testing to permanent installation in the Millikelvin facility at the NHMFL with user operations anticipated by the summer of 2018.

### References

- [1]Markiewicz, W.D., et al., IEEE Trans. Appl. Supercond., **22**, 4300707 (2012)
- [2]Weijers, H.W., et al., IEEE Transactions on Applied Superconductivity, **26-4** 4300807 (2016)
- [3]Yanagisawa, Y. et al. "Effect of YBCO-coil shape on the screening current induced magnetic field intensity," IEEE Transactions on Applied Superconductivity, **20**, 744-747, 2010.



**Figure 4:** A Picture of Cell 4 with the 32 T magnet under test. 1: Cryostat; 2: Quench valves; 3 & 4: LTS and HTS magnet power supply respectively; 5: Battery banks to power quench protection heaters; 6: Rack with permanent electronics to monitor and safeguard the magnet. The hardware and screens in the front are for testing only and handle diagnostics.

## No-insulation REBCO coil-development

### 1. Introduction

The no-insulation (NI) winding technique has been demonstrated to provide a practical and easy solution for the protection of high temperature superconductor (HTS) magnets because of its “self-protecting” feature. In order to make the NI technique play a more important role in HTS applications, we performed the following experiments on both small-scale test coils and multi-coil magnets.

## Magnet and Materials

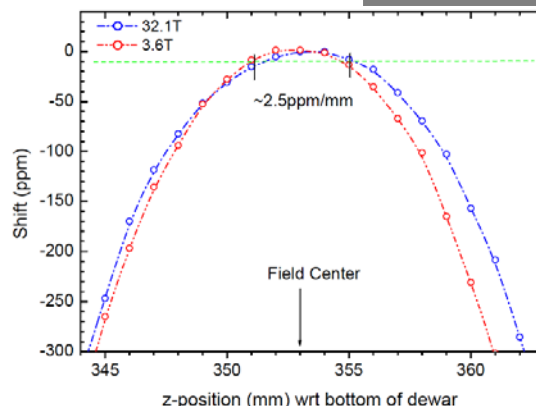
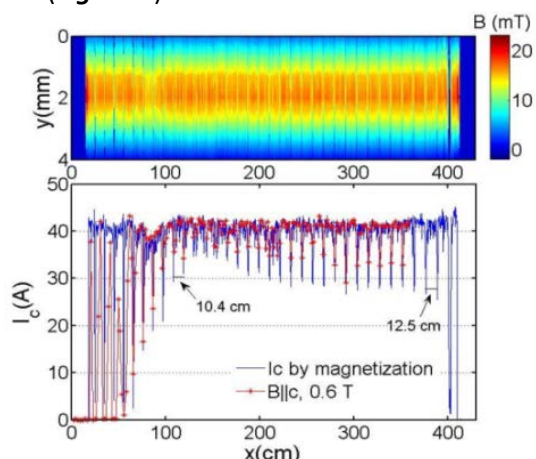

**Figure 5:**  $^{63}\text{Cu}$  NMR map of the magnetic field on axis at low and high magnetic field, confirming the magnitude and position of peak field, and indicating a uniformity of 125 ppm in a 1 cm diameter spherical volume.

### 2. Small-scale test coil research

#### Post-quench behavior of metallic cladding coils:

During a long-term quench recovery test of the metallic cladding (MC) coil, a background low temperature superconductor (LTS) magnet was quenched at 30 s after the MC test coil’s quench. According to the lengthwise  $I_c$  test using the YateStar ( $B_c$  of 0.6 T), an in-house continuous  $I_c$  measurement system at the Applied Superconductivity Center (ASC), a periodic damage pattern was observed: 10.4 cm of the peak-to-peak distance in the inner pancake section and 12.5 cm in outer, which agree well with the perimeter of each section (**Figure 6**).



**Figure 6:** YateStar measurement results of the damaged MC tape after the LTS background magnet quenched.

# Chapter 5 – In-house Research

## Magnet and Materials

The results imply that the damage was “localized” and propagated in the radial direction.

**Quench analysis of a 3 double pancake NI coil:** A test coil comprised of 3 NI double pancake (DP) coil was constructed, and tested in a cryostat with liquid helium at 4.2 K. The 3DP test coil was quenched at the power supply current of 243 A which corresponds to 4.72 T of center field. The propagation behavior for the typical quench of multi-stacked NI coil was estimated, and the data obtained from simulation agreed reasonably well with experimental data of coil voltages and magnetic field (**Figure 7**).

**Defect-irrelevant winding technique:** Multiple NI coils were wound containing multiple defects varying in “severity.” Severity is defined to be the ratio of defect critical current and lengthwise average critical current. At 77 K “defective” coils seem to have a critical current matching 90-97% of that of a healthy coil (**Figure 8**). The difference between the voltages is the inductance due to each multi-defect (MD) coil having different amount of turns.

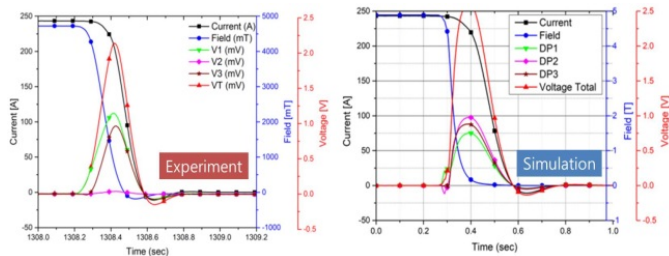

**Figure 7:** Experiment and simulation results of the 3DP test coil during the moment of quench.

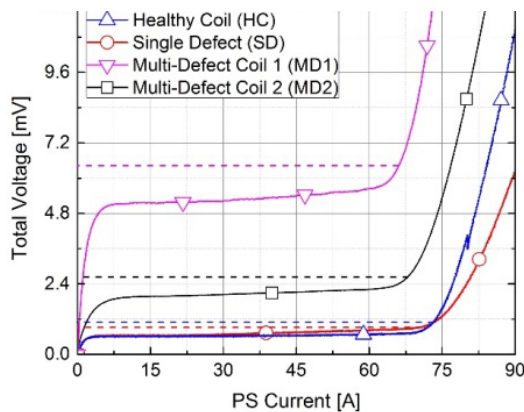

**Figure 8:** Multi-defect coils compared with healthy coil counterpart.

## Magnet and Materials

### 3. Multi-coil magnet research



**Figure 9:** A picture of all-REBCO NI insert, which consists of a stack of 12 single pancake coils.

**Test of an NI REBCO insert coil:** An all-REBCO NI insert (**Figure 9**) was constructed and tested with a resistive background magnet at Cell 7 (DC Field Facility). The results showed that the insert generated 14.4 T in the 31.1 T background field, i.e., a total combined field of 45.5 T. At the maximum field, the average coil current density was 1262 A/mm<sup>2</sup>, while the REBCO tape current density was 1419 A/mm<sup>2</sup> (**Figure 10**).

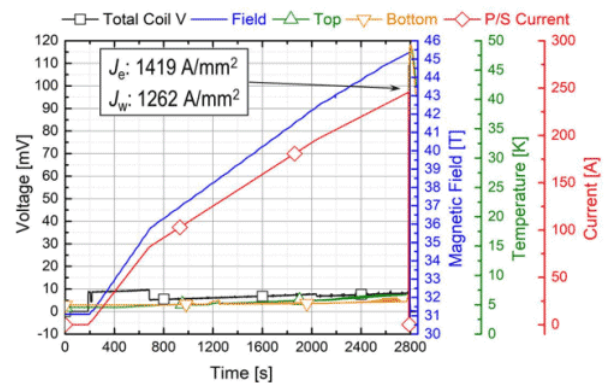

**Figure 10:** Overall profiles measured during the insert coil operation with 31 T background magnet.

After the insert quenched at 45.5 T, it was visually confirmed that no burn-out was observed. However, YateStar measurement results showed that most of the pancake coils were degraded except for pancakes 2 and 11, which are located near the top and bottom, respectively (**Figure 11**).

**13 T NI insert magnet:** The 13 T NI insert magnet was installed in a cold bore of a 7 T low temperature super-conductor background magnet to complete the 20 T all-superconducting system. The insert consists of a stack of 24 double pancake coils wound with multi-width (MW) REBCO tapes manufactured by the SuNAM, Co., Ltd. **Figure 12** shows the operational result for the 13 T NI insert with the 7 T LTS outsert. The LTS outsert was quenched when the

# Chapter 5 – In-house Research

## Magnet and Materials

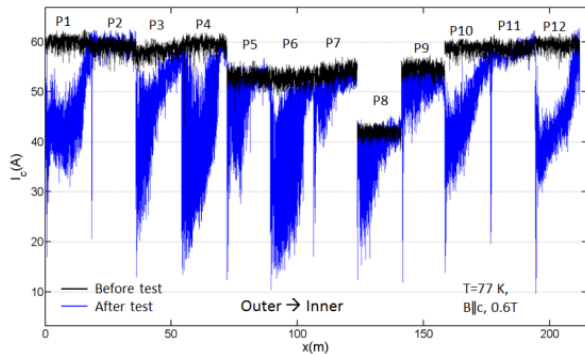

**Figure 11:** Lengthwise  $I_c$  measurement results of the REBCO insert coil.

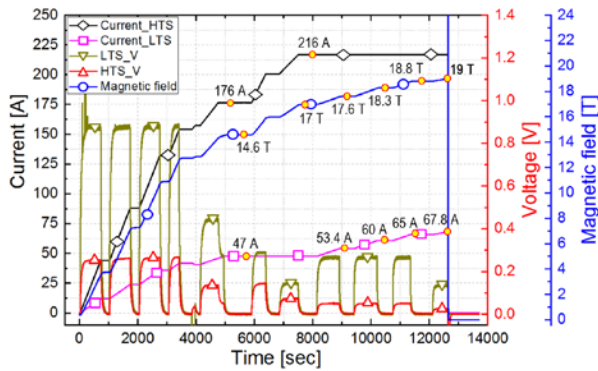

**Figure 12:** Shows the operational result for the 13 T NI insert with the 7 T LTS outsert. The LTS outsert was quenched when the combined center field reached 19 T, which eventually led to the NI HTS insert quench.

combined center field reached 19 T, which eventually led to the NI HTS insert quench.

**Bi-2212 Coil Development:** There are two major pushes for the application of Bi-2212 round wire in the next generation of high field magnet systems: Accelerator magnets for the HEP community, like advanced dipoles made with Rutherford cables, and solenoids for NMR. The development of high field HTS dipole magnets in the US is centered at the LBNL with whom we collaborate on the coil heat treatment issues. One focus at the NHMFL is the development of high magnetic field nuclear magnetic resonance (NMR) magnets beyond 30 T (1 GHz) using HTS (High Temperature Superconductors). We are in the process of building a layer-wound, round-wire, Bi-2212 insert

## Magnet and Materials

magnet (“Platypus-2”), which in combination with our 16.5 T low temperature superconducting (LTS) outsert magnet is expected to approach 1 GHz. The NHMFL’s purchase of a high pressure furnace in which Bi-2212 coils can now be processed to achieve excellent and reproducible transport properties, has enabled systematic R&D work on Bi-2212 wire for superconducting high field magnet applications.

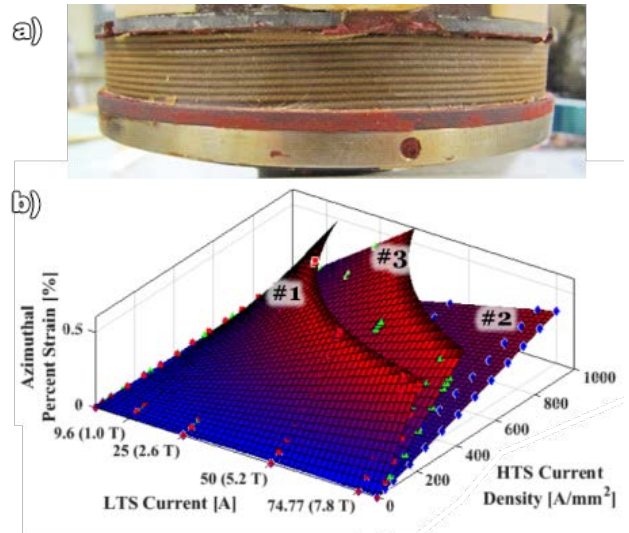

**Figure 13:** Test coil “Riky-3” and predicted coil performance envelope of three Riky-type test coils with various amount of reinforcement.

Mechanically Bi-2212 wire can be most usefully compared with  $Nb_3Sn$  wire and to understand how this wire should be used in high field magnets we made a series of test-coils and models particularly focusing on the challenge of mechanical reinforcement. At LBNL, dipole magnets using Bi-2212 Rutherford cable were made and tested. These magnets were over pressure heat treated (OPHT) at the NHMFL. After changing our conductor insulation approach, all of the recently made Bi-2212 solenoids were without electrical shorts between windings after the OPHT. In in-field tests of up to 8 T, the coils showed small hysteresis ( $\pm 1$  mT to  $\pm 5$  mT) and the coils rapidly responded to change of the operation current. Without any reinforcement, the coil shown in **Figure 13** would have experienced a maximum hoop stress of about 300 MPa. Performance envelopes created by FEA models, predicted 348 A for the onset of damage and an actual trip was observed at 350 A, which revealed a good match between models and

# Chapter 5 – In-house Research

## Magnet and Materials

experiments. It also shows that the implemented coil reinforcement strategies worked. Below the onset of thermal runaway, the coils could be load-cycled many times without any signs of coil degradation. A Platypus-2 model coil with several turns of Bi-2212 wire and thermal mass equivalents distributed at critical locations was made and OPHT'ed. Transport data from wire samples indicate proper tuning of the furnace, which is required for the actual Platypus-2 heat treatment, **Figure 14**. LBNL's racetrack coils that we OPHTed in our furnace

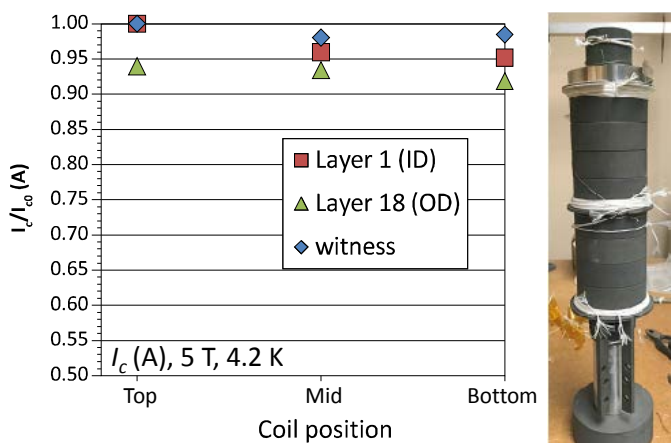

**Figure 14:** Sample  $I_c$  and Platypus-2 model coil with several turns of Bi-2212 wire and thermal mass equivalents (stack of Inconel rings).

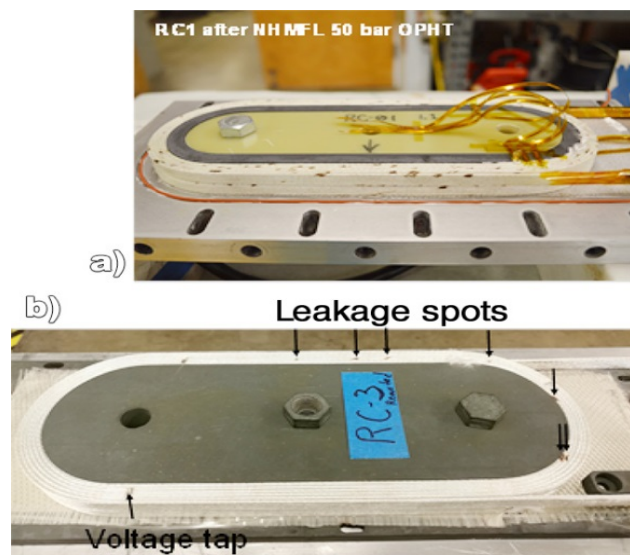

**Figure 15:** Alumino-silicate braided racetrack coils RC-1 (a) and RC-3 (b). A clear difference can be seen in the amount of leakage between RC-1 without and RC-3 with the  $TiO_2$  coating.

## Magnet and Materials

showed  $I_c$  of 8.2 kA in tests at LBNL. This is a fourfold increase over LBNL's racetrack coils heat-treated at 1 bar and a significant step forward in advanced dipole technology. For the first time LBNL used our  $TiO_2$  coating on their Rutherford cables and a significant reduction of conductor leakage was observed, **Figure 15**.

**Table 1:** Specifications of thin-wall stress test coils, Riky 1, 2, and 3.

Coil #	Riky 1	Riky 2	Riky 3
Wire dia. [mm]	Bare 1.3 Ins. 1.56	Bare 1.3 Ins. 1.56	Bare 1.0 Ins. 1.3
Insulation	TiO <sub>2</sub> coat + mullite braid		
ID ; OD [mm]	124.8 ; 136.0	122.8 ; 134.0	122.8 ; 132.2
Height [mm]	14.8	16.4	13.0
Turns	34	39	38
Inductance [mH]	0.29	0.33	0.34
Conductor [m]	14.7	16.1	16.2
Impregnation	VPI (NHMFL 61)		
Reinforcement	none	co-winding + reinforcement	co-winding

**Mechanical Reinforcement for Bi-2212 Wire:** We are pursuing a coil technology that can manage high magnetic stress by adding reinforcements into winding packs. After the decommissioning of the 168 mm large bore resistive magnet we selected an alternative test bed, a 140 mm and 8.5 T cryo-cooled LTS magnet to advance our reinforcement techniques with newly-designed Bi-2212 stress test coils, dubbed "Riky." We made three different Riky coils that contained varying amounts of reinforcement. As shown in **Table 1**, coil size and number of turns of each Riky were kept similar to generate similar magnetic stress on the coil pack. The first coil, Riky 1, had no reinforcement as a base reference. Riky 2, on the other hand, had a full suite of reinforcement, expecting that it would not reach its critical stress level. Riky 3 was in between Riky

# Chapter 5 – In-house Research

## Magnet and Materials

1 and 2 in terms of reinforcement, to refine our FEM modeling and confirm our approach. All three coils were impregnated with epoxy using vacuum pressure impregnation. To observe their critical stress limits, we monitored the voltage response of the coils while they were being charged (background field of 8 T at 4.2 K). **Figure 16** shows the voltage responses of the Riky coils. The magnetic stress on the coil increases as its charging current goes up. When the stress is close to a critical level of the coil, its voltage will start to rise as a consequence of the superconducting to normal transition of the Bi-2212 conductor. As shown in **Figure 13**, Riky 3 could withstand a higher magnetic stress than the other Riky coils before it reached to  $1 \mu\text{V}/\text{cm}$  criterion. Later we found that Riky 3's was not limited by stress at all, but rather by heating introduced through the external current leads. Riky 3 performance was, as expected, between Riky 1 and 2. We also performed low cycle fatigue tests and observed no evidence of fatigue. This indicated that the Bi-2212 strands in the Riky coils were still operating below their critical strain limit, demonstrating the efficiency of our stress management techniques. Concurrent FEM modeling efforts are ongoing to refine the modeling parameters for the Bi-2212 winding packs in wire-by-wire resolution.

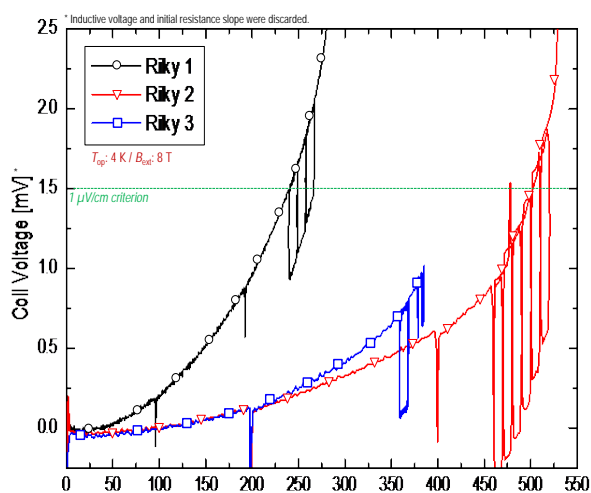

**Figure 16:** Voltage responses of Riky coils with different level of reinforcements

**High-pressure furnace operation:** When operating our high-pressure furnace, the goal is to run an over-pressure heat treatment (OPHT) according to a schedule optimized for wire performance. Reviewing

## Magnet and Materials



**Figure 17:** a) 'CERN/Twente' OPHT and b) 'LBNL RC3' OPHT. The yellow stars highlight positions of short witness samples.

the performance of recent OPHT'd coils alongside the recorded temperature profiles during the OPHT's, a significant amount of information was extracted and key parameters of the OPHT's identified. Perhaps the most significant conclusion comes from the dependence of coils' current density carrying potential ( $J_c$ ) and their time in the melt ( $t_{melt}$ ), defined as the time elapsed between which Bi-2212 has been observed to begin melting (during heating) and re-solidifying (during cooling),  $883^\circ\text{C}$  and  $874^\circ\text{C}$ , respectively. The rates of heating and cooling between temperature set points were kept constant, and a high priority was placed on approaching the freezing temperature of the Bi-2212 when cooling down after reaching the maximum OPHT schedule temperature ( $T_{max}$ ). Just above  $874^\circ\text{C}$ , the cooling rate is set to change from  $0.25^\circ\text{C}/\text{min}$  to a slower rate of  $0.042^\circ\text{C}/\text{min}$ . Hence, changing rates above  $874^\circ\text{C}$  significantly adds time ( $24 \text{ min}/^\circ\text{C}$ ), to  $t_{melt}$ . On the other hand, any elevation in  $T_{max}$  results in a marginal additional time of  $5.5 \text{ min}/^\circ\text{C}$  ( $1.5 \text{ min}/^\circ\text{C}$  during heating and  $4 \text{ min}/^\circ\text{C}$  during cooling) to  $t_{melt}$ . Ideally,  $t_{melt}$  should be  $86.5 \text{ min} - 10.5 \text{ min}$  from melting onset ( $883^\circ\text{C}$ ) to a  $T_{max}$  of  $890^\circ\text{C}$ ,  $12 \text{ min}$  at  $T_{max}$ , and  $64 \text{ min}$  from  $T_{max}$  down to the onset of re-solidification

# Chapter 5 – In-house Research

(874 °C). However, the observed consequences for not reducing the cooling rate before the onset of re-solidification is a rapid reduction in wire critical current ( $J_e$ ), and thus it is common to conservatively add a few °C to the 874 °C set point. Here, adding 2 °C to the set point adds 48 min to  $t_{melt}$ , which is more than 50% of the ideal time. Shown below are two OPHT's, with a variety of different  $t_{melt}$  values at different heights within the furnace. **Figure 17** shows height locations of witness samples inside the furnace, and **Figure 18** illustrates the  $J_e$  performance of each of the short samples depicted. These two results are characteristic of all OPHT's performed in the Deltech furnace to date.

**Bi2223 Coil Development:** A program of fabrication and testing of layer-wound coils made with Sumitomo Type HT-NX conductor is underway. Test coils were designed to investigate the practical limits of stress and strain on the conductor, in conditions similar to those expected in a 30 T NMR magnet. Two coils have been fabricated so far [1].

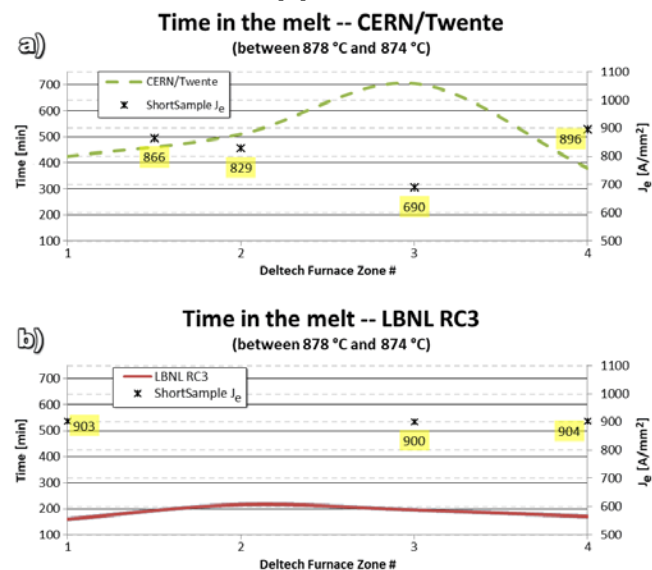

**Figure 18:** Dependence of  $J_e$  on  $t_{melt}$  for the 'CERN/Twente' (a) and 'LBNL RC3' OPHT's (b). X-axes reflect the height location of each short sample inside the furnace.

The first coil, named 'Short-Thick 1', shown in **Figure 19**, is designed to assess the performance of the conductor under conditions of high winding and hoop strain. The second coil, named 'Tall-Thin 1', shown in



**Figure 19:** Test coil 'Short-Thick 1' and fixture

**Figure 20**, is designed for high axial strain. Both coil designs are constrained to use a single 300 meter piece length of conductor, with no splice joints. The first coil was tested at 4.2 K in a background field of 14 T. The coil was ramped to 450 A, and then cycled 20 times from 225-450 A. The coil generated 5.7 T to make a total field of 19.7 T. **Figure 21** graphs the components of strain at the midplane and ends of the coil vs. winding radius at the peak field and current. The peak strain on the conductor was an unprecedented 0.82% on the innermost turns at the ends of the coil. The conductor current density was 299 A/mm<sup>2</sup>. The coil survived the test without degradation. [2]

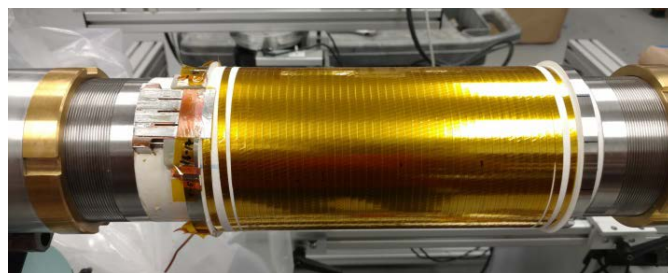

**Figure 20:** Test coil 'Tall-Thin 1' on winding machine

The second coil 'Tall-Thin 1' has been fabricated and is now being readied for testing. This coil is expected to make 2 Tesla in a 14 Tesla background field at its strain limit. A demonstration NMR measurement will be performed during the test.

Findings from the successful test of 'Short-Thick 1' suggest that Sumitomo Type HT-NX conductor is a feasible option for HTS insert coils for 30 T NMR magnets.

## References

[1]W.S. Marshall et al., "Bi-2223 Test Coils for High Resolution NMR Magnets", IEEE Trans. On Appl. Supercond., Volume: 27, Issue: 4, June 2017

# Chapter 5 – In-house Research

[2]W.S. Marshall et al., “Fabrication and Testing of a Bi-2223 Insert Coil for High Field NMR Magnets”, IEEE Trans. On Appl. Supercond., MT-25 Special Issue, 2018

## Iron-based superconductors (FBS)

### 1. Vortex pinning studies

Several flux pinning studies for Fe-based superconductors (FBS) were conducted to investigate their potential for applications [5.FBS.1] as well as their fundamental properties [5.FBS.2. 5.FBS.3, 5.FBS.4, 5.FBS.5].

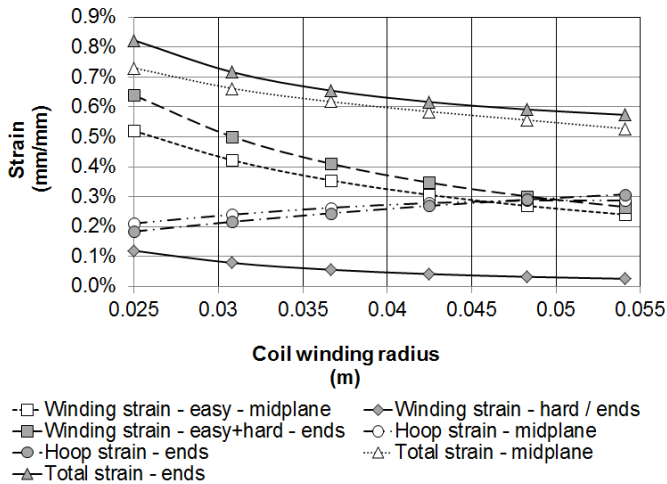

**Figure 21:** Strain in coil windings, Bi-2223 test coil ‘Short-Thick 1’, 14 T background, 450 A

**Figure 22** represents the main results of our  $\alpha$ -particle irradiation experiment on an NdFeAs(O, F) thin film [5.FBS.5]. In general, the irradiation suppressed the critical temperature,  $T_c$ . However, the impact of the irradiation on the upper critical field,  $H_{c2}$ , are dependent on the field orientation respect to the direction of irradiation which was normal to the film surface (i.e. the  $c$ -axis of NdFeAs(O, F)). The  $H_{c2}$  slope monotonically increased with increasing disorder caused by the irradiation when  $H$  is parallel to the  $c$ -axis, whereas, with  $H//ab$ -plane, the slope remains initially constant until the disorder became high at high irradiation doses. This behaviour suggests that NdFeAs(O, F) needs a different level of disorder density to get into the dirty limit along the  $c$ -axis and the  $ab$ -plane direction.

Even with the high density of disorder that caused the modest  $T_c$  suppression, we observed that an improvement of critical current density,  $J_c$ , and pinning

force in  $H//c$  ( $J_c(H//c)$ ,  $F_p(H//c)$ , respectively) is limited only at the low temperature regime. The  $J_c$  and  $F_p$  were reduced at high temperature. We also analysed  $F_p(H//c)$  to determine the dominant pinning mechanisms and any changes due to irradiation. There are two types of mechanism to be considered here;

- Interface or “surface” contributions (S): These are determined by planar defects normal to the  $c$ -axis;
- Point defect contributions (PD): These are determined by intrinsic point defects that were already present in the as-grown sample, and by vacancies and interstitials artificially introduced by irradiation.

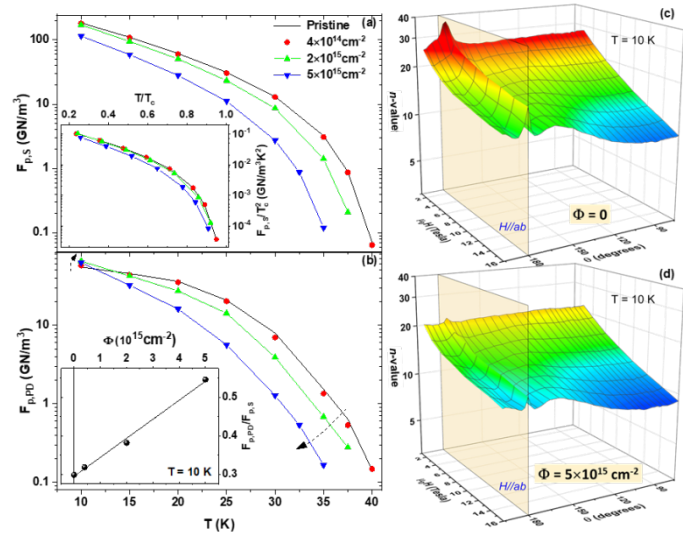

**Figure 22:** (a)-(b) Analysis of the pinning force density in a NdFeAs(O,F) thin film before and after irradiation with  $\alpha$ -particles: (a) interface (or “surface”) contribution  $F_{p,S}$ , (b) point defect contribution  $F_{p,PD}$ . The inset of (a) shows  $F_{p,S}$  normalized to  $T_c^2$ ; the inset of (b) shows that  $F_{p,PD}/F_{p,S}$  is proportional to the fluence (c)-(d)  $n$ -value (as determined by the  $I$ - $V$  characteristics) as a function of magnetic field and angle with the  $ab$ -planes for the same film before (c)

The S and PD contributions to  $F_p$  ( $F_{p,S}$ ,  $F_{p,PD}$ , respectively) are plotted as a function of  $T$  in **Figure 22**. At low irradiation doses, the  $F_{p,S}$  simply rescales with  $T_c^2$  (due to the variation of the condensation energy) whereas at higher irradiation levels it is more strongly suppressed, indicating that the density of states was



# Chapter 5 – In-house Research

reduced by the irradiation damage. On the other hand, the  $F_{p,PD}$  is suppressed over a wide range of temperatures as a result of the  $T_c$  suppression caused by the irradiation, but, at low temperature where the effect of  $T_c$  suppression is marginal,  $F_{p,PD}$  increases as the irradiation dose increases. This suggests that  $F_{p,PD}$  is determined by the density of point defects which is proportional to the irradiation dose.

We also studied the I-V characteristics ( $V \propto I^n$ ) to gain an insight into the vortex pinning strength through the exponent  $n$  (proportional to the pinning potential). We found that NdFeAs(O,F) exhibits an unusual trend of the  $n$ -value when plotted as a function of angle between the magnetic field and its  $ab$ -plane. In the pristine sample, the angular dependence of  $n$ -value is derived by the intrinsic pinning mechanisms due to its layered crystal structure. At the point where the magnetic field approaches close enough to the  $ab$ -planes, only short segments of vortices get trapped by the  $ab$ -planes or film surface, causing temporary suppression of the  $n$ -value. Then, at an angle closer to the  $ab$ -plane, the vortices are fully locked-in between the film layers, generating a strong sharp peak in the  $n(\theta)$  curves (**Figure 22c**). However, after irradiation, those features almost disappear, indicating that the irradiation-induced point defects decrease the pinning efficiency along the  $ab$ -planes (**Figure 22d**).

## 2. A cleaner synthesis route for FBS

In 2017, we started to re-evaluate our synthesis procedure for FBS BaFe<sub>2</sub>As<sub>2</sub> (Ba122) polycrystals. In order to develop this material towards conductor forms, it is very important to establish a methodology that can attain high intergrain  $J_c$  in polycrystalline bulks. Indeed we have found that even very high quality Ba122 polycrystalline samples at present still have large extrinsic current blockage at the grain boundaries (GBs) caused by oxygen segregation and strong variations from stoichiometric. In particular, oxygen segregation can cause serious  $J_c$  degradation because it disrupts the local nanostructure and because oxygen-containing

impurities (O<sub>2</sub>, H<sub>2</sub>O, CO<sub>2</sub>) can form oxides, hydroxides, and/or carbonates with the Ba122 elements, all of which are current-blocking insulators. In order to investigate the possible oxygen sources that contaminate Ba122, we purchased and extensively tuned a new glove box. This new glove box is equipped with an O<sub>2</sub> and H<sub>2</sub>O purifier system that enables us to reduce the O<sub>2</sub> and H<sub>2</sub>O levels below 0.01 and 0.3 ppm respectively, better than even the best standard glove box. We have started utilizing this new glove box and now are moving to look into the effects of the cleaner sample processing to investigate other possible sources of oxygen contamination.

## References

- [5.FBS.1] K. Iida, H. Sato, C. Tarantini, J. Hänisch, J. Jaroszynski, H. Hiramatsu, B. Holzapfel, H. Hosono, *High-field transport properties of a P-doped BaFe<sub>2</sub>As<sub>2</sub> film on technical substrate*, Scientific Reports 7, 39951 (2017).
- [5.FBS.2] S. Richter, F. Kurth, K. Iida, K. Pervakov, A. Pukenas, C. Tarantini, J. Jaroszynski, J. Hänisch, V. Grinenko, W. Skrotzki, K. Nielsch, R. Hühne, *Superconducting properties of Ba(Fe<sub>1-x</sub>Ni<sub>x</sub>)<sub>2</sub>As<sub>2</sub> thin films in high magnetic fields*, Appl. Phys. Lett. 110, 022601 (2017).
- [5.FBS.3] V. Grinenko, K. Iida, F. Kurth, D.V. Efremov, S.-L. Drechsler, I. Cherniavskii, I. Morozov, J. Hänisch, T. Förster, C. Tarantini, J. Jaroszynski, B. Maiorov, M. Jaime, A. Yamamoto, I. Nakamura, R. Fujimoto, T. Hatano, H. Ikuta, R. Hühne, *Selective mass enhancement close to the quantum critical point in BaFe<sub>2</sub>(As<sub>1-x</sub>P<sub>x</sub>)<sub>2</sub>*, Scientific Reports 7, 4589 (2017).
- [5.FBS.4] J. Lee, J. Jiang, F. Kametani, M.J. Oh, J. Weiss, Y. Collantes, S. Seo, S. Yoon, C. Tarantini, Y.J. Jo, E. Hellstrom, S. Lee, *High critical current density over 1 MA·cm<sup>-2</sup> at 13 T in BaZrO<sub>3</sub> incorporated Ba(Fe,Co)<sub>2</sub>As<sub>2</sub> thin film*, Supercond. Sci. Technol. 30, 085006 (2017).
- [5.FBS.5] C. Tarantini, K. Iida, N. Sumiya, M. Chihara, T. Hatano, H. Ikuta, R. K. Singh, N. Newman and D. C. Larbalestier, *Effect of  $\alpha$ -particle irradiation on a NdFeAs(O,F) thin film*, Supercond. Sci. Technol. 31, 034002 (2018). *Invited paper for the Special Issue on Irradiation Effects in Superconductors*

# Chapter 5 – In-house Research

## Resistive Magnets and Materials

### DC Magnets

**41.4 T:** A new resistive magnet has been installed at the NHMFL which has set a world record of 41.5 T in a 32 mm bore [Figure 23]. The NHMFL held the record for this class of magnets from 1994 - 2014 and the research done in those years established the NHMFL as the premier high field lab worldwide. We expect that this upgraded magnet, with 3 T higher field than any other resistive magnet, and 6.5 T higher than the older NHMFL magnets, will facilitate the NHMFL's continuing leadership in high-field science.

For 25 years, the NHMFL used magnet housings designed for 20 MW of power and that allowed for coils of 610 mm outer diameter. The new magnet has an outer diameter of 1000 mm, the same as three competing labs. The magnet employs the Florida-Bitter technology developed at the MagLab and now used in 6 of the 7 largest labs worldwide. It also uses advanced current-density grading accomplished via a novel stacking technique that facilitates optimal power and stress distribution.

For 17 years, the NHMFL has been the only lab worldwide providing DC field >40 T to the scientific community. This new magnet doubles the number of magnets available in this range and is also able to sweep field continuously from -41.5 T to +41.5 T (within 8 minutes).

**SCH Insert:** 2017 has been a very successful first full year of operation of the SCH. The resistive insert represents a brand new design including four new resistive coils of which most operate close to the mechanical strength limits of its winding materials. The completion of one year of heavy operation (over 725 hours of running time) without the requirement of a single coil maintenance action reflects an exceptional track record.

**Maintenance:** In 2014, the MagLab finished the construction and commissioning of a novel resistive insert for the Series-Connected Hybrid (SCH) magnet operated at the Helmholtz Zentrum Berlin (HZB) in Germany. This magnet design includes a *unique bore with 30 degree opening angle at world record 25 T central field (US patent no. 7,825,760)*. The effective

conical bore is created by stamping disks with different inner diameters and stacking them to form a series of steps. The MagLab supported the HZB user program by delivering an upgraded B-Coil re-designed in 2016, which improved coil longevity and resulted in zero user down time for the complete year of 2017.

To support smooth operation of the MagLab's resistive magnet program, we have completed fabrication and assembly of 9 spare resistive coils and performed 15 maintenance actions (coil tightening, replacement or other major scheduled tasks) in the resistive magnet cells. In total, 2017 was an exceptionally busy and productive year for the NHMFL Resistive Magnet Program.



**Figure 23:** The new World Record All-Resistive Magnet was tested successfully to full current and generated ~41.4 T peak field for the first time on August 21, 2017. As of Dec 2017, the new magnet user platform has also been completed and the resistive coils were slightly adjusted to secure routine operation up to the full 41.5 T within the 2018 DC user program.

# Chapter 5 – In-house Research

Magnet and Materials

Magnet and Materials

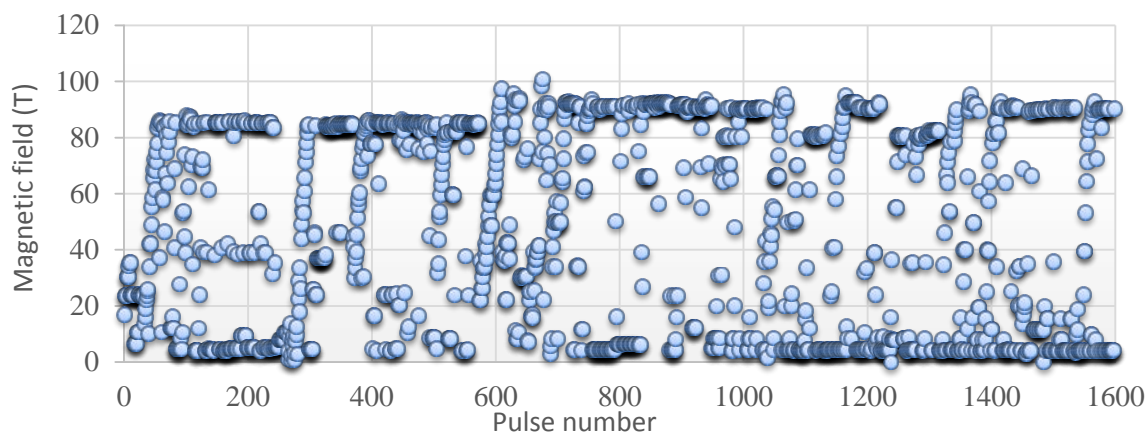

**Figure 24:** (left) Picture of the new duplex magnet built in 2017, (middle) the new duplex cell with user platform and the magnet cryostat housing, (right) illustration of the MOV bank.

## Pulsed Magnets

*The short-pulsed magnets:* In 2017, the four user cells of 65 T workhorse magnets operated near their full capacity to deliver a total of ~ 6500 shots, of which ~2100 shots were 60 T and above. We have successfully maintained the magnets available in all four cells at all times during the year for users and always have a few spare magnets on the shelf. In 2017, seven new magnets have been built and five magnets were damaged providing service to users. Winding of the new 75 T duplex magnet has been completed in March 2017 (**Figure 24** (left)). A new duplex cell with two isolation switches and a new user platform were built next to our 4MJ Cap-bank as shown in **Figure 24** (middle). Since the new duplex magnet will share the capbank with our four 65 T magnets, the switch system must be modified with some added components to minimize the effect of duplex magnet operation on the performance of 65-T magnets. The new switch components were

received at the end of 2017 and are scheduled to be installed in the first quarter of 2018. The duplex magnet consists of two nested magnet coils driven by two separated cap-bank circuits. In the case of a mis-fire, one coil could be energized while the other coil is in open circuit. This situation would create a very high induced voltage on the terminals of the open coil and consequently cause damage to the electronics or switches of the capbank. To avoid this, a bank of Metal Oxide Varistor (MOV) as seen in **Figure 24** (right) was designed and partially tested. A full bank will be assembled and tested in early 2018. The MOV bank will be connected in parallel to the outer coil of the duplex magnet to prevent the overloaded induced voltage at



**Figure 25.** The distribution of magnetic field amplitudes for the 100 T magnet.

# Chapter 5 – In-house Research

## Magnet and Materials

the terminals of this coil. The duplex magnet is scheduled to be tested to deliver full magnetic field in summer 2018.

**100 T magnet system:** So far the 100 T magnet system has delivered a total of nearly 1600 shots. **Figure 25** shows the field attained in the various magnet shots since installation. In 2017, the system delivered 230 shots, of which 62 shots are in the range of 90T and above. Two inserts have been built and used to support users. One of them failed prematurely after delivering only 11 full field shots (>90 T) due to a breakdown of insulation near the bending point of layer #5. After this failure, we modified the insulation technique by adding a Zylon wrap outside the conductor for all 8 layers of the insert coil to mechanically protect the Kapton insulation layers. A few other modifications for the coil winding length and reinforcement layers have been implemented to improve the mechanical performance of the new insert magnet.

**60 T controlled waveform (CW) magnet:** After investigating the failure, we decided to modify the design and rebuild coils # 3, 4, and 7 of the 60 T CW magnet. Instead of winding those coils at a commercial vendor as before, we chose to have those coils wound in

## Magnet and Materials

the NHMFL facility at Tallahassee for better quality control. A close collaboration between the magnet teams at the LANL and FSU campuses enabled great progress for this project. We performed computational and experimental R&D activities to make sure all the modifications of the design and materials for the insulation and reinforcements will improve the coil performance. Fabrication of a model coil for coil #3 as seen in **Figure 26** was completed in July 2017. The test of the coil with a high-voltage cap-bank at LANL indicated that it surpassed all the required specifications. The winding for actual coils #3 and 4 are now underway and should be finished in the second quarter of 2018.

Fabrication of long-length, large cross-section Glidcop AL60 wire for coil 7 is very challenging since a large amount of cold work is required to push the mechanical strength of the wire to the needed threshold. The first attempt for producing wire for coil #7 failed because of the development of Chevron cracks inside the wire during the last die steps of the drawing process. We worked closely with the drawing vendor to modify the drawing speed, lubricant and die schedule to improve the drawing process. The new trial of the modified drawing process for shorter wire length is underway. We expect to complete the production and testing of the wire for coil 7 in the first half of 2018, followed by the construction of coil #7.

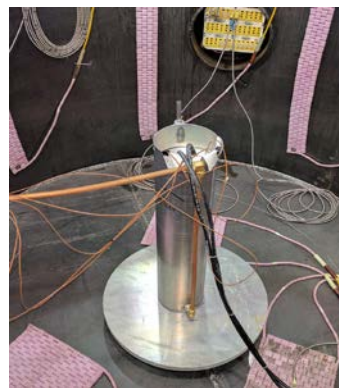
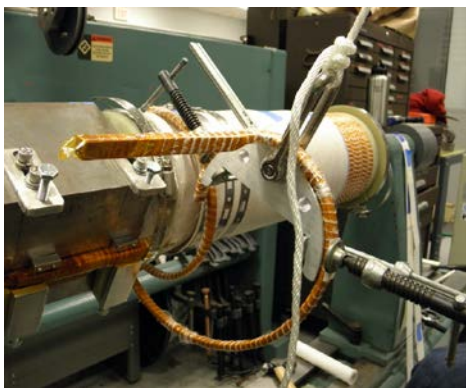

**Figure 26:** (left) Installing the leads for the model coil the MagLab's Tallahassee facility. (right) The model coil is in a chamber during the vacuum pressure impregnation (VPI) process.

# Chapter 5 – In-house Research

## High-Strength Conductors

For decades, the MagLab has been a world leader in high magnetic field research. Maintaining this position has required constantly expanding the underlying science needed to produce innovative components for ever stronger magnets. The MagLab is responsible, for example, for advanced research into the development and application of Cu-matrix composites, whose exceptional combination of strength and electrical conductivity makes them invaluable for both existing and future magnets.

Most Cu-matrix composites lack the strength necessary for use in the strongest magnets, but Cu-Ag and Cu-Nb come close. Together with our partners, we are developing feasible fabrication routes for augmenting the strength of these two composites. Current technologies include casting and deformation. To further optimizing the desirable properties of these composites, we have explored the possibility of casting either with or without magnetic field [1]. The microstructure of cast hypoeutectic Cu-28wt%Ag alloy consists of two parts: an array of Cu-rich proeutectic dendrites and a surrounding Ag-rich eutectic network. We found that the introduction of an external magnetic field during solidification increased both the dendrite arm spacing of proeutectic Cu and the dissolved volume fraction of Ag in the Cu matrix. Super-saturation of Ag resulted in an increase in the density of interfaces between Cu and Ag, both in the proeutectic Cu and in the surrounding eutectic lamellae.

After casting, Cu-Ag composites are customarily cold-deformed to achieve high strength. When our samples were cold-deformed to a true strain of 3.5, those that had been cast under a magnetic field were 5% stronger than those without a magnetic field. This occurred because the magnetic field refined the microstructure, particularly the microstructure within proeutectic Cu. The transversal microstructure of the Cu-Ag composite inherited the network solidification structure, but on a finer scale. At all deformation strains, application of a magnetic field during casting caused both the Ag precipitate spacing and eutectic lamellar spacing to be smaller than would have occurred without a magnetic field.

We have continued to undertake quality control testing of Cu-24wt%Ag and other Cu matrix binary

alloys suitable for user magnets. One of our most important studies gave us the ability to filter out subprime Cu-Zr alloys that proved to be unsuitable. Our other studies of Cu composites contributed to the final commissioning of our world-record 41 T resistive magnet.

In order to reduce costs in the fabrication of high-strength conductors, we explored ternary alloys with lower Ag content. We investigated the effects of Fe content on the microstructure and properties of as-cast and as-drawn Cu-[(5.1-x)vol%Ag-x vol%Fe] alloys (x is the volume fraction of Fe) [2]. When we examined samples in microscale, we observed that increasing Fe content first refined, then coarsened Cu dendrites. In nanoscale, we found that the diameter and length of Ag fiber precipitates in Fe-doped alloys were smaller than those of Ag precipitates in Fe-free alloys. The  $\gamma$ -Fe precipitates in Cu-2.9 vol%Ag-2.4 vol%Fe alloy were finer than the  $\gamma$ -Fe precipitates in Cu-5.1 vol%Fe alloy.

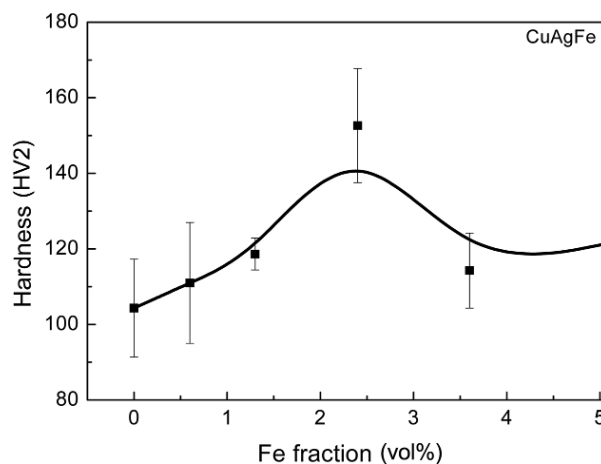

**Figure 27:** The hardness of the Cu-Ag-Fe alloy plotted with different Fe fractions. The vertical axis is the Vicker harness values and horizontal axis is the Fe volume fraction in the alloy.

Using simulation data in our calculation of precipitation hardening, we compared hardness and electrical conductivity among samples with different volume fractions of Fe. The results showed that as the x in Cu-(5.1-x)vol%Ag-x vol%Fe alloys approached 2.4 vol%, the Cu-Ag-Fe composite displayed greater hardness than any of the other samples (Figure 27). This maximum hardness was attributed to the hardening contribution

# Chapter 5 – In-house Research

## Magnet and Materials

from nano-sized precipitates of both Fe and Ag. Increasing drawing strain increased both ultimate tensile strength and hardness of Cu-Ag-Fe composites. As a small amount of Ag was replaced by Fe, electrical conductivity decreased on a descending slope of approximately 3%IACS (International Annealed Copper Standard) per vol% Fe. Once 2.4 vol%Ag had been replaced by Fe, however, the rate of change reduced to almost 0% and the electrical conductivity became invariant, remaining the same regardless of any increased Fe content. After annealing at 450 °C for 4 h, the electrical conductivity of Cu-2.9 vol%Ag-2.4 vol%Fe composite shot up from 39 %IACS to 68 %IACS. We also revisited our previous studies of Cu-Nb composites. We were able, by improving the annealing and drawing procedures, to reproduce Cu-Nb conductor wires with an intermediate cross-section area of  $\sim 17 \text{ mm}^2$  and a large cross-section area greater than  $30 \text{ mm}^2$ . The wires of  $17 \text{ mm}^2$  are used for short pulsed magnets and for the inner coils of the current generation 100 T pulsed magnet. The wires of  $30 \text{ mm}^2$  + will be used for the outer coils of the proposed, next generation 100 T+ pulsed magnet.

### References

References generated by endnote

- [1] C.C. Zhao, X.W. Zuo, E.G. Wang, K. Han, *Metals and Materials International* 23 (2017) 369-377.
- [2] X.W. Zuo, J.Z. Zhu, B.L. An, K. Han, R. Li, E.G. Wang, *Metals and Materials International* 23 (2017) 974-983.

### LTS Magnets and Materials

#### FSU Series-Connected Hybrid

The Series Connected Hybrid (SCH) is the NHMFL's newest magnet that is now available to users. The primary application is for condensed matter NMR at intense fields. It is designed to provide a magnetic field of up to 36 T at a homogeneity of 1 ppm; a combination that is unique to this facility. Late in 2016, the SC magnet was brought to full field for the first time. Commissioning of this magnet system was the focus in 2017 by improving the cryogenic and electrical operational conditions and parameters, adjusting field uniformity and stability, demonstration of the NMR probes, and introducing an insert cryostat for condensed matter physics.

## Magnet and Materials

The SCH is a complex magnet system consisting of a 13 T cable-in-conduit coil that is cooled with 4.5 K forced flow supercritical helium outside of a 23 T Florida-Bitter resistive coil set. Many new features are implemented here, including 20 kA current leads utilizing an HTS section operating in the fringe-field of the magnet while cooled with liquid nitrogen and a modern superconducting/resistive magnet protection system with a central digital field programmable gate array. These subsystems, and others, have undergone several adjustments to improve robustness and operability in an effort to reduce user disruption.



**Figure 28:** The Series-Connected Hybrid (background) with iron shield installed and personnel monitoring the system during magnet testing.

The raw magnet uniformity after the early operations was greater than 100 ppm over 1 cm DSV, which was expected. This was dominated by a linear term which was reduced to 25 ppm by moving the resistive coils upward 1.0 mm from their initial location. The addition of six ferromagnetic and resistive shims in the sample probes further reduced the inhomogeneity to 1 ppm. The temporal stability has been improved by using a modified Bruker NMR lock that is operating on an external doped  $^7\text{Li}$  lock sample. Development is underway to further improve the stability by employing an integrated NMR lock with magnetic field flux stabilization.

# Chapter 5 – In-house Research

Magnet and Materials

Magnet and Materials

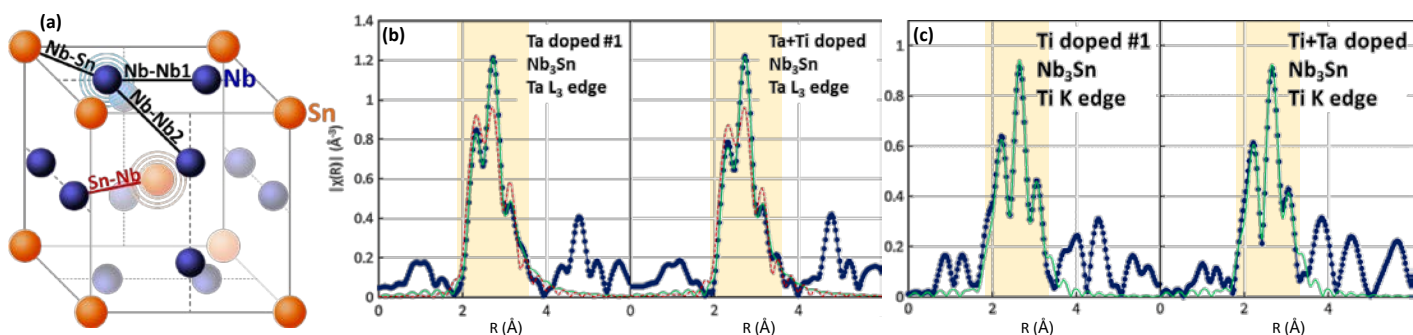

**Figure 29:** (a)  $Nb_3Sn$  structure schematic with its three nearby coordination shells for Nb (blue) and a single nearby shell for Sn (orange). (b) and (c) Fourier transforms of the  $k^2$  weighted  $\chi(k)$  EXAFS data for the Ta  $L_3$  and the Ti K edges. The blue points and line are the data, the green curve is a two-site fit, and the red dashed curve is a fit to the Nb site only (yellow areas show the fitting windows).

Three probes are now available for NMR spectroscopy. These include a triple-resonance HXY 2.0 mm MAS probe, a double-resonance HX static probe, and a single-resonance 3.2 mm MAS probe. While the majority of users on the SCH were for NMR experiments, four weeks were dedicated in 2017 for condensed matter physics. For this a new  $^3He$  cryostat was installed in the SCH.

## LTS Conductor Optimization

High critical current density,  $J_c$ ,  $Nb_3Sn$  wire ( $J_c \geq 2500$  A/mm<sup>2</sup>, 12 T/4.2 K) can be manufactured by the internal Sn (IT) or powder in tube (PIT) processes. Our studies, primarily sponsored by the US DOE and CERN, are aimed at improving the properties of both types primarily for applications in high energy physics that require magnetic fields higher than 15 T. Our recent studies reported last year have resulted in significant enhancement of the non-Cu critical current density of IT-based “RRP” wires produced by Bruker-OST by simply changing the heat treatment that the wire undergoes. However, for magnet applications at fields above 15 T, such as NMR spectroscopy, compact cyclotrons, and the next generation of particle accelerators, like the envisioned Future Circular Collider (FCC), further improvements in the high-field performance are necessary. Since doping of  $Nb_3Sn$  by Ti or Ta is required to achieve a high upper critical field,  $H_{c2}$ , we are investigating the precise dopant occupancy to probe the limits of  $H_{c2}$ . We have also studied new designs of PIT wires produced by Bruker-EAS, which could potentially

be used for high field applications. These new designs have produced high  $J_c$  values while maintaining the high purity of the Cu stabilizer required for magnet stability. However, the newly designed wires have different responses to mechanical deformation, which affects the  $Nb_3Sn$  phase formation and the resulting transport performance.

### 1. RRP: Potential Route for $H_{c2}$ enhancement

To investigate the site dopant occupancy in  $Nb_3Sn$ , we performed extended x-ray absorption fine structure (EXAFS) studies on Ti-, Ta- and Ta+Ti-doped high- $J_c$  RRP wires in collaboration with Steve Heald at the Advanced Photon Source at ANL. We have correlated those results to microstructural/ microchemical analyses and specific heat measurements performed at the NHMFL. EXAFS is sensitive to the local environment of the dopant atoms. It occurs at x-ray energies above the absorption edge energy of the element under study. Thus, by tuning the x-ray energy to different absorption edges, the local structure of individual elements in a complex material can be determined. In  $Nb_3Sn$  there is a distinct difference in the local environment of the two sites (see **Figure 29(a)**) with Nb having three closely spaced nearby coordination shells, while the Sn site having only a single nearest neighbor shell. This produces a distinct 3-peak structure in the Fourier transformed spectra for the Nb site and a single peak for the Sn site in the  $R \sim 1.9-3.5$  Å range of the spectra. For Ta doping (**Figure 29(b)**), we found the 3-peak structure of the Nb sites, indicating that most Ta is on this site. However, the

# Chapter 5 – In-house Research

## Magnet and Materials

best fits were obtained with ~30-32% of Ta occupying the Sn sites (solid green lines). For the Ti doping, the Ti occupancy on the Sn site in the two-site fit always refined to 0 indicating a strong preference for the Nb site. EDS characterization of those samples shows that

1.5  $\mu\text{m}$  (4.2% of diameter)

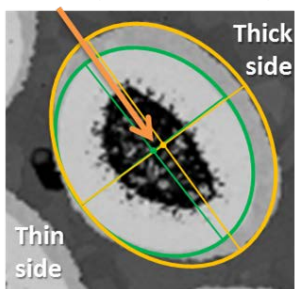

72 nm (0.2% diameter)

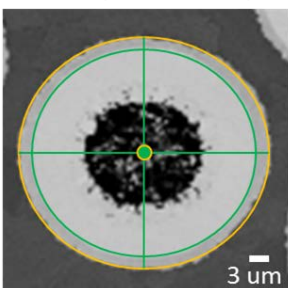

**Figure 30:** Example of centroid offset which caused a leak (top), and an intact filament with little core drift

dopants themselves, but an essential contribution comes from the antisite disorder (Nb on Sn site or vice versa) that the dopants induce. Moreover, we suggest that dual-doped strands should be re-explored for 16-20 T applications investigating both the dopant levels and the optimal heat treatment [5.LTS.2].

### 2. PIT: Effect of Wire Drawing on the A15 Production

In PIT Nb<sub>3</sub>Sn wires, asymmetry in the filament cross-sections produced during wire fabrication creates an uneven A15 reaction front, causing the A15 to react through the diffusion barrier (DB) on the thinnest side, while allowing an excessive layer thickness elsewhere. This results in lost critical current density and suppress Residual Resistance Ratio (RRR). Once the DB is reacted through, the RRR of the strand is compromised and further reaction of the filament is limited. Recently, we

Ti-doped wires are chemically more homogeneous than those doped with Ta ones. However, these new site occupancy results show that the Ti-doped Nb<sub>3</sub>Sn layers are strongly sub-stoichiometric in Sn. Specific heat and transport characterizations reveal that Ti also generates a narrower  $T_c$  distribution and a larger  $H_{c2}$  and Kramer field  $H_{irr}$  than Ta. We also investigate dual-doped Ta+Ti strands and found that, despite a quite broad 0 T  $T_c$ -distribution, dual doping produced a better high field performance than either Ta and Ti doped wires.

Applying this new data to the Besson *et al.* the ab initio calculation [5.LTS.1], we conclude that  $H_{c2}$  is not simply determined by the disorder introduced by the

## Magnet and Materials

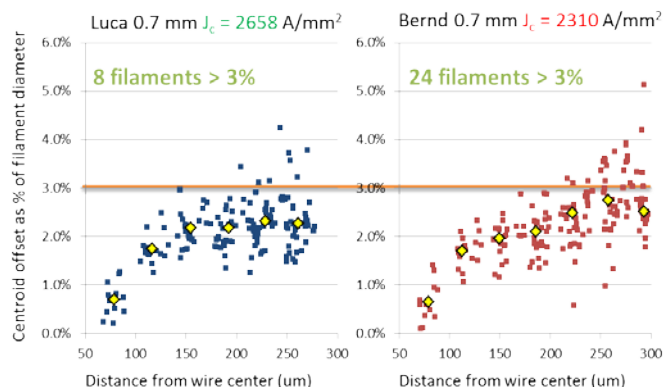

**Figure 31:** Centroid offset normalized to the diameter of each filament, plotted against its radial distance from the wire center. The yellow data points are a local average of the filaments within each filament ring.

found that the undesired uneven reaction front is related to the Sn-rich core drifting from the center of its Nb-Ta reaction tube because the A15 reaction proceeds radially outward from the filament the Sn-rich core (see **Figure 30**).

To overcome the RRR issue and to increase the Sn content in order to increase the A15 formation, Bruker EAS redesigned their wires introducing a “bundle barrier” around the filaments to protect the external Cu stabilizer. We performed a detailed analysis on two of these wires. We found that that the addition of the bundle barrier increased non-uniform filament reduction during wire drawing, causing the outer filaments to be substantially smaller than the inner filaments, reducing the filament (and A15) area by up to 30% in the outer filaments compared to the inner filaments. We also observed that the core of the filament tube was moving away from the center of the filament in some filaments. We quantified this “centroid drift” taking into account the variation in filament size within a wire, to calculate a centroid offset that is normalized to the effective diameter of each filament. **Figure 31** shows the centroid offset as a function of filament distance from the wire center for a high- $J_c$  and a low- $J_c$  0.7 mm wires. Clearly the highest  $J_c$  wire has less filaments affected by a strong offset (>3%) making it less susceptible to leakages. This allows a larger A15 phase formation and so a higher non-Cu  $J_c$ .

These detailed studies of state-of-the-art PIT wires have taught us much about the sensitivity of the



# Chapter 5 – In-house Research

final cross-sections to non-uniform deformation during wire fabrication that we believe rob PIT of its potential.

### 3. High Vortex Pin Density in $Nb_3Sn$

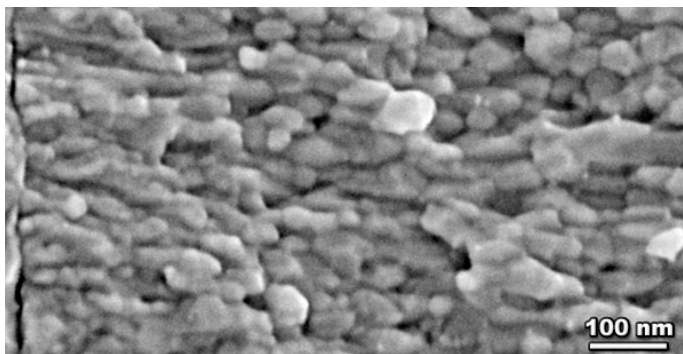

**Figure 32:** Sub-100 nm  $Nb_3Sn$  grain size in SupraMagnetics Nb1Zr PIT. Two-stage HT: 24 h/500 °C+200 h/640 °C.

In collaboration with Leszek Motowidlo (SupraMagnetics) and Arup Ghosh (BNL) we performed an extensive characterization of PIT  $Nb_3Sn$  wires with artificial pinning centers (APC) produced by Motowidlo. In conventional  $Nb_3Sn$ , only the grain boundaries act as vortex pinning centers limiting their density to much less than optimal (the average grain size is in the 90-150 nm range, whereas the equilibrium fluxoid spacing at 16 T is only ~12 nm). Despite numerous attempts to introduce APC, only General Electric (GE) [5.LTS.3] had some success in tapes. By doping their Nb tape substrate with Zr that was subsequently oxidized to form  $ZrO_2$  precipitates they were able to reduce the grain size of  $Nb_3Sn$  to ~50 nm. Attempts to adapt this approach to wires had not been successful until recently when Xu *et al.* obtained positive results but with an approach not suitable for long-length HEP conductors [5.LTS.4]. SupraMagnetics instead adapted their established Powder-in-Tube process, which uses a  $Cu_3Sn_4$  powder core, by adding  $SnO_2$  to the core and substituting Nb1Zr tubes for the Nb-Ta tubes. This approach, which is much closer to designs of conventional HEP  $Nb_3Sn$  conductors, was successful in producing grain sizes of 30-50 nm (see **Figure 32**) and shifting the pinning force curves from grain boundary to point pinning behavior [5.LTS.5]. Although this technique appears promising, further investigations are in progress to enhance  $H_{c2}$  and  $H_{irr}$  by adding dopant

elements that are known to enhance the high field properties.

### References

- [5.LTS.1] Besson R, Guyot S and Legris A 2007 Atomic-scale study of diffusion in A15  $Nb_3Sn$ . *Physical Review B* **75**, 054105.
- [5.LTS.2] Heald S M, Tarantini C, Lee P J, Brown M, Sung Z-H, Ghosh A K, Larbalestier D C (2018) Evidence from EXAFS for Different Ta/Ti Site Occupancy in High Critical Current Density  $Nb_3Sn$  Superconductor Wires. Under review.
- [5.LTS.3] Rumaner L E, Benz M G and Hall E L 1994 The role of oxygen and zirconium in the formation and growth of  $Nb_3Sn$  grains *Metallurgical and Materials Transactions A* **25** 213–219.
- [5.LTS.4] Xu X, Sumption M, Peng X and Collings E W 2014 Refinement of  $Nb_3Sn$  grain size by the generation of  $ZrO_2$  precipitates in  $Nb_3Sn$  wires *Applied Physics Letters* **104** 082602.
- [5.LTS.5] Motowidlo L R, Lee P J, Tarantini C, Balachandran S, Ghosh A K and Larbalestier D C 2018 An intermetallic powder-in-tube approach to increased flux-pinning in  $Nb_3Sn$  by internal oxidation of Zr *Supercond. Sci. Technol.* **31** 014002.

### Structural Materials for LTS Magnets

High-strength structural materials are required for both reinforcement and structural components in high field magnets. Austenitic stainless steel 316 is one of the most important high-strength materials used for these purposes. In recent years, research has been focused on investigating and developing alloys with both high mechanical strength and high resistance to fracture propagation (fracture toughness). High magnetic fields and high electrical current often generate levels of stress that exceed the strength currently achievable in 316 -type stainless steels. We have undertaken cryogenic (4 K) tests of tensile strength, fatigue-crack growth-rate, and fracture toughness on 316 LN, Nitronic® 50, and JK2LB austenite stainless steels[1]. The data show that JK2LB exhibited high toughness, whereas Nitronic® 50 generally exhibited higher strength, but lower toughness, than JK2LB.

# Chapter 5 – In-house Research

Properties of steels are affected by inclusion distribution and microstructure, both of which are controlled by fabrication routes. We studied the evolution of inclusions in steel made by a new pre-alloying method[2]. We found that MnO-FeO inclusions formed as a by-product of pre-alloying. The evolution of the oxide is as follows: spherical Fe-rich inclusions ( $3\text{FeO}\cdot\text{MnO}$ ) become shelled Fe-rich, low-melting point  $3\text{FeO}\cdot\text{MnO}$  in the core and Mn-rich, high-melting point  $\text{FeO}\cdot\text{zMnO}$  on the surface of the shell. Some of these shelled inclusions transform to spherical Mn-rich  $\text{FeO}\cdot\text{zMnO}$  particles. We investigated the impact of high magnetic fields on the microstructure and properties of steels, and we found that under certain heat treatment conditions, a magnetic field can refine the microstructure and improve the properties of steels[3]. These findings, reported in 2017, are useful in studying control of microstructure in steels, including the shape and size of inclusions.

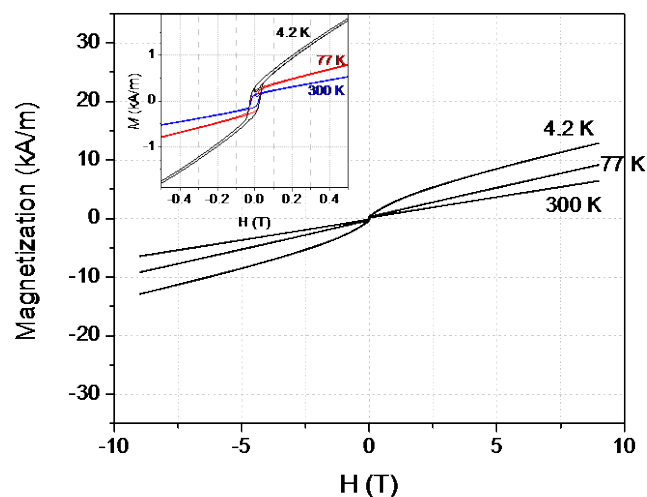

**Figure 33:** Magnetization versus magnetic field which is parallel to rolling direction for an aged Co-35Ni-20Cr-10Mo sample. The inset in the figure is a close-up showing hysteresis indicating ferromagnetism.

Based on our experience with high-strength alloys, we began several years ago to investigate multiphase Co-35Ni-20Cr-10Mo alloy, which has higher strength and higher modulus than austenitic stainless steels and thus has an excellent potential for application as reinforcement material in high-field superconducting magnets[4, 5]. For these applications, accurate measurement of physical properties at cryogenic temperatures is very important. We have measured the properties of as-received and aged samples at temperatures ranging from 2 to 300 K[6]. The electrical resistivity of aged samples tends to be slightly higher than that of as-received samples. In both cases, a weak linear temperature dependence has been observed throughout the entire range of 2–300 K. The magnetic property of the alloy changes significantly with aging. The as-received sample exhibited Curie paramagnetism with the Curie constant ( $C = 0.175$  K). The aged sample contained, in addition to its Curie paramagnetism, showed a small amount of ferromagnetic phase at both cryogenic and room temperatures (**Figure 33**). These measured multiphase alloy properties will be useful for the future design of both pulsed and superconducting magnets.

## References

### Citations generated by end note

- [1] D.M. McRae, S. Balachandran, R.P. Walsh, IOP Conference Series: Materials Science and Engineering 279 (2017) 012001.
- [2] F.J. Li, H.G. Li, S.B. Zheng, J.L. You, K. Han, Q.J. Zhai, Materials 10 (2017).
- [3] K. Han, X.L. Zhou, Materials and Manufacturing Processes 32 (2017) 1317-1324.
- [4] V.J. Toplosky, K. Han, Mechanical Properties of Cold-Rolled and Aged MP35N Alloys for Cryogenic Magnet Applications, in: U. Balachandran (Ed.) Advances in Cryogenic Engineering, Vol 58, vol 1435, 2012, pp. 125-132.
- [5] K. Han, V.J. Toplosky, J. Lu, Y. Xin, R.E. Goddard, R.P. Walsh, I.R. Dixon, IEEE Transactions on Applied Superconductivity 23 (2013).
- [6] J. Lu, V.J. Toplosky, R.E. Goddard, K. Han, Cryogenics 86 (2017) 106-111.

# Chapter 5 – In-house Research

CMS

CMS

## 5.2. Condensed Matter Science

5.2.1. Bright-Dark Exciton Splitting in Monolayer MoSe<sub>2</sub>  
Zhengguang Lu, Seonghill Moon (NHMFL, FSU Physics);  
Daniel Rhodes; James Hone (Columbia U); Dmitry Smirnov (NHMFL)

### Introduction

Atomically thin group-VIB transition metal dichalcogenides (TMDs) have recently attracted vast interest as a new class of gapped semiconductors. When TMDs are thinned down from bulk to monolayers, a striking change in their electronic structure is the crossover from indirect to a direct band gap at the degenerate but inequivalent K and -K valleys at the corners of the hexagonal Brillouin zone. Since the conduction band (CB) edges at K/-K valleys are spin-split, the lowest energy excitonic state could be optically bright or dark depending on the nature of relevant spin-allowed or spin-forbidden transitions. Application of an external in-plane magnetic field mixes the components of the spin-split CB, thus brightening the originally dark excitons. Magnetic field brightening of dark excitons has been observed in WSe<sub>2</sub> monolayers [1], although the magnetic field induced splitting of bright and dark exciton in TMDs remains unexplored.

### Experimental

The experiments were performed on a MoSe<sub>2</sub> monolayer encapsulated by h-BN. The photoluminescence and reflectance spectra were measured in Voigt geometry using a direct-optics micro-spectroscopy setup coupled either to the 14.5T (EMR facility) or 17.5T (DC field facility) superconducting magnet.

### Results and Discussion

The PL spectrum of MoSe<sub>2</sub>/hBN features two peaks corresponding to the emission from bright neutral and negatively charged excitons. The in-plane magnetic field brightens the spin-forbidden neutral dark exciton making it clearly distinguishable at B>10T. The energy separation between bright and dark excitons varies quadratically with the magnetic field strength, consistent with theoretical expectations, in which the CB spin is linearly perturbed by the in-plane magnetic field. However, this simple model does not explain two important experimental observations: (i) the asymmetry of bright and dark exciton branches, (ii) the deviation

from the B<sup>2</sup> behavior of exciton branches that appears in reflectance spectra at high fields above 14-15T.

### Conclusions

PL and reflectance spectroscopy measurements on h-BN encapsulated MoSe<sub>2</sub> monolayers performed with in-plane magnetic fields up to 17.5T reveal the effect of bright-dark exciton splitting. Further measurements at higher fields are needed to investigate the high-field anomalies of the splitting.

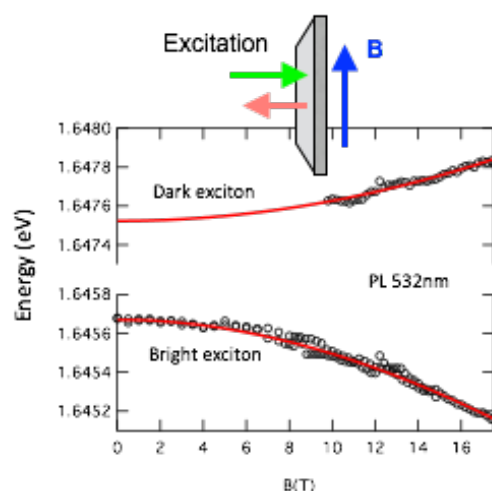

**Figure 1:** Splitting of dark and bright excitons of monolayer MoSe<sub>2</sub> as a function of in-plane magnetic field. Symbols represent the energies of PL peaks measured with non-resonant excitation.

### Acknowledgements

Z.J., S.M. and D.S. acknowledge the support from the U.S. Department of Energy (grant number DE-FG02-07ER46451) and the NHMFL User Collaboration Grants Program (grant UCGP No. 5087). A portion of this work was performed at the National High Magnetic Field Laboratory, which is supported by National Science Foundation Cooperative Agreement No. DMR-1157490 and the State of Florida.

### References

[1]Zhang, X.-X.; Cao, T.; Lu, Z.; Lin, Y.-C.; Zhang, F.; Wang, Y.; Li, Z.; Hone, J.C.; Robinson, J.A.; Smirnov, D.; Louie, S.G. and Heinz, T.F., *Magnetic brightening and control of dark excitons in monolayer WSe<sub>2</sub>*, **Nature Nanotechnology**, **12**, 883 (2017)

# Chapter 5 – In-house Research

CMS

CMS

## 5.2.2. Fermi Surface measurements of underdoped YBCO under pressure

A. Grockowiak, W.A. Coniglio, (NHMFL), D.A. Bonn, W.N. Hardy, R. Liang (UBC), C. Proust (LNCMI), L. Taillefer, N. Doiron-Leyraud ( Université de Sherbrooke), S.W. Tozer (NHMFL)

### Introduction

We are looking at the evolution of the Fermi Surface and effective masses of YBCO6.50 across the superconducting dome, using pressure as a tuning parameter of the ground state.

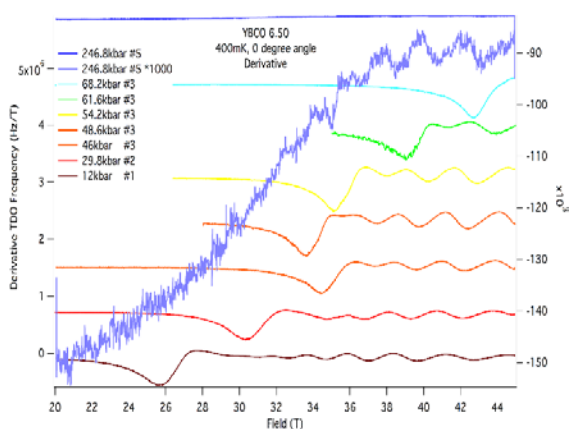

Figure 2

### Experimental

Quantum Oscillations (QO) were measured using a Tunnel Diode Oscillator (TDO) setup coupled with Diamond Anvil Cell to probe pressures up to 25GPa in the 45T Hybrid at the NHMFL-Tallahassee.

### Results and Discussion

Figure 2 shows the derivative of the TDO frequency as a function of magnetic field from 1.2GPa up to 25GPa at  $^3\text{He}$  base temperature. Clear QO appear after a dip at 26T at 1.2GPa identified as  $H_{c2}$ . Temperature dependence of the QO yielded effective masses via a Lifshitz-Kosevich (LK) fit.  $H_{c2}$ ,  $T_c$  at 0 and 16T, the frequency of the QO as well as the effective mass are plotted on Figure 3 as a function of pressure. The frequencies and effective masses observed are in good agreement with the values obtained for a doping

dependence study (see [1] for example). A clear divergence in the frequency and the effective mass is observed around 4.5GPa, along with a drop in  $H_{c2}$ . This is interpreted as the maximum of the charge order, also corresponding to the shoulder in the superconducting dome.

QO were also measured on a sample at 25GPa, and neither  $H_{c2}$  nor  $T_c$  was measured on that sample, indicating that the sample has been pushed to the overdoped side of the superconducting dome. The frequency of these oscillations of about 695T is in complete disagreement with the reported 18kT frequency of  $\text{TlBa}_2\text{CuO}_{6+}$  [2] which, up to this time, has been the accepted analogue sample to the overdoped region of YBCO.

### Conclusions

We are successfully mapping the pressure-field phase diagram of YBCO to look at Fermi Surface reconstruction as a function of pressure. We have observed the suppression of the charge order with pressure, and made the first measurement of QO on the overdoped side of the dome, with results strikingly different from the reported literature values.

### Acknowledgements

This work was performed at the National High Magnetic Field Laboratory, supported by National Science Foundation Cooperative Agreement No. DMR-1157490 and the State of Florida.), and funded by the Center for Actinide Science and Technology (CAST), an EFRC funded by the U.S. DOE, BES, Award No. DE-SC0016568

### References

- [1] Ramshaw, B. J. et al. *Science* **348** 317-320 (2015)
- [2] Vignolle, B. et al., *Nature Letters* **455** (2008)

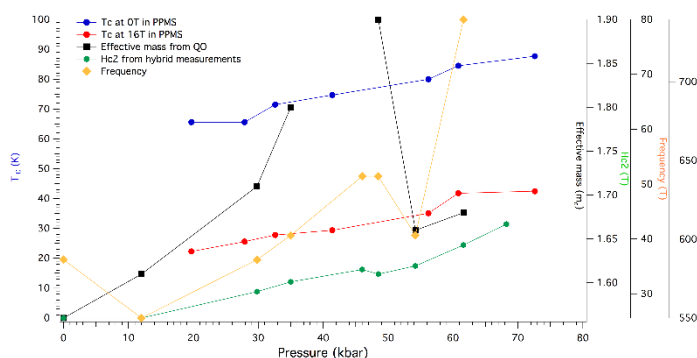

Figure 3

# Chapter 5 – In-house Research

CMS

Experimental

CMS

## 5.2.3. Probing the Fermi surface and g-factor anisotropy in electron doped URu<sub>2</sub>Si<sub>2</sub>: Measurements to 45 Tesla at dilution refrigerator temperatures

Huang, K. and Graf, D. and Park, J.-H. (NHMFL); Chen, K.-W. and Lai, Y., and Baumbach, R. E (FSU, Physics)

### Introduction

The hidden order (HO) state in URu<sub>2</sub>Si<sub>2</sub> has been the focus of considerable research since its initial discovery over three decades ago, with a plethora of theoretical models proposed to describe it.[see Refs. in 1] These models are based upon the f-electrons behaving either as itinerant or localized electrons, but experimental evidence remains inconclusive. Quantum oscillation and ARPES experiments suggests a link between HO and the partial gapping of the U atoms 5f bands near the Fermi surface, suggesting the itinerant scenario.[2] However, a large g-factor anisotropy was also observed, reminiscent of localized electron behavior. [3]

To address this duality, we performed magnetoresistance measurements on the chemically substituted system URu<sub>2</sub>Si<sub>2-x</sub>P<sub>x</sub>, where increasing x suppresses HO, possibly through electron doping.[4], This study sheds light on the HO state in two ways: (1) Quantum oscillation measurements probe the Fermi surface (FS) and determine how it evolves as the system changes from the HO state to a no-ordered state with increasing x. (2) the angular dependence of the magnetoresistance allows us to indirectly track how the g-factor anisotropy evolves as the HO is suppressed with increasing x.

Magnetoresistance measurements were performed using the Hybrid 45 T magnet, 32mm bore (cell 15), in a dilution refrigerator on oriented single crystals of URu<sub>2</sub>Si<sub>2-x</sub>P<sub>x</sub>, x = 0, 0.006, 0.01, 0.02, and 0.102, where x = 0.102 is in the region where HO was fully suppressed. The measurements went down to a base temperature of T = 70 mK with H // [001] (θ = 0°), and at select angles up to θ = 120° where θ = 90° was H // [100] direction as well as up to T = 760 mK for θ = 90° and 76°.

### Results and Discussion

Quantum oscillations are observed in all samples except for x = 0.102, with the most pronounced oscillations centered on θ = 90°. From the angular dependence of the measurements, we find that the FS anisotropy is consistent throughout the HO region. We also find that the critical magnetic fields of the high-field magnetic ordered phases also share the same anisotropy, regardless of x.

From the temperature sweeps at θ = 76° and 90°, the effective mass (m<sub>eff</sub>) was determined in samples with x up to 0.2 from the amplitude of the FFT of the magnetoresistance. Interestingly, m<sub>eff</sub> from the θ branch displays a maximum at x = 0.01, similar to the entropy profile observed from specific heat in reported literature.[4]

### Conclusions

From magnetoresistance measurements we find that within the HO region the main FS features and the g-factor anisotropy is mostly independent of x, Interestingly, m<sub>eff</sub> appears to peak at x = 0.01, possibly suggesting an electronic instability centered near this concentration.

### Acknowledgements

A portion of this work was performed at the National High Magnetic Field Laboratory, which is supported by National Science Foundation Cooperative Agreement No. DMR-1157490 and the State of Florida.

### References

- [1]Mydosh, J. A., *et al.*, *Phil. Mag.* **94**, 3642-3662 (2014).
- [2]Santander-Syro, A. F. *et al.*, *Nat. Phys.* **5**, 637-641 (2009)
- [3]Altarawneh, M. M. *et al.*, *Phys. Rev. Lett.*, **108**, 066407 1-4 (2012),
- [4]Gallagher, A. *et al.*, *Nat. Comm.*, **7**, 10712 1-5 (2016)

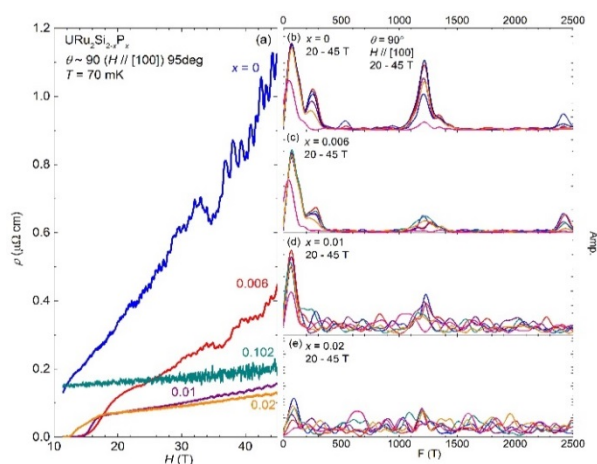

**Figure 4** (a) Magnetoresistance measurements in URu<sub>2</sub>Si<sub>2-x</sub>P<sub>x</sub> with quantum oscillations observed up to x = 0.02. (b)-(e) FFT of the oscillations.

# Chapter 5 – In-house Research

CMS

CMS

## 5.2.4. Anisotropy Study of Magnetothermal Conductivity of $\text{Co}_4\text{Nb}_2\text{O}_9$

Benjamin, S.M.; Baek, H and Choi, E.S. (NHMFL), Zhou, H. (Univ. of Tennessee, Physics)

### Introduction

We have measured magnetothermal conductivity of  $\text{Co}_4\text{Nb}_2\text{O}_9$ , which shows large magnetoelectric effect in the magnetically ordered state. Previously, we discovered the magnetothermal conductivity shows rapid increase at temperatures below 1 K when a very small field ( $H < 1$  T) is applied in the ab-plane. In the present study, we measured its field orientation dependence for two different directions of  $H// [1\bar{1}0]$  and  $H// [001]$ . It is reported that the magnetic easy axis is parallel with  $[1\bar{1}0]$  and the spin flop field is around 0.1 T [1].

### Experimental

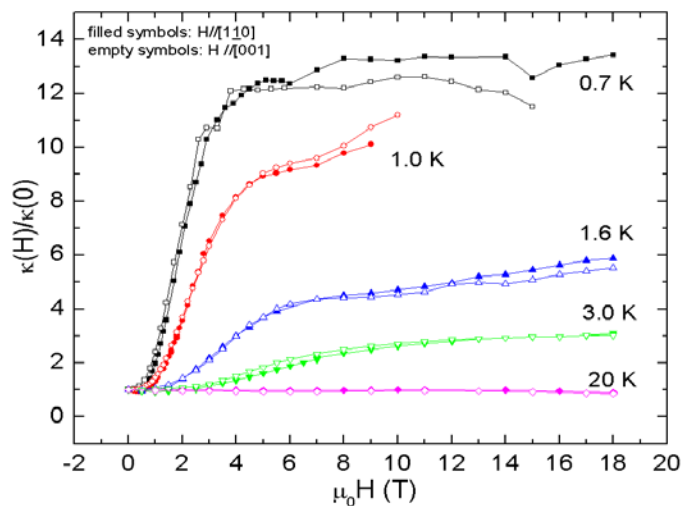

**Figure 5:** Magnetothermal conductivity of  $\text{Co}_4\text{Nb}_2\text{O}_9$  at different temperatures. Data for field directions are shown.

The two-sensor-one-heater method was used on a single crystalline  $\text{Co}_4\text{Nb}_2\text{O}_9$  sample placed in a vacuum cell. The heat conduction is maintained along the  $[1\bar{1}0]$  direction while the magnetic field is varied using the SCM2 rotator probe.

### Results and Discussion

**Figure 5** shows the magnetothermal conductivity (MTC,  $\kappa(H)/\kappa(0)$ ) at different temperatures for the two different field directions. The overall behavior of the MTC is independent of the field direction. This isotropic behavior at the wide range of

temperature is somewhat unexpected, because we speculated the rapid increase of the thermal conductivity was related to a contribution of magnons to the heat transport, which is bound to be sensitive to the magnetic field direction. One possible alternative explanation is that the magnetic field suppresses the spin-phonon scattering term, hence recovers the presumably higher phonon thermal conductivity [2]. The temperature dependence of thermal conductivity (shown in **Figure 6**) may seem to support this idea, as the magnon-phonon resonant scattering peak increases with field. However, the fact that the rapid increase of the MTC is more significant at very low temperatures where the temperature is too low to satisfy the resonant condition is still puzzling. Further analyses are required to explain the isotropic increase of MTC as well as the negative MTC at high temperatures.

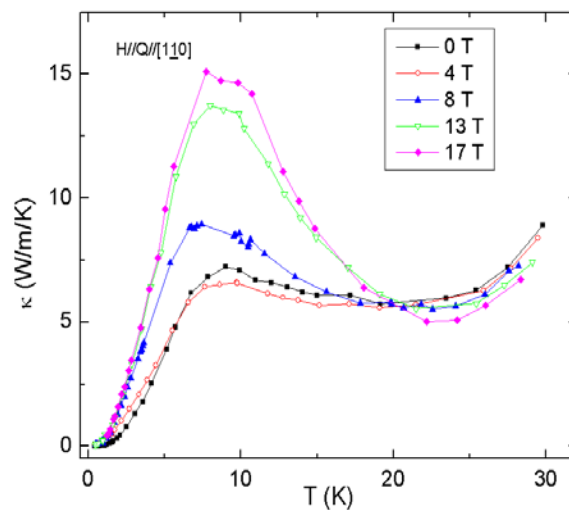

**Figure 6:** Temperature dependence of thermal conductivity of  $\text{Co}_4\text{Nb}_2\text{O}_9$  at different fields. Magnetic field is applied along  $[110]$  direction.

### Acknowledgements

This work was performed at the NHMFL, which is supported by NSF (DMR-1157490) and the State of Florida. We acknowledge additional support by NSF-DMR 1309146.

### References

- [1] Khanh, N. D. *et al.*, Physical Review B, **93**, 075117, (2016).
- [2] Zhao, X. *et al.*, Applied Physics Letters, **108**, 242405, (2016).

# Chapter 5 – In-house Research

CMS

CMS

## 5.2.5. Fermi surface study of the Weyl type-II metallic candidate $WP_2$

Schoenemann, R. and Balicas, L. (National High Magnetic Field Laboratory)

### Introduction

$WP_2$  was predicted to be a Weyl type-II semimetal with robust Weyl points located at about 0.4 eV below the Fermi level [1]. Unlike the transition metal dichalcogenides like (Mo, W)Te<sub>2</sub>,  $WP_2$  does not have a layered structure and belongs to the non-centrosymmetric space group Cmc2<sub>1</sub>.

### Experimental

AC transport experiments on  $WP_2$  single crystals have been conducted in a <sup>3</sup>He cryostat in cell 12 up to 34.5 T using a rotator probe. At the highest measured MR in any compound. Simultaneously the samples show high residual resistivity conventional four terminal method was used to measure the sample resistance.

### Results and Discussion

The measured  $WP_2$  single crystals show an exceptionally high anisotropic magneto resistance (MR) – up to  $25 \cdot 10^6\%$  at 34.5 T and 0.35 (see **Figure 7**) – so ratios (up to 20000) and low residual resistivities of 10nΩcm. We obtained effective masses for fields along the b-axis between 0.7 and 1.1 bare electron masses. A full angular dependence of Shubnikov-de Haas (SdH) oscillations has been measured and compared with bandstructure calculations which showed good agreement when shifting individual bands by  $\pm 30$  meV (**Figure 7**).

### Conclusions

We were able to confirm the theoretical predicted bandstructure of  $WP_2$  via SdH measurements. The relatively high effective masses of charge carriers indicate a significant curvature of bands at the Fermi

level. The small shift of bands with respect to the Fermi energy might also have implications to the underlying Weyl points. The results have been published in Ref. [2].

### Acknowledgements

This work was supported by DOE-BES through Award N. DE-SC0002613. A portion of this work was performed at the National High Magnetic Field Laboratory, which is supported by National Science Foundation Cooperative Agreement No. DMR-1157490 and the State of Florida.

### References

- [1]Autes, G. *et al.*, *Phys. Rev. Lett.* **117**, 066402 (2016).
- [2]Schoenemann, R. *et al.*, *Phys. Rev. B* **96**, 121108(R) (2017)

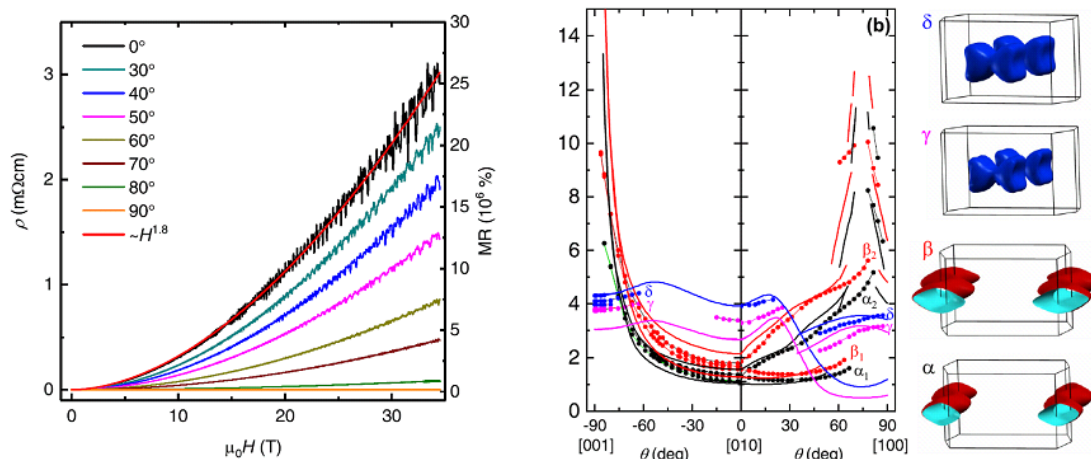

**Figure 7:** Left: Field dependence of the resistivity of a  $WP_2$  single crystal for different angles ( $0^\circ = H \parallel b$ ). Right: Angular dependence of SdH frequencies (dots) and predictions by DFT calculations (solid lines). Branches that belong to individual hole (red) and electron (blue) pockets are labeled with Greek letters.

# Chapter 5 – In-house Research

CMS

CMS

## 5.2.6. Two-Axis Rotation Using a Piezo-Driven Platform *Graf, D. (NHMFL)*

### Introduction

The capability to change the orientation of crystals with respect to an applied magnetic field in both the  $\theta$  and  $\phi$  directions (spherical coordinates) *in situ* at low temperatures can be a critical factor in an experiment. All of the magnets of the DC field user program have “single-axis” probes which will rotate samples in the  $\theta$  direction [1]. Several methods have been attempted in the past for shifting the angle  $\phi$ . One technique involves rotation which is gear driven and therefore has difficulty in maintaining low temperatures due to heating created from friction. A second method has been to implement a piezo rotation platform (PRP) where commercial units have, as proven with magnet time in SCM2, proven to be unreliable and are costly to replace.

### Experimental

As an alternative to purchasing PRPs from outside vendors, a summer intern, Chris Mann, built a PRP (base view – left photo) using parts produced by the NHMFL machine shop and piezo-driven actuators that are a small fraction of the cost of a new unit. It was successfully tested to 77K in July 2017 and will be tested to  $^3\text{He}$  temps and in field with magnet time scheduled for early 2018. The advantage of producing a PRP in-house stems from the ability to make repairs and modifications in a rapid fashion.

In addition a new voltage source to drive the actuators has been constructed by the NHMFL electronics shop which offers a peak output of 200V. This is an improvement over the 70V maximum of our commercial source which we have determined can be a limiting factor in rotation at low temperatures.

An additional challenge with the PRP comes from attempts to calibrate the orientation at high fields ( $B > 10\text{T}$ ). Small, Toshiba THS118 Hall sensors are convenient for measuring the position at low fields but cannot be measured at base temperature ( $\sim 300\text{ mK}$ ) and maximum field (18T) in SCM2. A metallic ring was machined (**Figure 8 c**) and fixed outside of an insulating spacer to the circumference of the PRP. A second electrode is located near this ring to allow for capacitance measurements as the PRP is rotated. This assembly will be tested in high fields with upcoming magnet time in SCM2.

### Results and Conclusion

The new PRP produced in house as well as the voltage source should allow for measurements in two axes. If this version is successful a miniature prototype will be built to fit into the smaller available sample space of the resistive magnets for higher fields.

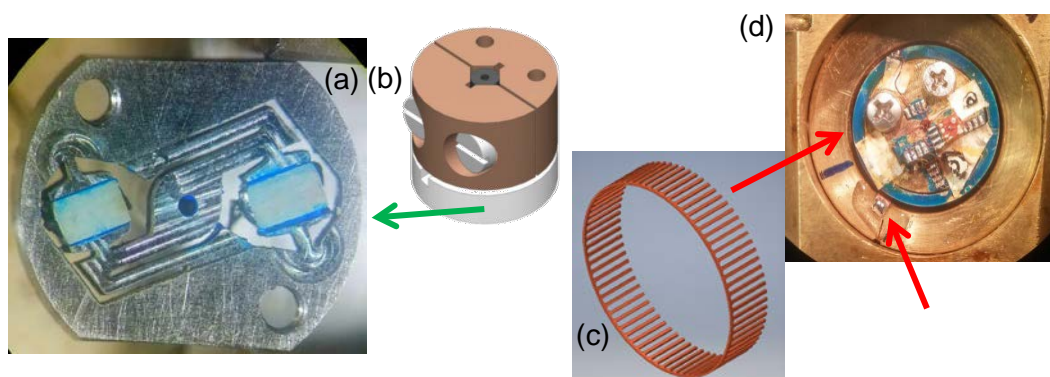

**Figure 8.** (a) Bottom view photo of PRP with cartoon of overall assembly shown in (b). Two pieces of PZT are held in place with Stycast 2850 to the titanium base machined by EDM at the NHMFL. (c) Drawing of capacitance electrode machined as a “comb” and then fixed to the outside of the PRP on top of a thin insulating layer of G10. A second electrode (red arrow in [d]) completes the capacitor and allows for measurements of capacitance as the PRP is rotated.

### Acknowledgements

This work was performed at the NHMFL, which is supported by NSF Cooperative Agreement No. DMR-1157490 and the State of Florida. Additional support was provided through the NHMFL UCGP.

### References

[1] Palm, E.C., *et al.*, Rev. Sci. Instr., **70**, 237 (1999).



# Chapter 5 – In-house Research

CMS

CMS

## 5.2.7. Optical Monitoring Setup for Room-Temperature-Bore Magnets

*Suslov A.V. (NHMFL, FSU)*

### Introduction

Some experiments performed at the NHMFL DC Field Facility resistive magnets require to monitor and detect by optical means the processes occurring inside the magnet bore. For example, the group of Prof. Molodov from Germany brought their homemade setup from overseas to record movements of bi-crystal boundaries in high magnetic fields. The setup was compatible only with a 200-mm bore magnet which was recently decommissioned. Their camera installed in proximity of (above) the magnet would be significantly affected by the magnet fringe field if mounted at stronger magnets. Thus, an improved and more universal optical system was desired.

### Experimental, Results and Discussion

An optical setup was designed and built with a Nikon camera installed far from a magnet and a periscope mounted on the magnet top and used for observing the space inside the magnet bore, see **Figure 9** (a) and (b). Such design is compatible with any resistive magnet. I performed initial testing of the setup using the superconducting outsert of the 45 T hybrid at the NHMFL DC Field Facility. The outsert creates the largest fringe field at the MagLab and the test allowed specifying the distance between the magnet and the camera required for avoidance the fringe field effect on the camera electronics. Also a test performed with the hybrid outsert was power- and cost-efficient compared to the experiments using resistive magnets. An image presented in **Figure 9** (c) demonstrates the system effectiveness as 1/16" balls are photographed from a distance of about 32'.

### Conclusions

An optical setup for observation the space inside the magnet bore was designed, developed, and tested.

### Acknowledgements

The National High Magnetic Field Laboratory is supported by National Science Foundation Cooperative Agreement No. DMR-1157490 and the State of Florida.



(a)

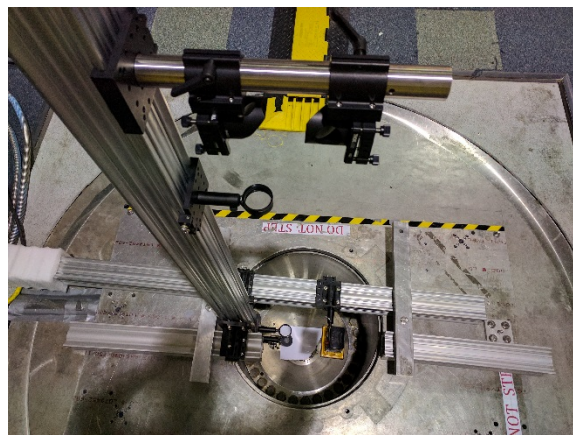

(b)

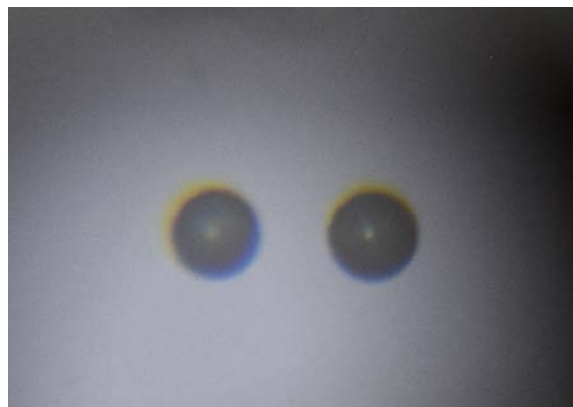

(c)

**Figure 9** (a) A camera, a laser level (at the foreground) and a periscope (at the background) mounted at the hybrid platform. (b) The periscope and other parts of the optical setup mounted near the hybrid. (c) An image obtained by the setup described in text: two 1/16" balls located in the hybrid bore at ~11.5 T.

# Chapter 5 – In-house Research

CMS

## 5.2.8. FTIR magneto-spectroscopy in the NHMFL DC facility: New developments, tests and optimization of experimental protocols

Ozerov, M. (NHMFL)

### Introduction

There are tens of places in the world where infrared measurements can be carried out with applied magnetic fields, but only three of them allow for magnetic fields up to 35T. Thus the main focus of the proposal is a development of the IR experimental set-up for a 35T Bitter magnet to lead the cutting edge research in the NHMFL DC facility. The specific objectives are threefold: (i) improving S/N of IR spectroscopy experiments at high fields in general; (ii) development of new probes and setups; (iii) establishing new experimental protocols and procedures.

### Experimental

IR measurements were performed using FT-IR spectrometer (Bruker IFS 66v) and 35T Bitter magnet (Cell 8). The optical throughput of the old probe was enhanced by the increasing of the aperture of a diamond window to 0.75 inches. The new design of the evacuated mounting stage was successfully developed for a parabolic mirror with aperture of 3 inches. The optimal grounding circle was found to diminish a parasitic interference from mains.

### Results and Discussion

The S/N ratio for this setup is mainly defined by microphonic, vibrational and 60 Hz electric noises, which affect the bolometer's response and thereby define the sensitivity limits. **Figure 10** shows the spectrum of the electrical noise without IR radiation and its dependence on the magnetic field. The dominant part of the noise is confined in the vicinity of 300 Hz at low fields, whereas it is significantly increased and spread to the low frequency range at higher fields. This makes a great challenge for the high-field IR measurements, because bandwidth of the IR bolometer is about 200 Hz. The broad peaks appeared to be

CMS

caused by vibrations of the magnet power cables touching the user platform, whereas the narrow peaks at 30 Hz are microphonic resonance modes of the bolometer unit.

### Conclusions

We investigated the origin of the electrical noise of the IR set-up with the application of high magnetic fields up to 35 T. We found that unavoidable vibrations of the magnet cooling system are mainly transferred to the experimental platform via acoustics channel. To reduce their influence, constructional changes of the user platform are suggested for the cell 8.

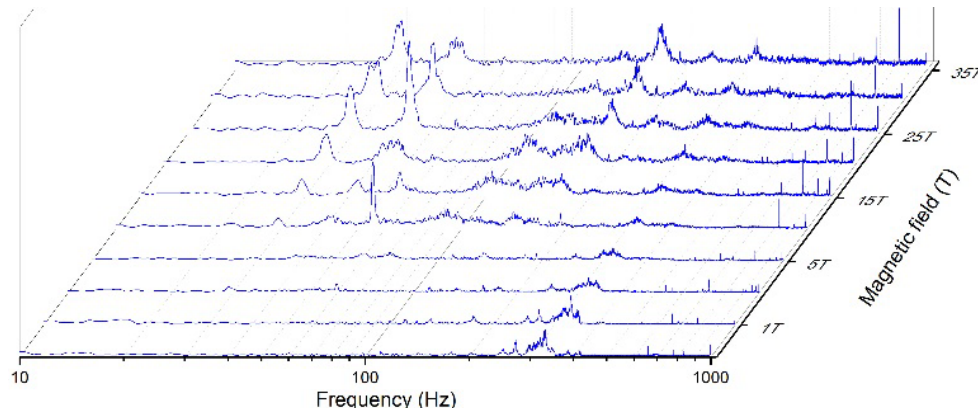

**Figure 10** Spectra of the dark noise measured by the IR probe for several magnetic fields.

### Acknowledgements

A portion of this work was performed at the National High Magnetic Field Laboratory, which is supported by National Science Foundation Cooperative Agreement No. DMR-1157490 and the State of Florida.

# Chapter 5 – In-house Research

CMS

CMS

## 5.2.9. Emergent Bloch excitations in Mott matter

Lanatà N. (FSU, NHMFL & Physics); Lee T.H. (FSU, NHMFL & Physics); Yao Y.X. (Ames Laboratory, ISU) and Dobrosavljević V. (FSU, NHMFL & Physics)

### Abstract

We developed [1] a unified theoretical picture for excitations in Mott systems, portraying both the heavy quasiparticle excitations and the Hubbard bands as features of an emergent Fermi liquid state formed in an extended Hilbert space, which is nonperturbatively connected to the physical system. This observation sheds light on the fact that even the incoherent excitations in strongly correlated matter often display a well-defined Bloch character, with pronounced momentum dispersion. Furthermore, it indicates that the Mott point can be viewed as a topological transition, where the number of distinct dispersing bands displays a sudden change at the critical point. Our results, obtained from an appropriate variational principle [1-3], display also remarkable quantitative accuracy. This opens an exciting avenue for fast realistic modeling of strongly correlated materials.

### Acknowledgements

N.L., T.-H.L. and V.D. were partially supported by the NSF grant DMR-1410132 and the National High Magnetic Field Laboratory. Y.Y. was supported by the U.S. Department of energy, Office of Science, Basic Energy Sciences, as a part of the Computational Materials Science Program.

### References

- [1] Lanatà, N., *et al.*, Phys. Rev. B **96**, 195126 (2017).
- [2] M. C. Gutzwiller, Phys. Rev. **137**, A1726 (1965).
- [3] Lanatà, N., *et al.*, Phys. Rev. X **5**, 011008 (2015).
- [4] Lanatà, N., *et al.*, Phys. Rev. Lett. **118**, 126401 (2017).

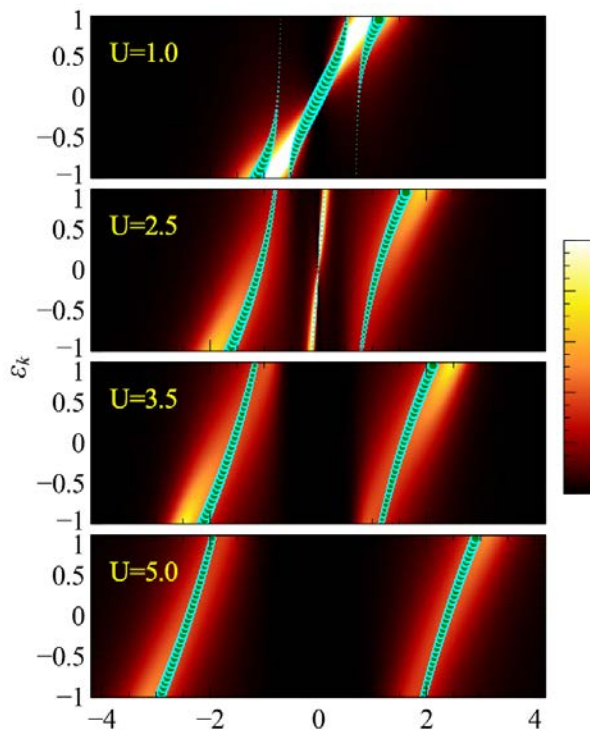

**Figure 11:** Poles of the ghost-GA energy-resolved Green's function (bullets) in comparison with DMFT+NRG. The size of the bullets indicates the spectral weights of the corresponding poles. Metallic solution for  $U = 1, 2.5$  and Mott solution for  $U = 3.5, 5$ .

# Chapter 5 – In-house Research

CRYO

CRYO

## 5.3. Cryogenics Research Group

The Cryogenics Laboratory located at the National High Magnetic Field Laboratory is a fully developed facility for conducting low temperature experimental research and development. A number of specialized experimental equipment are available in the lab, which include the Cryogenic Helium Experimental Facility (CHEF) for horizontal single and two-phase heat transfer and flow research, the Liquid Helium Flow Visualization Facility (LHFVF) for high Reynolds number superfluid helium (He II) flow visualization research, the Laser Induced Fluorescence Imaging Facility (LIFIF) for high precision molecular tagging velocimetry measurement in both gaseous and liquid helium, and the Cryogenic Magnetic Levitation Facility (CMLF) for studying cryogenic fluid hydrodynamics in micro-

gravity. The laboratory supports in-house development projects as well as contracted scientific work directed by two faculty members, Prof. Guo and emeritus Prof. Dr. Van Sciver, of the Mechanical Engineering department at Florida State University.

The major research focus of the cryogenics lab currently includes: 1) fundamental turbulence and heat transfer research in superfluid helium-4 (He II); 2) quantized vortex-line imaging in levitated helium drops; 3) catastrophic loss of vacuum in liquid helium cooled pipes; 4) multilayer insulation (MLI) material thermal property characterization. These research activities are supported by external funding agencies including the National Science Foundation (NSF), the Department of Energy (DoE), the National Aeronautics and Space Administration (NASA), and our industrial partners.

### Turbulence research with He II

Many flows in nature have extremely high Reynolds (Re) or Rayleigh (Ra) numbers, such as those generated by flying aircraft and atmospheric convection. Better understanding of these flows can have profound positive impacts on everyday life, such as improving the design in energy efficient applications and our understanding of climate change. To achieve large Re values in laboratory, a common route is to increase the characteristic length of the flow, which normally requires the construction of expensive and energy consuming large-scale flow facilities and wind tunnels. An alternative method is to use a fluid material with very small kinematic viscosity. At the cryogenics lab, we adopt helium-4 as the working fluid. Helium-4 has extremely small kinematic viscosity (3 orders of magnitudes smaller than that for air) which enables the generation of highly turbulent flows in compact table-top equipment. Furthermore, when helium-4 is cooled below about 2.17 K, it undergoes a phase transition into a superfluid phase (He II) which consists of two miscible fluid components: a viscous normal component and an inviscid superfluid fluid component. Turbulence in He II is a cutting-edge research area that is important both in fundamental science and in practical applications of He II as a coolant. In order to make quantitative flow field measurements, we have developed two powerful flow visualization techniques. One is the so-called

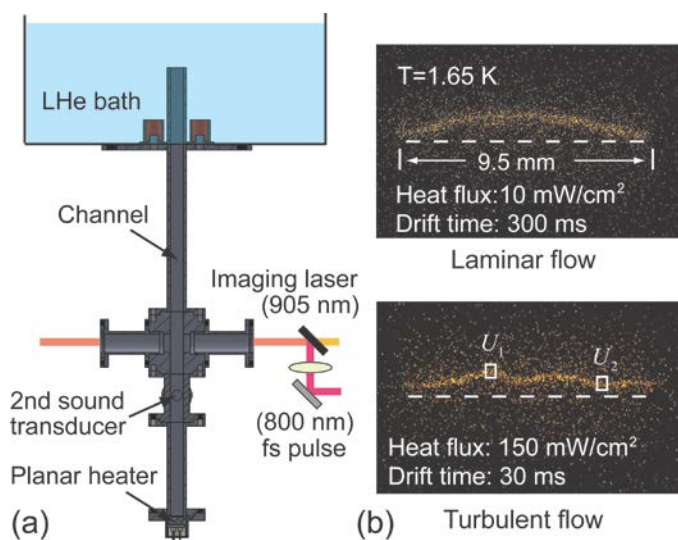

**Figure 1:** (a) Schematic diagram of the experimental setup for flow visualization using He II molecules. A high intensity femto-second laser (red beam) through the windows ionizes helium atoms and creates a tracer line of He II excimer molecules. Then the imaging laser at 905 nm (yellow beam) drives the tracers to produce fluorescent light (640 nm) for the imaging. (b) Typical images of the tracer line in thermal counterflow generated by an applied heat flux in He II. The deformation of the tracer lines provides quantitative information about the velocity field in He II.

# Chapter 5 – In-house Research

CRYO

CRYO

molecular-line tagging velocimetry technique which is developed based on tracking thin lines of He<sub>2</sub> excimer tracers created via femtosecond-laser field ionization of helium atoms (see **Figure 1**). Besides this technique, a particle tracking velocimetry method in He II using seeded micron-sized frozen hydrogen particles has also been developed and implemented. The application of these techniques to the study of heat induced flows in He II has revealed a novel form of turbulence (counterflow turbulence). A systematic characterization of this turbulence will be indispensable for developing a theoretical understanding that will potentially benefit the design of He II based cooling systems. This year, we have also designed and fabricated a new towed-grid system for studying turbulence in He II generated via mechanical forcing. This system will allow us to conduct interesting high Re flow research utilizing the unique properties of helium.

## Vortex imaging in levitated helium drops

The motion of quantized vortex lines is responsible for a wide range of phenomena, such as the decay of quantum turbulence and the initiation of dissipation in type-II superconductors, and it is also implicated in the appearance of glitches in neutron star rotation and the formation of cosmic strings in the early universe. A systematic study of vortex-line dynamics promises broad significance spanning multiple physical science disciplines. In He II, vortex lines can be directly visualized by imaging tracer particles trapped on the lines. However, producing tracers in helium at low

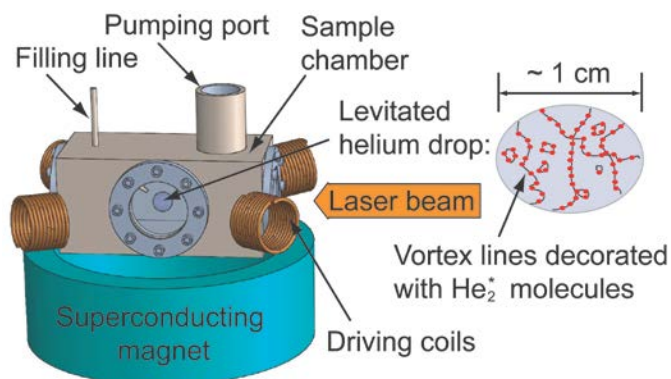

**Figure 2:** Schematic of the experimental apparatus inside the optical cryostat for visualizing quantized vortex lines in a magnetically levitated helium drop.

temperatures and imaging the trapped tracers remains challenging, and the container walls can often affect the vortex-line motion. In the cryogenics lab, a special cryostat with a superconducting magnet in it has been restored and tested recently. The magnet, when it is charged, can levitate a large drop of liquid helium. We plan to create quantized vortices in the drop via fast evaporative cooling of the drop and controlled drop rotation (see **Figure 2**). These vortices will be decorated with He<sub>2</sub> excimer tracers or fluorescence nano-particles which can be imaged via laser-driven fluorescence. This process can enable unprecedented insight into the behavior of a rotating superfluid drop and will untangle some key issues in quantum turbulence research.

## Loss-of-vacuum heat and mass transfer

High performance superconducting magnets and superconducting radio frequency (SRF) cavities are essential components of almost all future high energy particle accelerators. These magnets and SRF cavities are normally cooled by liquid helium. The study of the heat and mass transfer processes that can occur during a sudden catastrophic loss of vacuum (SCLV) incident in a liquid-helium cooled system is therefore of great importance to the design and safe operation of the superconducting magnets and SRF cavities. A project has been launched in the cryogenics lab to study how a gas such as atmospheric air/nitrogen will condense inside a liquid-helium cooled vacuum tube while the gas simultaneously propagates down the vacuum tube. In the past year, we have implemented a new experimental rig that incorporates a vacuum tube of helical geometry designed for He II immersion experiments (see **Figure 3**). Systematic study on the propagation of condensable gas (air or nitrogen) in this tube cooled by liquid helium at 4.2 K has been conducted. The variations of the temperatures at different locations along the tube following the vacuum break were measured at controlled inlet gas pressure. We have observed exponential deceleration of the gas front velocity as the gas propagates along the vacuum tube. More recently, a theoretical model has been developed which explains the deceleration as a consequence of the gas condensation on the inner wall of the tube. Preliminary numerical simulation based on this model can indeed reproduce the observed slowing down of gas

# Chapter 5 – In-house Research

CRYO

CRYO

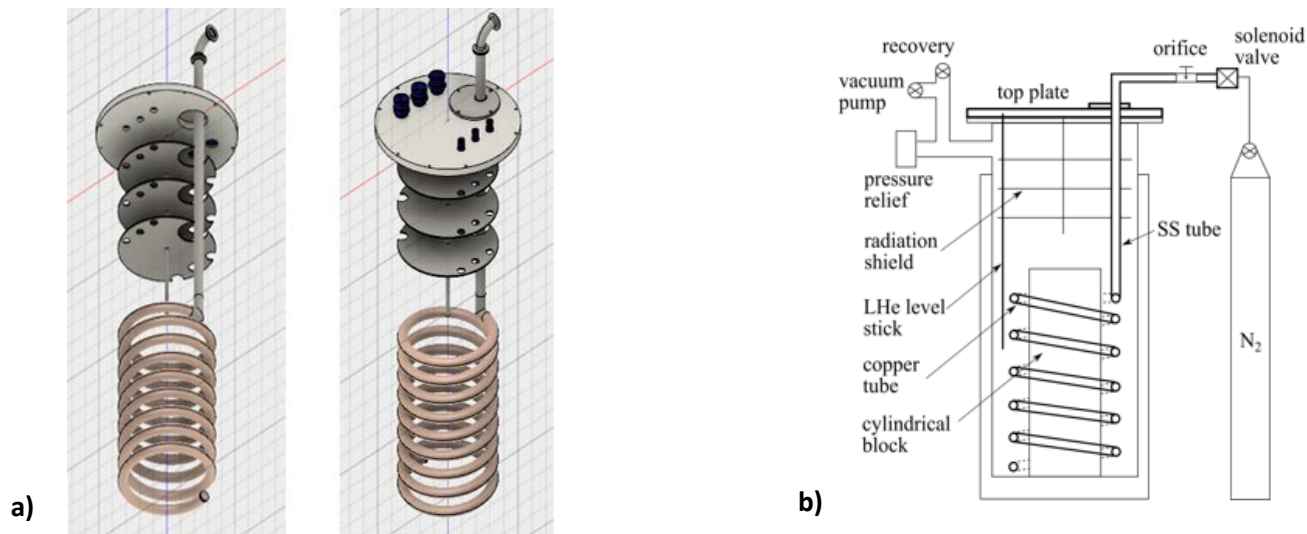
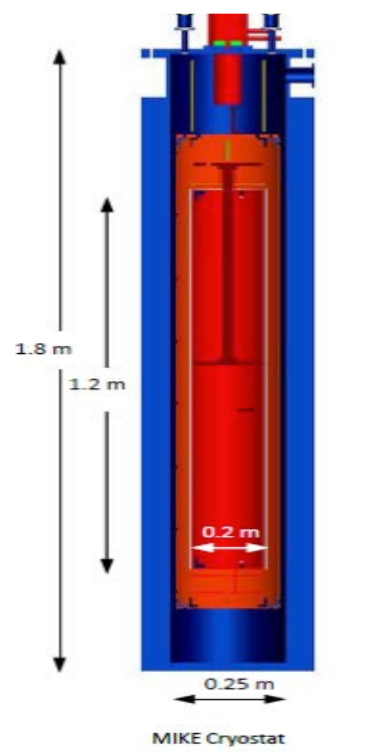

**Figure 3:** (a) Schematic of the helix tube and the top flange of the cryostat. (b) Schematic diagram of the vacuum break experiment in He II.

along the tube. A more systematic comparison of the experimental data and the simulation in the future will allow us to extract valuable information such as the sticking coefficient of the gas molecules on the cold wall.

## Multi-layer insulation thermal conductivity experiment (MIKE)

The Multi-layer Insulation Thermal Conductivity Experiment measures the thermal performance of multi-layer insulation (MLI) materials. This lightweight insulation is composed of alternating thin reflective layers with insulating layers and is used as high performance insulation for spacecraft, cryogen storage tanks, MRI's, and space-borne instruments. A special facility for measuring MLI effective thermal conductivity has been assembled (see **Figure 4**). This facility consists of two concentric copper cylinders which are temperature controlled by cryocoolers and heaters. The MLI is attached in-between the cylinders by taping each layer to itself. The heat from the warm cylinder flows through the MLI to the cold cylinder and then through a calibrated rod to determine the heat load. The cylinder



**Figure 4:** Schematic of the facility built for MIKE research.

# Chapter 5 – In-house Research

## CRYO

measures 191 mm in diameter and 1232 mm long. The warm cylinder measures 272 mm in diameter and 1524 mm long. This facility has allowed us to conduct systematic characterization of the thermal properties of MLI materials. This capability has attracted funds from funding agency such as NASA as well as space industrial partners.

On the education side, our research projects have allowed us to support both undergraduate and graduate students. We have also been able to engage postdoctoral researchers, interns, visiting students, and scholars. These students have obtained training and experiences in fluid dynamics, cryogenics, advanced laser technologies, electronics, and data analysis techniques. These skills are applicable to nearly all STEM related fields, giving these students the technical dexterity necessary to excel in today's science and technology dominated market. All the students supported by our project have also had the opportunity to develop teamwork and communication skills by working closely with facilities engineers, mechanics, electricians, machinists, safety engineers, and welders

## CRYO

throughout the construction of the experimental facility. Our cryogenics lab is also involved in various outreach activities, such as presenting science demonstrations for the annual open house event at the NHMFL. On April 10-12, 2017, the cryogenics lab successfully organized a three-day international workshop on quantum turbulence, sponsored by the NHMFL, FSU, and the NSF. Over 50 guests from 9 countries attended this workshop. More details can be found at the following webpage: <https://nationalmaglab.org/news-events/events/for-scientists/quantum-turbulence-workshop>

This event provided young researchers the opportunity to interact with eminent scientists in the quantum fluid field and effectively promoted FSU's profile in this field. Through this event, our cryogenics group has established collaborations with a number of international partners, such as Prof. Tsubota's group at Osaka City University. A news report can be found at the website:

<https://www.eng.famu.fsu.edu/me/shared/news/article.html?s=quantum-turbulence-workshop>

# Chapter 5 – In-house Research

GEOCHEM

GEOCHEM

## 5.4. Geochemistry

*The facility primarily investigates natural processes, both recent and ancient, through the analysis of trace element contents and isotopic compositions.*

### Introduction

The Geochemistry Program funding is through grants from the Geoscience directorate at NSF, NASA and the USGS. All tenure-track faculty have their appointments in FSU's College of Arts and Sciences. The facility has seven mass spectrometers, which are available to outside users. Three instruments are single collector inductively coupled plasma mass spectrometers for elemental analysis. Of these, one is dedicated to in-situ trace element analyses on solid materials using laser ablation, the other two are dedicated to elemental analyses of solutions. The facility has four mass spectrometers dedicated to determination of isotopic compositions. One is a multi-collector inductively coupled plasma mass spectrometer (NEPTUNE) used for determination of isotopic abundances of metals. A second is a thermal ionization multi collector mass spectrometer, which is mainly used for Sr-isotopic compositions. The third mass spectrometer is designed for the measurement of the light stable isotope compositions (C, N O). A fourth mass spectrometer dedicated to sulfur isotope analyses has been installed in 2017.

### Publications and Outreach

The group members have published 18 peer reviewed publications and a similar number of presentations at meetings and invited presentations at other institutions. The group involves a large number of undergraduate students in their research.

### Science Highlights

The rate at which long-term climate changes occur is an area of intense study. Two research projects obtained significant new findings with respect to climate change. The first concerns thallium (Tl) in the oceans which is strongly influenced by the amount of manganese oxides that precipitate as Tl is scavenged by the Mn-oxide which has a preference for the heavier isotopes. Thus decreasing Mn-oxide formation resulting from a lack of available oxygen (anoxic conditions) will

lead to heavier Tl in seawater. Owens and colleagues compared the Tl-isotope record across the global Oceanic Anoxic Event (OAE) -2 which was about 600kyrs in duration approximately 94 Ma ago. OAEs result in large changes in the carbon cycle and is recorded by the C-isotopes. They found the onset of a Tl-isotope excursion, consistent with diminished Mn-oxide precipitation, that predates the onset of the C-isotope excursion by 43 kyrs. The modern ocean is experiencing increasing deoxygenation. This study, published in *Science Advances*, shows that Tl-isotopes can be an important tool in assessing the global ocean oxidation state.

A second study investigates the change in weathering rates as a response to the large outpour of CO<sub>2</sub> related to the formation of the Karoo-Ferrar Large Igneous Province. This study produced a similar osmium isotope record in black shales during this event as previous studies but from a different ocean basin. It implies that the excursion recorded a global change in seawater related to continental runoff. The excursion is best modeled by an up to 5 times increased weathering rate for several 100kyrs. Enhanced continental weathering would have drawn down atmospheric CO<sub>2</sub> and led to the burial of massive amounts of organic carbon, which eventually cooled the planet and helped to end this OAE. This work is published in *Nature Scientific Reports*.

A third highlight is a study that affects the early stages of our solar system and evidence in iron meteorites for the rapid formation (1-2 Ma) of differentiated bodies. Critical in this research is our ability to correct <sup>182</sup>Hf-<sup>182</sup>W model ages for neutron capture. This research improved the precision of the measurement of Re-isotope ratios where excess <sup>187</sup>Re is produced by the decay of <sup>187</sup>W which is formed by neutron capture of <sup>186</sup>W. The <sup>187</sup>Re/<sup>185</sup>Re can now be used to better correct the W-isotope ratios for neutron capture correction. This work was presented at the Annual meeting of the Meteoritical Society and is the basis of a new NASA grant to Munir Humayun.



# Chapter 5 – In-house Research

GEOCHEM

GEOCHEM

## Progress on Stem and Building the User Community

The facility is open to users of all disciplines, and we have a long-time collaboration with the USGS and the South Florida Water Management District. During the summer we hosted one undergraduate student from the REU program; seventeen undergraduate students are involved in research throughout the year. In the last year, 60 users, of which

52% are female, used our analytical facilities. Graduate student users are 65% female. Within the area of Geosciences the faculty has collaborations with researchers throughout the US, Europe, and Asia. The disciplines for which we do service analyses at a more local level range from magnet science to pharmacy. We also receive several requests per year from the public to identify rock samples that are found, often with the expectation that the sample is a meteorite.



# Chapter 6 – Accomplishments & Discoveries



# Chapter 6 – Accomplishments & Discoveries

## 6. Products of MagLab Users and Faculty

The Laboratory continued its strong record of publishing, with **408** articles appearing in peer-reviewed scientific and engineering journals in 2017, among these, 290 acknowledge NSF support for the operation of the NHMFL. The full listing, along with citations for over **274** presentations, is available on the MagLab's web site <https://nationalmaglab.org/research/publications-all/publications-search>.

This chapter lists publications by user facility, followed by publications attributed to Magnet Science & Technology, the NHMFL Applied Superconductivity Center, UF Physics, the Condensed Matter Theory/Experiment group, the Center for Integrating Research & Learning, Geochemistry, and Optical Microscopy. Please note that publications may be listed with more than one facility or group, as the research may have resulted from the use of multiple facilities, e.g., us-

ing both DC and Pulsed Field Facilities, or from a collaboration that involves both users/ experimentalists and theorists.

Of the **408** publications, **224 (55%)** appeared in significant journals. Presented on the remaining pages of this chapter are lists of one-time publications, internet disseminations, patents, awards, PhD dissertations, and Masters theses.

**Table 1:** Submitted peer-reviewed publications from OPMS live database. The point-in-time snapshot was on February 12, 2018. A total number of publications per year should NOT be drawn from this report because a submitter may, as appropriate, link a publication to two or more facilities. We note that the State of Florida contributes significantly to NHMFL and hired faculty at UF and FSU to enhance NHMFL programs. Publications from these professors are included as they significantly enhance the NHMFL research effort and are listed here in the UF physics and CMT/E categories.

Facility	2017 Peer Reviewed	Acknowledges Core Grant	2017 Significant Peer Reviewed	Acknowledges Core Grant
AMRIS Facility at UF	34	16	9	3
DC Field Facility at FSU	88	82	65	61
EMR Facility at FSU	37	34	20	20
High B/T Facility at UF	7	4	3	2
ICR Facility at FSU	34	29	24	20
NMR Facility at FSU	49	38	26	22
Pulsed Field Facility at LANL	41	32	25	20
Applied Superconductivity Center	24	18	17	13
Magnet Science & Technology Education (NHMFL at FSU only)	28	23	10	8
CMT/E	56	41	42	31
Geochemistry Facility	15	5	1	0
MBI at UF	30	7	2	0
UF Physics	21	9	12	4

# Chapter 6 – Accomplishments & Discoveries

## 6.1. AMRIS Facility at UF

Cites NSF Core Grant	Authors	Title	Journal Name	Vol	Issue	Pages	DOI
X	Aydemir, T.; Kim, M.-H.; Kim, J.; Colon-Perez, L.; Banan, G.; Mareci, T. .H.; Febo, M.; and Cousins, J.R.,	<i>Metal transporter ZIP14 (SLC39A14) deletion in mice increases manganese deposition and produces neurotoxic signatures and diminished motor activity.</i>	<b>Journal of Neuroscience</b>	37	25	5996-6006	10.1523/JNEUROSCI.0285-17.2017
X	Baligand, C.; Todd, A.G.; Lee-McMullen, B.; Vohra, R.S.; Byrne, B.J.; Falk, D.J. and Walter, G.A.,	<i><sup>13</sup>C/<sup>31</sup>P MRS Metabolic Biomarkers of Disease Progression and Response to AAV Delivery of hGAA in a Mouse Model of Pompe Disease</i>	<b>Molecular Therapy- Methods &amp; Clinical Development</b>	15	7	42-49	10.1016/j.mtm.2017.09.002
X	Chrzanowski, S.M.; Vohra, R.S.; Lee-McMullen, B.A.; Batra, A.; Spradlin, R.A.; Morales, J., Forbes, S., Vandenborne, K., Barton, E.R. and Walter, G.A.,	<i>Contrast-Enhanced Near-Infrared Optical Imaging Detects Exacerbation and Amelioration of Murine Muscular Dystrophy</i>	<b>Molecular Imaging</b>	16	-	1.53601E+15	10.1177/1536012117732439
X	DeSimone, J.C.; Pappas, S.S.; Febo, M.; Burciu, R.G.; Shukla, P.; Colon-Perez, L.M.; Dauer, W.T. and Vail-lancourt, D.E.,	<i>Forebrain knock-out of torsinA reduces striatal free-water and impairs whole-brain functional connectivity in a symptomatic mouse model of DYT1 dystonia</i>	<b>Neurobiology of Disease</b>	106	-	124-132	10.1016/j.nbd.2017.06.015
X	Dutta, A.R.; Sekar, P.; Dvoyashkin, M.; Bowers, C.; Ziegler, K.J. and Vasenkov, S.,	<i>Possible role of molecular clustering in single-file diffusion of mixed and pure gases in dipeptide nanochannels</i>	<b>Microporous and Mesoporous Media</b>	early view	-	1-5	10.1016/j.micromeso.2017.05.025
X	Flint, J.J.; Menon, K.; Hansen, B.; Forder, J. and Blackband, S.J.,	<i>Metabolic Support of Excised, Living Brain Tissues During Magnetic Resonance Microscopy Acquisition</i>	<b>Journal of visualized experiments: JoVE</b>	128	-	e56282	10.3791/56282
X	Forman, E.M.; Pimentel, B.R.; Ziegler, K.J.; Lively, R.P. and Vasenkov, S.,	<i>Microscopic diffusion of pure and mixed methane and carbon dioxide in ZIF-11 by high field diffusion NMR</i>	<b>Microporous and Mesoporous Materials</b>	248	-	158-163	10.1016/j.micromeso.2017.04.041
X	Hawkins, K.E.; DeMars, K.M.; Alexander, J.C.; Leon, L.G.; Pacheco, S.C.; Graves, C.; Yang, C.; McCrea, A.O.; Frankowski, J.C.; Garrett, T.J. and Febo, M.,	<i>Targeting resolution of neuroinflammation after ischemic stroke with a lipoxin A(4) analog: Protective mechanisms and long-term effects on neurological recovery</i>	<b>Brain and Behavior</b>	7	5	e00688	10.1002/brb3.688
X	Lee, C.H.; Bengtsson, N.; Chrzanowski, S.M.; Flint, J.J.; Walter, G.A. and Blackband, S.J.,	<i>Magnetic Resonance Microscopy (MRM) of Single Mammalian Myofibers and Myonuclei</i>	<b>Scientific Reports</b>	7	-	39496	10.1038/sr39496
X	Ragavan, M.; Kirpich, A.; Fu, X.; Burgess, S.C.; McIntyre, L.M. and Merritt, M.E.,	<i>A comprehensive analysis of myocardial substrate preference emphasizes the need for a synchronized fluxomic/metabolomic research design</i>	<b>American Journal of Physiology-Heart and Circulatory Physiology</b>	312	6	H1215-H1223	10.1152/ajpheart.00016.2017
X	Thapa, B.; Diaz-Diestra, D.; Beltran-Huarac, J.; Weiner, B.R. and Morell, G.,	<i>Enhanced MRI T<sub>2</sub> Relaxivity in Contrast-Probed Anchor-Free PEGylated Iron Oxide Nanoparticles</i>	<b>Nanoscale Research Letters</b>	12	1	312	10.1186/s11671-017-2084-y
X	Tran, N.; Kurian, J.; Bhatt, A.; McKenna, R. and Long, J.R.,	<i>Entropic Anomaly Observed in Lipid Polymorphisms Induced by Surfactant Peptide SP-B(1-25)</i>	<b>Journal of Physical Chemistry B</b>	121	39	9102-9112	10.1021/acs.jpcc.7b06538

# Chapter 6 – Accomplishments & Discoveries

Cites NSF Core Grant	Authors	Title	Journal Name	Vol	Issue	Pages	DOI
X	Vohra, R.; Batra, A.; Forbes, S.C.; Vandendorpe, K. and Walter, G.A.,	<i>Magnetic Resonance Monitoring of Disease Progression in mdx Mice on Different Genetic Background</i>	<b>Journal of American Pathology</b>	187	9	2060-2070	10.1016/j.jpath.2017.05.010
X	Xu, J.; Mueller, R.; Hazelbaker, E.D.; Zhao, Y.; Bonzongo, J.C.J.; Clar, J.G.; Vasenkov, S. and Ziegler, K.J.,	<i>Strongly Bound Sodium Dodecyl Sulfate Surrounding Single-Wall Carbon Nanotubes</i>	<b>Langmuir</b>	33	20	5006-5014	10.1021/acs.langmuir.7b00758
X	Xu, S.; Silveira, M.L.; Ngatia, L.W.; Normand, A.E.; Sollenberger, L.E. and Reddy, K.R.,	<i>Carbon and nitrogen pools in aggregate size fractions as affected by sieving method and land use intensification</i>	<b>Geoderma</b>	305	-	70-79	10.1016/j.geoderma.2017.05.044
X	Zubcevic, J.; Santisteban, M.M.; Perez, P.D.; Arocha, R.; Hiller, H.; Malphurs, W.L.; Colon-Perez, L.M.; Sharma, R.K.; De Kloet, A.; Krause, E.G. and Febo, M.,	<i>A Single Angiotensin II Hypertensive Stimulus Is Associated with Prolonged Neuronal and Immune System Activation in Wistar-Kyoto Rats</i>	<b>Frontiers in Physiology</b>	8	-	529	10.3389/fphys.2017.00592
	Al-Awadhi, F.H.; Salvador, L.A.; Law, B.K.; Paul, V.J. and Luesch, H.,	<i>Kempopeptin C, a Novel Marine-Derived Serine Protease Inhibitor Targeting Invasive Breast Cancer</i>	<b>Marine Drugs</b>	15	9	290	10.3390/md15090290
	Besingi, R.N.; Wenderska, I.B.; Senadheera, D.B.; Cvitkovitch, D.G.; Long, J.R.; Wen, Z.T. and Brady, L.J.,	<i>Functional amyloids in Streptococcus mutans, their use as targets of biofilm inhibition and initial characterization of SMU_63c</i>	<b>Microbiology-SGM</b>	163	4	488-501	10.1099/mic.0.000443
	Butcher, R.A.,	<i>Small-molecule pheromones and hormones controlling nematode development</i>	<b>Nature Chemical Biology</b>	13	6	577-586	10.1038/nchembio.2356
	Febo, M.; Blum, K.; Badgaiyan, R.D.; Perez, P.D.; Colon-Perez, L.M.; Thanos, P.K.; Ferris, C.F.; Kulkarni, P.; Giordano, J.; Baron, D. and Gold, M.S.,	<i>Enhanced functional connectivity and volume between cognitive and reward centers of naive rodent brain produced by prodopaminergic agent KB220Z</i>	<b>PLoS ONE</b>	12	4	e0174774	10.1371/journal.pone.0174774
	Guo, Y.; Wang, L.; Guo, J.; Gu, G. and Guo, Z.,	<i>Biochemical studies of inositol N-acetylglucosaminyltransferase involved in mycothiol biosynthesis in Corynebacterium diphtheria</i>	<b>Organic &amp; Biomolecular Chemistry</b>	15	17	3775-3782	10.1039/C7OB00555E
	Marco-Rius, I.; Cao, P.; von Morze, C.; Merritt, M.; Moreno, K.X.; Chang, G.Y.; Ohliger, M.A.; Pearce, D.; Kurhanewicz, J.; Larson, P.E. and Vigneron, D.B.,	<i>Multiband Spectral-Spatial RF Excitation for Hyperpolarized [2-C-13]Dihydroxyacetone C-13-MR Metabolism Studies</i>	<b>Magnetic Resonance in Medicine</b>	77	4	1419-1428	10.1002/mrm.26226
	Marco-Rius, I.; von Morze, C.; Sriram, R.; Cao, P.; Chang, G.Y.; Milshteyn, E.; Bok, R.A.; Ohliger, M.A.; Pearce, D.; Kurhanewicz, J.; Larson, P.E.; Vigneron, D.B.; Merritt, M.,	<i>Monitoring acute metabolic changes in the liver and kidneys induced by fructose and glucose using hyperpolarized [2-13C]dihydroxyacetone</i>	<b>Magnetic Resonance in Medicine</b>	77	1	65-73	10.1002/mrm.26525
	Middlebrooks, E.H.; Quisling, R.G.; King, M.A.; Carney, P.R.; Roper, S.; Colon-Perez, L. M. and Mareci, T.H.,	<i>The hippocampus: detailed assessment of normative two-dimensional measurements, signal intensity, and subfield conspicuity on routine 3T T2-weighted se-</i>	<b>Surgical and Radiologic Anatomy</b>	39	10	1149-1159	10.1007/s00276-017-1843-x

# Chapter 6 – Accomplishments & Discoveries

Cites NSF Core Grant	Authors	Title	Journal Name	Vol	Issue	Pages	DOI
		quences.					
	Moreno, K.X.; Harrison, C.E.; Merritt, M.E.; Kovacs, Z.; Malloy, C.R. and Sherry, A.D.,	<i>Hyperpolarized <math>\Delta</math>-[1-C-<sup>13</sup>]gluconolactone as a probe of the pentose phosphate pathway</i>	<b>NMR in Bio- medicine</b>	30	6	e3713	10.1002/nbm.3713
	Normand, A.E.; Smith, A.N.; Clark, M.W.; Long, J.R. and Reddy, K.R.,	<i>Chemical Composition of Soil Organic Matter in a Subarctic Peatland: Influence of Shifting Vegetation Communities</i>	<b>Soil Science Society of America Journal</b>	81	1	41-49	10.2136/sssaj2016.05.0148
	Ramaswamy, V.; Brey, W.W. and Edison, A.S.,	<i>Inductively-Coupled Frequency Tuning and Impedance Matching in HTS-Based NMR Probes</i>	<b>IEEE Transactions on Applied Superconductivity</b>	27	4	1-5	10.1109/TASC.2017.2672718
	Silvers, M.A.; Deja, S.; Singh, N.; Egnatchik, R.A.; Suderth, J.; Luo, X.; Beg, M.S.; Burgess, S.C.; DeBerardinis, R.J.; Boothman, D.A. and Merritt, M.E.,	<i>The NQO1 bioactivatable drug, <math>\beta</math>-Lapachone, alters the redox state of NQO1+ pancreatic cancer cells, causing perturbation in central carbon metabolism</i>	<b>Journal of Biological Chemistry</b>	292	44	18203-18216	10.1074/jbc.M117.813923
	Sirusi, A.A.; Suh, E.H.; Kovacs, Z. and Merritt, M.E.,	<i>The effect of Ho3+ doping on 13C dynamic nuclear polarization at 5 T</i>	<b>Physical Chemistry Chemical Physics</b>	20	-	728-731	10.1039/C7CP07198A
	Sunny, N.E.; Bril, F. and Cusi, K.,	<i>Mitochondrial Adaptation in Non-alcoholic Fatty Liver Disease: Novel Mechanisms and Treatment Strategies</i>	<b>Trends in Endocrinology and Metabolism</b>	28	4	250-260	10.1016/j.tem.2016.11.006
	Torres, I.C.; Turner, B.L. and Reddy, K.R.,	<i>Phosphatase activities in sediments of subtropical lakes with different trophic states</i>	<b>Hydrobiologia</b>	788	1	305-318	10.1007/s10750-016-3009-y
	Yang, C.; DeMars, K.M.; Alexander, J.C.; Febo, M. and Candelario-Jalil, E.,	<i>Sustained Neurological Recovery After Stroke in Aged Rats Treated With a Novel Prostacyclin Analog</i>	<b>Stroke</b>	48	7	0	10.1161/STROKEAHA.117.016474
	Yang, H.; Abouelhassan, Y.; Burch, G.M.; Kallifidas, D.; Huang, G.; Yousaf, H.; Jin, S.; Luesch, H. and Huigens, R.W.,	<i>A Highly Potent Class of Halogenated Phenazine Antibacterial and Biofilm-Eradicating Agents Accessed Through a Modular Wohl-Aue Synthesis</i>	<b>Scientific Reports</b>	7	-	16	10.1038/s41598-017-01045-3
	Zhao, E.W.; Maligal-Ganesh, R.; Xiao, C.; Goh, T.-W.; Qi, Z.; Pei, Y.; Hagelin-Weaver, H. E.; Huang, W. and Bowers, C.R.,	<i>Silica-Encapsulated Pt-Sn Intermetallic Nanoparticles: A Robust Catalytic Platform for Parahydrogen-Induced Polarization of Gases and Liquids</i>	<b>Angewandte Chemie International Edition</b>	56	-	3925-3929	10.1002/anie.201701314

## 6.2. DC Field Facility at FSU

Cites NSF Core Grant	Authors	Title	Journal Name	Vol	Issue	Pages	DOI
<b>X</b>	Abhyankar, N.; Kweon, J.J.; Orio, M.; Bertaina, S.; Lee, M.; Choi, E.S.; Fu, R. and Dalal, N.S.,	<i>Understanding Ferroelectricity in the Pb-Free Perovskite-Like Metal-Organic Framework [(CH<sub>3</sub>)<sub>2</sub>NH<sub>2</sub>]Zn(HCOO)<sub>3</sub>: Dielectric, 2D NMR, and Theoretical Studies</i>	<b>Journal of Physical Chemistry C</b>	121	11	6314-6322	10.1021/acs.jpcc.7b00596

# Chapter 6 – Accomplishments & Discoveries

Cites NSF Core Grant	Authors	Title	Journal Name	Vol	Issue	Pages	DOI
X	Agosta, C.C.; Fortune, N.A.; Hannahs, S.T.; Gu, S.Y.; Liang, L.; Park, J.H. and Schlueter, J.A.,	<i>Calorimetric Measurements of Magnetic-Field-Induced Inhomogeneous Superconductivity Above the Paramagnetic Limit</i>	<b>Physical Review Letters</b>	118	26	267001	10.1103/PhysRevLett.118.267001
X	al-Wahish, A.; O'Neal, K.R.; Lee, C.; Fan, S.; Hughey, K.; Yokosuk, M.O.; Clune, A.J.; Li, Z.; Schlueter, J.A.; Manson, J.L.; Whangbo, M.-H. and Musfeldt, J.L.,	<i>Magnetic quantum phase transitions and magnetoelastic coupling in S=1/2 Heisenberg antiferromagnets</i>	<b>Physical Review B</b>	95	-	104437	10.1103/PhysRevB.95.104437
X	Asaba, T.; Lawson, B.J.; Tinsman, C.; Chen, L.; Corbae, P.; Li, G.; Qiu, Y.; Hor, Y.S.; Fu, L. and Li, L.,	<i>Rotational Symmetry Breaking in a Trigonal Superconductor Nb-doped Bi2Se3</i>	<b>Physical Review X</b>	7	-	11009	10.1103/PhysRevX.7.011009
X	Campbell, D.J.; Eckberg, C.; Wang, K.F.; Wang, L.M.; Hodovanets, H.; Graf, D.; Parker, D. and Paglione, J.,	<i>Quantum oscillations in the anomalous spin density wave state of FeAs</i>	<b>Physical Review B</b>	96	7	75120	10.1103/PhysRevB.96.075120
X	Cary, S.K.; Galley, S.S.; Marsh, M.L.; Hobart, D.; Baumbach, R.E.; Cross, J.N.; Stritzinger, J.T.; Polinski, M.J.; Maron, L. and Albrecht-Schmitt, T.E.,	<i>Incipient class II mixed valency in a plutonium solid-state compound</i>	<b>Nature Chemistry</b>	9	-	856-861	10.1038/nchem.2777
X	Chen, Z.-G.; Wang, L.; Song, Y.; Lu, X.; Luo, H.; Zhang, C.; Dai, P.; Yin, Z.; Haule, K. and Kotliar, G.,	<i>Two-dimensional massless Dirac fermions in antiferromagnetic AFe2As2 (A = Ba, Sr)</i>	<b>Physical Review Letters</b>	119	-	96401	10.1103/PhysRevLett.119.096401
X	Chen, Z.-G.; Chen, R.Y.; Zhong, R.D.; Schneeloch, J.; Zhang, C.; Huang, Y.; Qu, F.; Yu, R.; Li, Q.; Gu, G.D. and Wang, N.L.,	<i>Spectroscopic evidence for bulk-band inversion and three-dimensional massive Dirac fermions in ZrTe5</i>	<b>Proceedings of the National Academy of Sciences of the United States of America</b>	114	-	816-821	10.1073/pnas.1613110114
X	Cyr-Choinière, O.; Badoux, S.; Grissonnanche, G.; Michon, B.; Afshar, S.A.A.; Fortier, S.; LeBoeuf, D.; Graf, D.; Day, J.; Bonn, D.A.; Hardy, W.N.; Liang, R.; Doiron-Leyraud, N. and Taillefer, L.,	<i>Anisotropy of the Seebeck Coefficient in the Cuprate Superconductor YBa2Cu3Oy: Fermi-Surface Reconstruction by Bidirectional Charge Order</i>	<b>Physical Review X</b>	7	-	31042	10.1103/PhysRevX.7.031042
X	Doiron-Leyraud, N.; Cyr-Choinière, O.; Badoux, S.; Ataei, A.; Collignon, C.; Gourgout, A.; Dufour-Beauséjour, S.; Tafti, F.F.; Laliberté, F.; Boulanger, M.-E.; Matusiak, M.; Graf, D.; Kim, M.; Zhou, J.-S.; Momono, N.; Kurosawa, T.; Takagi, H. and Taillefer, L.,	<i>Pseudogap phase of cuprate superconductors confined by Fermi surface topology</i>	<b>Nature Communications</b>	8	-	2044	10.1038/s41467-017-02122-x
X	Drichko, I.L.; Smirnov, I.Y.; Suslov, A.V.; Galperin, Y.M.; Pfeiffer, L.N. and West, K.W.,	<i>Nature of localized states in two-dimensional electron systems in the quantum Hall regime: Acoustic studies</i>	<b>Low Temperature Physics</b>	43	1	86-94	10.1063/1.4975107

# Chapter 6 – Accomplishments & Discoveries

Cites NSF Core Grant	Authors	Title	Journal Name	Vol	Issue	Pages	DOI
X	Du, L.; Li, X.; Lou, W.; Sullivan, G.; Chang, K.; Kono, J. and Du, R.R.,	<i>Evidence for a Topological Excitonic Insulator in InAs/GaSb Bilayers</i>	<b>Nature Communications</b>	8	-	1971	10.1038/s41467-017-01988-1
X	Dun, Z.L.; Trinh, J.; Lee, M.; Choi, E.S.; Li, K.; Hu, Y.F.; Wang, Y.X.; Blanc, N.; Ramirez, A.P. and Zhou, H.D.,	<i>Structural and magnetic properties of two branches of the tripod-kagome-lattice family A<sub>2</sub>R<sub>3</sub>Sb<sub>3</sub>O<sub>14</sub> (A = Mg, Zn; R = Pr, Nd, Gd, Tb, Dy, Ho, Er, Yb)</i>	<b>Physical Review B</b>	95	10	104439	10.1103/PhysRevB.95.104439
X	Gallagher, A., Chen, K.-W.; Cary, S.K.; Kametani, F.; Graf, D.; Albrecht-Schmitt, T.E.; Shekhter, A. and Baumbach, R.E.,	<i>Thermodynamic and electrical transport investigation of URu<sub>2</sub>Si<sub>2-x</sub>P<sub>x</sub></i>	<b>Journal of Physics-Condensed Matter</b>	29	-	24004	10.1088/0953-8984/29/2/024004
X	Gan, Z.; Hung, I.; Wang, X.L.; Paulino, J.; Wu, G.; Litvak, I.M.; Gor'kov, P.L.; Brey, W.W.; Lendi, P.; Schiano, J.L.; Bird, M.D.; Dixon, L.R.; Toth, J.; Boebinger, G.S. and Cross, T.A.,	<i>NMR spectroscopy up to 35.2 T using a series-connected hybrid magnet</i>	<b>Journal of Magnetic Resonance</b>	284	-	125-136	10.1016/j.jmr.2017.08.007
X	Grinenko, V.; Iida, K.; Kurth, F.; Efremov, D.V.; Drechsler, S.-L.; Cherniavskii, I.; Morozov, I.; Hänisch, J.; Förster, T.; Tarantini, C.; Jaroszynski, J.; Maiorov, B.; Jaime, M.; Yamamoto, A.; Nakamura, I.; Fujimoto, R.; Hatano, T.; Ikuta, H. and Hühne, R.,	<i>Selective mass enhancement close to the quantum critical point in BaFe<sub>2</sub>(As<sub>1-x</sub>P<sub>x</sub>)<sub>2</sub></i>	<b>Nature Scientific Reports</b>	7	-	4589	10.1038/s41598-017-04724-3
X	Hatke, A.T.; Liu, Y.; Engel, L.W.; Shayegan, M.; Pfeiffer, L.N.; West, K.W. and Baldwin, K.W.,	<i>Microwave Spectroscopic Observation of Wigner solid within the nu=1/2 fractional quantum Hall effect</i>	<b>Physical Review B</b>	95	-	45417	10.1103/PhysRevB.95.045417
X	He, Q.L.; Pan, L.; Stern, A.L.; Burks, E.C.; Che, X.; Yin, G.; Wang, J.; Lian, B.; Zhou, Q.; Choi, E.S.; Murata, K.; Kou, X.; Chen, Z.; Nie, T.; Shao, Q.; Fan, Y.; Zhang, S.-C.; Liu, K.; Xia, J. and Wang, K.L.,	<i>Chiral Majorana fermion in a quantum anomalous Hall insulator-superconductor structure</i>	<b>Science</b>	357	-	294	10.1126/science.aag2792
X	Holinsworth, B.S.; Sims, H.; Cherian, J.G.; Mazumdar, D.; Harms, N.C.; Chapman, B.C.L.; Gupta, A.; McGill, S.A.; and Musfeldt, J.L.,	<i>Magnetic field tunability of spin-polarized excitations in a high-temperature magnet</i>	<b>Physical Review B</b>	96	-	094427-094431	10.1103/PhysRevB.96.094427
X	Hu, J.; Zhu, Y.L.; Graf, D.; Tang, Z.J.; Liu, J.Y. and Mao, Z.Q.,	<i>Quantum oscillation studies of topological semimetal candidate ZrGeM (M = S, Se, Te)</i>	<b>Physical Review B</b>	95	20	205134	10.1103/PhysRevB.95.205134
X	Hughey, K.D.; Clune, A.J.; Yokosuk, M.O.; al-Wahish, A.; O'Neal, K.R.; Fan, S.; Abhyankar, N.; Xiang, H.; Li, Z.; Singleton, J.; Dalal, N. S. and Musfeldt, J.L.,	<i>Phonon mode links ferroicities in multiferroic [(CH<sub>3</sub>)<sub>2</sub>NH<sub>2</sub>]Mn(HCOO)<sub>3</sub></i>	<b>Physical Review B</b>	96	-	180305(R)	10.1103/PhysRevB.96.180305



# Chapter 6 – Accomplishments & Discoveries

Cites NSF Core Grant	Authors	Title	Journal Name	Vol	Issue	Pages	DOI
X	Iida, K.; Sato, H.; Tarantini, C.; Hänisch, J.; Jaroszynski, J.; Hiramatsu, H.; Holzapfel, B. and Hosono, H.,	<i>High-field transport properties of a P-doped BaFe<sub>2</sub>As<sub>2</sub> film on technical substrate</i>	<b>Nature Scientific Reports</b>	7	-	39951	10.1038/srep39951
X	Jaime, M.; Corvalán Moya, C.; Weickert, F.; Zapf, V.; Balakirev, F.F.; Wartenbe, M.; Rosa, P.F.S.; Betts, J.B.; Rodriguez, G.; Crooker, S.A. and Daou, R.,	<i>Fiber Bragg Grating Dilatometry in Extreme Magnetic Field and Cryogenic Conditions</i>	<b>Sensors</b>	17	11	2572	10.3390/s17112572
X	Jiang, Y.; Dun, Z.L.; Zhou, H.D.; Lu, Z.; Chen, K.-W.; Moon, S.; Besara, T.; Siegrist, T. M.; Baumbach, R. E.; Smirnov, D. and Jiang, Z.,	<i>Landau-level spectroscopy of massive Dirac fermions in single-crystalline ZrTe<sub>5</sub> thin flakes</i>	<b>Physical Review B Rapid Communications</b>	96	-	041101(R)	10.1103/PhysRevB.96.041101
X	Jiang, Y.; Thapa, S.; Sanders, G.D.; Stanton, C.J.; Zhang, Q.; Kono, J.; Lou, W.K.; Chang, K.; Hawkins, S.D.; Klem, J.F.; Pan, W.; Smirnov, D. and Jiang, Z.,	<i>Probing the semiconductor to semimetal transition in InAs/GaSb double quantum wells by magneto-infrared spectroscopy</i>	<b>Physical Review B</b>	95	-	45116	10.1103/PhysRevB.95.045116
X	Kawasaki, S.; Li, Z.; Kitahashi, M.; Lin, C.T.; Kuhns, P.L.; Reyes, A.P. and Zheng, G.-Q.,	<i>Charge-density-wave order takes over antiferromagnetism in Bi<sub>2</sub>Sr<sub>2-x</sub>La<sub>x</sub>CuO<sub>6</sub> superconductors</i>	<b>Nature Communications</b>	8	-	1267	10.1038/s41467-017-01465-9
X	Kuskovsky, I.L.; Mouroukh, L.G.; Roy, B.; Ji, H.; Dhomkar, S.; Ludwig, J.; Smirnov, D. and Tamargo, M.C.,	<i>Decoherence in semiconductor nanostructures with type-II band alignment: All-optical measurements using Aharonov-Bohm excitons</i>	<b>Physical Review B</b>	95	-	165445	10.1103/PhysRevB.95.165445
X	Kweon, J.J.; Fu, R.; Choi, E.S. and Dalal, N.S.,	<i>Magic angle spinning NMR study of the ferroelectric transition of KH<sub>2</sub>PO<sub>4</sub>: definitive evidence of a displacive component</i>	<b>Journal of Physics-Condensed Matter</b>	29	-	16LT01	10.1088/1361-648X/aa638a
X	Lai, Y. ; Saunders, S.M.; Graf, D.; Gallagher, A.; K.-Chen, W.; Kametani, F.; Besara, T.; Siegrist, T.; Shehter, A. and Baumbach, R.E.,	<i>Correlated electron state in CeCu<sub>2</sub>Si<sub>2</sub> controlled through Si to P substitution.</i>	<b>Phys. Rev. Materials</b>	1	-	34801	10.1103/PhysRevMaterials.1.034801
X	Leahy, I.A.; Pocs, C.A.; Siegfried, P.E.; Graf, D.; Do, S.-H.; Choi, K.-Y.; Normand, B. and Lee, M.,	<i>Anomalous Thermal Conductivity and Magnetic Torque Response in the Honeycomb Magnet <math>\alpha</math>-RuCl<sub>3</sub></i>	<b>Physical Review Letters</b>	118	-	187203	10.1103/PhysRevLett.118.187203
X	Lee, J.A.; Xin, Y.; Stolt, I.; Halperin, W.P.; Reyes, A.P.; Kuhns, P.L. and Chan, M.K.,	<i>Coherent Charge and Spin-Density Waves in Underdoped HgBa<sub>2</sub>CuO<sub>4</sub>+<math>\delta</math></i>	<b>New Journal of Physics</b>	19	-	33024	10.1088/1367-2630/aa6277
X	Lee, J.A.; Xin, Y.; Stolt, I.; Halperin, W.P.; Reyes, A.P.; Kuhns, P.L. and Chan, M.K.,	<i>Magnetic-field-induced vortex-lattice transition in HgBa<sub>2</sub>CuO<sub>4</sub>+<math>\delta</math></i>	<b>Physical Review B</b>	95	-	24512	10.1103/PhysRevB.95.024512
X	Lee, M.; Choi, E.S.; Ma, J.; Sinclair, R.; Cruz, C.R.D. and Zhou, H.D.,	<i>Magnetic and electric properties of triangular lattice antiferromagnets Ba<sub>3</sub>ATa<sub>2</sub>O<sub>9</sub> (A = Ni and Co)</i>	<b>Materials Research Bulletin</b>	88	-	308-314	10.1016/j.materresbull.2016.12.039

# Chapter 6 – Accomplishments & Discoveries

Cites NSF Core Grant	Authors	Title	Journal Name	Vol	Issue	Pages	DOI
X	Lee, S.; Lee, W.-J.; van Tol, J.; Kuhns, P.L.; Reyes, A.P.; Berger, H. and Choi, K.-Y.,	<i>Anomalous spin dynamics in the coupled spin tetramer system CuSeO<sub>3</sub></i>	<b>Physical Review B</b>	95	-	54405	10.1103/PhysRevB.95.054405
X	Lee, W.-J.; Do, S.-H.; Yoon, S.; Lee, S.; Choi, Y.S.; Jang, D.J.; Brando, M.; Lee, M.; Choi, E.S.; Ji, S.; Jang, Z.H.; Suh, B.J. and Choi, K.-Y.,	<i>Putative spin liquid in the triangle-based iridate Ba<sub>3</sub>IrTi<sub>2</sub>O<sub>9</sub></i>	<b>Physical Review B</b>	96	-	14432	10.1103/PhysRevB.96.014432
X	Liu, J.Y.; Hu, J.; Graf, D.; Zou, T.; Zhu, M.; Shi Y.; Che, S.; Radmanesh, S.M.A.; Lau, C.N.; Spinu, L.; Cao H.B.; Ke, K. and Mao, Z.Q.,	<i>Unusual interlayer quantum transport caused by the zeroth Landau level in YbMnBi<sub>2</sub></i>	<b>Nature Communications</b>	8	-	646	10.1038/s41467-017-00673-7
X	Liu, J.Y.; Hu, J.; Zhang, Q.; Graf, D.; Cao, H. B.; Radmanesh, S.M.A.; Adams, D.J.; Zhu, Y.L.; Cheng, G.F.; Liu, X.; Phelan, W. A.; Wei, J.; Jaime, M.; Balakirev, F.; Tennant, D.A.; DiTusa, J.F.; Chiorescu, I.; Spinu, L. and Mao, Z.Q.,	<i>A magnetic topological semimetal Sr<sub>1-y</sub>Mn<sub>1-z</sub>Sb<sub>2</sub> (y, z &lt; 0.10)</i>	<b>Nature Materials</b>	16	9	905-910	10.1038/nmat4953
X	Lu, L.; Song, M.; Liu, W.; Reyes, A.P.; Kuhns, P.; Lee, H.O.; Fisher, I.R. and Mitrović, V.F.,	<i>Magnetism and local symmetry breaking in a Mott insulator with strong spin orbit interactions</i>	<b>Nature Communications</b>	8	-	14407	10.1038/ncomms14407
X	Lu, T.M.; Harris, C.T.; Huang, S.-H.; Chuang, Y.; Li, J.-Y. and Liu, C.W.,	<i>Effective g factor of low-density two-dimensional holes in a Ge quantum well</i>	<b>Applied Physics Letters</b>	111	-	102108	10.1063/1.4990569
X	Lu, T.M.; Tracy, L.A.; Laroche, D.; Huang, S.-H.; Yen, C.; Su, Y.-H.; Li, J.-Y. and Liu, C.W.,	<i>Density-controlled quantum Hall ferromagnetic transition in a two-dimensional hole system</i>	<b>Nature Scientific Reports</b>	7	-	2468	10.1038/s41598-017-02757-2
X	Ma, Meng K.; Hossain, Md. Shafayat; Villegas Rosales, K. A.; Deng, H.; Tschirky, T.; Wegscheider, W. and Shayegan, M.,	<i>Observation of Fractional Quantum Hall Effect in an InAs Quantum Well</i>	<b>Physical Review B Rapid Communications</b>	96	-	241301	10.1103/PhysRevB.96.241301
X	Machado, F.L.A.; Soares, J.M.; Conceição, O.L.A.; Choi, E.S. and Balicas, L.,	<i>Magnetic properties of the nanocomposite CoFe<sub>2</sub>O<sub>4</sub>/FeCoFeO at a high H/T regime</i>	<b>Journal of Magnetism and Magnetic Materials</b>	424	-	323	10.1016/j.jmmm.2016.10.079
X	Man, H.; Guo, J.; Zhang, R.; Schoenemann, R.U.; Yin, Z.; Fu, M.; Stone, M.B.; Huang, Q.; Song, Y.; Wang, W.; Singh, D.; Lochner, F.; Hickel, T.; Eremin, I.; Harriger, L.; Lynn, J.W.; Broholm, C.; Balicas, L.; Si, Q. and Dai, P.,	<i>Spin excitations and the Fermi surface of superconducting FeS</i>	<b>Nature Quantum Materials</b>	2	-	14	10.1038/s41535-017-0019-6
X	Maniv, E.; Dagan, Y. and Goldstein, M.,	<i>Correlation-Induced Band Competition in SrTiO<sub>3</sub>/LaAlO<sub>3</sub></i>	<b>MRS Advances</b>	2	23	1243	10.1557/adv.2017.92
X	Movva, H.C.P.; Fallahzad, B.; Kim, K.; Larentis, S.; Taniguchi, T.; Watanabe, W.; Banerjee, S.K. and Tutuc, E.,	<i>Density-Dependent Quantum Hall States and Zeeman Splitting in Monolayer and Bilayer WSe<sub>2</sub></i>	<b>Physical Review Letters</b>	118	-	247701	10.1103/PhysRevLett.118.247701

# Chapter 6 – Accomplishments & Discoveries

Cites NSF Core Grant	Authors	Title	Journal Name	Vol	Issue	Pages	DOI
X	Mueed, M.A.; Kamburov, D.; Hossain, Md. Shafayat; Pfeiffer, L.N.; West, K.W.; Baldwin, K.W. and Shayegan, M.,	<i>Search for composite fermions at filling factor 5/2: Role of Landau level and subband index</i>	<b>Physical Review B</b>	95	-	165438	10.1103/PhysRevB.95.165438
X	Nikolo, M.; Singleton, J.; Solenov, D.; Jiang, J.; Weiss, J.D. and Hellstrom, E.E.,	<i>Upper critical and irreversibility fields in Ba(Fe<sub>0.95</sub>Ni<sub>0.05</sub>)<sub>2</sub>As<sub>2</sub> and Ba(Fe<sub>0.94</sub>Ni<sub>0.06</sub>)<sub>2</sub>As<sub>2</sub> pnictide bulk superconductors</i>	<b>Journal of Superconductivity and Novel Magnetism</b>	30	-	331-341	10.1007/s10948-016-3726-5
X	O'Neal, K.; Patete, J.M.; Chen, P.; Nanavati, R.; Holinsworth, B.S.; Smith, J.M.; Marques, C.; Simonson, J.W.; Aronson, M.C.; McGill, S.A.; Wong, S.S.; and Musfeldt, J.L.,	<i>Magneto-chromic sensing and size-dependent collective excitations in iron oxide nanoparticles</i>	<b>Physical Review B</b>	95	-	125416-125427	10.1103/PhysRevB.95.125416
X	Pradhan, N.R.; Talapatra, S.; Terrones, M.; Pulickel, A. and Balicas, L.,	<i>Optoelectronic Properties of Heterostructures: The Most Recent Developments Based on Graphene and Transition-Metal Dichalcogenides</i>	<b>IEEE Nanotechnology Magazine</b>	11	2	18-32	10.1109/MNANO.2017.2676185
X	Ramshaw, B.J.; Harrison, N.; Sebastian, S.E.; Ghannad-zadeh, S.; Modic, K.A.; Bonn, D.A.; Hardy, W.N.; Liang, R. and Goddard, P.A.,	<i>Broken rotational symmetry on the fermi surface of a high-Tc superconductor.</i>	<b>Nature Quantum Materials</b>	2	8	1-6	10.1038/s41535-017-0013-z
X	Ran, S.; Jeon, I.; Pouse, N.; Breindel, A.J.; Kanchanavatee, N.; Huang, K.; Gallagher, A.; Chen, K.W.; Graf, D.; Baumbach, R.E.; Singleton, J. and Maple, M.B.,	<i>Phase diagram of URu<sub>2</sub>-xFe<sub>x</sub>Si<sub>2</sub> in high magnetic fields</i>	<b>Proceedings of the National Academy of Sciences of the United States of America</b>	114	37	9826-9831	10.1073/pnas.1710192114
X	Rawl, R.; Ge, L.; Agrawal, H.; Kamiya, Y.; Cruz, C.R.D.; Butch, N.P.; Sun, X.F.; Lee, M.; Choi, E.S.; Oitmaa, J.; Batista, C.; Mourigal, M.; Zhou, H.D. and Ma, J.,	<i>Ba<sub>8</sub>CoNb<sub>6</sub>O<sub>24</sub>: a spin-1/2 triangular-lattice Heisenberg antiferromagnet in the 2D limit</i>	<b>Physical Review B Rapid Communications</b>	95	-	60412	10.1103/PhysRevB.95.060412
X	Rawl, R.; Lee, M.; Choi, E.S.; Li, G.; Chen, K.W.; Baumbach, R.; Cruz, C.R.d.; Ma, J. and Zhou, H.D.,	<i>Magnetic properties of the triangular lattice magnets A<sub>4</sub>B'B<sub>2</sub>O<sub>12</sub> (A=Ba, Sr, La; B'=Co, Ni, Mn; B=W, Re)</i>	<b>Physical Review B</b>	95	-	174438	10.1103/PhysRevB.95.174438
X	Rhodes, D.; Schoenemann, R.; Aryal, N.; Zhou, Q.; Zhang, Q.R.; Kampert, E.; Chiu, Y.-C.; Lai, Y.; Shimura, Y.; McCandless, G.T.; Chan, J.Y.; Paley, D.W.; Lee, J.; Finke, A.D.; Ruff, J.P.C.; Das, S.; Manousakis, E., and Balicas, L.,	<i>Bulk Fermi-surface of the Weyl type-II semi-metallic candidate gamma-MoTe<sub>2</sub></i>	<b>Physical Review B</b>	96	-	165134	10.1103/PhysRevB.96.165134

# Chapter 6 – Accomplishments & Discoveries

Cites NSF Core Grant	Authors	Title	Journal Name	Vol	Issue	Pages	DOI
X	Richter, S.; Kurth, F.; Iida, K.; Pervakov, K.; Pukenas, A.; Tarantini, C.; Jaroszynski, J.; Hanisch, J.; Grinenko, V.; Skrotzki, W.; Nielsch, K. and Huhne, R.,	<i>Superconducting properties of Ba(Fe<sub>1-x</sub>Ni<sub>x</sub>)<sub>2</sub>As<sub>2</sub> thin films in high magnetic fields</i>	<b>Applied Physics Letters</b>	110	-	22601	10.1063/1.4973522
X	Ron, A.; Hevroni, A.; Maniv, E.; Mograbi, M.; Jin, L.; Jia, C.L.; Urban, K.W.; Markovich, G. and Dagan, Y.,	<i>Solution Monolayer Epitaxy for Tunable Atomically Sharp Oxide Interfaces</i>	<b>Advanced Materials Interfaces</b>	2017	-	1700688	10.1002/admi.201700688
X	Ronning, F.; Helm, T.; Shirer, K.; Bachmann, M.; Balicas, L.; Chan, M.; Ramshaw, B.; McDonald, R.; Balakirev, F.; Bauer, E.; Jaime, M. and Moll, P.,	<i>Electronic in-plane symmetry breaking at field-tuned quantum criticality in CeRhIn<sub>5</sub></i>	<b>Nature</b>	548	-	313-317	10.1038/nature23315
X	Schoenemann, R.; Aryal, N.; Zhou, Q.; Chiu, Y.-C.; Chen, K.-W.; Martin, T.J.; McCandless, G.T.; Chan, J.Y.; Manousakis, E. and Balicas, L.,	<i>Fermi surface of the Weyl type-II semi-metallic candidate WP<sub>2</sub></i>	<b>Physical Review B Rapid Communications</b>	96	-	121108(R)	10.1103/PhysRevB.96.121108
X	Schweinfurth, D.; Krzystek, J.; Atanasov, M.; Klein, J.; Hohloch, S.; Telsler, J.; Demeshko, S.; Meyer, F.; Neese, F. and Sarkar, B.,	<i>Tuning magnetic anisotropy through ligand substitution in five-coordinate Co(II) complexes</i>	<b>Inorganic Chemistry</b>	56	-	5253-5265	10.1021/acs.inorgchem.7b00371
X	Shirer, K.R.; Lawson, M.; Kissikov, T.; Bush, B.T.; Gallagher, A.; Chen, K.-W.; Baumbach, R.E. and Curro, N.,	<i>NMR investigation of antiferromagnetism and coherence in URu<sub>2</sub>Si<sub>2-x</sub>P<sub>x</sub></i>	<b>Physical Review B</b>	95	-	41107	10.1103/PhysRevB.95.041107
X	Shrestha, K.; Chou, M.; Graf, D.; Yang, H.D.; Lorenz, B. and Chu, C.W.,	<i>Extremely large nonsaturating magnetoresistance and ultra-high mobility due to topological surface states in the metallic Bi<sub>2</sub>Te<sub>3</sub> topological insulator</i>	<b>Physical Review B</b>	95	19	195113	10.1103/PhysRevB.95.195113
X	Shrestha, K.; Graf, D.; Marinova, V.; Lorenz, B. and Chu, P.W.,	<i>Simultaneous detection of quantum oscillations from bulk and topological surface states metallic Bi<sub>2</sub>Se<sub>2.1</sub>Te<sub>0.9</sub></i>	<b>Philosophical Magazine A - Physics of Condensed Matter Structure Defects and Mechanical Properties</b>	97	20	1740-1754	10.1080/14786435.2017.1314563
X	Shrestha, K.; Marinova, V.; Graf, D.; Lorenz, B. and Chu, C.W.,	<i>Quantum oscillations in metallic Sb<sub>2</sub>Te<sub>2</sub>Se topological insulator</i>	<b>Physical Review B</b>	95	7	75102	10.1103/PhysRevB.95.075102
X	Sinclair, R.; Cao, H.; Garlea, V.; Lee, M.; Choi, E.S.; Dun, Z.; Dong, S.; Dagotto, E. and Zhou, H.,	<i>Canted Magnetic Ground State of Quarter-Doped Manganites R(0.75)Ca(0.25)MnO<sub>3</sub> (R = Y, Tb, Dy, Ho, and Er)</i>	<b>Journal of Physics-Condensed Matter</b>	29	-	065802-065812	10.1088/1361-648X/aa4de1
X	Sinclair, R.; Zhou, H.D.; Lee, M.; Choi, E.S.; Li, G.; Hong, T. and Calder, S.,	<i>Magnetic ground states and magnetodielectric effect of RCr(BO<sub>3</sub>)<sub>2</sub> (R= Y and Ho).</i>	<b>Physical Review B</b>	95	-	174410	10.1103/PhysRevB.95.174410

# Chapter 6 – Accomplishments & Discoveries

Cites NSF Core Grant	Authors	Title	Journal Name	Vol	Issue	Pages	DOI
X	Suturina, E.A.; Nehr Korn, J.; Zadrozny, J.M.; Liu, J.; Atanasov, M.; Weyhermüller, T.; Maganas, D.; Hill, S.; Schnegg, A.; Bill, E.; Long, J.R. and Neese, F.,	<i>Magneto-Structural Correlations in Pseudotetrahedral Forms of the [Co(SPh)<sub>4</sub>]<sup>2-</sup> Complex Probed by Magnetometry, MCD Spectroscopy, Advanced EPR Techniques, and ab Initio Electronic Structure Calculations</i>	<b>Inorganic Chemistry</b>	56	-	3102-3118	10.1021/acs.inorgchem.7b00097
X	Tran, S.; Yang, J.; Gillgren, N.; Espiritu, T.; Shi, Y.; Watanabe, K.; Taniguchi, T.; Moon, S.; Baek, H.; Smirnov, D.; Bockrath, M.; Chen, R. and Lau, C.N.,	<i>Surface transport and quantum Hall effect in ambipolar black phosphorus double quantum wells</i>	<b>Science Advances</b>	3	-	e1603179	10.1126/sciadv.1603179
X	VanGennep, D.; Jackson, D.E.; Graf, D.; Berger, H. and Hamlin J.J.,	<i>Evolution of the Fermi surface of BiTeCl with pressure</i>	<b>Journal of Physics-Condensed Matter</b>	29	29	295702	10.1088/1361-648X/aa73b7
X	Wang, A.; Graf, D.; Liu, Y.; Du, Q.H.; Zheng, J.B.; Lei, H.C. and Petrovic, C.,	<i>Large magnetoresistance in the type-II Weyl semimetal WP<sub>2</sub></i>	<b>Physical Review B</b>	96	12	121107	10.1103/PhysRevB.96.121107
X	Wang, A.F.; Graf, D.; Stein, A.; Liu, Y.; Yin, W.G. and Petrovic, C.,	<i>Magnetotransport properties of MoP<sub>2</sub></i>	<b>Physical Review B</b>	96	-	195107	10.1103/PhysRevB.96.195107
X	Wang, L.; Schmiedeshoff, G.M.; Graf, D.E.; Park, J.-H.; Murphy, T.P.; Tozer, S.W.; Palm, E.; Sarrao, J.L. and Cooley, J.C.,	<i>Application of an atomic force microscope piezocantilever for dilatometry under extreme conditions</i>	<b>Measurement Science and Technology</b>	28	6	65006	10.1088/1361-6501/aa62e2
X	Xiang, Z.; Lawson, B.; Asaba, T.; Tinsman, C.; Chen, L.; Shang, C.; Chen, X.H. and Li, L.,	<i>Bulk Rotational Symmetry Breaking in Kondo Insulator Smb<sub>6</sub></i>	<b>Physical Review X</b>	7	-	31054	10.1103/PhysRevX.7.031054
X	Yang, W.C.; Zhu, W.K.; Zhou, H.D.; Ling, L.; Choi, E.S.; Lee, M.; Losovyj, Y.; Lu, C.-K. and Zhang, S.X.,	<i>Robust pinning of magnetic moments in pyrochlore iridates</i>	<b>Physical Review B</b>	96	-	94437	10.1103/PhysRevB.96.094437
X	Ye, L.; Suzuki, T. and Checkelsky, J.G.,	<i>Electronic Transport on the Shastry-Sutherland Lattice in Ising-type Rare Earth Tetra-borides</i>	<b>Physical Review B</b>	95	-	174405	10.1103/PhysRevB.95.174405
X	Ye, L.Y.; Li, P.; Jaroszynski, J.; Schwartz, J. and Shen, T.M.,	<i>Strain control of composite superconductors to prevent degradation of superconducting magnets due to a quench: I. Ag/Bi<sub>2</sub>Sr<sub>2</sub>CaCu<sub>2</sub>O<sub>x</sub> multifilament round wires</i>	<b>Superconductor Science and Technology</b>	30	-	25005	10.1088/0953-2048/30/2/025005
X	Yuan, X.; Cheng, P.; Zhang, L.; Zhang, C.; Wang, J.; Liu, Y.; Sun, Q.; Zhou, P.; Zhang, D.W.; Hu, Z.; Wan, X.; Yan, H.; Li, Z. and Xiu, F.,	<i>Direct Observation of Landau Level Resonance and Mass Generation in Dirac Semimetal Cd<sub>3</sub>As<sub>2</sub> Thin Films</i>	<b>Nano Letters</b>	17	4	2211-2219	10.1021/acs.nanolett.6b04778
X	Zhang, P.; Liu, R.; Du, R.-R.; Pfeiffer, L.N. and West, K.W.,	<i>Composite fermion states around the two-dimensional hole Landau level filling factor 3/2 in tilted magnetic fields</i>	<b>Physical Review B</b>	95	-	155316	10.1103/PhysRevB.95.155316

# Chapter 6 – Accomplishments & Discoveries

Cites NSF Core Grant	Authors	Title	Journal Name	Vol	Issue	Pages	DOI
X	Zhang, S.; Aryal, N.; Huang, K.; Chen, K.-W.; Lai, Y.; Graf, D.; Besara, T.; Siegrist, T.; Manousakis, E. and Baumbach, R.E.,	<i>Electronic structure and magnetism in the layered triangular lattice compound CeAuAl<sub>4</sub>Ge<sub>2</sub></i>	<b>Phys. Rev. Materials</b>	1	-	44404	10.1103/PhysRevMaterials.1.044404
X	Zhang, X.-X.; Cao, T.; Lu, Z.; Lin, Y.-C.; Zhang, F.; Wang, Y.; Li, Z.; Hone, J.C.; Robinson, J.A.; Smirnov, D.; Louie, S.G. and Heinz, T.F.,	<i>Magnetic brightening and control of dark excitons in monolayer WSe<sub>2</sub></i>	<b>Nature Nanotechnology</b>	12	-	883	10.1038/nanano.2017.105
X	Zhou, R.; Hirata, M.; Wu, T.; Vinograd, I.; Mayaffre, H.; Krämer, S.; Horvatić, M.; Berthier, C.; Reyes, A.P.; Kuhns, P.L.; Liang, R.; Hardy, W.N.; Bonn, D.A. and Julien, M.-H.,	<i>Quasiparticle Scattering off Defects and Possible Bound States in Charge-Ordered YBa<sub>2</sub>Cu<sub>3</sub>O<sub>y</sub></i>	<b>Physical Review Letters</b>	118	-	17001	10.1103/PhysRevLett.118.017001
X	Zhou, R.; Hirata, M.; Wu, T.; Vinograd, I.; Mayaffre, H.; Kramer, S.; Reyes, A.P.; Kuhns, P.; Liang, R.; Hardy, W.; Bonn, D. and Julien, M.-H.,	<i>Spin susceptibility of charge-ordered YBa<sub>2</sub>Cu<sub>3</sub>O<sub>y</sub> across the upper critical field</i>	<b>Proceedings of the National Academy of Sciences of the United States of America</b>	114	50	13148-13153	10.1073/pnas.1711445114
X	Zhu, Z.; McDonald, R.D.; Shehter, A.; Ramshaw, B.J.; Modic, K.A.; Balakirev, F.F. and Harrison, N.,	<i>Magnetic Field Tuning of an Excitonic Insulator Between the Weak and Strong Coupling Regimes in Quantum Limit Graphite</i>	<b>Scientific Report</b>	7	-	1733	10.1038/s41598-017-01693-5
	Dixon, I.R.; Bole, S.T.; Cantrell, K.R.; Hannahs, S.T.; Kynoch, J.G.; Marshall, W.S.; Powell, A.A.; Toth, J. and Bird, M.D.,	<i>The 36-T Series-Connected Hybrid Magnet System Design and Integration</i>	<b>IEEE Transactions on Applied Superconductivity</b>	27	4	4300105	10.1109/TASC.2016.2628304
	Helm, T.; Flicker, F.; Kealhofer, R.; Moll, P.; Hayes, I.M.; Breznay, N.P.; Li, Z.; Louie, S.G.; Zhang, Q.R.; Balicas, L.; Moore, J.E. and Analytis, J.G.,	<i>Thermodynamic Anomaly Above the Superconducting Critical Temperature in the Quasi One-Dimensional Superconductor Ta<sub>4</sub>Pd<sub>3</sub>Te<sub>16</sub></i>	<b>Physical Review B</b>	95	-	75121	10.1103/PhysRevB.95.075121
	Jiao, L.; Weng, Z.F.; Smidman, M.; Graf, D.; Singleton, J.; Bauer, E.D.; Thompson, J.D. and Yuan, H.Q.,	<i>Magnetic field-induced Fermi surface reconstruction and quantum criticality in CeRhIn<sub>5</sub></i>	<b>Philosophical Magazine A - Physics of Condensed Matter Structure Defects and Mechanical Properties</b>	97	36	1-10	10.1080/14786435.2017.1282181
	O'Neal, K.R.; Lee, J.H.; Kim, M.; Manson, J.L.; Liu, Z.; Fishman, R.S. and Musfeldt, J.L.,	<i>Competing magnetostructural phases in a semiclassical system</i>	<b>Nature Quantum Materials</b>	2	-	65	10.1038/s41535-017-0065-0
	Paul, J.; Stevens, C.E.; Zhang, H.; Dey, P.; McGinty, D.; McGill, S.A.; Smith, R.P.; Reno, J.L.; Turkowski, V.; Perakis, I.E.; Hilton, D.J. and Karaiskaj, D.,	<i>Coulomb-interaction induced coupling of Landau levels in intrinsic and modulation-doped quantum wells</i>	<b>Physical Review B</b>	95	-	245314	10.1103/PhysRevB.95.245314

# Chapter 6 – Accomplishments & Discoveries

Cites NSF Core Grant	Authors	Title	Journal Name	Vol	Issue	Pages	DOI
	Zou, W.; Wang, W.; Kou, X.; Lang, M.; Fan, Y.; Choi, E.S.; Fedorov, A.V.; Wang, K.; He, L.; Xu, Y. and Wang, K.L.,	<i>Observation of Quantum Hall effect in an ultra-thin (Bi<sub>0.53</sub>Sb<sub>0.47</sub>)<sub>2</sub>Te<sub>3</sub> film.</i>	<b>Applied Physics Letters</b>	110	-	212401	10.1063/1.4983684

## 6.3. EMR Facility at FSU

Cites NSF Core Grant	Authors	Title	Journal Name	Vol	Issue	Pages	DOI
X	Bortolus, M.; Dalzini, A.; Maniero, A.L.; Panighel, G.; Siano, A.; Toniolo, C.; De Zotti, M. and Formaggio, F.,	<i>Insights into Peptide-Membrane Interactions of Newly Synthesized, Nitroxide-Containing Analogs of the Peptaibiotic Trichogin GA IV Using EPR</i>	<b>Biopolymers: Peptide Science</b>	108	1	1-28	10.1002/bip.22913
X	Brown, C.; Lita, A.; Tao, Y.; Peek, N.; Crosswhite, M.; Mileham, M.; Krzystek, J.; Achey, R.; Fu, R.; Bindra, J.K.; Polinski, M.; Wang, Y.; van de Burgt, L.J.; Jeffcoat, D.; Profeta, Jr., S.; Stiegman, A.E. and Scott, S.L.,	<i>Mechanism of initiation in the Phillips ethylene polymerization catalyst: ethylene activation by Cr(II) and the structure of the resulting active site</i>	<b>American Chemical Society Catalysis</b>	7	-	7442-7455	10.1021/acs.catal.7b02677
X	Brozek, C.K.; Ozarowski, A.; Stoian, S.A. and Dinca, M.,	<i>Dynamic structural flexibility of Fe-MOF-5 evidenced by 57Fe Mössbauer spectroscopy</i>	<b>Inorganic Chemistry Frontiers</b>	4	-	782-788	10.1039/C6QI00584E
X	Bruno, R.; Vallejo, J.; Marino, N.; De Munno, G.; Krzystek, J.; Cano, J.; Pardo, E. and Armentano, D.,	<i>Cytosine nucleobase ligand: a suitable choice to modulate magnetic anisotropy in tetrahedral coordinated mononuclear Co(II) compounds</i>	<b>Inorganic Chemistry</b>	56	-	1857-1864	10.1021/acs.inorgchem.6b02448
X	Bucinsky, L.; Breza, M.; Lee, W.-T.; Hickey, A.K.; Dickie, D.A.; Nieto, I.; DeGayner, J.A.; Harris, T.D.; Meyer, K.; Krzystek, J.; Ozarowski, A.; Nehrkorn, J.; Schnegg, A.; Holldack, K.; Herber, R.H.; Telser, J. and Smith, J.M.,	<i>Spectroscopic and computational studies of spin states of iron(IV) nitrido and imido complexes</i>	<b>Inorganic Chemistry</b>	56	-	4751-4768	10.1021/acs.inorgchem.7b00512
X	Buvaylo, E.A.; Kokozay, V.N.; Vassilyeva, O.Y.; Skelto, B. W.; Ozarowski, A.; Titis, J.; Vranovicova, B. and Boca, R.,	<i>Field-Assisted Slow Magnetic Relaxation in a Six-Coordinate Co(II)-Co(III) Complex with Large Negative Anisotropy</i>	<b>Inorganic Chemistry</b>	56	12	6999-7009	10.1021/acs.inorgchem.7b00605
X	DeHaven, B.A.; Tokarski, J.T., III.; Korous, A.A.; Mentink-Vigier, F.; Makris, T.M.; Brugh, A.M.; Forbes, M.D.E.; van Tol, J.; Bowers, C.R. and Shimizu, L.S.,	<i>Persistent Radicals of Self-assembled Benzophenone bis-urea Macrocycles: Characterization and Application as a Polarizing Agent for Solid-state DNP MAS Spectroscopy</i>	<b>Chemistry a European Journal</b>	23	-	1-6	10.1002/chem.201701705
X	Dubroca, T.; McKay, J.; Wang, X. and van Tol, J.,	<i>Time Domain Measurement of Electron Spin Relaxation at High Fields and Dynamic Nuclear Polarization at Sub-Millimeter Wavelengths</i>	<b>IEEE International Microwave Symposium proceeding (peer reviewed)</b>	1	-	1	10.1109/MWSYM.2017.8058878

# Chapter 6 – Accomplishments & Discoveries

Cites NSF Core Grant	Authors	Title	Journal Name	Vol	Issue	Pages	DOI
X	Grubba, R.; Kaniewska, K.; Ponikiewski, Ł.; Cristóvão, B.; Ferenc, W.; Dragulescu-Andrasi, A.; Krzystek, J.; Stoian, S.A. and Pikies, J.,	<i>Synthetic, structural and spectroscopic characterization of a novel family of high-spin iron(II) [(beta-diketimi-nate)(phosphanylphosphido)] complexes</i>	<b>Inorganic Chemistry</b>	56	-	11030-11042	10.1021/acs.inorgchem.7b01374
X	Hoch, M.J.R.,	<i>Spin clusters and low energy excitations in rare earth kagome systems</i>	<b>Modern Physics Letters B</b>	31	1	1630010-1 - 1630010-24	10.1142/S0217984916300106
X	Jakes, P.; Kröll, L.; Ozarowski, A.; van Tol, J.; Mikhailova, D.; Ehrenberg, H. and Eichel, R.,	<i>Coordination of the Mn4+-Center in Layered Li[Co0.98Mn0.02]O2 Cathode Materials for Lithium-Ion Batteries</i>	<b>Zeitschrift für Physikalische Chemie</b>	231	4	905-922	10.1515/zpch-2016-0909
X	Jenkins, T.A.; Garnero, M.; Corrales, S.A.; Williams, E.R.; Mowson, A.R.; Ozarowski, A.; Wernsdorfer, W.; Christou, C. and Lampropoulos, C.,	<i>Controlled Dimerization of Mn12 Single-Molecule Magnets</i>	<b>Inorganic Chemistry</b>	56	-	14755-14758	10.1021/acs.inorgchem.7b02640
X	Juric, M.; Dubraja, L.A.; Pajic, D.; Toric, F.; Zorko, A.; Ozarowski, A.; Despoja, V.; Lafargue-Dit-Hauret, W. and Rocquefelte, X.,	<i>Experimental and Theoretical Investigation of the Anti Ferromagnetic Coupling of Cr-III Ions through Diamagnetic -O-Nb-V-O- Bridges</i>	<b>Inorganic Chemistry</b>	56	12	6879-6889	10.1021/acs.inorgchem.7b00181
X	Lee, S.; Lee, W.-J.; van Tol, J.; Kuhns, P.L.; Reyes, A.P.; Berger, H. and Choi, K.-Y.,	<i>Anomalous spin dynamics in the coupled spin tetramer system CuSeO<sub>3</sub></i>	<b>Physical Review B</b>	95	-	54405	10.1103/PhysRevB.95.054405
X	Martens, M.; Franco-Rivera, G.; Dalal, N.S.; Bertaina, S. and Chiorescu, I.,	<i>Spin-orbit coupling fluctuations as a mechanism of spin decoherence</i>	<b>Physical Review B Rapid Communications</b>	96	-	180408(R)	10.1103/PhysRevB.96.180408
X	McElhinney, P.; Donaldson, C.R.; McKay, J.E.; Zhang, L.; Robertson, D.A.; Hunter, R.I.; Smith, G.M.; He, W. and Cross, A.W.,	<i>An Output Coupler for a W-Band High Power Wideband Gyroamplifier</i>	<b>IEEE Transactions on Electron Devices</b>	64	4	1763 - 1766	10.1109/TED.2017.2660304
X	Niedbalski, P.; Parish, C.; Kiswandhi, A.; Fidelino, L.; Khemtong, C.; Hayati, Z.; Song, L.; Martins, A.; Sherry, A.D. and Lumata, L.,	<i>Influence of Dy3+ and Tb3+ doping on 13C dynamic nuclear polarization</i>	<b>Journal of Chemical Physics</b>	146	1	14303	10.1063/1.4973317
X	Niedbalski, P.; Parish, C.; Wang, Q.; Hayati, Z.; Song, L.; Cleveland, Z.I. and Lumata, L.,	<i>Enhanced Efficiency of 13C Dynamic Nuclear Polarization by Superparamagnetic Iron Oxide Nanoparticle Doping</i>	<b>Journal of Physical Chemistry C</b>	121	35	19505-19511	10.1021/acs.jpcc.7b06408
X	Niedbalski, P.; Parish, C.; Wang, Q.; Hayati, Z.; Song, L.; Martins, A.F.; Sherry, A.D. and Lumata, L.,	<i>Transition Metal Doping Reveals Link between Electron T1 Reduction and 13C Dynamic Nuclear Polarization Efficiency</i>	<b>Journal of Physical Chemistry A</b>	121	48	9221-9228	10.1021/acs.jpca.7b09448
X	Niedbalski, P.; Parish, C.; Wang, Q.; Kiswandhi, A.; Hayati, Z.; Song, L. and Lumata, L.,	<i>13C Dynamic Nuclear Polarization Using a Trimeric Gd3+ Complex as an Additive</i>	<b>Journal of Physical Chemistry A</b>	121	27	5127-5135	10.1021/acs.jpca.7b03869



# Chapter 6 – Accomplishments & Discoveries

Cites NSF Core Grant	Authors	Title	Journal Name	Vol	Issue	Pages	DOI
X	Palacios, M.A.; Nehr Korn, J.; Suturina, E.A.; Ruiz, E.; Gómez-Coca, S.; Holldack, K.; Schnegg, A.; Krzystek, J.; Moreno, J.M. and Colacio, E.,	<i>Analysis of magnetic anisotropy and the role of magnetic dilution in triggering single-molecule magnet (SMM) behavior in a family of Co(II)Y(III) dinuclear complexes with easy-plane anisotropy</i>	<b>Chemistry a European Journal</b>	23	-	11649-11661	10.1002/chem.201702099
X	Pan, J.; Sahoo, P.K.; Dalzini, A.; Hayati, Z.; Aryal, C.M.; Teng, P.; Cai, J.; Rodriguez Gutierrez, H. and Song, L.,	<i>Membrane Disruption Mechanism of a Prion Peptide (106-126) Investigated by Atomic Force Microscopy, Raman and Electron Paramagnetic Resonance Spectroscopy</i>	<b>Journal of Physical Chemistry B</b>	121	19	5058-5071	10.1021/acs.jpcc.7b02772
X	Reger, D.L.; Pascui, A.E.; Foley, E.A.; Smith, M.D.; Jezierska, J.; Wojciechowska, A.; Stoian, S. A. and Ozarowski, A.,	<i>Dinuclear Metallacycles with Single M<sub>2</sub>X<sub>2</sub>M Bridges (X = Cl<sup>−</sup>, Br<sup>−</sup>; M = Fe(II), Co(II), Ni(II), Cu(II), Zn(II), Cd(II)): Strong Antiferromagnetic Superexchange Interactions</i>	<b>Inorganic Chemistry</b>	56	-	2884–2901	10.1021/acs.inorgchem.6b02933
X	Sakiyama, H.; Chiba, Y.; Tone, K.; Yamasaki, M.; Mikuriya, M.; Krzystek, J. and Ozarowski, A.,	<i>Magnetic properties of a dinuclear nickel(II) complex with 2,6-bis[(2-hydroxyethyl)methylaminomethyl]-4-methylphenolate</i>	<b>Inorganic Chemistry</b>	56	-	138-146	10.1021/acs.inorgchem.6b01671
X	Schweinfurth, D.; Krzystek, J.; Atanasov, M.; Klein, J.; Hohloch, S.; Telsler, J.; Demeshko, S.; Meyer, F.; Neese, F. and Sarkar, B.,	<i>Tuning magnetic anisotropy through ligand substitution in five-coordinate Co(II) complexes</i>	<b>Inorganic Chemistry</b>	56	-	5253-5265	10.1021/acs.inorgchem.7b00371
X	Sharma, A.; Gaidamakova, E.K.; Grichenko, O.; Matrosova, V. Y.; Hoeke, V.; Klimenkova, P.; Conze, I.H.; Volpe, R.P.; Tkavc, R.; Gostin'car, C.; Gunde-Cimerman, N.; DiRuggiero, J.; Shuryak, I.; Ozarowski, A.; Hoffman, B.M. and Daly, M.J.,	<i>Across the tree of life, radiation resistance is governed by antioxidant Mn<sup>2+</sup>, gauged by paramagnetic resonance</i>	<b>Proceedings of the National Academy of Sciences of the United States of America</b>	114	44	E9253-E9260	10.1073/pnas.1713608114
X	Shova, S.; Vlad, A.; Cazacu, M.; Krzystek, J.; Bucinsky, L.; Breza, M.; Darvasiova, D.; Rapta, P.; Cano, J.; Telsler, J. and Arion, V.B.,	<i>A five-coordinate manganese(III) complex of a salen type ligand with a positive axial anisotropy parameter D</i>	<b>Dalton Transactions in Chemistry</b>	46	35	11817-11829	10.1039/C7DT01809F
X	Simon, U.; Villaseca, S.A.; Shang, H.; Levchenko, S.V.; Arndt, S.; Epping, J.D.; Görke, O.; Scheffler, M.; Schomacker, R.; van Tol, J.; Ozarowski, A. and Dinse, K.-P.,	<i>Li/MgO Catalysts Doped with Alio-valent Ions. Part II: Local Topology Unraveled by EPR/NMR and DFT Modeling</i>	<b>ChemCatChem</b>	2017	9	3597-3610	10.1002/cctc.201700610
X	Stoian, S.A.; Peng, Y.-R.; Beedle, C.C.; Chung, Y.-C.; Lee, G.-L.; Yang, E.-C. and Hill, S.,	<i>Structural, Spectroscopic, and Theoretical Investigation of a T-Shaped [Fe<sub>3</sub>(μ<sub>3</sub>-O)] Cluster</i>	<b>Inorganic Chemistry</b>	56	18	10861	10.1021/acs.inorgchem.7b00455

# Chapter 6 – Accomplishments & Discoveries

Cites NSF Core Grant	Authors	Title	Journal Name	Vol	Issue	Pages	DOI
X	Suturina, E.A.; Nehr Korn, J.; Zadrozny, J.M.; Liu, J.; Atanasov, M.; Weyhermüller, T.; Maganas, D.; Hill, S.; Schnegg, A.; Bill, E.; Long, J.R. and Neese, F.,	<i>Magneto-Structural Correlations in Pseudotetrahedral Forms of the [Co(SPh)<sub>4</sub>]<sup>2-</sup> Complex Probed by Magnetometry, MCD Spectroscopy, Advanced EPR Techniques, and ab Initio Electronic Structure Calculations</i>	<b>Inorganic Chemistry</b>	56	-	3102-3118	10.1021/acs.inorgchem.7b00097
X	Tang, M.; Dalzini, A.; Li, X.; Feng, X.; Chien, P.-H.; Song, L. and Hu, Y.Y.,	<i>Operando EPR for Simultaneous Monitoring of Anionic and Cationic Redox Processes in Li-Rich Metal Oxide Cathodes</i>	<b>Journal of Physical Chemistry Letters</b>	8	-	4009-4016	10.1021/acs.jpcclett.7b01425
X	Vallejo, J.; Pardo, E.; Viciano-Chumillas, M.; Castro, I.; Amoros, P.; Deniz, M.; Ruiz-Perez, C.; Yuste-Vivas, C.; Krzystek, J.; Julve, M.; Lloret, F. and Cano, J.,	<i>Reversible solvatomagnetic switching in a single-ion magnet from an entatic state</i>	<b>Chemical Science</b>	8	-	3694-3702	10.1039/C6SC05188J
X	Wang, Z.; Seehra, M.S.; Bindra, J.; van Tol, J. and Dalal, N.S.,	<i>Magnetic studies reveal near-perfect paramagnetism in the molecular semiconductor vanadyl phthalocyanine (C<sub>32</sub>H<sub>16</sub>N<sub>8</sub>VO)</i>	<b>Journal of Magnetism and Magnetic Materials</b>	422	-	386-390	10.1016/j.jmmm.2016.09.018
X	Xu, S.; Bucinsky, L.; Breza, M.; Krzystek, J.; Chen, C.-H.; Pink, M.; Telsler, J. and Smith, J.M.,	<i>Ligand substituent effects in manganese pyridinophane complexes: implications for oxygen-evolving catalysis</i>	<b>Inorganic Chemistry</b>	56	-	14315-14325	10.1021/acs.inorgchem.7b02421
	Yergeshbayeva, S.; Hrudka, J.J.; Lengyel, J.; Erkasov, R.; Stoian, S.A.; Dragulescu-Andrasi, A. and Shatruck, M.,	<i>Heteroleptic Fe(II) Complexes with N<sub>4</sub>S<sub>2</sub> Coordination as a Platform for Designing Spin-Crossover Materials</i>	<b>Inorganic Chemistry</b>	56	18	11096	10.1021/acs.inorgchem.7b01415
	Zhang, M.; Yang, T.; Wang, Z.; Ma, X.-F.; Zhang, Y., Greer, S.M.; Stoian, S.; Ouyang, Z.-W.; Nojiri, H., Kurmoo, M. and Zeng, M.-H.,	<i>Chemical reaction within a compact non-porous crystal containing molecular clusters without the loss of crystallinity</i>	<b>Chemical Science</b>	8	-	5356-5361	10.1039/C7SC01041A
	Zorko, A.; Herak, M.; Gomilšek, M.; van Tol, J.; Velázquez, M.; Khuntia, P.; Bert, F. and Mendels, P.,	<i>Symmetry Reduction in the Quantum Kagome Antiferromagnet Herbertsmithite</i>	<b>Physical Review Letters</b>	118	-	17202	10.1103/PhysRevLett.118.017202

## 6.4. High B/T Facility at UF

Cites NSF Core Grant	Authors	Title	Journal Name	Vol	Issue	Pages	DOI
X	Huan, C.; Yin, L.; Xia, J.S.; Cowan, D., Sullivan, N. S. and Candela, D.,	<i>Phase separation in dilute solutions of <sup>3</sup>He in solid <sup>4</sup>He</i>	<b>Physical Review B</b>	95	-	104107	10.1103/PhysRevB.95.104107
	Peprah, M.; VanGennep, D.; Quintero, P.; Risset, O.; Brinzari, T.; Li, C.; Dumont, M.; Xia, J.; Hamlin, J.; Talham, D. and Meisel, M.,	<i>Photomagnetic response of heterostructured CoFe-CrCr-PBA core-shell nanoparticles</i>	<b>Am. Chem. Soc. Polyhedra</b>	123	-	323	10.1021/jacs.5b04303
X	Sullivan, N.S.; Hamida, J.A.; Muttalib, K.; Pilla, S. and Genio, E.,	<i>Oriental Glasses: NMR and Electric Susceptibility Studies</i>	<b>Magnetochemistry</b>	3	4	33-54	10.3390/magnetochemistry3040033

# Chapter 6 – Accomplishments & Discoveries

Cites NSF Core Grant	Authors	Title	Journal Name	Vol	Issue	Pages	DOI
X	VanGennep, D.; Linscheld, A.; Jackson, D.E.; Weor, S.T.; Vohra, Y.K.; Berger, H.; Stewart, G.R.; Hennig, R.G.; Hirschfeld, P.J. and Hamlin, J.J.,	<i>Pressure-induced superconductivity in the giant Rashba system BiTeI</i>	<b>Journal of Physics-Condensed Matter</b>	29	9	09LT02	10.1088/1361-648X/aa5567
X	Xia, J.S.; Yin, L.; Sullivan, N.S.; Zapf, V.S. and Paduan-Filho, A.,	<i>Magneto-electric Effect and Dielectric Susceptibility Measurement Technique at Very Low Temperature</i>	<b>Journal of Low Temperature Physics</b>	187	-	627	10.1007/s10909-016-1723-5
	Zheng, P.; Jiang, W.G.; Barquist, C.S.; Lee, Y. and Cha, H.B.,	<i>Anomalous Resonance Frequency Shift of a Microelectromechanical Oscillator in Superfluid <sup>3</sup>He-B</i>	<b>Journal of Low Temperature Physics</b>	187	3	309-323	10.1007/s10909-017-1752-8
	Zheng, P.; Jiang, W.G.; Barquist, C.S.; Lee, Y. and Chan, H.B.,	<i>Critical velocity in the Presence of Surface Bound Superfluid He-3-B</i>	<b>Physical Review Letters</b>	118	6	65301	10.1103/PhysRevLett.118.065301

## 6.5. ICR Facility at FSU

Cites NSF Core Grant	Authors	Title	Journal Name	Vol	Issue	Pages	DOI
X	Krajewski, L.C.; Rodgers, R.P. and Marshall, A.G.,	<i>126 264 Assigned Chemical Formulas from an Atmospheric Pressure Photoionization 9.4 T Fourier Transform Positive Ion Cyclotron Resonance Mass Spectrum</i>	<b>Analytical Chemistry</b>	89	21	11318-11324	10.1021/acs.analchem.7b02004
X	Putman, J.C.; Rowland, S.M.; Podgorski, D.C.; Robbins, W.K. and Rodgers, R.P.,	<i>A Dual-Column Aromatic Ring Class Separation with Improved Universal Detection across Mobile-Phase Gradients via Eluate Dilution</i>	<b>Energy &amp; Fuels</b>	31	11	12064-12071	10.1021/acs.energyfuels.7b02589
X	Wang, C.; He, L.; Li, D.; Bruschiweiler-Li, L.; Marshall, A.G. and Brüschiweiler, R.,	<i>Accurate Identification of Unknown and Known Metabolic Mixture Components by Combining 3D NMR with Fourier Transform Ion Cyclotron Resonance Tandem Mass Spectrometry</i>	<b>Journal of Proteome Research</b>	16	10	3774-3786	10.1021/acs.jproteome.7b00457
X	Avneri-Katz, S.; Young, R.B.; McKenna, A.M.; Chen, H.; Corilo, Y.E.; Polubesova, T.; Borch, T. and Chefetz, B.,	<i>Adsorptive Fractionation of Dissolved Organic Matter (DOM) by Mineral Soil: Macroscale Approach and Molecular Insight</i>	<b>Organic Geochemistry</b>	103	-	113-124	10.1016/j.orggeochem.2016.11.004
X	Ware, R.L.; Rowland, S.M.; Rodgers, R.P. and Marshall, A.G.,	<i>Advanced Chemical Characterization of Pyrolysis Oils from Landfill Waste, Recycled Plastics, and Forestry Residue</i>	<b>Energy &amp; Fuels</b>	31	8	8210-8216	10.1021/acs.energyfuels.7b00865
X	Chacon Patino, M.; Rowland, S.M. and Rodgers, R.P.,	<i>Advances in Asphaltene Petroleomics. Part 1: Asphaltenes Are Composed of Abundant Island and Archipelago Structural Motifs</i>	<b>Energy &amp; Fuels</b>	31	12	13509-13518	10.1021/acs.energyfuels.7b02873
X	He, L.; Anderson, L.C.; Barnidge, D.R.; Murray, D.L.; Hendrickson, C.L. and Marshall, A.G.,	<i>Analysis of Monoclonal Antibodies in Human Serum as a Model for Clinical Monoclonal Gammopathy by Use of 21 Tesla FT-ICR Top-Down and Middle-Down MS/MS</i>	<b>Journal of the American Society for Mass Spectrometry</b>	28	5	827-838	10.1007/s13361-017-1602-6
X	Manning, T.; Plummer, S.; Woods, R.; Wylie, G.; Phil-	<i>Cell Line Studies and Analytical Measurements of Three Paclitaxel</i>	<b>Bioorganic &amp; Medicinal Chemistry Let-</b>	27	12	2793-2799	10.1016/j.bmcl.2017.04.070

# Chapter 6 – Accomplishments & Discoveries

Cites NSF Core Grant	Authors	Title	Journal Name	Vol	Issue	Pages	DOI
	lips, D. and Krajewski, L.,	<i>Complex Variations</i>	<b>ters</b>				
X	D'Andrilli, J.; Smith, H.J.; Dieser, M. and Foreman, C.M.,	<i>Climate Driven Carbon and Microbial Signatures Through the Last Ice Age</i>	<b>Geochemical Perspectives Letters</b>	4	-	29-34	10.7185/geochemlet.1732
X	Giraldo-Dávila, D.; Chacón-Patiño, M.L.; McKenna, A.M.; Blanco-Tirado, C. and Combariza, M.Y.,	<i>Correlations between molecular composition and the adsorption, aggregation and emulsifying behavior of Petrophase 2017 asphaltenes and their TLC fractions</i>	<b>Energy &amp; Fuels</b>	0	0	0	10.1021/acs.energyfuels.7b02859
X	Clingenpeel, A.C.; Rowland, S.M.; Corilo, Y.E.; Zito, P. and Rodgers, R.P.,	<i>Fractionation of Interfacial Material Reveals a Continuum of Acidic Species That Contribute to Stable Emulsion Formation</i>	<b>Energy &amp; Fuels</b>	31	6	5933-5939	10.1021/acs.energyfuels.7b00490
X	Weisbrod, C.R.; Kaiser, N.K.; Syka, J.E.P.; Early, L.; Mullen, C.; Dunyach, J.J.; English, A.M.; Anderson, L.C.; Blakney, G.T.; Shabanowitz, J.; Hendrickson, C.L.; Marshall, A.G. and Hunt, D.F.,	<i>Front-End Electron Transfer Dissociation Coupled to a 21Tesla FT-ICR Mass Spectrometer for Intact Protein Sequence Analysis</i>	<b>Journal of the American Society for Mass Spectrometry</b>	28	9	1787-1795	10.1007/s13361-017-1702-3
X	Lalli, P.M.; Jarvis, J.M.; Marshall, A.G. and Rodgers, R.P.,	<i>Functional Isomers in Petroleum Emulsion Interfacial Material Revealed by Ion Mobility Mass Spectrometry and Collision-Induced Dissociation</i>	<b>Energy &amp; Fuels</b>	31	1	311-318	10.1021/acs.energyfuels.6b02411
X	Jarvis, J.M.; Billing, J.M.; Hallen, R.T.; Schmidt, A.J. and Schaub, T.M.,	<i>Hydrothermal Liquefaction Biocrude Compositions Compared to Petroleum Crude and Shale Oil</i>	<b>Energy &amp; Fuels</b>	31	3	2896-2906	10.1021/acs.energyfuels.6b03022
X	Anderson, L.C.; DeHart, C.J.; Kaiser, N.K.; Fellers, R.T.; Smith, D.F.; Greer, J.B.; LeDuc, R.D.; Blakney, G.T.; Thomas, P.M.; Kelleher, N.L. and Hendrickson, C.L.,	<i>Identification and Characterization of Human Proteoforms by Top-Down LC-21 Tesla FT-ICR Mass Spectrometry</i>	<b>Journal of Proteome Research</b>	16	2	1087-1096	10.1021/acs.jproteome.6b00696
X	Harriman, B.H.; Zito, P.; Podgorski, D.C.; Tarr, M.A. and Suflita, J.M.,	<i>Impact of Photooxidation and Biodegradation on the Fate of Oil Spilled During the Deepwater Horizon Incident: Advanced Stages of Weathering</i>	<b>Environmental Science &amp; Technology</b>	51	13	7412-7421	10.1021/acs.est.7b01278
X	Anderson, L.C.; Hakansson, M.; Walse, B. and Nilsson, C.L.,	<i>Intact Protein Analysis at 21 Tesla and X-Ray Crystallography Define Structural Differences in Single Amino Acid Variants of Human Mitochondrial Branched-Chain Amino Acid Aminotransferase 2 (BCAT2)</i>	<b>Journal of the American Society for Mass Spectrometry</b>	28	9	1796-1804	10.1007/s13361-017-1705-0
X	Tao, Y.; Fang, P.; Kim, S.; Guo, M.; Young, N.L. and Marshall, A.,	<i>Mapping the Contact Surfaces in the Lamin A:AIMP3 Complex by Hydrogen/Deuterium Exchange FT-ICR Mass Spectrometry</i>	<b>PLoS ONE</b>	12	8	19-Jan	10.1371/journal.pone.0181869

# Chapter 6 – Accomplishments & Discoveries

Cites NSF Core Grant	Authors	Title	Journal Name	Vol	Issue	Pages	DOI
X	Cawley, K.M.; Hohner, A.K.; Podgorski, D.C.; Cooper, W.T.; Korak, A.N. and Rosario-Ortiz, F.L.,	<i>Molecular and Spectroscopic Characterization of Water Extractable Organic Matter from Thermally Altered Soils Reveal Insight into Disinfection Byproduct Precursors</i>	<b>Environmental Science &amp; Technology</b>	51	2	771-779	10.1021/acs.est.6b05126
X	Pisani, O.; Boyer, J.N.; Podgorski, D.C.; Thomas, C.R.; Coley, T. and Jaffé, R.,	<i>Molecular Composition and Bioavailability of Dissolved Organic Nitrogen in a Lake Flow-induced River in South Florida, USA</i>	<b>Aquatic Sciences</b>	1	-	18-Jan	10.1007/s00027-017-0540-5
X	Hagemann, N.; Joseph, S.; Schmidt, H.-P.; Kammann, C.I.; Harter, J.; Borch, T.; Young, R.B.; Varga, K.; Taherymoosavi, S.; Elliott, K.W.; McKenna, A.; Albu, M.; Mayrhofer, C.; Obst, M.; Conte, P.; Dieguez-Alonso, A.; Orsetti, S.; Subdiaga, E.; Behrens, S. and Kappler, A.,	<i>Organic Coating on Biochar Explains its Nutrient Retention and Stimulation of Soil Fertility</i>	<b>Nature Communications</b>	8	1	1089	10.1038/s41467-017-01123-0
X	Manning, T.J.; Wilkerson, K.; Holder, T.; Bentley, A.C.; Jackson, C.; Plummer, S.; Phillips, D.; Krajewski, L. and Wylie, G.,	<i>Pharmacokinetic Studies of a Three-Component Complex that Repurposes the Front Line Antibiotic Isoniazid Against Mycobacterium Tuberculosis</i>	<b>Tuberculosis</b>	107	-	149-155	10.1016/j.tube.2017.08.011
X	Tian, S.; Yu, G; He, H.; Zhao, Y.; Liu, P.; Marshall, A.G.; Demeler, B.; Stagg, S.M. and Li, H.,	<i>Pih1p-Tah1p Puts a Lid on Hexameric AAA+ ATPases Rvb1/2p</i>	<b>Structure</b>	25	10	1519-1529	10.1016/j.str.2017.08.002
X	McCabe, A.J. and Arnold, W.A.,	<i>Reactivity of Triplet Excited States of Dissolved Natural Organic Matter in Stormflow from Mixed-Use Watersheds</i>	<b>Environmental Science &amp; Technology</b>	51	17	9718-9728	10.1021/acs.est.7b01914
X	Cefon, M.R.; Castro, E.; Neti, V.S.P.K.; Dunk, P.W. and Echegoyen, L.A.,	<i>Regiochemically Controlled Synthesis of a <math>\beta</math>-4-<math>\beta'</math> [70]Fullerene Bis-Adduct</i>	<b>Journal of Organic Chemistry</b>	82	2	893-897	10.1021/acs.joc.6b02301
X	Borotto, N.B.; McClory, P.J.; Martin, B.R. and Hakansson, K.,	<i>Targeted Annotation of S-Sulfonylated Peptides by Selective Infrared Multiphoton Dissociation Mass Spectrometry</i>	<b>Analytical Chemistry</b>	89	16	8304-8310	10.1021/acs.analchem.7b01461
X	Li, X.; Tao, Y.; Murphy, J.W.; Scherer, A.N.; Lam, T.T.; Marshall, A.G.; Koleske, A.J. and Boggon, T.J.,	<i>The Repeat Region of Cortactin is Intrinsically Disordered in Solution</i>	<b>Scientific Report</b>	7	1	10-Jan	10.1038/s41598-017-16959-1
X	Mulet-Gas, M.; Abella, L.; Ceron, M.R.; Castro, E.; Marshall, A.G.; Rodriguez-Fortea, A.; Echegoyen, L.; Poblet, J.M. and Dunk, P.W.,	<i>Transformation of Doped Graphite into Cluster-Encapsulated Fullerene Cages</i>	<b>Nature Communications</b>	8	-	1222	10.1038/s41467-017-01295-9

# Chapter 6 – Accomplishments & Discoveries

Cites NSF Core Grant	Authors	Title	Journal Name	Vol	Issue	Pages	DOI
X	Guan, X.; Brownstein, N.C.; Young, N.L. and Marshall, A.G.,	<i>Ultrahigh-Resolution Fourier Transform Ion Cyclotron Resonance Mass Spectrometry and Tandem Mass Spectrometry for Peptide de Novo Amino Acid Sequencing for a Seven-Protein Mixture by Paired Single-Residue Transposed Lys-N and Lys-C Digestion</i>	<b>Rapid Communications in Mass Spectrometry</b>	31	-	207-217	10.1002/rcm.7783
	Ligiero, L.M.; Dicharry, C.; Passade-Boupat, N.; Bouysiere, B.; Lalli, P.M.; Rodgers, R.P.; Barrère-Mangote, C.; Giusti, P. and Bouriat, P.,	<i>Characterization of Crude Oil Interfacial Material Isolated by the Wet Silica Method. Part 2: Dilatational and Shear Interfacial Properties</i>	<b>Energy &amp; Fuels</b>	31	2	1072-1081	10.1021/acs.energyfuels.6b02897
	Ligiero, L.M.; Bouriat, P.; Dicharry, C.; Passade-Boupat, N.; Lalli, P.M.; Rodgers, R.P.; Barrère-Mangote, C.; Giusti, P. and Bouysiere, B.,	<i>Characterization of Crude Oil Interfacial Material Isolated by the Wet Silica Method. Part 1 @ Gel Permeation Chromatography Inductively Coupled Plasma High Resolution Mass Spectrometry Analysis</i>	<b>Energy &amp; Fuels</b>	31	2	1065-1071	10.1021/acs.energyfuels.6b02899
	Ajaero, C.; McMartin, D.W.; Peru, K.M.; Bailey, J.; Haakensen, M.; Friesen, V.; Martz, R.; Hughes, S.A.; Brown, C.; Chen, H.; McKenna, A.M., Corilo, Y.E. and Headley, J.V.,	<i>Fourier Transform Ion Cyclotron Resonance Mass Spectrometry Characterization of Athabasca Oil Sand Process-Affected Waters Incubated in the Presence of Wetland Plants</i>	<b>Energy &amp; Fuels</b>	31	2	1731-1740	10.1021/acs.energyfuels.6b02643
	Krajewski, L.C.; Lobodin, V.V.; Robbins, W.K.; Jin, P.; Bota, G.; Marshall, A.G. and Rodgers, R.P.,	<i>Method for Isolation and Detection of Ketones Formed from High-Temperature Naphthenic Acid Corrosion</i>	<b>Energy &amp; Fuels</b>	31	10	10674-10679	10.1021/acs.energyfuels.7b01803
	Harris, T.; dos Passos Gomes, G.; Ayad, S.; Clark, R.J.; Lobodin, V.V.; Tuscan, M.; Hanson, K. and Alabugin, I.V.,	<i>Twisted Cycloalkynes and Remote Activation of Click Reactivity</i>	<b>Chem</b>	3	4	629-640	10.1016/j.chempr.2017.07.011

## 6.6. NMR Facility at FSU

Cites NSF Core Grant	Authors	Title	Journal Name	Vol	Issue	Pages	DOI
X	Abad, N.; Rosenberg, J.T.; Roussel, T.; Grice, D.C.; Harrington, M.G. and Grant, S.C.,	<i>Metabolic Assessment of a Migraine Model Using Relaxation-Enhanced 1H Spectroscopy at Ultrahigh Field</i>	<b>Magnetic Resonance in Medicine</b>	79	3	1266-1275	10.1002/mrm.26811
X	Abhyankar, N.; Kweon, J.J.; Orio, M.; Bertaina, S.; Lee, M.; Choi, E.S.; Fu, R. and Dalal, N.S.,	<i>Understanding Ferroelectricity in the Pb-Free Perovskite-Like Metal-Organic Framework [(CH3)2NH2]Zn(HCOO)3: Dielectric, 2D NMR, and Theoretical Studies</i>	<b>Journal of Physical Chemistry C</b>	121	11	6314-6322	10.1021/acs.jpcc.7b00596
X	Brown, C.; Lita, A.; Tao, Y.; Peek, N.; Crosswhite, M.; Mileham, M.; Krzystek, J.; Achey, R.; Fu, R.; Bindra, J.K.; Polinski, M.; Wang, Y.;	<i>Mechanism of initiation in the Phillips ethylene polymerization catalyst: ethylene activation by Cr(II) and the structure of the resulting active site</i>	<b>American Chemical Society Catalysis</b>	7	-	7442-7455	10.1021/acscatal.7b02677

# Chapter 6 – Accomplishments & Discoveries

Cites NSF Core Grant	Authors	Title	Journal Name	Vol	Issue	Pages	DOI
	van de Burgt, L.J.; Jeffcoat, D.; Profeta, Jr., S.; Stieglman, A.E. and Scott; S.L.,						
X	Cui, J.; Li, J.; Peng, X.H. and Fu, R.,	<i>Transient NOE Enhancement in Solid-State MAS NMR of Mobile Systems</i>	<b>Journal of Magnetic Resonance</b>	284	-	73-79	10.1016/j.jmr.2017.09.011
X	DeHaven, B.A.; Tokarski, J.T., III.; Korous, A.A.; Mentink-Vigier, F.; Makris, T.M.; Brugh, A.M.; Forbes, M.D.E.; van Tol, J.; Bowers, C.R. and Shimizu, L.S.,	<i>Persistent Radicals of Self-assembled Benzophenone bis-urea Macrocycles: Characterization and Application as a Polarizing Agent for Solid-state DNP MAS Spectroscopy</i>	<b>Chemistry a European Journal</b>	23	-	1-6	10.1002/chem.201701705
X	Dutta, A.R.; Sekar, P.; Dvovashkin, M.; Bowers, C.; Ziegler, K.J. and Vasenkov, S.,	<i>Possible role of molecular clustering in single-file diffusion of mixed and pure gases in dipeptide nanochannels</i>	<b>Microporous and Mesoporous Media</b>	early view	-	1-5	10.1016/j.micromeso.2017.05.025
X	Feng, X.-Y.; Li, X.; Tang, M.; Gan, A. and Hu, Y.-Y.,	<i>Enhanced rate performance of Li4Ti5O12 anodes with bridged grain boundaries</i>	<b>Journal of Power Sources</b>	354	-	172-178	10.1016/j.jpowsour.2017.04.032
X	Gan, Z.; Hung, I.; Wang, X.L.; Paulino, J.; Wu, G.; Litvak, I.M.; Gor'kov, P.L.; Brey, W.W.; Lendi, P.; Schiano, J.L.; Bird, M.D.; Dixon, L.R.; Toth, J.; Boebinger, G.S. and Cross, T.A.,	<i>NMR spectroscopy up to 35.2 T using a series-connected hybrid magnet</i>	<b>Journal of Magnetic Resonance</b>	284	-	125-136	10.1016/j.jmr.2017.08.007
X	Ge, Y.W.; Hung, I.; Liu, X.L.; Liu, M.L.; Gan, Z. and Li, C.G.,	<i>Measurement of amide proton chemical shift anisotropy in perdeuterated proteins using CSA amplification</i>	<b>Journal of Magnetic Resonance</b>	284	-	33-38	10.1016/j.jmr.2017.09.009
X	George, N.C.; Brgoch, J.; Pell, A.J.; Cozzan, C.; Jaffe, A.; Dantelle, G.; Llobet, A.; Pintacuda, G.; Seshadri, R. and Chmelka, B.F.,	<i>Correlating Local Compositions and Structures with the Macroscopic Optical Properties of Ce3+-Doped CaSc2O4, an Efficient Green-Emitting Phosphor</i>	<b>Chemistry of Materials</b>	29	-	3538-3546	10.1021/acs.chemmater.6b05394
X	Hung, I.; Wu, G. and Gan, Z.,	<i>Second-order quadrupolar line shapes under molecular dynamics: An additional transition in the extremely fast regime</i>	<b>Solid State Nuclear Magnetic Resonance</b>	84	-	14-19	10.1016/j.ssnmr.2016.11.002
X	Jakobsen, H.J.; Lindhardt, A.T.; Bildsoe, H.; Skibsted, J.; Gan, Z.; Hung, I. and Larsen, F.H.,	<i>Dynamic Solid-State NMR Experiments Reveal Structural Changes for a Methyl Silicate Nanostructure on Deuterium Substitution</i>	<b>Journal of Physical Chemistry C</b>	121	47	26507-26518	10.1021/acs.jpcc.7b08826
X	Jeon, J.; Qiao, X.; Hung, I.; Mitra, A.K.; Desfosses, A.; Huang, D.; Gor'kov, P.L.; Craven, R.C.; Kingston, R.L.; Gan, Z.; Zhu, F. and Chen, B.,	<i>Structural Model of the Tubular Assembly of the Rous Sarcoma Virus Capsid Protein.</i>	<b>Journal of the American Chemical Society</b>	139	5	2006-2013	10.1021/jacs.6b11939
X	Keeler, E.G.; Michaelis, V.K.; Colvin, M.T.; Hung, I.; Gor'kov, P.L.; Cross, T.A.; Gan, Z. and Griffin, R.G.,	<i>17O MAS NMR Correlation Spectroscopy at High Magnetic Fields</i>	<b>J. Am. Chem. Soc</b>	139	-	17953-17963	10.1021/jacs.7b08989

# Chapter 6 – Accomplishments & Discoveries

Cites NSF Core Grant	Authors	Title	Journal Name	Vol	Issue	Pages	DOI
X	Kweon, J.J.; Fu, R.; Choi, E.S. and Dalal, N.S.,	<i>Magic angle spinning NMR study of the ferroelectric transition of KH<sub>2</sub>PO<sub>4</sub>: definitive evidence of a displacive component</i>	<b>Journal of Physics-Condensed Matter</b>	29	-	16LT01	10.1088/1361-648X/aa638a
X	Li, X.; Tang, M.X.; Feng, X.Y.; Hung, I.; Rose, A.; Chien, P.H.; Gan, Z. and Hu, Y.Y.,	<i>Lithiation and Delithiation Dynamics of Different Li Sites in Li-Rich Battery Cathodes Studied by Operando Nuclear Magnetic Resonance</i>	<b>Chemistry of Materials</b>	29	19	8282-8291	10.1021/acs.chemmater.7b02589
X	Libardo, M.D.J.; Bahar, A.A.; Fu, R.; McCormick, L.E.; Jun Zhao, J.; McCallum, S.A.; Nussinov, R.; Ren, D.C.; Angeles-Boza, A.M. and Cotten, M.L.,	<i>Nuclease activity gives an edge to host-defense peptide piscidin 3 over piscidin 1, rendering it more effective against persisters and biofilms</i>	<b>The FEBS Journal</b>	284	21	3662-3683	10.1111/febs.14263
X	Lim, K.H.; Dasari, A.K.R.; Ma, R.; Hung, I.; Gan, Z.; Kelly, J.W. and Fitzgerald, M.C.,	<i>Pathogenic Mutations Induce Partial Structural Changes in the Native <math>\beta</math>-Sheet Structure of Transthyretin and Accelerate Aggregation</i>	<b>Biochemistry</b>	56	36	4808-4818	10.1021/acs.biochem.7b00658
X	Lu, J.; Hung, I.; Brinkmann, A.; Gan, Z.; Kong, X. and Wu, G.,	<i>Solid-State <sup>17</sup>O NMR Reveals Hydrogen-Bonding Energetics: Not All Low-Barrier Hydrogen Bonds Are Strong</i>	<b>Angewandte Chemie International Edition</b>	56	22	6166-6170	10.1002/ange.201700488
X	Marple, M.; Badger, J.; Hung, I.; Gan, Z.; Kovnir, K. and Sen, S.,	<i>Structure of Amorphous Selenium by 2D Se-77 NMR Spectroscopy: An End to the Dilemma of Chain versus Ring</i>	<b>Angewandte Chemie International Edition</b>	56	33	9777-9781	10.1002/anie.201704323
X	Marple, M.A.T.; Hung, I.; Gan, Z. and Sen, S.,	<i>Structural and Topological Evolution in SixSe<sub>1-x</sub> Glasses: Results from 1D and 2D Si-29 and Se-77 NMR Spectroscopy</i>	<b>Journal of Physical Chemistry B</b>	121	16	4283-4292	10.1021/acs.jpcc.7b01307
X	Muche, D.N.F.; Marple, M.A.T.; Hung, I.; Gan, Z.; Castro, R.H.R. and Sen, S.,	<i>Size-Induced Structural Disorder Enables Ultrahard Oxides</i>	<b>Journal of Physical Chemistry C</b>	121	25	13898-13905	10.1021/acs.jpcc.7b03323
X	Murray, D.T.; Kato, M.; Lin, Y.; Thurber, K.R.; Hung, I.; McKnight, S.L. and Tycko, R.,	<i>Structure of FUS Protein Fibrils and Its Relevance to Self-Assembly and Phase Separation of Low-Complexity Domains</i>	<b>Cell</b>	171	3	615-627	10.1016/j.cell.2017.08.048
X	Ngatia, L.W.; Hsieh, Y.P.; Nemours, D.; Fu, R. and Taylor, R.W.,	<i>Potential phosphorus eutrophication mitigation strategy: Biochar carbon composition, thermal stability and pH influence phosphorus sorption</i>	<b>Chemosphere</b>	180	-	201-211	10.1016/j.chemosphere.2017.04.012
X	Qin, H.; Miao, Y.; Cross, T.A. and Fu, R.,	<i>Beyond Structural Biology to Functional Biology: Solid-State NMR Experiments and Strategies for Understanding the M2 Proton Channel Conductance.</i>	<b>Journal of Physical Chemistry B</b>	121	18	4799-4809	10.1021/acs.jpcc.7b02468
X	Rosenberg, J.T.; Shemesh, N.; Muniz, J.A.; Dumez, J.N.; Frydman, L. and Grant, S.C.,	<i>Transverse relaxation of selectively excited metabolites in stroke at 21.1 T.</i>	<b>Magnetic Resonance in Medicine</b>	77	2	520-528	10.1002/mrm.26132
X	Sadleir, R.J.; Fu, F.; Falgas, C.; Holland, S.; Boggess, M.; Grant, S.C. and Woo, E.J.,	<i>Direct detection of neural activity in vitro using magnetic resonance electrical impedance tomography (MREIT)</i>	<b>NeuroImage</b>	161	-	104-119	10.1016/j.neuroimage.2017.08.004



# Chapter 6 – Accomplishments & Discoveries

Cites NSF Core Grant	Authors	Title	Journal Name	Vol	Issue	Pages	DOI
X	Schepkin, V.D.; Neubauer, A.; Nagel, A.M. and Budinger, T.F.,	<i>Comparison of potassium and sodium binding in vivo and in agarose samples using TQTPPI pulse sequence</i>	<b>Journal of Magnetic Resonance</b>	277	-	162-168	10.1016/j.jmr.2017.03.003
X	Shemesh, N.; Rosenberg, J.T.; Dumez, J-N.; Grant, S.C. and Frydman, L.,	<i>Distinguishing neuronal from astrocytic subcellular microstructures using in vivo Double Diffusion Encoded 1H MRS at 21.1 T</i>	<b>PLoS ONE</b>	12	10	1-19	10.1371/journal.pone.0185232
X	Theint, T.; Nadaud, P.S.; Aucoin, D.; Helmus, J.J.; Pondaven, S.P.; Surewicz, K.; Surewicz, W.K. and Jaroniec, C.P.,	<i>Species-Dependent Structural Polymorphism of Y145Stop Prion Protein Amyloid Revealed by Solid-State NMR Spectroscopy</i>	<b>Nature Communications</b>	8	-	753	10.1038/s41467-017-00794-z
X	Tzitzoglaki, C.; Wright, A.; Freudenberger, K.; Hoffmann, A.; Tietjen, I.; Stylianakis, I.; Kolarov, F.; Fedida, D.; Schmidtke, M.; Gauglitz, G.; Cross, T.A. and Kolocouris, A.,	<i>Binding and Proton Blockage by Amantadine Variants of the Influenza M2WT and M2S31N Explained.</i>	<b>Journal of Medicinal Chemistry</b>	60	5	1716-1733	10.1021/acs.jmedchem.6b01115
X	Vugmeyster, L. and Ostrovsky, D.,	<i>Comparative Dynamics of Methionine Side-Chain in Fmoc-Methionine and in Amyloid Fibrils</i>	<b>Chemical Physics Letters</b>	67	-	108-112	10.1016/j.cpl.2017.02.021
X	Vugmeyster, L.; Hagedorn, B.; Clark, A.M. and Sletten, R.S.,	<i>Evaluating the Effect of Grain Size and Salts on Liquid Water Content in Frozen Soils of Antarctica by Combining NMR, Chemical Equilibrium Modeling, and Scattered Diffraction Analysis.</i>	<b>Geoderma</b>	299	-	25-31	10.1016/j.geoderma.2017.03.024
X	Vugmeyster, L.; Ostrovsky, D.; Hoatson, G.L.; Qiang, W. and Falconer, I.B.,	<i>Solvent-Driven Dynamical Crossover in the Phenylalanine Side-Chain from the Hydrophobic Core of Amyloid Fibrils Detected by 2H NMR Relaxation</i>	<b>Journal of Physical Chemistry B</b>	121	-	7267-7275	10.1021/acs.jpcc.7b04726
X	Wi, S.; Schurko, R.; Frydman, L.,	<i>1H-2H cross-polarization NMR in fast spinning solids by adiabatic sweeps</i>	<b>Journal of Chemical Physics</b>	146	10	104201	10.1063/1.4976980
X	Yang, T.; Zheng, J.; Cheng, Q.; Hu, Y.Y. and Chan, C.K.,	<i>Composite Polymer Electrolytes with Li7La3Zr2O12 Garnet-Type Nanowires as Ceramic Fillers: Mechanism of Conductivity Enhancement and Role of Doping and Morphology.</i>	<b>American Chemical Society Applied Materials and Interfaces</b>	9	26	21773-21780	10.1021/acsmaterials.7b03806
X	Zheng, J.; Dang, H.; Feng, X.; Chien, P.-H. and Hu, Y.-Y.,	<i>Li-Ion Transport in a Representative Ceramic/polymer/plasticizer Composite Electrolyte: Li7La3Zr2O12/polyethylene Oxide/tetraethylene Glycol Dimethyl Ether</i>	<b>Journal of Materials Chemistry A</b>	5	35	18457-18463	10.1039/C7TA05832B
X	Zhou, C.; Tian, Y.; Wang, M.; Rose, A.; Besara, T.; Doyle, N.K.; Yuan, Z.; Wang, J.C.; Clark, R.; Hu, Y.; Siegrist T., Lin S. and Ma B.,	<i>Low-Dimensional Organic Tin Bromide Perovskites and Their Photoinduced Structural Transformation</i>	<b>Angewandte Chemie International Edition</b>	56	31	9018-9022	10.1002/anie.201702825
	Affram, K.; Udofot, O.; Singh, M.; Krishnan, S.; Reams, R.; Rosenberg,	<i>Smart thermosensitive liposomes for effective solid tumor therapy and in vivo imaging</i>	<b>PLoS ONE</b>	12	9	22	10.1371/journal.pone.0185116

# Chapter 6 – Accomplishments & Discoveries

Cites NSF Core Grant	Authors	Title	Journal Name	Vol	Issue	Pages	DOI
	J.T. and Agyare, E., Dossat, A.M.; Sanchez-Gonzalez, M.A.; Koutnik, A.P.; Leitner, S.; Ruiz, E.L.; Griffin, B.; Rosenberg, J.T.; Grant, S.C.; Fincham, F.D.; Pinto, J.R. and Kabbaj, M.,	<i>Pathogenesis of depression- and anxiety-like behavior in an animal model of hypertrophic cardiomyopathy.</i>	<b>The FASEB Journal</b>	31	6	2492-2506	10.1096/fj.20160955R
	Holliday, M.J.; Camilloni, C.; Armstrong, G.S.; Vendruscolo, M. and Eisenmesser, E.Z.,	<i>Networks of Dynamic Allostery Regulate Enzyme Function</i>	<b>Structure</b>	25	2	276-286	10.1016/j.str.2016.12.003
	Koroloff, S.N. and Nevzorov, A.A.,	<i>Selective Excitation for Spectral Editing and Assignment in Separated Local Field Experiments of Oriented Membrane Proteins</i>	<b>Journal of Magnetic Resonance</b>	274	-	7-12	10.1016/j.jmr.2016.10.013
	Liu, B.; Rose, A.; Zhang, N.; Hu, Y.-Y. and Ma, M.,	<i>Efficient Co-Nanocrystal-Based Catalyst for Hydrogen Generation from Borohydride</i>	<b>Journal of Physical Chemistry C</b>	121	23	12610-12616	10.1021/acs.jpcc.7b03094
	Liu, R.; Xu, G.L.; Li, Q.; Zheng, S.Y.; Zheng, G.R.; Gong, Z.L.; Li, Y.X.; Kruskop, E.; Fu, R.; Chen, Z.H.; Amine, K. and Yang, Y.,	<i>Exploring Highly Reversible 1.5-Electron Reactions (V<sup>3+</sup>/V<sup>4+</sup>/V<sup>5+</sup>) in Na<sub>3</sub>VCr(PO<sub>4</sub>)<sub>3</sub> Cathode for Sodium-Ion Batteries</i>	<b>American Chemical Society Applied Materials and Interfaces</b>	9	50	43632-43639	10.1021/acsaami.7b13018
	Mentink-Vigier, F.; Mathies, G.; Liu, Y.; Barra, A.-L.; Caporini, M.; Lee, D.; Hediger, S.; Griffin, R.G. and De Paëpe, G.,	<i>Efficient Cross-Effect Dynamic Nuclear Polarization without Depolarization in High-resolution MAS NMR</i>	<b>Chemical Science</b>	8	-	8150-8163	10.1039/C7SC02199B
	Neubauer, A.; Nies, C.; Schepkin, V.D.; Hu, R.; Malzacher, M.; Chacon-Caldera, J.; Thiele, D.; Gottwald, E. and Schad, L.R.,	<i>Tracking protein function with sodium multi quantum spectroscopy in a 3D-tissue culture based on microcavity arrays</i>	<b>Scientific Reports</b>	7	3943	1-9	10.1038/s41598-017-04226-2
	Ramaswamy, V.; Brey, W.W. and Edison, A.S.,	<i>Inductively-Coupled Frequency Tuning and Impedance Matching in HTS-Based NMR Probes</i>	<b>IEEE Transactions on Applied Superconductivity</b>	27	4	1-5	10.1109/TASC.2017.2672718
	Wi, S.; Kim, C.; Schurko, R. and Frydman, L.,	<i>Adiabatic sweep cross-polarization magic-angle-spinning NMR of half-integer quadrupolar spins</i>	<b>Journal of Magnetic Resonance</b>	277	-	131	10.1016/j.jmr.2017.02.021
	Zhao, E.W.; Maligal-Ganesh, R.; Xiao, C.; Goh, T.-W.; Qi, Z.; Pei, Y.; Hagelein-Weaver, H. E.; Huang, W. and Bowers, C.R.,	<i>Silica-Encapsulated Pt-Sn Intermetallic Nanoparticles: A Robust Catalytic Platform for Parahydrogen-Induced Polarization of Gases and Liquids</i>	<b>Angewandte Chemie International Edition</b>	56	-	3925-3929	10.1002/anie.201701314

## 6.7. Pulsed Field Facility at LANL

Cites NSF Core Grant	Authors	Title	Journal Name	Vol	Issue	Pages	DOI
X	Alberi, K.; Christian, T.M.; Fluegel, B.; Crooker, S.A.; Beaton, D.A. and Mascarenhas, A.,	<i>Localization behavior at bound Bi complex states in GaAs<sub>1-x</sub>Bix</i>	<b>Physical Review Materials</b>	1	-	24605	10.1103/PhysRevMaterials.1.024605

# Chapter 6 – Accomplishments & Discoveries

Cites NSF Core Grant	Authors	Title	Journal Name	Vol	Issue	Pages	DOI
X	Brambleby, J.; Goddard, P.A.; Singleton, J.; Jaime, M.; Lancaster, T.; Huang, L.; Wosnitzer, J.; Topping, C.V.; Carreiro, K.E.; Tran, H.E.; Manson, Z.E. and Manson, J.L.,	<i>Adiabatic Physics of an Exchange-coupled Spin-dimer System: Magnetocaloric Effect, Zero-point Fluctuations, and Possible Two-dimensional Universal Behavior</i>	<b>Physical Review B</b>	95	2	24404	10.1103/PhysRevB.95.024404
X	Brambleby, J.; Manson, J.L.; Goddard, P.A.; Stone, M.B.; Johnson, R.D.; Manuel, P.; Villa, J.A.; Brown, C.M.; Lu, H.; Chikara, S.; Zapf, V.; Lapidus, S.H.; Scatena, R.; Macchi, P.; Chen, Y.-S.; Wu, L.-C. and Singleton, J.,	<i>Combining microscopic and macroscopic probes to untangle the single-ion anisotropy and exchange energies in an S = 1 quantum antiferromagnet</i>	<b>Physical Review B</b>	95	-	134435	10.1103/PhysRevB.95.134435
X	Bulmer, J.S.; Lekawa-Raus, A.; Rickel, D.G.; Balakirev, F.F. and Koziol, K.K.,	<i>Extreme Magneto-transport of Bulk Carbon Nanotubes in Sorted Electronic Concentrations and Aligned High Performance Fiber</i>	<b>Scientific Report</b>	7	-	12193	10.1038/s41598-017-12546-6
X	Chikara, S.; Fabbris, G.; Terzic, J.; Cao, G.; Khomskii, D. and Haskel, D.,	<i>Charge partitioning and anomalous hole doping in Rh-doped Sr2IrO4</i>	<b>Physical Review B Rapid Communications</b>	95	6	60407	10.1103/PhysRevB.95.060407
X	Clune, A.J.; Hughey, K.D.; Lee, C.; Abhyankar, N.; Ding, X.; Dalal, N.S.; Whangbo, M.-H.; Singleton, J. and Musfeldt, J.L.,	<i>Magnetic field-temperature phase diagram of multiferroic [(CH3)2NH2]Mn(HCOO)3</i>	<b>Physical Review B</b>	96	-	104424	10.1103/PhysRevB.96.104424
X	Dey, P.; Yang, L.; Robert, C.; Wang, G.; Urbaszek, B.; Marie, X. and Crooker, S.A.,	<i>Gate-Controlled Spin-Valley Locking of Resident Carriers in WSe2 Monolayers</i>	<b>Physical Review Letters</b>	119	-	137401	10.1103/PhysRevLett.119.137401
X	Grinenko, V.; Iida, K.; Kurth, F.; Efremov, D.V.; Drechsler, S.-L.; Cherniavskii, I.; Morozov, I.; Hänisch, J.; Förster, T.; Tarantini, C.; Jaroszynski, J.; Maiorov, B.; Jaime, M.; Yamamoto, A.; Nakamura, I.; Fujimoto, R.; Hatano, T.; Ikuta, H. and Hühne, R.,	<i>Selective mass enhancement close to the quantum critical point in BaFe2(As1-xPx)2</i>	<b>Nature Scientific Reports</b>	7	-	4589	10.1038/s41598-017-04724-3
X	Hoch, M.J.R.,	<i>Spin clusters and low energy excitations in rare earth kagome systems</i>	<b>Modern Physics Letters B</b>	31	1	163001	10.1142/S0217984916300106
X	Jaime, M.; Corvalán Moya, C.; Weickert, F.; Zapf, V.; Balakirev, F.F.; Wartenbe, M.; Rosa, P.F.S.; Betts, J.B.; Rodriguez, G.; Crooker, S.A. and Daou, R.,	<i>Fiber Bragg Grating Dilatometry in Extreme Magnetic Field and Cryogenic Conditions</i>	<b>Sensors</b>	17	11	2572	10.3390/s17112572
X	Jaime, M.; Saul, A.; Salamon, M.; Zapf, V.S.; Harrison, N.; Durakiewicz, T.; Lashley, J.C.; Andersson, D.A.; Stanek, C.R.; Smith, J.L. and Gofryk, K.,	<i>Piezomagnetism and magnetoelastic memory in uranium dioxide</i>	<b>Nature Communications</b>	8	-	99	10.1038/s41467-017-00096-4

# Chapter 6 – Accomplishments & Discoveries

Cites NSF Core Grant	Authors	Title	Journal Name	Vol	Issue	Pages	DOI
X	Kasahara, Y.; Takeuchi, Y.; Zadik, R.H.; Takabayashi, Y.; Colman, R.H.; McDonald, R.D.; Rosseinsky, M.J.; Prasad, K. and Iwasa, Y.,	<i>Upper critical field reaches 90 Tesla near the Mott transition in fulleride superconductors</i>	<b>Nature Communica- tions</b>	8	-	14467	10.1038/nco mms14467
X	Lee, J.A.; Xin, Y.; Stolt, I.; Halperin, W.P.; Reyes, A.P.; Kuhns, P.L. and Chan, M.K.,	<i>Coherent Charge and Spin-Density Waves in Underdoped HgBa<sub>2</sub>CuO<sub>4</sub>+<math>\delta</math></i>	<b>New Journal of Physics</b>	19	-	33024	10.1088/1367 -2630/aa6277
X	Modic, K.A.; Ramshaw, B.J.; Breznay, N.P.; Analytis, J.G.; Betts, J.B.; McDonald, R.D. and Shehter, A.,	<i>Robust spin correlations at high magnetic fields in the honeycomb iridates,</i>	<b>Nature Communica- tions</b>	8	-	180	10.1038/s414 67-017- 00264-6
X	Moll, P.J.W.; Helm, T.; Zhang, S.S.; Batista, C.D.; Harrison, N.; McDonald, R.D.; Winter, L.E.; Ramshaw, B.J.; Chan, M.K.; Balakirev, F.F.; Batlogg, B.; Bauer, E.D. and Ronning, F.,	<i>Emergent magnetic anisotropy in the cubic heavy-fermion metal CeIn<sub>3</sub></i>	<b>Nature Quantum Materials</b>	2	-	46	10.1038/s415 35-017-0052- 5
X	Nikolo, M.; Singleton, J.; Solenov, D.; Jiang, J.; Weiss, J.D. and Hellstrom, E.E.,	<i>Upper Critical and Irreversibility Fields in Ba(Fe<sub>0.92</sub>Co<sub>0.08</sub>)<sub>2</sub>As<sub>2</sub> and Ba(Fe<sub>0.91</sub>Co<sub>0.09</sub>)<sub>2</sub>As<sub>2</sub> Pnictide Bulk Superconductors</i>	<b>Journal of Super- conductivity and Novel Magnetism</b>	30	-	561- 568	10.1007/s109 48-016-3727- 4
X	Nikolo, M.; Singleton, J.; Solenov, D.; Jiang, J.; Weiss, J.D. and Hellstrom, E.E.,	<i>Upper critical and irreversibility fields in Ba(Fe<sub>0.95</sub>Ni<sub>0.05</sub>)<sub>2</sub>As<sub>2</sub> and Ba(Fe<sub>0.94</sub>Ni<sub>0.06</sub>)<sub>2</sub>As<sub>2</sub> pnictide bulk superconductors</i>	<b>Journal of Super- conductivity and Novel Magnetism</b>	30	-	331- 341	10.1007/s109 48-016-3726- 5
X	Rice, W.D.; Liu, W.; Pinchetti, V.; Yakovlev, D.R.; Klimov, V.I. and Crooker, S.A.,	<i>Direct Measurements of Magnetic Polarons in CdMnSe Nanocrystals from Resonant Photoluminescence</i>	<b>Nano Letters</b>	17	-	3068	10.1021/acs.n anolett.7b004 21
X	Ronning, F.; Helm, T.; Shirer, K.; Bachmann, M.; Balicas, L.; Chan, M.; Ramshaw, B.; McDonald, R.; Balakirev, F.; Bauer, E.; Jaime, M. and Moll, P.,	<i>Electronic in-plane symmetry breaking at field-tuned quantum criticality in CeRhIn<sub>5</sub></i>	<b>Nature</b>	548	-	313- 317	10.1038/natu re23315
X	Rosa, P.F.S.; Thomas, S.M.; Balakirev, F.F.; Betts, J.; Seo, S.; Bauer, E.D.; Thompson, J.D. and Jaime, M.,	<i>An FBG Optical Approach to Thermal Expansion Measurements under Hydrostatic Pressure</i>	<b>Sensors</b>	17	11	2543	10.3390/s171 12543
X	Schulze Grachtrup, D.; Steinki, N.; Süllow, S.; Cakir, Z.; Zwicknagl, G.; Krupko, Y.; Sheikin, I.; Jaime, M. and Mydosh, J.A.,	<i>Magnetic phase diagram and electronic structure of UPt<sub>2</sub>Si<sub>2</sub> at high magnetic fields: A possible field-induced Lifshitz transition</i>	<b>Physical Review B</b>	95	-	134422	10.1103/Phys RevB.95.1344 22
X	Shehter, A.; Modic, K.A.; McDonald, R.D. and Ramshaw B.J.,	<i>Thermodynamic constraints on the amplitude of quantum oscillations</i>	<b>Physical Review B Rapid Communica- tions</b>	95	-	121106	10.1103/Phys RevB.95.1211 06
X	Shin, D.; Lee, Y.; Sasaki, M.; Jeong, H.L.; Weickert, F.; Betts, J.B.; Kim, H.-J.; Kim, K.S. and Kim, J.,	<i>Violation of Ohm's law in a Weyl metal</i>	<b>Nature Materials</b>	16	-	1096- 1199	10.1038/nma t4965

# Chapter 6 – Accomplishments & Discoveries

Cites NSF Core Grant	Authors	Title	Journal Name	Vol	Issue	Pages	DOI
X	Shrestha, K.; Antonio, D.; Jaime, M.; Harrison, N.; Mast, D.S.; Safarik, D.; Durakiewicz, T.; Griveau, J.-C. and Gofryk, K.,	<i>Tricritical point from high-field magnetoelastic and metamagnetic effects in UN</i>	<b>Scientific Report</b>	7	-	6642	10.1038/s41598-017-06154-7
X	Stillwell, R.L.; Liu, I.-L.; Harrison, N.; Jaime, M.; Jaffries, J.R. and Butch, N.P.,	<i>Tricritical point of the f-electron antiferromagnet USb<sub>2</sub> driven by high magnetic fields</i>	<b>Physical Review B</b>	95	-	14414	10.1103/PhysRevB.95.014414
X	Wartenbe, M.R.; Chen, K.W.; Gallagher, A.; Harrison, N.; McDonald, R.D.; Boebinger, G.S. and Baumbach, R.E.,	<i>Role of band filling in tuning the high-field phases of URu<sub>2</sub>Si<sub>2</sub></i>	<b>Physical Review B</b>	96	-	85141	10.1103/PhysRevB.96.085141
X	Weickert, D.F.; Civale, L.; Maiorov, B.; Jaime, M.; Salamon, M.B.; Carleschi, E.; Strydom, A. M.; Fittipaldi, R.; Granata, V. and Vecchione, A.,	<i>In-depth study of the H-T phase diagram of Sr<sub>3</sub>Ru<sub>4</sub>O<sub>10</sub> by magnetization experiments</i>	<b>Physica B. Condensed Matter</b>	9	-	106	10.1016/j.physb.2017.09.106
X	Weickert, D.F.; Civale, L.; Maiorov, B.; Jaime, M.; Salamon, M.B.; Carleschi, E.; Strydom, A.M.; Fittipaldi, R.; Granata, V. and Vecchione, A.,	<i>Missing magnetism in Sr<sub>4</sub>Ru<sub>3</sub>O<sub>10</sub>: Indication for Antisymmetric Exchange Interaction</i>	<b>Nature Scientific Reports</b>	7	-	3867	10.1038/s41598-017-03648-2
X	Wolgast, S.; Eo, Y.S.; Sun, K.; Kurdak, C.; Balakirev, F.F.; Jaime, M.; Kim, D.-J. and Fisk Z.,	<i>Reduction of the low-temperature bulk gap in samarium hexaboride under high magnetic fields</i>	<b>Physical Review B</b>	95	-	245112	10.1103/PhysRevB.95.245112
X	Xia, J.S.; Yin, L.; Sullivan, N.S.; Zapf, V.S. and Paduan-Filho, A.,	<i>Magneto-electric Effect and Dielectric Susceptibility Measurement Technique at Very Low Temperature</i>	<b>Journal of Low Temperature Physics</b>	187	-	627	10.1007/s10909-016-1723-5
X	Zhu, Z.; Wang, J.; Zuo, H.; Fauque, B.; McDonald, R.D.; Fuseya, Y. and Behnia, K.,	<i>Emptying Dirac Valleys in Bismuth Using High Magnetic Fields</i>	<b>Nature Communications</b>	8	-	15297	10.1038/ncomms15297
X	Zybert, M.; Marchewka, M.; Sheregii, E.M.; Rickel, D.G.; Betts, J.B.; Balakirev, F.F.; Gordon, M.; Stier, A.V.; Mielke, C.H.; Pfeffer, P. and Zawadzki, W.,	<i>Landau levels and shallow donor states in GaAs/AlGaAs multiple quantum wells at megagauss magnetic fields</i>	<b>Physical Review B</b>	95	11	115432	10.1103/PhysRevB.95.115432
	Azad, A.K.; Efimov, A.V.; Ghosh, S.; Singleton, J.; Taylor, A.J. and Chen, H.,	<i>Ultra-thin metasurface microwave flat lens for broadband applications</i>	<b>Applied Physics Letters</b>	110	-	224101	10.1063/1.4984219
	Eley, S.; Miura, M.; Maiorov, B. and Civale, L.,	<i>Universal lower limit on vortex creep in superconductors</i>	<b>Nature Materials</b>	16	-	409	10.1038/NMAT4840
	Grosberg, A.Y.; Halperin, B. and Singleton, J.,	<i>In celebration of Ilya Lifshitz</i>	<b>Physics Today</b>	70	-	44	10.1063/PT.3.3764
	Jiao, L.; Weng, Z.F.; Smidman, M.; Graf, D.; Singleton, J.; Bauer, E.D.; Thompson, J.D. and Yuan, H.Q.,	<i>Magnetic field-induced Fermi surface reconstruction and quantum criticality in CeRhIn<sub>5</sub></i>	<b>Philosophical Magazine A - Physics of Condensed Matter Structure Defects and Mechanical Properties</b>	97	36	1-10	10.1080/14786435.2017.1282181

# Chapter 6 – Accomplishments & Discoveries

Cites NSF Core Grant	Authors	Title	Journal Name	Vol	Issue	Pages	DOI
	Kim, D.Y.; Lin, S.-Z.; Weickert, F.; Bauer, E.D.; Ronning, F.; Thompson, J. D. and Movshovich, R.,	<i>Resonances in the Field-Angle-Resolved Thermal Conductivity of CeCoIn5</i>	<b>Physical Review Letters</b>	118	-	197001	10.1103/PhysRevLett.118.197001
	Maiorov, B.; Betts, J.B.; Soderlind, P.; Landa, A.; Hernandez, S.C.; Saleh, T.A.; Freibert, F.J. and Migliori, A.,	<i>Elastic moduli of delta-Pu-239 reveal aging in real time</i>	<b>Journal of Applied Physics</b>	121	12	0	10.1063/1.4978509
	Migliori, A.; Soderlind, P.; Landa, A.; Freibert, F.J.; Maiorov, B.; Ramshaw, B.J. and Betts, J.B.,	<i>The excited delta-phase of plutonium</i>	<b>Proceedings of the National Academy of Sciences of the United States of America</b>	114	3	E269	10.1073/pnas.1619207114
	Miura, M.; Maiorov, B.; Sato, M.; Kanai, M.; Kato, T.; Kato, T.; Izumi, T.; Awaji, S.; Mele, P.; Kiuchi, M. and Matsushita, T.,	<i>Tuning nanoparticle size for enhanced functionality in perovskite thin films deposited by metal organic deposition</i>	<b>Nature Asia Materials</b>	9	-	e447	10.1038/am.2017.197
	Suvorova, N.A.; Hamilton, V.T.; Oswald, D.M.; Balakirev, F.F.; Smilowitz, L.B. and Henson, B.F.,	<i>Studies of thermal dissolution of RDX in TNT melt</i>	<b>AIP Conference Proceedings</b>	1793	-	40009	10.1063/1.4971503

## 6.8. Applied Superconductivity Center

Cites NSF Core Grant	Authors	Title	Journal Name	Vol	Issue	Pages	DOI
X	Hu, X.; Rossi, L.; Strangl, A.; Sinclair, J.W.; Kametani, F.; Abraimov, D.; Polyanskii, A.; Coulter, J.Y.; Jaroszynskii, J. and Larbalestier, D.C.,	<i>An Experimental and analytical study of periodic and aperiodic fluctuations in the critical current of long coated conductors</i>	<b>IEEE Transactions on Applied Superconductivity</b>	27	-	9000205	10.1109/TASC.2016.2637330
X	Motowidlo, L.R.; Lee, P.J.; Tarantini, C.; Balachandran, S.; Ghosh, A.K. and Larbalestier, D.C.,	<i>An Intermetallic Powder-in-Tube Approach to Increased Flux-Pinning in Nb<sub>3</sub>Sn by Internal Oxidation of Zr</i>	<b>Superconductor Science and Technology</b>	31	1	14002	10.1088/1361-6668/aa980f
X	Sung, Z.-H.; Wang, M.; Polyanskii, A.A.; Santosh, C.; Balachandran, S.; Compton, C.; Larbalestier, D.C.; Bieler, T. R. and Lee, P.J.,	<i>Development of Low Angle Grain Boundaries in Lightly Deformed Superconducting Niobium and Their Influence on Hydride Distribution and Flux Perturbation</i>	<b>Journal of Applied Physics</b>	121	19	193903	10.1063/1.4983512
X	Hossain, S.I.; Jiang, J.; Mataras, M.; Trociewitz, U.P.; Lu, J.; Kametani, F.; Larbalestier, D. and Hellstrom, E.,	<i>Effect of sheath material and reaction overpressure on Ag protrusions into the TiO<sub>2</sub> insulation coating of Bi-2212 round wire</i>	<b>IOP Conference Series: Materials Science and Engineering</b>	279	1	12021	10.1088/1757-899X/279/1/012021
X	Chen, P.; Trociewitz, U.P.; Lu, J.; Bosque, E.S.; Jiang, J.; Hellstrom, E.E. and Larbalestier, D.C.,	<i>Experimental Study of Potential Heat Treatment Issues of Large Bi-2212 Coils</i>	<b>IEEE Transactions on Applied Superconductivity</b>	27	4	4601405	10.1109/TASC.2017.2652849
X	Lee, J.; Jiang, J.; Kametani, F.; Oh, M.J.; Weiss, J.; Colantones, Y.; Seo, S.; Yoon, S.; Tarantini, C.; Jo, Y.J.; Hellstrom, E. and Lee, S.,	<i>High critical current density over 1 MA cm<sup>-2</sup> at 13 T in BaZrO<sub>3</sub> incorporated Ba(Fe,Co)<sub>2</sub>As<sub>2</sub> thin film</i>	<b>Superconductor Science and Technology</b>	30	-	85006	10.1088/1361-6668/aa73f5

# Chapter 6 – Accomplishments & Discoveries

Cites NSF Core Grant	Authors	Title	Journal Name	Vol	Issue	Pages	DOI
X	Iida, K.; Sato, H.; Tarantini, C.; Hänisch, J.; Jaroszynski, J.; Hiramatsu, H.; Holzapfel, B. and Hosono, H.,	<i>High-field transport properties of a P-doped BaFe<sub>2</sub>As<sub>2</sub> film on technical substrate</i>	<b>Nature Scientific Reports</b>	7	-	39951	10.1038/srep39951
X	Segal, C.; Tarantini, C.; Lee, P.J. and Larbalestier, D.C.,	<i>Improvement of small to large grain A15 ratio in Nb<sub>3</sub>Sn PIT wires by inverted multistage heat treatments</i>	<b>IOP Conference Series: Materials Science and Engineering</b>	279	1	12019	10.1088/1757-899X/279/1/012019
X	Xu, A.; Zhang, Y.; Heydari Gharahcheshmeh, M.; Yao, Y.; Galstyan, E.; Abraimov, D.; Kametani, F.; Polyanskii, A.; Jaroszynski, J.; Griffin, V.; Majkic, G.; Larbalestier, D.C. and Selvamanickam, V.,	<i>Je(4.2 K, 31.2T) beyond 1 kA/mm<sup>2</sup> of a ~3.2 μm thick, 20 mol% Zr-added MOCVD REBCO coated conductor</i>	<b>Nature Scientific Reports</b>	7	-	6853	10.1038/s41598-017-06881-x
X	Kim, S.; Hahn, S.; Kim, K. and Larbalestier, D.,	<i>Method for generating linear current-field characteristics and eliminating charging delay in no-insulation superconducting magnets</i>	<b>Superconductor Science and Technology</b>	30	-	35020	10.1088/1361-6668/aa56ff
X	Kim, K.; Kim, K.; Bhattarai, K.R.; Radcliff, K.; Jang, J.Y.; Hwang, Y.J.; Lee, S.G.; Yoon, S. and Hahn, S.,	<i>Quench behavior of a no-insulation coil wound with stainless steel cladding REBCO tape at 4.2 K</i>	<b>Superconductor Science and Technology</b>	30	-	75001	10.1088/1361-6668/aa6a8b
X	Grinenko, V.; Iida, K.; Kurth, F.; Efremov, D.V.; Drechsler, S.-L.; Cherniavskii, I.; Morozov, I.; Hänisch, J.; Förster, T.; Tarantini, C.; Jaroszynski, J.; Maiorov, B.; Jaime, M.; Yamamoto, A.; Nakamura, I.; Fujimoto, R.; Hatano, T.; Ikuta, H. and Hühne, R.,	<i>Selective mass enhancement close to the quantum critical point in BaFe<sub>2</sub>(As<sub>1-x</sub>P<sub>x</sub>)<sub>2</sub></i>	<b>Nature Scientific Reports</b>	7	-	4589	10.1038/s41598-017-04724-3
X	Ye, L.Y.; Li, P.; Jaroszynski, J.; Schwartz, J. and Shen, T.M.,	<i>Strain control of composite superconductors to prevent degradation of superconducting magnets due to a quench: I. Ag/Bi<sub>2</sub>Sr<sub>2</sub>CaCu<sub>2</sub>O<sub>x</sub> multifilament round wires</i>	<b>Superconductor Science and Technology</b>	30	-	25005	10.1088/0953-2048/30/2/025005
X	Horide, T.; Kametani, F.; Yoshioka, S.; Kitamura, T. and Matsumoto, K.,	<i>Structural Evolution Induced by Interfacial Lattice Mismatch in Self-Organized YBa<sub>2</sub>Cu<sub>3</sub>O<sub>7-δ</sub> Nanocomposite Film</i>	<b>American Chemical Society Nano</b>	11	-	1780	10.1021/acs.nano.6b07716
X	Yoon, S.; Seo, Y.; Lee, S.; Weiss, J.D.; Jiang, J.; Oh, M.J.; Lee, J.; Seo, S.; Jo, Y.J.; Hellstrom, E.E.; Hwang, J. and Lee, S.,	<i>Structural, electro-magnetic, and optical properties of Ba(Fe,Ni)<sub>2</sub>As<sub>2</sub> single-crystal thin film</i>	<b>Superconductor Science and Technology</b>	30	3	35001	10.1088/1361-6668/30/3/035001
X	Richter, S.; Kurth, F.; Iida, K.; Pervakov, K.; Pukenas, A.; Tarantini, C.; Jaroszynski, J.; Hänisch, J.; Grinenko, V.; Skrotzki, W.; Nielsch, K. and Hühne, R.,	<i>Superconducting properties of Ba(Fe<sub>1-x</sub>Ni<sub>x</sub>)<sub>2</sub>As<sub>2</sub> thin films in high magnetic fields</i>	<b>Applied Physics Letters</b>	110	-	22601	10.1063/1.4973522
X	Brown, M.; Bosque, E.; McRae, D.; Walsh, R.P.; Jiang, J.; Hellstrom, E.E.; Kim, Y.; Trociewitz, U.; Otto, A.;	<i>Tensile Properties and Critical Current Strain Limits of Reinforced Bi-2212 Conductors for High Field Magnets</i>	<b>IOP Conference Series: Materials Science and Engineering</b>	279	-	12022	10.1088/1757-899X/279/1/012022

# Chapter 6 – Accomplishments & Discoveries

Cites NSF Core Grant	Authors	Title	Journal Name	Vol	Issue	Pages	DOI
X	and Larbalestier, D.C., Nikolo, M.; Singleton, J.; Solenov, D.; Jiang, J.; Weiss, J.D. and Hellstrom, E.E.,	<i>Upper Critical and Irreversibility Fields in Ba(Fe<sub>0.92</sub>Co<sub>0.08</sub>)<sub>2</sub>As<sub>2</sub> and Ba(Fe<sub>0.91</sub>Co<sub>0.09</sub>)<sub>2</sub>As<sub>2</sub> Pnictide Bulk Superconductors</i>	<b>Journal of Supercon- ductivity and Novel Magnetism</b>	30	-	561-568	10.1007/s10 948-016- 3727-4
	Kim, K.; Bhattarai, K.R.; Jang, J.Y.; Hwang, Y.J.; Kim, K.; Yoon, S.; Lee, S.G. and Hahn, S.,	<i>Design and performance estimation of a 35 T 40mm no-insulation all- REBCO user magnet</i>	<b>Superconductor Science and Technology</b>	30	-	65008	10.1088/136 1- 6668/aa667 7
	Dao, V.Q.; Kim, T.; Tat, T.L.; Sung, H.; Choi, J.; Kim, K.; Hwang, C.S.; Park, M. and Yu, I.K.,	<i>Design of conduction cooling system for a high current HTS DC reactor</i>	<b>Journal of Physics: Conference Series</b>	871	-	12089	10.1088/174 2- 6596/871/1/ 012089
	Chen, P.; Trociewitz, U. P.; <sup>1</sup> , Davis, D. S.; Bosque, E. S.; Hilton, D. K.; <sup>1</sup> , Kim, Y.; Abraimov, D. V.; Starch, W. L.; Jiang, J.; Hellstrom, E. E.; and Larbalestier, D. C.,	<i>Development of a persistent super- conducting joint between Bi-2212/Ag alloy multifilamentary round wires</i>	<b>Superconductor Science and Tech- nology</b>	30	2	25020	10.1088/136 1- 6668/30/2/0 25020
	Jiang, J.; Francis, A.; Alicea, R.; Matras, M.; Kametani, F.; Trociewitz, U.P.; Hellstrom, E.E. and Larbalestier, D.C.,	<i>Effects of filament size on critical current density in overpressure pro- cessed Bi-2212 round wire</i>	<b>IEEE Transactions on Applied Supercon- ductivity</b>	27	4	6400104	10.1109/TAS C.2016.2627 817
	Seo, S.; Kang, J.; Oh, M.J.; Jeong, I.; Jiang, J.; Gu, G.; Lee, J.; Lee, J.; Noh, H.; Liu, M.; Gao, P.; Hellstrom, E.E.; Lee, J.; Jo, Y.J.; Eom, C. and Lee, S.,	<i>Origin of the emergence of higher T<sub>c</sub> than bulk in iron chalcogenide thin films</i>	<b>Scientific Report</b>	7	-	9994	10.1038/s41 598-017- 10383-1
	Bhattarai, K.R.; Kim, K.; Kim, S.; Lee, S. and Hahn, S.,	<i>Quench Analysis of a Multiwidth No- Insulation 7-T 78-mm REBCO Magnet</i>	<b>IEEE Transactions on Applied Supercon- ductivity</b>	27	4	4603505	10.1109/TAS C.2017.2669 962

## 6.9. Magnet Science & Technology

Cites NSF Core Grant	Authors	Title	Journal Name	Vol	Issue	Pages	DOI
X	Tan, X.; Li, H.; Xu, H.; Han, K.; Li, W. and Zhang, F.,	<i>A Cost-Effective Approach to Optimiz- ing Microstructure and Magnetic Properties in Ce<sub>17</sub>Fe<sub>78</sub>B<sub>6</sub> Alloys</i>	<b>Materials</b>	10	8	869	10.3390/ma 10080869
X	Marshall, W.S.; Bird, M.D.; Godeke, A.; Larbalestier, D.C.; Markiewicz, W.D. and White, M,	<i>Bi-2223 Test Coils for High Resolution NMR Magnets</i>	<b>IEEE Transactions on Applied Superconduc- tivity</b>	27	4	4	10.1109/TAS C.2017.2652 378
X	Lu, J.; Goddard; R.; Han, K. and Hahn, S.,	<i>Contact resistance between two REB- CO tapes under load and load cycles</i>	<b>Superconductor Sci- ence and Technology</b>	30	-	45005	10.1088/136 1- 6668/aa5b0 5
X	Kennon, E.L.; Orzali, T.; Xin, Y.; Vert, A.; Lind, A.G. and Jones, K.S.,	<i>Deactivation of electrically supersatu- rated Te-doped InGaAs grown by MOCVD</i>	<b>Journal of Materials Science</b>	52	18	10879- 10885	10.1007/s10 853-017- 1254-8
X	Han, K. and Zhou, X.,	<i>Effect of high magnetic field on the processing of pearlitic steels</i>	<b>Materials and Manu- facturing Processes</b>	1	-	1-8	10.1080/104 26914.2017. 1279303



# Chapter 6 – Accomplishments & Discoveries

Cites NSF Core Grant	Authors	Title	Journal Name	Vol	Issue	Pages	DOI
X	Li, W.; Han, K.; Niu, R.; Liang, T.; Lai, C; and Zhang, X.H.,	<i>Effect of Si and Y2O3 Additions on the Oxidation Behavior of Ni<sub>2</sub>Al (x = 5 or 10 wt%) Alloys at 1150 °C</i>	<b>Oxid Met</b>	11	-	1-23	10.1007/s11085-017-9814-5
X	Jiang, Q.; Chen, M.; Li, J.; Wang, M.; Zeng, X.; Bersara, T.; Lu, J.; Xin, Y.; Shan, X.; Pan, B.; Wang, C.; Lin, S.; Siegrist, T.; Xiao, Q. and Yu, Z.,	<i>Electrochemical doping of halide perovskites with ion intercalation</i>	<b>American Chemical Society Nano</b>	11	1	1073-1079	10.1021/acsnano.6b08004
X	Gao, J.; Varga, E.; Guo, W. and Vinen, W.F.,	<i>Energy spectrum of thermal counterflow turbulence in superfluid helium-4</i>	<b>Physical Review B</b>	96	-	94511	10.1103/PhysRevB.96.094511
X	Garceau, N.; Guo, W. and Dodamead T.,	<i>Gas propagation following a sudden loss of vacuum in a pipe cooled by He I and He II</i>	<b>IOP Conference Series: Materials Science and Engineering</b>	278	-	12068	10.1088/1757-899X/278/1/012068
X	Li, F.; Li, H.; Zheng, S.; You, J.; Han, K. and Zhai, Q.,	<i>Impacts of Modification of Alloying Method on Inclusion Evolution in RH Refining of Silicon Steel</i>	<b>Materials</b>	10	10	1206	10.3390/materials10101206
X	Lu, J.; McGuire, D.R.; Hill, S.; Niu, R.; Chan, K. and Martovetsky N.N.,	<i>Influence of heat treatment excursion on critical current and residual resistivity ratio of ITER Nb3Sn strands</i>	<b>Superconductor Science and Technology</b>	30	-	75007	10.1088/1361-6668/aa67ab
X	Ghosh, S.S.; Xin, Y.; Mao, Z. and Manousakis, E.,	<i>Interface between Sr2RuO4 and Ru-metal inclusion: Implications for its superconductivity</i>	<b>Physical Review B</b>	96	-	184506	10.1103/PhysRevB.96.184506
X	Brewer, W.M.; Xin, Y.; Hatem, C.; Diercks, D.; Truong, V.Q. and Jones, K.S.,	<i>Lateral Ge Diffusion During Oxidation of Si/SiGe Fins</i>	<b>Nano Letters</b>	17	-	2159-2164	10.1021/acsnanolett.6b04407
X	Lu, J.; Toplosky, V.J.; Goddard, R.E. and Han, K.,	<i>Low temperature physical properties of Co-35Ni-20Mo-10Cr alloy MP35N®</i>	<b>Cryogenics</b>	86	-	106-111	10.1016/j.cryogenics.2017.07.004
X	Voran, A.J.; Weijers, H.W.; Markiewicz, W.D.; Gundlach, S.R.; Jarvis, J.B. and Sheppard, W.R.,	<i>Mechanical Support of the NHMFL 32 T Superconducting Magnet</i>	<b>IEEE Transactions on Applied Superconductivity</b>	27	4	4300305	10.1109/TASC.2016.2637163
X	Martin, T.P.; Jones, K.S.; Camillo-Castillo, R.A.; Hatem, C.; Xin, Y. and Elliman, R.G.,	<i>Quantification of germanium-induced suppression of interstitial injection during oxidation of silicon</i>	<b>Journal of Materials Science</b>	52	17	10387-10392	10.1007/s10853-017-1196-1
X	Vanderlaan, M.; Stubbs, D.; Ledebor, K.; Ross, J.; Van Sciver, S. and Guo, W.,	<i>Repeatability Measurements of Apparent Thermal Conductivity of Multi-layer Insulation (MLI)</i>	<b>IOP Conference Series: Materials Science and Engineering</b>	278	-	12195	10.1088/1757-899X/278/1/012195
X	Yang, G.; Nanda, J.; Wang, B.; Chen, G. and Hallinan, D.T.,	<i>Self-Assembly of Large Gold Nanoparticles for Surface-Enhanced Raman Spectroscopy</i>	<b>ACS Applied Materials &amp; Interfaces</b>	9	15	13457-13470	10.1021/acsnano.7b01121
X	Gao, J.; Varga, E.; Guo, W.; and Vinen, W. F.,	<i>Statistical measurement of counterflow turbulence in superfluid helium-4 using He2 tracer-line tracking technique</i>	<b>Journal of Low Temperature Physics</b>	187	-	490-496	10.1007/s10909-016-1681-y
X	Zhao, C.C.; Zuo, X.W.; Wang, E.G. and Han, K.,	<i>Strength of Cu-28 wt% Ag composite solidified under high magnetic field followed by cold drawing</i>	<b>Metals and Materials International</b>	23	2	369-377	10.1007/s12540-017-6417-2

# Chapter 6 – Accomplishments & Discoveries

Cites NSF Core Grant	Authors	Title	Journal Name	Vol	Issue	Pages	DOI
X	Mastracci, B.; Takada, S. and Guo, W.,	<i>Study of particle motion in He II counterflow across a wide heat flux range</i>	<b>Journal of Low Temperature Physics</b>	187	-	446	10.1007/s10909-016-1734-2
X	Brown, M.; Bosque, E.; McRae, D.; Walsh, R.P.; Jiang, J.; Hellstrom, E.E.; Kim, Y.; Trociewitz, U.; Otto, A.; and Larbalestier, D.C.,	<i>Tensile Properties and Critical Current Strain Limits of Reinforced Bi-2212 Conductors for High Field Magnets</i>	<b>IOP Conference Series: Materials Science and Engineering</b>	279	-	12022	10.1088/1757-899x/279/1/012022
X	Mastracci, B. and Guo, W.,	<i>Visualization of grid-generated turbulence in He II using PTV</i>	<b>IOP Conference Series: Materials Science and Engineering</b>	278	-	12081	10.1088/1757-899x/278/1/012081
	Lu, J.; Hill, S.; McGuire, D.; Dellinger, K.; Nijhuis, A.; Wessel, W.A.J.; Krooshoop, H.J.G.; Chan, K. and Martovestky, N.N.,	<i>Comparative measurements of ITER Nb3Sn strands between two laboratories</i>	<b>IEEE Transactions on Applied Superconductivity</b>	27	5	6001004	10.1109/TASC.2017.2685502
	Zuo, X.W.; Zhu, J.Z.; An, B.L.; Han, K.; Li, R. and Wang, E.G.,	<i>Influence of Fe addition on microstructure and properties of Cu-Ag composite</i>	<b>Metals and Materials International</b>	23	5	974-983	10.1007/s12540-017-6656-2
	Breschi, M.; Cavallucci, L.; Ribani, P.L.; Gavrilin, A.V. and Weijers, H.W.,	<i>Modeling of Quench in the Coupled HTS Insert / LTS Outsert Magnet System of the NHMFL</i>	<b>IEEE Transactions on Applied Superconductivity</b>	27	5	4301013	10.1109/TASC.2017.2698214
	Johnson, W.L.; Vanderlaan, M.; Wood, J.J.; Rhys, N.O.; Guo, W.; Van Sciver, S. and Chato, D.J.,	<i>Repeatability of Cryogenic Multilayer Insulation</i>	<b>IOP Conference Series: Materials Science and Engineering</b>	278	-	12196	10.1088/1757-899x/278/1/012196
	Ren, K.Z.; Tan, X.H.; Li, H.Y.; Xu, H. and Han, K.,	<i>The Effects of the Addition of Dy, Nb, and Ga on Microstructure and Magnetic Properties of Nd2Fe14B/alpha-Fe Nanocomposite Permanent Magnetic Alloys</i>	<b>Microscopy and Microanalysis</b>	23	2	425-430	10.1017/S1431927616012770

## 6.10. Education (NHMFL at FSU only)

Cites NSF Core Grant	Authors	Title	Journal Name	Vol	Issue	Pages	DOI
X	Bremer, M. and Hughes, R.,	<i>How Novices Perceive the Culture of Physics</i>	<b>Journal of Women and Minorities in Science and Engineering</b>	23	2	174-194	10.1615/JWomenMinorScienEng.2017016953

## 6.11. CMT/E

Cites NSF Core Grant	Authors	Title	Journal Name	Vol	Issue	Pages	DOI
X	Lee, S.; Lee, W.-J.; van Tol, J.; Kuhns, P.L.; Reyes, A.P.; Berger, H. and Choi, K.-Y.,	<i>Anomalous spin dynamics in the coupled spin tetramer system CuSeO<sub>3</sub></i>	<b>Physical Review B</b>	95	-	54405	10.1103/PhysRevB.95.054405

# Chapter 6 – Accomplishments & Discoveries

Cites NSF Core Grant	Authors	Title	Journal Name	Vol	Issue	Pages	DOI
X	Rhodes, D.; Schoenemann, R.; Aryal, N.; Zhou, Q.; Zhang, Q.R.; Kampert, E.; Chiu, Y.-C.; Lai, Y.; Shimura, Y.; McCandless, G.T.; Chan, J.Y.; Paley, D.W.; Lee, J.; Finke, A.D.; Ruff, J.P.C.; Das, S.; Manousakis, E., and Balicas, L.,	<i>Bulk Fermi-surface of the Weyl type-II semi-metallic candidate gamma-MoTe2</i>	<b>Physical Review B</b>	96	-	16513-4	10.1103/PhysRevB.96.165134
X	Kawasaki, S.; Li, Z.; Kitahashi, M.; Lin, C.T.; Kuhns, P.L.; Reyes, A.P. and Zheng, G.-Q.,	<i>Charge-density-wave order takes over antiferromagnetism in <math>Bi_2Sr_{2-x}La_xCuO_6</math> superconductors</i>	<b>Nature Communications</b>	8	-	1267	10.1038/s41467-017-01465-9
X	Lai, Y.; Saunders, S.M.; Graf, D.; Gallagher, A.; K.-Chen, W.; Kametani, F.; Besara, T.; Siegrist, T.; Shehter, A. and Baumbach, R.E.,	<i>Correlated electron state in CeCu2Si2 controlled through Si to P substitution.</i>	<b>Phys. Rev. Materials</b>	1	-	34801	10.1103/PhysRevMaterials.1.034801
X	Sur, S. and Yang, K.,	<i>Coulomb interaction driven instabilities of sliding Luttinger liquids</i>	<b>Physical Review B</b>	96	-	75131	10.1103/PhysRevB.96.075131
X	Kuskovsky, I.L.; Mourokh, L.G.; Roy, B.; Ji, H.; Dhomkar, S.; Ludwig, J.; Smirnov, D. and Tamargo, M.C.,	<i>Decoherence in semiconductor nanostructures with type-II band alignment: All-optical measurements using Aharonov-Bohm excitons</i>	<b>Physical Review B</b>	95	-	16544-5	10.1103/PhysRevB.95.165445
X	Di Sante, D.; Fratini, S.; Dobrosavljevic, V. and Ciuchi, S.,	<i>Disorder-driven metal-insulator transitions in deformable lattices</i>	<b>Physical Review Letters</b>	118	-	36602	10.1103/PhysRevLett.118.036602
X	Jiang, Q.; Chen, M.; Li, J.; Wang, M.; Zeng, X.; Besara, T.; Lu, J.; Xin, Y.; Shan, X.; Pan, B.; Wang, C.; Lin, S.; Siegrist, T.; Xiao, Q. and Yu, Z.,	<i>Electrochemical doping of halide perovskites with ion intercalation</i>	<b>American Chemical Society Nano</b>	11	1	1073-1079	10.1021/acsnano.6b08004
X	Ronning, F.; Helm, T.; Shirer, K.; Bachmann, M.; Balicas, L.; Chan, M.; Ramshaw, B.; McDonald, R.; Balakirev, F.; Bauer, E.; Jaime, M. and Moll, P.,	<i>Electronic in-plane symmetry breaking at field-tuned quantum criticality in CeRhIn5</i>	<b>Nature</b>	548	-	313-317	10.1038/nature23315
X	Rhodes, D.; Chenet, D.A.; Janicek, B.E.; Nyby, C.; Lin, Y.; Jin, W.; Edelberg, D.; Mannebach, E.M.; Finney, N.; Antony, A.; Schiros, T.; Klarr, T.; Mazzoni, A.; Chin, M.L.; Chiu, Y.-C.; Zheng, W.; Zhang, Q.R.; Ernst, F.; Dadap, J.I.; Tong, X.; Ma, J.; Lou, R.; Wang, S.; Qian, T.; Ding, H.; Osgood, R.M.; Paley, D.W.; Lindenberg, A.M.; Huang,	<i>Engineering the Structural and Electronic Phases of MoTe2 through W Substitution</i>	<b>Nano Letters</b>	17	3	1616-1622	10.1021/acs.nanolett.6b04814

# Chapter 6 – Accomplishments & Discoveries

Cites NSF Core Grant	Authors	Title	Journal Name	Vol	Issue	Pages	DOI
	P.Y.; Pasupathy, A.N.; Dubey, M.; Hone, J.C. and Balicas, L.,						
X	Schoenemann, R.; Aryal, N.; Zhou, Q.; Chiu, Y.-C.; Chen, K.-W.; Martin, T.J.; McCandless, G.T.; Chan, J.Y.; Manousakis, E. and Balicas, L.,	<i>Fermi surface of the Weyl type-II semi-metallic candidate WP2</i>	<b>Physical Review B Rapid Communications</b>	96	-	12110 8(R)	10.1103/Ph ysRevB.96. 121108
X	Zheng, G.; Zhu, X.; Liu, Y.; Lu, J.; Ning, W.; Zhang, H.; Gao, W.; Han, Y.; Yang, J.; Du, H.; Yang, K.; Zhang, Y. and Tian, M.,	<i>Field-induced topological phase tran- sition from a three-dimensional Weyl semimetal to a two-dimensional mas- sive Dirac metal in ZrTe5</i>	<b>Physical Review B Rapid Communications</b>	96	-	12140 1	10.1103/Ph ysRevB.96. 121401
X	Bertaina, S.; Yue, G.; Dutoit, C.-E. and Chi- orescu, I.,	<i>Forbidden coherent transfer observed between two realizations of quasi- harmonic spin systems</i>	<b>Physical Review B</b>	96	-	24428	10.1103/Ph ysRevB.96. 024428
X	Gong, S.; Zhu, W.; Zhu, J.- X.; Sheng, D.N. and Yang, K.,	<i>Global phase diagram and quantum spin liquids in spin-1/2 triangular antiferromagnet</i>	<b>Physical Review B</b>	96	-	75116	10.1103/Ph ysRevB.96. 075116
X	Ramirez, D.; Besara, T.; Whalen, J.B. and Siegrist, T.,	<i>Growth of EuO single crystals at re- duced temperatures</i>	<b>Physical Review B</b>	95	1	01440 7(7)	10.1103/Ph ysRevB.95. 014407
X	Yang, K.,	<i>Interface and phase transition be- tween Moore-Read and Halperin 331 fractional quan-tum Hall states: Real- ization of chiral Majorana fermion</i>	<b>Physical Review B Rapid Communications</b>	96	-	24130 5	10.1103/Ph ysRevB.96. 241305
X	McCreary, A.; Simpson, J.; Wang, Y.; Rhodes, D.; Fujisawa, K.; Balicas, L.; Dubey, M.; Crespi, V.; Terrones, M. and Hight- Walker, A.,	<i>Intricate Resonant Raman Response in Anisotropic ReS2</i>	<b>Nano Letters</b>	17	-	5897	10.1021/ac s.nanolett.7 b01463
X	Jiang, Y.; Dun, Z.L.; Zhou, H.D.; Lu, Z.; Chen, K.-W.; Moon, S.; Besara, T.; Siegrist, T. M.; Baumbach, R. E.; Smirnov, D. and Jiang, Z.,	<i>Landau-level spectroscopy of massive Dirac fermions in single-crystalline ZrTe5 thin flakes</i>	<b>Physical Review B Rapid Communications</b>	96	-	04110 1(R)	10.1103/Ph ysRevB.96. 041101
X	Chan, C.H.; Brown, G. and Rikvold, P.A.,	<i>Macroscopically Constrained Wang- Landau Method for Systems with Multiple Order Parameters and its Application to Drawing Complex Phase Diagrams</i>	<b>Physical Review E</b>	95	-	53302	10.1103/Ph ysRevE.95.0 53302
X	Kweon, J.J.; Fu, R.; Choi, E.S. and Dalal, N.S.,	<i>Magic angle spinning NMR study of the ferroelectric transition of KH2PO4: definitive evidence of a displacive component</i>	<b>Journal of Physics- Condensed Matter</b>	29	-	16LT0 1	10.1088/13 61- 648X/aa63 8a
X	Zhang, X.-X.; Cao, T.; Lu, Z.; Lin, Y.-C.; Zhang, F.; Wang, Y.; Li, Z.; Hone, J.C.; Robinson, J.A.; Smirnov, D.; Louie, S.G. and Heinz, T.F.,	<i>Magnetic brightening and control of dark excitons in monolayer WSe2</i>	<b>Nature Nanotechnology</b>	12	-	883	10.1038/n ano.2017.1 05
X	Machado, F.L.A.; Soares, J.M.; Conceição, O.L.A.;	<i>Magnetic properties of the nano- composite CoFe2O4/FeCo-FeO at a</i>	<b>Journal of Magnetism and Magnetic Materials</b>	424	-	323	10.1016/j.j mmm.2016

# Chapter 6 – Accomplishments & Discoveries

Cites NSF Core Grant	Authors	Title	Journal Name	Vol	Issue	Pages	DOI
X	Choi, E.S. and Balicas, L., Lee, J.A.; Xin, Y.; Stolt, I.; Halperin, W.P.; Reyes, A.P.; Kuhns, P.L. and Chan, M.K.,	<i>high H/T regime Magnetic-field-induced vortex-lattice transition in HgBa<sub>2</sub>CuO<sub>4+δ</sub></i>	<b>Physical Review B</b>	95	-	24512	.10.079 10.1103/Ph ysRevB.95. 024512
X	Lu, L.; Song, M.; Liu, W.; Reyes, A.P.; Kuhns, P.; Lee, H.O.; Fisher, I.R. and Mitrović, V.F.,	<i>Magnetism and local symmetry breaking in a Mott insulator with strong spin orbit interactions</i>	<b>Nature Communications</b>	8	-	14407	10.1038/nc omms1440 7
X	Pradhan, N.R.; Talapatra, S.; Terrones, M.; Pulickel, A. and Balicas, L.,	<i>Optoelectronic Properties of Hetero- structures: The Most Recent Devel- opments Based on Graphene and Transition-Metal Dichalcogenides</i>	<b>IEEE Nanotechnology Magazine</b>	11	2	18-32	10.1109/M NANO.2017 .2676185
X	Wang, D.; Smyser, K.; Rhodes, D.; Balicas, L.; Pasupathy, A. and Her- man, I.P.,	<i>Passivating 1T'-MoTe2 Multilayers at Elevated Temperatures by Encap- sulation</i>	<b>Nanoscale</b>	9	-	13910 - 13914	10.1039/C7 NR04998F
X	Chen, K.-W.; Lai, Y.; Chiu, Y.-C.; Steven, S.; Besara, T.; Graf, D.; Siegrist, T.; Albrecht-Schmitt, T.E.; Balicas, L. and Baumbach, R.E.,	<i>Possible devil's staircase in the Kondo lattice CeSbSe</i>	<b>Physical Review B</b>	96	-	14421	10.1103/Ph ysRevB.96. 014421
X	Gong, S.; Zhu, W.; Sheng, D. N. and Yang, K.,	<i>Possible Nematic Spin Liquid in Spin-1 Antiferromagnetic System on the Square Lattice: Implication for the Nematic Paramagnetic State of FeSe</i>	<b>Physical Review B</b>	20	-	20513 2	10.1103/Ph ysRevB.95. 205132
X	Jiang, Y.; Thapa, S.; Sand- ers, G.D.; Stanton, C.J.; Zhang, Q.; Kono, J.; Lou, W.K.; Chang, K.; Hawkins, S.D.; Klem, J.F.; Pan, W.; Smirnov, D. and Jiang, Z.,	<i>Probing the semiconductor to semi- metal transition in InAs/GaSb double quantum wells by magneto-infrared spectroscopy</i>	<b>Physical Review B</b>	95	-	45116	10.1103/Ph ysRevB.95. 045116
X	Svanidze, E.; Besara, T.; Wang, J.K.; Geiger, D.; Prochaska, L.; Santiago, J.M.; Lynn, J.W.; Paschen, S.; Siegrist, T. and Moro- san, E.,	<i>Quantum Critical Point in the Sc- doped Itinerant Antiferromagnet TiAu</i>	<b>Physical Review B Rapid Communications</b>	95	22	22040 5(5)	10.1103/Ph ysRevB.95. 220405
X	Zhou, R.; Hirata, M.; Wu, T.; Vinograd, I.; Mayaffre, H.; Krämer, S.; Horvatić, M.; Berthier, C.; Reyes, A.P.; Kuhns, P.L.; Liang, R.; Hardy, W.N.; Bonn, D.A. and Julien, M.-H.,	<i>Quasiparticle Scattering off Defects and Possible Bound States in Charge- Ordered YBa<sub>2</sub>Cu<sub>3</sub>O<sub>y</sub></i>	<b>Physical Review Letters</b>	118	-	17001	10.1103/Ph ysRevLett.1 18.017001
X	Yue, G.; Chen, L.; Barreda, J.; Bevara, V.; Hu, L.; Wu, L.; Wang, Z.; Andrei, P.; Bertaina, S. and Chi- orescu, I.,	<i>Sensitive spin detection using an on- chip SQUID-waveguide resonator</i>	<b>Applied Physics Letters</b>	111	-	20260 1	10.1063/1. 5006693
X	Lanata, N.; Yao, Y.; Deng, X.; Dobrosavljevic, V. and Kotliar G.,	<i>Slave boson theory of orbital differ- entiation with crystal field effects: Application to UO<sub>2</sub></i>	<b>Physical Review Letters</b>	118	-	12640 1	10.1103/Ph ysRevLett.1 18.126401
X	Hoch, M.J.R.,	<i>Spin clusters and low energy excita- tions in rare earth kagome systems</i>	<b>Modern Physics Letters B</b>	31	1	16300 10-1 -	10.1142/S0 217984916

# Chapter 6 – Accomplishments & Discoveries

Cites NSF Core Grant	Authors	Title	Journal Name	Vol	Issue	Pages	DOI
						16300 10-24	300106
X	Man, H.; Guo, J.; Zhang, R.; Schoenemann, R.U.; Yin, Z.; Fu, M.; Stone, M.B.; Huang, Q.; Song, Y.; Wang, W.; Singh, D.; Lochner, F.; Hickel, T.; Eremin, I.; Harriger, L.; Lynn, J.W.; Broholm, C.; Balicas, L.; Si, Q. and Dai, P.,	<i>Spin excitations and the Fermi surface of superconducting FeS</i>	<b>Nature Quantum Materials</b>	2	-	14	10.1038/s41535-017-0019-6
X	Zhou, R.; Hirata, M.; Wu, T.; Vinograd, I.; Mayaffre, H.; Kramer, S.; Reyes, A.P.; Kuhns, P.; Liang, R.; Hardy, W.; Bonn, D. and Julien, M.-H.,	<i>Spin susceptibility of charge-ordered YBa<sub>2</sub>Cu<sub>3</sub>O<sub>y</sub> across the upper critical field</i>	<b>Proceedings of the National Academy of Sciences of the United States of America</b>	114	50	13148 - 13153	10.1073/pnas.1711445114
X	Mard, H.J.; Hoyos, J.A.; Miranda, E. and Dobrosavljevic, V.,	<i>Strong-disorder approach for the Anderson localization transition</i>	<b>Physical Review B</b>	96	-	45143	10.1103/PhysRevB.96.045143
X	Tran, S.; Yang, J.; Gillgren, N.; Espiritu, T.; Shi, Y.; Watanabe, K.; Taniguchi, T.; Moon, S.; Baek, H.; Smirnov, D.; Bockrath, M.; Chen, R. and Lau, C.N.,	<i>Surface transport and quantum Hall effect in ambipolar black phosphorus double quantum wells</i>	<b>Science Advances</b>	3	-	e1603 179	10.1126/sciadv.1603179
X	Tennakoon, S.; Gladden, J.; Mookherjee, M.; Bersara, T. and Siegrist, T.,	<i>Temperature-dependent elasticity of Pb[(Mg<sub>0.33</sub>Nb<sub>0.67</sub>)<sub>1-x</sub>Tix]O<sub>3</sub></i>	<b>Physical Review B</b>	96	13	13410 8	10.1103/PhysRevB.96.134108
X	Lu, J.; Zheng, G.; Zhu, X.; Ning, W.; Zhang, H.; Han, Y.; Yang, J.; Du, H.; Yang, K.; Lu, H.; Zhang, Y. and Tian, M.,	<i>Thickness-tuned transition of band topology in ZrTe<sub>5</sub> nanosheets</i>	<b>Physical Review B</b>	95	-	12513 5	10.1103/PhysRevB.95.125135
X	Abhyankar, N.; Kweon, J.J.; Orto, M.; Bertaina, S.; Lee, M.; Choi, E.S.; Fu, R. and Dalal, N.S.,	<i>Understanding Ferroelectricity in the Pb-Free Perovskite-Like Metal-Organic Framework [(CH<sub>3</sub>)<sub>2</sub>NH<sub>2</sub>]Zn(HCOO)<sub>3</sub>: Dielectric, 2D NMR, and Theoretical Studies</i>	<b>Journal of Physical Chemistry C</b>	121	11	6314- 6322	10.1021/acs.jpcc.7b00596
	Li, L.; Zhang, Y.; Xie, L.; Jokisaari, J.R.; Beekman, C.; Yang, J.-C.; Chu, Y.-H.; Christen, H.M. and Pan, X.,	<i>Atomic-scale mechanisms of defect induced retention failure in ferroelectrics</i>	<b>Nano Letters</b>	17	6	3556- 3562	10.1021/acs.nanolett.7b00696
	Lanata, N.; Lee, T. G.; Yao, Y. and Dobrosavljevic, V.,	<i>Emergent Bloch excitations in Mott matter</i>	<b>Physical Review B</b>	96	-	19512 6	10.1103/PhysRevB.96.195126
	Vafek, O.; Regnault, N. and Bernevig, B.A.,	<i>Entanglement of exact excited eigenstates of the Hubbard model in arbitrary dimension</i>	<b>SciPost Phys.</b>	3	-	34	10.21468/SciPostPhys.3.6.043
	Ekuma, C.E.; Dobrosavljevic, V. and Gunlycke, D.,	<i>First-principles-based method for electron localization: Application to monolayer hexagonal boron nitride</i>	<b>Physical Review Letters</b>	118	-	10640 4	10.1103/PhysRevLett.118.106404

# Chapter 6 – Accomplishments & Discoveries

Cites NSF Core Grant	Authors	Title	Journal Name	Vol	Issue	Pages	DOI
	Buendia, G.M. and Rikvold, P.A.,	<i>Fluctuations in a Model Ferromagnetic Film Driven by a Slowly Oscillating Field with a Constant Bias</i>	<b>Physical Review B</b>	96	-	13430-6	10.1103/PhysRevB.96.134306
	Vafeek, O. and Chubukov, A.V.,	<i>Hund Interaction, Spin-Orbit Coupling, and the Mechanism of Superconductivity in Strongly Hole-Doped Iron Pnictides</i>	<b>Physical Review Letters</b>	118	-	87003	10.1103/PhysRevLett.118.087003
	Hagmann, J.A.; Le, S.T.; Schneemeyer, L.F.; Stroschio, J.A.; Besara, T.; Sun, J.; Singh, D.J.; Siegrist, T.; Seiler, D.G. and Richter, C.A.,	<i>Interacting Nanoscale Magnetic Superatom Cluster Arrays in Molybdenum Oxide Bronzes</i>	<b>Nanoscale</b>	9	-	7922-7929	10.1039/C7NR01087G
	Shi, X.; Shi, Z. and Popovic, D.,	<i>Low-temperature resistance noise spectroscopy as a probe of the superconducting transition in underdoped <math>La_{2-x}Sr_xCuO_4</math></i>	<b>Proc. SPIE</b>	10105	-	10105-03	10.1117/12.2267197
	Nishino, M.; Miyashita, S. and Rikvold, P.A.,	<i>Nontrivial phase diagram for an elastic interaction model of spin crossover materials with antiferromagnetic-like short-range interactions</i>	<b>Physical Review B</b>	96	-	14442-5	10.1103/PhysRevB.96.144425
	Chan, C.H.; Brown, G. and Rikvold, P.A.,	<i>Phase Diagrams and Free-energy Landscapes for Model Spin-crossover Materials with Antiferromagnetic-like Nearest-neighbor and Ferromagnetic-like Long-range Interactions</i>	<b>Physical Review B</b>	96	-	17442-8	10.1103/PhysRevB.96.174428
	Ho, V.X.; Dao, T.V.; Jiang, H.X.; Lin, J.Y.; Zavada, J.M.; McGill, S.A. and Vinh, N.Q.,	<i>Photoluminescence quantum efficiency of Er optical centers in GaN epilayers</i>	<b>Nature Scientific Reports</b>	7	-	39997	10.1038/srrep39997
	Najera, O.; Civelli, M.; Dobrosavljevic, V. and Rozenberg, M.,	<i>Resolving the VO2 controversy: Mott mechanism dominates the insulator-to-metal transition</i>	<b>Physical Review B</b>	95	-	35113	10.1103/PhysRevB.95.035113
	Tesler, F.; Tang, S.; Dobrosavljevic, V. and Rozenberg, M.,	<i>Shock waves in binary oxides memristors</i>	<b>Spintronics X, Proc. SPIE</b>	10357	-	10357-2L	10.1117/12.2277977
	Liou, S.; Hu, Z. and Yang, K.,	<i>Topological Quantum Phase Transition from Fermionic Integer Quantum Hall Phase to Bosonic Fractional Quantum Hall Phase through P-Wave Feshbach Resonance</i>	<b>Physical Review B Rapid Communications</b>	95	-	24110-6	10.1103/PhysRevB.95.241106
	Li, A.J.; Zhu, X.; Rhodes, D.; Samouche, C.C.; Balicas, L. and Hebard, A.F.,	<i>Van der Waals Schottky barriers as interface probes of the correlation of chemical potential shifts with charge density wave formation in 1T-TiSe2 and 2H-NbSe2</i>	<b>Physical Review B</b>	96	-	12530-1	10.1103/PhysRevB.96.125301

## 6.12. Geochemistry Facility

Cites NSF Core Grant	Authors	Title	Journal Name	Vol	Issue	Pages	DOI
<b>X</b>	Stacklyn, S.; Wang, Y.; Jin, C.; Wang, Y.; Sun, F., Zhang, C.; Jiang, S. and Deng, T.,	<i>Carbon and oxygen isotopic evidence for diets, environments and niche differentiation of early Pleistocene pandas and associated mammals in South China.</i>	<b>Palaeogeography, Palaeoclimatology, Palaeoecology</b>	468	-	351-361	10.1016/j.palaep.2016.12.015

# Chapter 6 – Accomplishments & Discoveries

Cites NSF Core Grant	Authors	Title	Journal Name	Vol	Issue	Pages	DOI
X	Bausch, A.R.; Boatta, F.; Morton, P.L.; McKee, K.T.; Anderson, R.F.; Gomes, H.R. and Goes, J.I.,	<i>Elevated toxic effect of sediments on growth of the harmful dinoflagellate <i>Cochlodinium polykrikoides</i> under high CO<sub>2</sub></i>	<b>Aquatic Microbial Ecology</b>	80	2	139-152	10.3354/ame01848
X	Wu, X.J.; Wang, X.S.; Wang, Y. and Hu, X.,	<i>Origin of water in the Badain Jaran Desert, China: New insight from isotopes.</i>	<b>Hydrology and Earth System Sciences</b>	21	-	4419-4431	10.5194/hess-21-4419-2017
X	Bowman, C.; Wang, Y.; Wang, X.; Takeuchi, G.; Faull, M.; Whistler, D. and Kish, S.,	<i>Pieces of the puzzle: Lack of significant C4 in the late Miocene of southern California.</i>	<b>Palaeogeography, Palaeoclimatology, Palaeoecology</b>	475	-	70-79	10.1016/j.palaeo.2017.03.008
X	Ebling, A.M. and Landing, W.M.,	<i>Trace elements in the sea surface microlayer: rapid responses to changes in aerosol deposition</i>	<b>Elementa: Science of the Anthropocene</b>	5	-	42	10.1525/elementa.237
	Ostrander, C.M.; Owens, J.D. and Nielsen, S.G.,	<i>Constraining the rate of oceanic deoxygenation leading up to a Cretaceous Oceanic Anoxic Event (OAE-2: ~94 Ma)</i>	<b>Science Advances</b>	3	8	e1701020	10.1126/sciadv.1701020
	Them, T.R. II.; Gill, B.C.; Selby, D.; Gröcke, D.R.; Friedman, R. and Owens, J.D.,	<i>Evidence for rapid weathering response to climatic warming during the Toarcian Oceanic Anoxic Event</i>	<b>Nature Scientific Reports</b>	7	-	5003	10.1038/s41598-017-05307-y
	Warren, M.J.; Lin, X.; Gaby, J.C.; Kretz, C.B.; Kolton, M.; Morton, P.L.; Pett-Ridge, J.; Weston, D.J.; Schadt, C.W.; Kostka, J.E. and Glass, J.B.,	<i>Molybdenum-based diazotrophy in a Sphagnum peatland in northern Minnesota</i>	<b>Applied and Environmental Microbiology</b>	83	17	e01174-17	10.1128/AEM.01174-17
	Liu, R.; Hu, L. and Humayun, M.,	<i>Natural variations in rhenium isotopic composition of meteorites.</i>	<b>Meteoritics and Planetary Sciences</b>	52	-	479-492	10.1111/maps.12803
	Zhou, X.; Jenkyns, H.C.; Lu, W.; Hardisty, D.S.; Owens, J.D.; Lyons, T.W. and Lu Z.,	<i>Organically bound iodine as a bottom-water redox proxy: Preliminary validation and application</i>	<b>Chemical Geology</b>	457	-	95-106	10.1016/j.chemgeo.2017.03.016
	Goderis, S.; Brandon, A.D.; Mayer, B. and Humayun, M.,	<i>Osmium isotopic homogeneity in the CK carbonaceous chondrites.</i>	<b>Geochimica et Cosmochimica Acta</b>	216	-	8-27	10.1016/j.gca.2017.05.011
	Owens, J.D.; Lyons, T.W.; Hardisty, D.S.; Lowery, C.M.; Lu, Z.; Lee, B. and Jenkyns, H.C.,	<i>Patterns of local and global redox variability during the Cenomanian-Turonian Boundary Event (Oceanic Anoxic Event 2) recorded in carbonates and shales from central Italy</i>	<b>Sedimentology</b>	64	1	168-185	10.1111/sed.12352
	Shelley, R.U.; Roca-Martí, M.; Castrillejo, M.; Masqué, P.; Landing, W.M.; Planquette, H. and Sarthou, G.,	<i>Quantification of trace element atmospheric deposition fluxes to the Atlantic Ocean</i>	<b>Deep Sea Research Part I: Oceanographic Research Papers</b>	119	-	34-49	10.1016/j.dsr.2016.11.010
	Hewins, R.H.; Zanda, B.; Humayun, M.; Nemchin, A.; Lorand, J.-P.; Pont, S.; Deldicque, D.; Bellucci, J.J.; Beck, P.; Leroux, H.; Marinova, M.; Remusat, L.; Göpel, C.; Lewin, E.; Grange, M.; Kennedy, A. and Whitehouse, M.J.,	<i>Regolith breccia North West Africa 7533: Mineralogy and petrology with implications for early Mars.</i>	<b>Meteoritics and Planetary Sciences</b>	52	-	89-124	10.1111/maps.12740



# Chapter 6 – Accomplishments & Discoveries

Cites NSF Core Grant	Authors	Title	Journal Name	Vol	Issue	Pages	DOI
	Owens, J.D.; Nielsen, S.G.; Horner, T.J.; Ostrander, C.M. and Peterson, L.,	<i>Thallium-isotopic compositions of euxinic sediments as a proxy for global manganese-oxide burial</i>	<b>Geochimica et Cosmochimica Acta</b>	213	-	29-307	10.1016/j.gca.2017.06.041

## 6.13. MBI at UF

Cites NSF Core Grant	Authors	Title	Journal Name	Vol	Issue	Pages	DOI
X	Perez, P.D.; Hall, G.; Zubcevic, J. and Febo, M.,	<i>Cocaine differentially affects synaptic activity in memory and mid-brain areas of female and male rats: an in vivo MEMRI study</i>	<b>Brain Imaging and Behavior</b>	1	1	1-16	10.1007/s11682-017-9691-1
X	Szymkowicz, S.M.; McLaren, M.E.; O'shea, A.; Woods, A.J.; Anton, S.D. and Dotson, V.M.,	<i>Depressive symptoms modify age effects on hippocampal subfields in older adults</i>	<b>Geriatrics &amp; Gerontology International</b>	17	10	1494-1500	10.1111/ggi.12901
X	Kasinadhuni, A.K.; Indahlastari, A.; Chauhan, M.; Schär, M.; Mareci, T.H. and Sadleir, R.J.,	<i>Imaging of current flow in the human head during transcranial electrical therapy</i>	<b>Brain Stimulation</b>	10	4	764-772	10.1016/j.brs.2017.04.125
X	Willcocks, R.J.; Triplett, W.T.; Forbes, S.C.; Arora, H.; Senesac, C.R.; Lott, D.J.; Nicholson, T.R.; Rooney, W.D.; Walter, G.A. and Vandenborne, K.,	<i>Magnetic resonance imaging of the proximal upper extremity musculature in boys with Duchenne muscular dystrophy</i>	<b>Journal of Neurology</b>	264	1	64-71	10.1007/s00415-016-8311-0
X	Zubcevic, J.; Watkins, J.; Perez, P.D.; Colon-Perez, L.M.; Long, M.T.; Febo, M. and Hayward, L.F.,	<i>MEMRI reveals altered activity in brain regions associated with anxiety, locomotion, and cardiovascular reactivity on the elevated plus maze in the WKY vs SHR rats</i>	<b>Brain Imaging and Behavior</b>	1	1	1-16	10.1007/s11682-017-9798-4
X	Szymkowicz, S.M.; Dotson, V.M.; McLaren, M.E.; De Wit, L.; O'Shea, D.M.; Talty, F.T.; O'Shea, A.; Porges, E.C.; Cohen, R.A. and Woods, A.J.,	<i>Precuneus abnormalities in middle-aged to older adults with depressive symptoms: An analysis of BDI-II symptom dimensions</i>	<b>Psychiatry Research-Neuroimaging</b>	268		9-14	10.1016/j.psychresns.2017.08.002
X	McLaren, M.E.; Szymkowicz, S.M.; O'Shea, A.; Woods, A.J.; Anton, S.D. and Dotson, V.M.,	<i>Vertex-wise examination of depressive symptom dimensions and brain volumes in older adults</i>	<b>Psychiatry Research-Neuroimaging</b>	260		70-75	10.1016/j.psychresns.2016.12.008
	Sege, C.T.; Bradley, M.M.; Weymar, M. and Lang, P.J.,	<i>A direct comparison of appetitive and aversive anticipation: Overlapping and distinct neural activation</i>	<b>Behavioural Brain Research</b>	326		93-102	10.1016/j.bbr.2017.03.005
	Jones, J.D.; Tanner, J.J.; Okun, M.; Price, C.C. and Bowers, D.,	<i>Are Parkinson's Patients More Vulnerable to the Effects of Cardiovascular Risk: A Neuroimaging and Neuropsychological Study</i>	<b>Journal of the International Neuropsychological Society</b>	23	4	322-331	10.1017/S1355617717000017
	Cruz-Almeida, Y.; Rosso, A.; Marcum, Z.; Harris, T.; Newman, A.B.; Nevitt, M.; Satterfield, S.; Yaffe, K.; Rosano, C. and Health ABC Study,	<i>Associations of Musculoskeletal Pain With Mobility in Older Adults: Potential Cerebral Mechanisms</i>	<b>Journals of Gerontology Series A: Biomedical Sciences and Medical Sciences</b>	72		1270-1276	10.1093/gerona/glx084

# Chapter 6 – Accomplishments & Discoveries

Cites NSF Core Grant	Authors	Title	Journal Name	Vol	Issue	Pages	DOI
	Boissoneault, J.; Sevel, L.; Letzen, J.; Robinson, M. and Staud, R.,	<i>Biomarkers for Musculoskeletal Pain Conditions: Use of Brain Imaging and Machine Learning</i>	<b>Current Rheumatology Reports</b>	19	1	5	10.1007/s11926-017-0629-9
	Salazar, T.E.; Richardson, M.R.; Beli, E.; Ripsch, M.S.; George, J.; Kim, Y.; Duan, Y.; Moldovan, L.; et. l.	<i>Electroacupuncture Promotes Central Nervous System-Dependent Release of Mesenchymal Stem Cells</i>	<b>Stem Cells</b>	35	5	1303-1315	10.1002/stem.2613
	Thompson, P.M.; Andreassen, O.A.; Arias-Vasquez, A; Bearden, C.E.; et.al.	<i>ENIGMA and the individual: Predicting factors that affect the brain in 35 countries worldwide</i>	<b>NeuroImage</b>	145		389-408	10.1016/j.neuroimage.2015.11.057
	Ofori, E.; Krismer, F.; Burciu, R.G.; Pasternak, O.; McCracken, J.L.; Lewis, M.M.; Du, G.; McFarland, N.R.; Okun, M.S.; Poewe, W. and Mueller, C.,	<i>Free Water Improves Detection of Changes in the Substantia Nigra in Parkinsonism: A Multisite Study</i>	<b>Movement Disorders</b>	32	10	1457-1464	10.1002/mds.27100
	Archer, D.B.; Patten, C. and Coombes, S.A.,	<i>Free-Water and Free-Water Corrected Fractional Anisotropy in Primary and Premotor Corticospinal Tracts in Chronic Stroke</i>	<b>Human Brain Mapping</b>	38	9	4546-4562	10.1002/hbm.23681
	Nissim, N.R.; O'Shea, A.M.; Bryant, V.; Porges, E.C.; Cohen, R. and Woods, A.J.,	<i>Frontal Structural Neural Correlates of Working Memory Performance in Older Adults</i>	<b>Frontiers in Aging Neuroscience</b>	8		328	10.3389/fnagi.2016.00328
	Burciu, R.G.; Hess, C.W.; Coombes, S.A.; Ofori, E.; Shukla, P.; Chung, J.W.; McFarland, N.R.; Wagle Shukla, A.; Okun, M.S. and Vaillancourt, D.E.,	<i>Functional Activity of the Sensorimotor Cortex and Cerebellum Relates to Cervical Dystonia Symptoms</i>	<b>Human Brain Mapping</b>	38	9	4563-4573	10.1002/hbm.23684
	Ziaei, M.; Ebner, N.C. and Burianová, H.,	<i>Functional brain networks involved in gaze and emotional processing</i>	<b>European Journal of Neuroscience</b>	45	2	312-320	10.1111/ejn.13464
	Persson, N.; Lavebratt, C.; Ebner, N.C. and Fischer, H.,	<i>Influence of DARPP-32 genetic variation on BOLD activation to happy faces</i>	<b>Social Cognitive and Affective Neuroscience</b>	12	20	1658-1667	10.1093/scan/nsx089
	Smith, B.K.; Martin, A.D.; Lawson, L.A.; Vernot, V.; Marcus, J.; Islam, S.; Shafi, N.; Corti, M.; Collins, S.W. and Byrne, B.J.,	<i>Inspiratory muscle conditioning exercise and diaphragm gene therapy in Pompe disease: Clinical evidence of respiratory plasticity</i>	<b>Experimental Neurology</b>	287		216-224	10.1016/j.expneurol.2016.07.013
	Boissoneault, J.; Vathauer, K.; O'Shea, A.; Craggs, J.G.; Robinson, M.; Staud, R.; Berry, R.B.; Perlstein, W.; Waxenberg, L. and McCrae, C.S.,	<i>Low-to-Moderate Alcohol Consumption is Associated With Hippocampal Volume in Fibromyalgia and Insomnia</i>	<b>Biochemical and Biophysical Research Communications</b>	15	6	438-450	10.1080/15402002.2016.1150279
	Huang, H.; Nguyen, P.T.; Schwab, N.A.; Tanner, J.J.; Price, C.C. and Ding, M.,	<i>Mapping Dorsal and Ventral Caudate in Older Adults: Method and Validation</i>	<b>Frontiers in Aging Neuroscience</b>	9	91	13	10.3389/fnagi.2017.00091

# Chapter 6 – Accomplishments & Discoveries

Cites NSF Core Grant	Authors	Title	Journal Name	Vol	Issue	Pages	DOI
	Bril, F.; Barb, D.; Portillo-Sanchez, P.; Biernacki, D.; Lomonaco, R.; Suman, A.; Weber, M.H.; Budd, J.T.; Lupi, M.E. and Cusi, K.,	<i>Metabolic and Histological Implications of Intrahepatic Triglyceride Content in Nonalcoholic Fatty Liver Disease</i>	<b>Hepatology</b>	65	4	1132-1144	10.1002/hep.28985
	Petro, N.M.; Gruss, L.F.; Yin, S.; Huang, H.; Miskovic, V.; Ding, M. and Keil, A.,	<i>Multimodal Imaging Evidence for a Frontoparietal Modulation of Visual Cortex during the Selective Processing of Conditioned Threat</i>	<b>Journal of Cognitive Neuroscience</b>	29	6	953-967	10.1162/jocn_a_01114
	Bennion, D.M.; Isenberg, J.D.; Harmel, A.T.; DeMars, K.; Dang, A.N.; Jones, C.H.; Pignataro, M.E.; Graham, J.T.; Stecklings, U.M.; Alexander, J.C.; Febo, M.; Krause, E.G.; de Kloet, A.D.; Candelario-Jalil, E. and Sumners, C.,	<i>Post-stroke angiotensin II type 2 receptor activation provides long-term neuroprotection in aged rats</i>	<b>PLoS ONE</b>	12	7	e0180738	10.1371/journal.pone.0180738
	Burciu, R.G., Ofori, E., Archer, D.B., Wu, S.S., Pasternak, O., McFarland, N.R., Okun, M.S. and Vaillancourt, D.E.,	<i>Progression marker of Parkinson's disease: a 4-year multi-site imaging study</i>	<b>Brain</b>	140		2183-2192	10.1093/brain/awx146
	Burakiewicz, J.; Sinclair, C.D.; Fischer, D.; Walter, G.A.; Kan, H.E. and Hollingsworth, K.G.,	<i>Quantifying fat replacement of muscle by quantitative MRI in muscular dystrophy</i>	<b>Journal of Neurology</b>	264	10	2053-2067	10.1007/s00415-017-8547-3
	Kang, N.; Christou, E.A.; Burciu, R.G.; Chung, J.W.; DeSimone, J.C.; Ofori, E.; Ashizawa, T.; Subramony, S.H. and Vaillancourt, D.E.,	<i>Sensory and motor cortex function contributes to symptom severity in spinocerebellar ataxia type 6</i>	<b>Brain Structure and Function</b>	222	2	1039-1052	10.1007/s00429-016-1263-4
	Calvani, R.; Marini, F.; Cesari, M.; Buford, T.W.; Manini, T.M.; Pahor, M., Leeuwenburgh, C.; Bernabei, R.; Landi, F. and Marzetti, E.,	<i>Systemic inflammation, body composition, and physical performance in old community-dwellers</i>	<b>Journal of Cachexia Sarcopenia Muscle</b>	8	1	69-77	10.1002/jcsm.12134
	Lehericy, S.; Vaillancourt, D.E.; Seppi, K.; Monchi, O.; Rektorova, I.; Antonini, A.; McKeown, M.J.; Masellis, M.; Berg, D.; Rowe, J.B. and Lewis, S.J.,	<i>The Role of High-Field Magnetic Resonance Imaging in Parkinsonian Disorders: Pushing the Boundaries Forward</i>	<b>Movement Disorders</b>	32	4	510-525	10.1002/mds.26968

# Chapter 6 – Accomplishments & Discoveries

## 6.14. UF Physics

Cites NSF Core Grant	Authors	Title	Journal Name	Vol	Issue	Pages	DOI
X	Anderton, K.J.; Ermert, D.M.; Quintero, P.A.; Turvey, M.W.; Fataftah, M.S.; Abboud, K.A.; Meisel, M.W.; Čičimár, E. and Murray, L.J.,	<i>Correlating Bridging Ligand with Properties of Ligand-Templated [MnII3X3]3+ Clusters (X = Br, Cl, H, MeO)</i>	<b>Inorganic Chemistry</b>	56		12012-12022	10.1021/acs.inorgchem.7b02004
X	Mihalik, M.; Mihalik, M.; Hoser, A.; Pajerowski, D.M.; Kriegner, D.; Legut, D.; Lebecki, K.M.; Vavra, M.; Fitta, M. and Meisel, M.W.,	<i>Determination of the Magnetic Structure of NdMn0.8Fe0.2O3</i>	<b>Physical Review B</b>	96		134430	10.1103/PhysRevB.96.134430
X	Peprah, M.K.; VanGennep, D.; Blasiola, B.D.; Quintero, P.A.; Tarasenko, R.; Xia, J.S.; Hamlin, J.J.; Meisel, M.W. and Orendáčová, A.,	<i>Influence of Pressure on the Magnetic Response of the Low-Dimensional Quantum Magnet Cu(H<sub>2</sub>O)<sub>2</sub>(C<sub>2</sub>H<sub>8</sub>N<sub>2</sub>)SO<sub>4</sub></i>	<b>Acta Physica Polonica A</b>	131	4	901-903	10.12693/APhysPolonA.131.901
X	Sullivan, N.S.; Hamida, J.A.; Muttalib, K.; Pilla, S. and Genio, E.,	<i>Oriental Glasses: NMR and Electric Susceptibility Studies</i>	<b>Magnetochemistry</b>	3	4	33-54	10.3390/magnetochemistry3040033
X	DeHaven, B.A.; Tokarski, J.T., III.; Korous, A.A.; Mentink-Vigier, F.; Makris, T.M.; Brugh, A.M.; Forbes, M.D.E.; van Tol, J.; Bowers, C.R. and Shimizu, L.S.,	<i>Persistent Radicals of Self-assembled Benzophenone bis-urea Macrocycles: Characterization and Application as a Polarizing Agent for Solid-state DNP MAS Spectroscopy</i>	<b>Chemistry a European Journal</b>	23		6-Jan	10.1002/chem.201701705
X	Huan, C.; Yin, L.; Xia, J.S.; Cowan, D., Sullivan, N. S. and Candela, D.,	<i>Phase separation in dilute solutions of <sup>3</sup>He in solid <sup>4</sup>He</i>	<b>Physical Review B</b>	95		104107	10.1103/PhysRevB.95.104107
X	Dutta, A.R.; Sekar, P.; Dvoyashkin, M.; Bowers, C.; Ziegler, K.J. and Vasenkov, S.,	<i>Possible role of molecular clustering in single-file diffusion of mixed and pure gases in dipeptide nanochannels</i>	<b>Microporous and Mesoporous Media</b>	early view		5-Jan	10.1016/j.micromeso.2017.05.025
X	VanGennep, D.; Linscheld, A.; Jackson, D.E.; Weor, S.T.; Vohra, Y.K.; Berger, H.; Stewart, G.R.; Hennig, R.G.; Hirschfeld, P.J. and Hamlin, J.J.,	<i>Pressure-induced superconductivity in the giant Rashba system BiTeI</i>	<b>Journal of Physics-Condensed Matter</b>	29	9	09LT02	10.1088/1361-648X/aa5567
X	Peprah, M.K.; VanGennep, D.; Quintero, P.A.; Risset, O.N.; Brinzari, T.V.; Li, C.H.; Dumont, M.F.; Xia, J.S.; Hamlin, J.J.; Talham, D.R. and Meisel, M.W.,	<i>Pressure-tuning of the photomagnetic response of heterostructured CoFe@CrCr-PBA core@shell nanoparticles</i>	<b>Polyhedron</b>	123		323-327	10.1016/j.poly.2016.11.046
	Zheng, P.; Jiang, W.G.; Barquist, C.S.; Lee, Y. and Cha, H.B.,	<i>Anomalous Resonance Frequency Shift of a Microelectromechanical Oscillator in Superfluid <sup>3</sup>He-B</i>	<b>Journal of Low Temperature Physics</b>	187	3	309-323	10.1007/s10909-017-1752-8
	Zheng, P.; Jiang, W.G.; Barquist, C.S.; Lee, Y. and Chan, H.B.,	<i>Critical velocity in the Presence of Surface Bound Superfluid He-3-B</i>	<b>Physical Review Letters</b>	118	6	65301	10.1103/PhysRevLett.118.065301

# Chapter 6 – Accomplishments & Discoveries

Cites NSF Core Grant	Authors	Title	Journal Name	Vol	Issue	Pages	DOI
	Sprau, P.O.; Kostin, A.; Kreisel, A.; Boehmer, A.; Canfield, P.C.; Hirschfeld, P.J.; Andersen, B.M. and Davis, J.C.,	<i>Discovery of orbitally selective nematic Cooper pairing in FeSe</i>	<b>Science</b>	357		75	10.1126/science.aal1575
	Maiti, S; Chubukov, A. and Hirschfeld, P.J.,	<i>Gauge invariance, vertex corrections and screening in Raman spectroscopy</i>	<b>Physical Review B</b>	96		14503	10.1103/PhysRevB.96.014503
	Choubey, P.; Tu, W.-L.; Lee, T.-K. and Hirschfeld, P.J.,	<i>Incommensurate charge ordered states in the t-t'-J model</i>	<b>New Journal of Physics</b>	19		13028	10.1088/1367-2630/19/1/013028
	Kreisel, A.; Sprau, P.O.; Kostin, A.; Davis, J.C.; Andersen, B.M. and Hirschfeld, P.J.,	<i>Orbital selective spin-fluctuation pairing and gap structures of iron-based superconductors</i>	<b>Physical Review B</b>	95		174504	10.1103/PhysRevB.95.174504
	Peprah, M.; VanGennep, D.; Quintero, P.; Risset, O.; Brinzari, T.; Li, C.; Dumont, M.; Xia, J.; Hamlin, J.; Tatham, D. and Meisel, M.,	<i>Photomagnetic response of heterostructured CoFe-CrCr-PBA core-shell nanoparticles</i>	<b>Am. Chem. Soc. Polyhedra</b>	123		323	10.1021/jacs.5b04303
	Martiny, J.H.J.; Kreisel, A.; Hirschfeld, P.J. and Andersen, B.M.,	<i>Robustness of Quasiparticle Interference Test for Sign-changing Gaps in Multiband Superconductors</i>	<b>Physical Review B</b>	95		184507	10.1103/PhysRevB.95.184507
	Zhao, E.W.; Maligal-Ganesh, R.; Xiao, C.; Goh, T.-W.; Qi, Z.; Pei, Y.; Hagelein-Weaver, H. E.; Huang, W. and Bowers, C.R.,	<i>Silica-Encapsulated Pt-Sn Intermetallic Nanoparticles: A Robust Catalytic Platform for Parahydrogen-Induced Polarization of Gases and Liquids</i>	<b>Angewandte Chemie International Edition</b>	56		3925-3929	10.1002/anie.201701314
	Kreisel, A.; Roemer, A.; Hirschfeld, P.J.; Eremin, I. and Andersen, B.M.,	<i>Superconducting phase diagram of the paramagnetic one-band Hubbard model</i>	<b>Journal of Superconductivity and Novel Magnetism</b>	30	1	85-89	10.1007/s10948-016-3758-x
	Choubey, P.; Kreisel, A.; Berlijn, T.; Andersen, B.M. and Hirschfeld, P.J.,	<i>Universality of scanning tunneling microscopy in cuprate superconductors</i>	<b>Physical Review B</b>	96		174523	https://doi.org/10.1103/PhysRevB.96.174523
	Li, A.J.; Zhu, X.; Rhodes, D.; Samouche, C.C.; Balicas, L. and Hebard, A.F.,	<i>Van der Waals Schottky barriers as interface probes of the correlation of chemical potential shifts with charge density wave formation in 1T-TiSe<sub>2</sub> and 2H-NbSe<sub>2</sub></i>	<b>Physical Review B</b>	96		125301	10.1103/PhysRevB.96.125301

## 6.15. Books, Chapters, Reviews and Other One-Time Publications (4)

Chekmenov, E.; Paulino, J.; Fu, R. and Cross, T.A., "Anisotropic and Isotropic Chemical Shift Perturbations from Solid State NMR Spectroscopy for Structural and Functional Biology", *Modern Magnetic Resonance*, 1-15, 2017.

Popovic, D., "Metal-Insulator Transition in Correlated Two-Dimensional Systems with Disorder", *chapter in "Strongly Correlated Electrons in Two Dimensions"*, edited by S. V. Kravchenko (Pan Stanford Publishing Pte. Ltd, Singapore), 2017.

Sanabria, C., "A new understanding of the heat treatment of Nb<sub>3</sub>Sn superconducting wires", *CreateSpace Independent Publishing Platform*, 2017.

Sullivan, N.S.; Tang, Y.; Parks, C. and Stachowiak, P., "NMR Studies of the Dynamics of <sup>3</sup>He on Boron Nitride", *Boron Nitride: Synthesis, Properties, Applications by NOVA Publishers*, 302-329, 2017.

## 6.16. Internet Disseminations (4)

Dobrosavljevic, V., *NHMFL 2017 Theory Winter School: "Modeling of Correlated Electron Materials: Materials Ge-*

# Chapter 6 – Accomplishments & Discoveries

*nome Meets High Magnetic Fields*", School Co-Organizer (with Laura Greene and Kevin Ingersent), <https://nationalmaglab.org/news-events/events/2017-theory-winter-school>, (Jan. 9-13 2017)

Li, J., *A transport study of emerging phenomena in bilayer graphene nanostructures*, <https://etda.libraries.psu.edu/catalog/14523jil5369>, (2017)

Ramshaw, B.J.; Modic, K.A.; Shekhter, A.; Moll, P.J.W.; Chan, M.K.; Betts, J.B.; Balakirev, F.; Migliori, A.; Ghimire, N.J.; Bauer, E.D.; Ronning, F. and McDonald, R.D., *Annihilation of Weyl nodes in the extreme quantum limit of TaAs* [arXiv], <https://arxiv.org/abs/1704.06944>, (April, 23 2017)

Sahoo, P.K.; Memaran, S.; Xin, Y.; Balicas, L. and Gutierrez, H.R., *Sequential Edge-Epitaxy in One-Pot Growth of 2D Lateral Heterostructures*, <https://arxiv.org/abs/1706.07014>, (2017)

## 6.17. Patents & Other Products (1)

Manning, T., *"Overcoming Resistance for Tuberculosis Antibiotics"*, Pub. #: 20160038422 (2017)

## 6.18. Awards, Honors, and Service (9)

Balicas, L., Research Professor - Physics Department - Florida State University (2017-present)

Boebinger, G., Fellow of the American Academy of Arts and Sciences (2017-present)

Dalal, N., Fellow of the Royal Society of Chemistry (2017-present)

Guo, W., Invitation Fellowships for Research in Japan (2017-2018)

Marshall, A., 2017 Florida Academy of Sciences Medalist (2017-present)

Niu, R., Best Poster Award for "Aging effect of Zylon" on MT 25 (2017)

Popovic, D., Outstanding Referee, American Physical Society (2017)

Popovic, D., Research Professor, Department of Physics, Florida State University (2017)

Zapf, Vivien, APS Fellow (2017)

## 6.19. Ph.D. Dissertations (local) (16)

Al-Awadhi, Fatma, *"Discovery and Characterization of Novel Anticancer and Antimetastatic Agents from Marine Cyanobacteria"*, University of Florida, Department of Medicinal Chemistry, advisor: Luesch, Hendrik (2017)

Arora, Harneet, *"Examination of Disease Progression in Upper and Lower Limb Muscles in Boys with DMD Using Functional Clinical Endpoints and Magnetic Resonance Imaging"*, University of Florida, Department of Physical

Therapy, advisor: Vandeborne, Krista (2017)

Batra, Abhinandan *"Non-Invasive monitoring of disease progression in Duchenne Muscular Dystrophy and Collagen 6 Myopathy"*, University of Florida, Department of Physical Therapy, advisor: Vandeborne, Krista (2017)

Cai, Weijing, *"Drug Discovery and Development of Natural Products from Marine Cyanobacteria as Anticancer Agents and Growth Factor Modulators"*, University of Florida, Department of Medicinal Chemistry, advisor: Luesch, Hendrik (2017)

Choubey, Peayush, *"Theoretical Visualization Of Atomic-Scale Phenomena Ininhomogeneous Superconductors"*, University of Florida, advisor: Hirschfeld, Peter (2017)

Downes, Daniel, *"An Integrated Approach for Detecting Metabolic Shifts in Response to Drug Administration and Disease by Magnetic Resonance Spectroscopy"*, University of Florida, Department of Biochemistry and Molecular Biology, advisor: Long, Joanna (2017)

Dutta, Akshita, *"Gas Diffusion in Strongly Confining and Interacting Microporous Sorbents by NMR"*, University of Florida, Department of Chemical Engineering, advisor: Vasenkov, Sergey (2017)

Gallagher, Andrew, *"Electronic Tuning in the Hidden Order Compound URu2Si2 through Si -> P Substitution"*, Florida State University, Physics, advisor: Baumbach, Ryan (2017)

Guang, Yue, *"Sensitive Spin Detection Using An On-Chip Squid-Waveguide Resonator"*, Florida State University, Physics Department, advisor: Chiorescu, Irinel (2017)

Hu, Xinbo, *"Studies On The Origins And Nature Of Critical Current Variations In Rare Earth Barium Copper Oxide Coated Conductors"*, Florida State University, Material Science and Engineering, advisor: Larbalestier, David (2017)

Normand, Anna, *"Global Peatland Soil Organic Carbon Chemical Composition and Greenhouse Gas Production"*, University of Florida, Soil and Water Sciences Department, advisor: Reddy, K.R. (2017)

Smeltz, Marci, *"Factors Modulating Dichloroacetate-Induced Glutathione Transferase Zeta 1 Inactivation in a Rat Model"*, University of Florida, Department of Medicinal Chemistry, advisor: Luesch, Hendrik (2017)

Wan, Lu, *"Imaging Human Brain Function in Single Individuals and Groups of Interacting Individuals"*, University of Florida, Department of Biomedical Engineering, advisor: Ding, Mingzhou (2017)

Wang, Yuting, *"Chemical Communication in Nematodes and Interactions with Microorganisms"*, University of

# Chapter 6 – Accomplishments & Discoveries

Florida, Department of Chemistry, advisor: Butcher, Rebecca (2017)

Yang, Shuying "*Mantle Source Compositions by LA-ICP-MS Analyses of Volcanic Glasses from Hawaii and the Mid-Oceanic Ridges.*", Florida State University; Earth, Ocean and Atmospheric Science, advisor: Humayun, Munir (2017)

Zhao, Evan Wenbo, "*Parahydrogen Induced Polarization by Heterogeneous Catalysis*", University of Florida, Department of Chemistry, advisor: Bowers, Clifford (2017)

## 6.20. Ph.D. Dissertations (external) (27)

Can, Thach, "*New methods for dynamic nuclear polarization in insulating solids: The Overhauser effect and time domain techniques*", Massachusetts Institute of Technology, Department of Chemistry, advisor: Griffin, Robert G. (2017)

Caulkins, Bethany, "*Enzymatic Intermediates of Tryptophan Synthase at Atomic Resolution Using Solid-State NMR*", University of California Riverside, Department of Chemistry, advisor: Mueller, Leonard (2017)

Escobar Bravo, Cristian Andres, "*Challenges in Characterizing Membrane Proteins and Intrinsically Disordered Regions Involved in Mycobacterium Tuberculosis Cell Division*", The Florida State University, Molecular Biophysics, advisor: Cross, Timothy (2017)

Gao, Jian, "*Visualization Study of Thermal Counterflow in Superfluid  $4\text{He}$* ", FSU, Mechanical Engineering Department, advisor: Guo, Wei (2017)

Hollinsworth, Brian, "*Optical Properties of Thin-Film High-Temperature Magnetic Ferrites*", University of Tennessee, Chemistry, advisor: Musfeldt, Jan (2017)

Hu, Xinbo, "*Studies On The Origins Of Critical Current Variations In Rare Earth Barium Copper Oxide Coated Conductors And Their Applications*", FSU, CoE, advisor: Larbalestier, David (2017)

Jiang, Tingting, "*Top-down and Middle-down Proteomics by Fourier Transform Ion Cyclotron Resonance Mass Spectrometry*", Florida University, Department of Chemistry, advisor: Marshall, Alan (2017)

Jiang, Yuxuan, "*Magneto-Infrared Spectroscopy of Emerging Topological Materials*", Georgia Institute of Technology, Physics, advisor: Jiang, Zhigang (2017)

Klotz, Johannes, "*Fermi-surface investigations of strongly correlated electron systems and  $\text{NbP}$* ", TU Dresden (Physics Department) / Helmholtz-Zentrum Dresden-Rossendorf (Hochfeldlabor), advisor: Wosnitza, Jochen (2017)

Klyueva, Maria, "*Features of synthesis and electron transport of single crystals of quasicrystalline phases and an approximant of the Al-Co-Cu-Fe system*", NUST MISIS, advisor: Shulyatev, Dmitriy (2017)

Lançon, Diane "*Neutron spectroscopy in the layered quantum magnet  $\text{SrCu}_2(\text{BO}_3)_2$  and in transition metal phosphorus trisulfides (MPS3)*", École Polytechnique Fédérale de Lausanne, Laboratory for Quantum Magnetism, advisor: Rønnow, Henrik (2017)

Lawson, Benjamin "*Search for Topological Superconductivity in Doped  $\text{Bi}_2\text{Se}_3$* ", Department of Physics, University of Michigan, advisor: Li, Lu (2017)

Liu, Jinyu, "*Quantum transport and magnetic properties in topological semimetals  $\text{AMnSb}_2$  ( $A=\text{Sr, Ba}$  and  $\text{Yb}$ )*", Tulane University, Department of Physics and Engineering Physics, advisor: Zhiqiang Mao (2017)

Maniv, Eran "*Probing the electronic structure of topological insulators and oxide interfaces*", Tel Aviv University, advisor: Dagan, Yoram (2017)

McCabe, Andrew, "*Photochemical Production of Reactive Intermediates in Inland Surface Waters University of Minnesota-Twin Cities*", University of Minnesota-Twin Cities, Department of Civil, Environmental, and Geo-Engineering, advisor: Arnold, A. William (2017)

Myhro, Kevin "*Electronic Properties of Suspended few-Layer Graphene Membranes*", University of California, Department of Physics and Astronomy, advisor: Lau, Chun Ning (Jeanie) (2017)

Premuzic, Dejan "*Neue homo- und heterometallische Komplexe von polydentaten Oximliganden*", Philipps University Marburg, Department of Chemistry, advisor: Holynska, Malgorzata (2017)

Ron, Alon "*Confined electrical transport in oxide interfaces*", Tel Aviv University, advisor: Dagan, Yoram (2017)

Roy, Rupsa, "*Geochemical study of mantle processes and paleoclimate reconstruction: perspective from mantle xenoliths and modern freshwater snail shells*", FSU, EOAS, advisor: Wang, Yang (2017)

Sanabria, Charlie; Larbalestier, David, "*A new understanding of the heat treatment of  $\text{Nb}_3\text{Sn}$  superconducting wires*", The Florida State University Materials Science and Engineering, advisor: Larbalestier, David (2017)

Semeniuk, Konstantin "*Correlated low temperature states of  $\text{YFe}_2\text{Ge}_2$  and pressure metallised  $\text{NiS}_2$* ", University of Cambridge, Cavendish Laboratory, advisor: Grosche, Malte (2017)

Tabatabai, Behnam, "*Biotechnological Approaches to*

# Chapter 6 – Accomplishments & Discoveries

*Enhance Halotolerance in Cyanobacterium, Fremyella Diplosiphon*", Morgan State University, Biology Department, advisor: Sither, Viji (2017)

Wilson, Douglas M., "NMR Investigation of the Layered Superconductor  $NbSe_2$ ", Materials Science and Engineering, advisor: Reyes, Arneil (2017)

Xin, Qiao, "Spherical self-assembly of Rous sarcoma virus, probed by solid state NMR and the structure of prostate acidic phosphatase and reflectin protein", University of Central Florida, Department of Physics, advisor: Chen, Bo (2017)

Yu, Fan "Torque Magnetometry Study of Under-doped  $YBa_2Cu_3O_y$ ", Department of Physics, University of Michigan, advisor: Li, Lu (2017)

Zhang, Po "Magnetotransport Studies of Fractional Quantum Hall Effect in High Mobility Two-Dimensional Hole System", Peking University, International Center

for Quantum Materials, advisor: Du, Rui-Rui (2017)

Zhou, Qiong "Transport Properties of Semimetallic Transition Metal Dichalcogenides", FSU - Physics Department, advisor: Balicas, Luis (2017)

## 6.21. Master Theses (3)

Bedford, "Review of Ferroic Thin Films and Devices With Proposed Experiments", Pennsylvania State University, Department of Physics, advisor: Li, Qi (2017)

McColaugh, Stephanie "Geochemistry of Greenland Ice Sheet Melt Water", Florida State University; Earth, Ocean and Atmospheric Science, advisor: Humayun, Munir (2017)

Singh, Prashant, "Isolation, Identification and Synthesis of Novel Compounds from an Entomopathogenic Nematode", University of Florida, Department of Chemistry, advisor: Butcher, Rebecca (2017)





# Final Report - No-Cost Extension

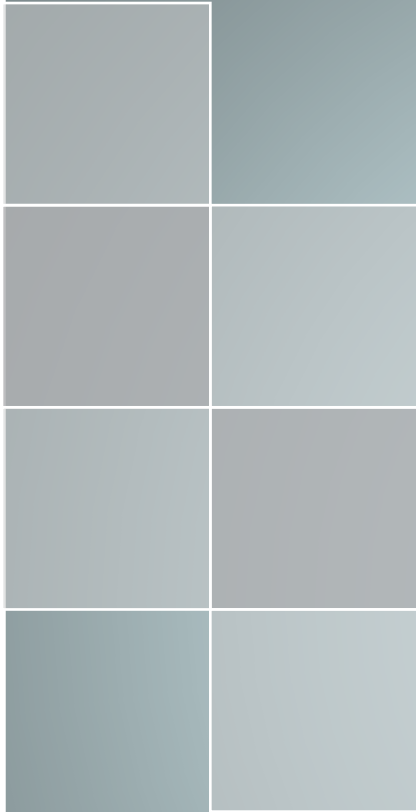

# Final Report – No-Cost Extension

The NHMFL has received a second no-cost extension to extend the amount of time for items that manufacturers had indicated that they could not deliver on time. The table below details those items while the paragraphs below provide the reasons that those items needed to be ordered and the impact of those items on the scientific productivity of the NHMFL in future years.

## RESISTIVE MAGNET PARTS

Bore Tube	13,490.00
Insulated Tie-rod, Obround	4,015.00
Insulator A2, Flat End 51.43 degree	105,905.66
Insulators for Magnets	9,375.00
Insulators for Magnets	555.00
Sheet Metal for Resistive Magnets	259,682.50
Resistive Magnet Disks - Disk B, CuZr, 0.45 thick	14,850.00
Resistive Magnet Disks - Disk B, CuZr, 0.77 thick, 0.44 Step	2,357.50
Resistive Magnet Disks - Disk B, CuZr, 0.77 thick, 0.44 Step	4,600.40
Silver Plating for Magnet Disks	6,972.00
Silver Plating of Magnet Disks	4,877.85
Silver Plating of Magnet Disks	13,954.84
Silver Plating of Magnet Disks	5,068.00

## Bi2212 SUPERCONDUCTIVE WIRE

Bi2212 bare superconductive wire	130,456.59
Bi2212 bare superconductive wire	53,233.41
Bi2212 braided superconductive wire	6,084.00

## 100T PULSED MAGNET - LANL

100 T Reinforced Shells	169,006.00
-------------------------	------------

## ADVANCED CYOGENIC SYSTEM FOR 41.5T

Complete 3 He/VTI Cryogenic systems include dewar for cryostats	392,300.00
---	------------

## DILUTION REFRIGERATOR FOR 32T SUPERCONDUCTING MAGNET SYSTEM

Dilution refrigerator for 32T superconducting magnet system	530,196.00
---	------------

## RESISTIVE MAGNET PARTS

The DC Facility is the largest and most heavily used facility of the entire NHMFL. Its workhorse magnets are its resistive magnets that consist of large sheets of high strength, high conductivity sheet metal (usually a copper alloy) that are stacked with insulators and high strength tie-rods to make strong compact coils. These coils have as many as 70 kiloamps running through them dissipating tens of megawatts of power. This power is carried away with thousands of gallons of deionized water that run through holes or slots stamped into the plates. This operation places the plates under tremendous stress and periodically wears the coils out. A major component of the MagLab's operation is stacking these coils and making sure that we have spare coils on hand for when the coils eventually fail. This ensures minimal downtime for a user as we can many times have a coil replaced in as little as 24 hours, provided we have spare coils on hand. However, the sheet metal is highly specialized and only available from select manufacturers. Since the MagLab orders are relatively small, many times there is a long lead-time until the manufacturer can find the space in its production schedule to retool their line and make the MagLabs sheet metal to its demanding specifications. Because of this long lead-time it is essential to order parts and sometimes those orders need to be ordered in one grant cycle in order to be used in another grant cycle.

# Final Report – No-Cost Extension

Such is the case for these parts. They were ordered but were not able to be delivered until after the normal grant cycle ended. This created the need for the no-cost extension to ensure uninterrupted scientific user operations in the DC facility.

## **Bi2212 SUPERCONDUCTIVE WIRE**

The MagLab is a world leader in innovating High Temperature Superconducting technology for use in next generation high field magnets. A leading candidate for these next generation magnets is Bi2212 Superconducting wire. This wire is highly specialized and the Applied Superconductivity Center division of the MagLab is working with the wire manufacturer to improve the wire and finding ways to make higher functioning coils using the wire. This long lead-time item was an essential purchase and the acquisition needed to be made when it did to ensure that the research effort at the MagLab continues to lead the world in its efforts to develop the best next generation high field magnets.

## **100T PULSED MAGNET – LANL**

The MagLab's Pulsed Field Facility at Los Alamos National Laboratory (LANL) uses high strength, high conductivity wire that is bent into coils and reinforced with highly specialized high strength stainless steel alloys. These reinforcing shells are extremely difficult to make as it is very difficult to machine them due to their extremely high strength properties. Because these coils make their very high magnetic fields by energizing the coils with what is essentially a lightning bolt of energy creating high magnetic fields that last for a split second, the coils are very highly stressed and eventually wear out due to metal fatigue. Because of this they need to be periodically removed from service and replaced before they explode creating great damage to the other coils in the magnet. These highly specialized coils are also long lead-time items and needed to be ordered during one grant cycle and delivered during the next to ensure uninterrupted user operations.

## **ADVANCED CRYOGENIC SYSTEM FOR 41.5T**

This advanced cryogenic system was ordered to be used in the world record 41.5T resistive magnet. The system consists of a Variable Temperature Insert that can deliver temperatures between room temperature and 1.2 degrees above absolute zero (1.2-300K) and a He-3 cryostat that can deliver temperatures between 0.5 degrees and 70 degrees above absolute zero (0.5-70K). These systems must be designed to fit into the narrow bore of the 41.5T magnet, be designed to be non-magnetic and with low conductance to be compatible with the magnet and are made with top loading probes to ensure the users of this magnet can quickly change samples to maximize the science they do while utilizing the magnet. These probes are also made to be compatible with both systems to maximize scientific productivity and minimize downtime. This system was ordered with a delivery time within the grant cycle, but it was delayed due to a serious injury to a highly specialized worker of the vendor making the cryostats

## **DILUTION REFRIGERATOR FOR 32T SUPERCONDUCTING MAGNET SYSTEM**

The 32T all superconducting magnet is a revolutionary step forward in the world of high field magnets. Before the MagLab began a huge expensive hybrid magnet was required to produce more than 30T continuously. These combinations of superconducting magnets on the outside with resistive magnets on the inside were very expensive and complicated using vast amounts of power. Now the 32T all superconducting magnet system is the first all superconducting user magnet to break the 30T barrier. It uses high temperature superconducting materials along with conventional low temperature superconductors. It is designed to be protected in a quench and will produce high quality very low noise. This makes this magnet an ideal environment to do research with the combination of low temperatures and very high fields. This dilution refrigerator is designed to operate at temperatures less than 20 thousandths of a degree above absolute zero (20mK). It is also top loading to ensure that users can change their samples quickly and provides minimum downtime. This system was procured with a delivery date within the normal grant cycle but repeated delays by the manufacturer forced the delivery during the second no-cost extension period.



# Appendix I – User Facility Statistics



# Appendix I – User Facility Statistics

AMRIS

AMRIS

## User Facilities

Seven user facilities — AMRIS (NMR-MRI@UF), DC Field, EMR, High B/T, ICR, NMR-MRI@FSU, and Pulsed Field — each with exceptional instrumentation and highly qualified staff scientists and staff, comprise the magnet lab’s user program. In this appendix, each facility presents detailed information about its user demographics, operations statistics and requests for magnet time.

A user is an individual or a member of a research group that is allocated magnet time. The user does not have to be “on site” for the experiment. A researcher who sends samples for analysis; a scientist who uses new lab technologies to conduct experiments remotely; or a PI who sends students to the magnet lab, are all considered users. All user numbers reflect distinct individuals, i.e. if a user has multiple proposals (different scientific thrusts) or is allocated magnet time more than once during the year, he/she is counted only once. All user data in the **user facility statistics is as of March 8, 2018.**

## 1. Advanced Magnetic Resonance Imaging and Spectroscopy (AMRIS)

**Table 1a: User Demographics-NSF-Funded**

AMRIS Facility	Users	Male	Female	Other	Prefer Not to Respond to Gender	Minority <sup>1</sup>	Non-Minority <sup>1</sup>	Prefer Not to Respond to Race	Users Present	Users Operating Remotely <sup>2</sup>	Users Sending Sample <sup>3</sup>	Off-Site Collaborators <sup>4</sup>
Senior Personnel, U.S.	43	21	7	0	15	4	32	7	14	0	0	29
Senior Personnel, non-U.S.	5	2	1	0	2	0	4	1	0	0	0	5
Postdocs, U.S.	10	4	5	0	1	1	9	0	6	0	0	4
Postdocs, non-U.S.	1	0	0	0	1	0	1	0	0	0	0	1
Students, U.S.	32	14	7	0	11	0	31	1	19	0	1	12
Students, non-U.S.	2	0	0	0	2	0	2	0	0	0	1	1
Technician, U.S.	6	2	2	0	2	0	5	1	5	0	0	1
Technician, non-U.S.	0	0	0	0	0	0	0	0	0	0	0	0
<b>Total:</b>	<b>99</b>	<b>43</b>	<b>22</b>	<b>0</b>	<b>34</b>	<b>5</b>	<b>84</b>	<b>10</b>	<b>44</b>	<b>0</b>	<b>2</b>	<b>53</b>

<sup>1.</sup> NSF Minority status includes the following races: American Indian, Alaska Native, Black or African American, Hispanic, Native Hawaiian or other Pacific Islander. The definition also includes Hispanic Ethnicity as a minority group. Minority status excludes Asian and White-Not of Hispanic Origin

<sup>2.</sup> “Users Operating Remotely” refers to users who operate the magnet system from a remote location. Remote operations are not currently available in all facilities.

<sup>3.</sup> “Users Sending Sample” refers to users who send the sample to the facility and/or research group and the experiment is conducted by other collaborators on the experiment. Users at UF, FSU, and LANL cannot be “sample senders” for facilities located on their campuses.

<sup>4.</sup> “Off-Site Collaborators” are scientific or technical participants on the experiment; who will not be present, sending sample, or operating the magnet system remotely; and who are not located on the campus of that facility (i.e., they are off-site).

Note: Users using multiple facilities are counted in each facility listed. AMRIS users involved in both NSF-funded projects and Non-NHMFL-Funded projects appear in both tables.

# Appendix I – User Facility Statistics

AMRIS

AMRIS

**Table 1b: User Demographics-Non-NHMFL-Funded**

AMRIS Facility	Users	Male	Female	Other	Prefer Not to Respond to Gender	Minority <sup>1</sup>	Non-Minority <sup>1</sup>	Prefer Not to Respond to Race	Users Present	Users Operating Remotely <sup>2</sup>	Users Sending Sample <sup>3</sup>	Off-Site Collaborators <sup>4</sup>
Senior Personnel, U.S.	90	35	12	0	43	4	79	7	85	0	1	4
Senior Personnel, non-U.S.	1	0	0	0	1	0	0	1	0	0	0	1
Postdocs, U.S.	34	13	11	0	10	4	26	4	28	0	0	6
Postdocs, non-U.S.	0	0	0	0	0	0	0	0	0	0	0	0
Students, U.S.	80	30	21	0	29	6	71	3	61	0	0	19
Students, non-U.S.	0	0	0	0	0	0	0	0	0	0	0	0
Technician, U.S.	35	6	12	0	17	5	29	1	26	0	1	8
Technician, non-U.S.	0	0	0	0	0	0	0	0	0	0	0	0
<b>Total:</b>	<b>240</b>	<b>84</b>	<b>56</b>	<b>0</b>	<b>100</b>	<b>19</b>	<b>205</b>	<b>16</b>	<b>200</b>	<b>0</b>	<b>2</b>	<b>38</b>

1. NSF Minority status includes the following races: American Indian, Alaska Native, Black or African American, Hispanic, Native Hawaiian or other Pacific Islander. The definition also includes Hispanic Ethnicity as a minority group. Minority status excludes Asian and White-Not of Hispanic Origin
2. “Users Operating Remotely” refers to users who operate the magnet system from a remote location. Remote operations are not currently available in all facilities.
3. “Users Sending Sample” refers to users who send the sample to the facility and/or research group and the experiment is conducted by other collaborators on the experiment. Users at UF, FSU, and LANL cannot be “sample senders” for facilities located on their campuses.
4. “Off-Site Collaborators” are scientific or technical participants on the experiment; who will not be present, sending sample, or operating the magnet system remotely; and who are not located on the campus of that facility (i.e., they are off-site).

Note: Users using multiple facilities are counted in each facility listed. AMRIS users involved in both NSF-funded projects and Non-NHMFL-Funded projects appear in both tables.

**Table 1c: User Demographics Summary**

AMRIS Facility	Users	Male	Female	Other	Prefer Not to Respond to Gender	Minority <sup>1</sup>	Non-Minority <sup>1</sup>	Prefer Not to Respond to Race	Users Present	Users Operating Remotely <sup>2</sup>	Users Sending Sample <sup>3</sup>	Off-Site Collaborators <sup>4</sup>
<b>NSF-Funded</b>	<b>99</b>	<b>43</b>	<b>22</b>	<b>0</b>	<b>34</b>	<b>5</b>	<b>84</b>	<b>10</b>	<b>44</b>	<b>0</b>	<b>2</b>	<b>53</b>
<b>Independently-Funded</b>	<b>240</b>	<b>84</b>	<b>56</b>	<b>0</b>	<b>100</b>	<b>19</b>	<b>205</b>	<b>16</b>	<b>200</b>	<b>0</b>	<b>2</b>	<b>38</b>
<b>Total</b>	<b>339</b>	<b>127</b>	<b>78</b>	<b>0</b>	<b>134</b>	<b>24</b>	<b>289</b>	<b>26</b>	<b>244</b>	<b>0</b>	<b>4</b>	<b>91</b>

1. NSF Minority status includes the following races: American Indian, Alaska Native, Black or African American, Hispanic, Native Hawaiian or other Pacific Islander. The definition also includes Hispanic Ethnicity as a minority group. Minority status excludes Asian and White-Not of Hispanic Origin
2. “Users Operating Remotely” refers to users who operate the magnet system from a remote location. Remote operations are not currently available in all facilities.
3. “Users Sending Sample” refers to users who send the sample to the facility and/or research group and the experiment is conducted by other collaborators on the experiment. Users at UF, FSU, and LANL cannot be “sample senders” for facilities located on their campuses.
4. “Off-Site Collaborators” are scientific or technical participants on the experiment; who will not be present, sending sample, or operating the magnet system remotely; and who are not located on the campus of that facility (i.e., they are off-site).

Note: Users using multiple facilities are counted in each facility listed. AMRIS users involved in both NSF-funded projects and Non-NHMFL-Funded projects appear in both tables.

# Appendix I – User Facility Statistics

AMRIS

AMRIS

**Table 2a: User Affiliation-NSF-Funded**

AMRIS Facility	Users	NHMFL-Affiliated Users <sup>1</sup>	Local Users <sup>1</sup>	University Users <sup>2,4</sup>	Industry Users <sup>4</sup>	National Lab Users <sup>3,4</sup>
Senior Personnel, U.S.	43	14	5	40	1	2
Senior Personnel, non-U.S.	5	0	0	5	0	0
Postdocs, U.S.	10	3	1	9	1	0
Postdocs, non-U.S.	1	0	0	1	0	0
Students, U.S.	32	0	11	32	0	0
Students, non-U.S.	2	0	0	2	0	0
Technician, U.S.	6	3	1	6	0	0
Technician, non-U.S.	0	0	0	0	0	0
<b>Total:</b>	<b>99</b>	<b>20</b>	<b>18</b>	<b>95</b>	<b>2</b>	<b>2</b>

<sup>1.</sup> NHMFL-Affiliated users are defined as anyone in the lab's personnel system [i.e. on our Web site/directory], even if they travel to another site. Local users are defined as any non-NHMFL-Affiliated researchers originating at any of the institutions in proximity to the MagLab sites (i.e. researchers at FSU, UF, FAMU, or LANL), even if they travel to another site.

<sup>2.</sup> The sum of NHMFL-Affiliated and Local users equals what was formerly referred to as "Internal Investigators".

<sup>3.</sup> In addition to external users, all users with primary affiliations at FSU, UF, or FAMU are reported in this category, even if they are also NHMFL associates.

<sup>4.</sup> In addition to external users, users with primary affiliations at NHMFL/LANL are reported in this category.

Note: The total of university, industry, and national lab users will equal the total number of users.

Users using multiple facilities are counted in each facility listed. AMRIS users involved in both NSF-funded projects and Non-NHMFL-Funded projects appear in both tables.

**Table 2b: User Affiliation-Non-NHMFL-Funded**

AMRIS Facility	Users	NHMFL-Affiliated Users <sup>1</sup>	Local Users <sup>1</sup>	University Users <sup>2,4</sup>	Industry Users <sup>4</sup>	National Lab Users <sup>3,4</sup>
Senior Personnel, U.S.	90	15	28	90	0	0
Senior Personnel, non-U.S.	1	0	0	1	0	0
Postdocs, U.S.	34	3	9	34	0	0
Postdocs, non-U.S.	0	0	0	0	0	0
Students, U.S.	80	0	34	80	0	0
Students, non-U.S.	0	0	0	0	0	0
Technician, U.S.	35	3	12	35	0	0
Technician, non-U.S.	0	0	0	0	0	0
<b>Total:</b>	<b>240</b>	<b>21</b>	<b>83</b>	<b>240</b>	<b>0</b>	<b>0</b>

<sup>1.</sup> NHMFL-Affiliated users are defined as anyone in the lab's personnel system [i.e. on our Web site/directory], even if they travel to another site. Local users are defined as any non-NHMFL-Affiliated researchers originating at any of the institutions in proximity to the MagLab sites (i.e. researchers at FSU, UF, FAMU, or LANL), even if they travel to another site.

<sup>2.</sup> The sum of NHMFL-Affiliated and Local users equals what was formerly referred to as "Internal Investigators".

<sup>3.</sup> In addition to external users, all users with primary affiliations at FSU, UF, or FAMU are reported in this category, even if they are also NHMFL associates.

<sup>4.</sup> In addition to external users, users with primary affiliations at NHMFL/LANL are reported in this category.

Note: The total of university, industry, and national lab users will equal the total number of users.

Users using multiple facilities are counted in each facility listed. AMRIS users involved in both NSF-funded projects and Non-NHMFL-Funded projects appear in both tables.

# Appendix I – User Facility Statistics

AMRIS

AMRIS

**Table 2c: User Affiliation Summary**

AMRIS Facility	Users	NHMFL-Affiliated Users <sup>1</sup>	Local Users <sup>1</sup>	University Users <sup>2,4</sup>	Industry Users <sup>4</sup>	National Lab Users <sup>3,4</sup>
NSF-Funded	99	20	18	95	2	2
Non-NHMFL-Funded	240	21	83	240	0	0
<b>Total</b>	<b>339</b>	<b>41</b>	<b>101</b>	<b>335</b>	<b>2</b>	<b>2</b>

<sup>1.</sup> NHMFL-Affiliated users are defined as anyone in the lab's personnel system [i.e. on our Web site/directory], even if they travel to another site. Local users are defined as any non-NHMFL-Affiliated researchers originating at any of the institutions in proximity to the MagLab sites (i.e. researchers at FSU, UF, FAMU, or LANL), even if they travel to another site.

<sup>2.</sup> The sum of NHMFL-Affiliated and Local users equals what was formerly referred to as "Internal Investigators".

<sup>3.</sup> In addition to external users, all users with primary affiliations at FSU, UF, or FAMU are reported in this category, even if they are also NHMFL associates.

<sup>4.</sup> In addition to external users, users with primary affiliations at NHMFL/LANL are reported in this category.

Note: The total of university, industry, and national lab users will equal the total number of users.

Users using multiple facilities are counted in each facility listed. AMRIS users involved in both NSF-funded projects and Non-NHMFL-Funded projects appear in both tables.

**Table 3a: User by Discipline-NSF-Funded**

AMRIS Facility	Users	Condensed Matter Physics	Chemistry, Geochemistry	Engineering	Magnets, Materials, Testing, Instrum.	Biology, Biochem, Biophys.
Senior Personnel, U.S.	43	2	8	6	0	27
Senior Personnel, non-U.S.	5	0	2	1	0	2
Postdocs, U.S.	10	0	2	1	1	6
Postdocs, non-U.S.	1	0	1	0	0	0
Students, U.S.	32	1	15	7	0	9
Students, non-U.S.	2	0	1	0	0	1
Technician, U.S.	6	0	0	3	1	2
Technician, non-U.S.	0	0	0	0	0	0
<b>Total:</b>	<b>99</b>	<b>3</b>	<b>29</b>	<b>18</b>	<b>2</b>	<b>47</b>

Note: Users using multiple facilities are counted in each facility listed. AMRIS users involved in both NSF-funded projects and Non-NHMFL-Funded projects appear in both tables.

**Table 3b: User by Discipline-Non-NHMFL-Funded**

AMRIS Facility	Users	Condensed Matter Physics	Chemistry, Geochemistry	Engineering	Magnets, Materials, Testing, Instrum.	Biology, Biochem, Biophys.
Senior Personnel, U.S.	90	0	15	3	4	68
Senior Personnel, non-U.S.	1	0	0	0	0	1
Postdocs, U.S.	34	0	4	3	2	25
Postdocs, non-U.S.	0	0	0	0	0	0
Students, U.S.	80	1	18	10	12	39
Students, non-U.S.	0	0	0	0	0	0
Technician, U.S.	35	0	0	1	6	28
Technician, non-U.S.	0	0	0	0	0	0
<b>Total:</b>	<b>240</b>	<b>1</b>	<b>37</b>	<b>17</b>	<b>24</b>	<b>161</b>

Note: Users using multiple facilities are counted in each facility listed. AMRIS users involved in both NSF-funded projects and Non-NHMFL-Funded projects appear in both tables.



# Appendix I – User Facility Statistics

AMRIS

AMRIS

**Table 3c: User by Discipline Summary**

AMRIS Facility	Users	Condensed Matter Physics	Chemistry, Geochemistry	Engineering	Magnets, Materials, Testing, Instrum.	Biology, Biochem, Biophys.
NSF-Funded	99	3	29	18	2	47
Non-NHMFL-Funded	240	1	37	17	24	161
<b>Total</b>	<b>339</b>	<b>4</b>	<b>66</b>	<b>35</b>	<b>26</b>	<b>208</b>

Note: Users using multiple facilities are counted in each facility listed. AMRIS users involved in both NSF-funded projects and Non-NHMFL-Funded projects appear in both tables.

**Table 4a: User Facility Operations-NSF-Funded**

AMRIS Facility	500 MHz NMR	600 MHz NMR warm bore	600 MHz cryo	600 MHz NMR (Agilent)	750 MHz whole body	4.7 T/ 33 cm	11.1 T/ 40 cm	Total Days Used	Percentage of Total Days Used
<b>Number of Magnet Days<sup>1</sup></b>									
NHMFL-Affiliated	16.35	3.5	12.99	13.57	0	38.08	5.33	<b>89.82</b>	7.99%
Local	0	0	0	0	0	0	0	<b>0</b>	0%
U.S. University	68.53	94	59.25	4.95	155.75	2.25	2.5	<b>387.23</b>	34.45%
U.S. Govt. Lab.	0	0	0	0	0	0	0	<b>0</b>	0%
U.S. Industry	0	0	0	0	0	0	0	<b>0</b>	0%
Non-U.S.	0.5	18.25	13.06	12.75	17.5	0	1	<b>63.07</b>	5.61%
Test, Calibration, Set-up, Maintenance, Inst. Dev.	41.62	75.25	99.7	86.73	43.75	98.67	138.17	<b>583.89</b>	51.95%
<b>Total:</b>	<b>127</b>	<b>191</b>	<b>185</b>	<b>118</b>	<b>217</b>	<b>139</b>	<b>147</b>	<b>1,124</b>	<b>100%</b>

<sup>1</sup> User Units are defined as magnet days; time utilized is recorded to the nearest 15 minutes. Magnet-day definitions for AMRIS instruments: Verticals (500, 600s, & 750 MHz), 1 magnet day = 24 hours. Horizontals (4.7, 11.1, and 3T), 1 magnet day = 8 hours. This accounts for the difficulty in running animal or human studies overnight. Magnet days were calculated by adding the total number of real used for each instrument and dividing by 24 (vertical) or 8 (horizontal). Note: Due to the nature of the 4.7 T, 11 T and 3 T studies, almost all studies with external users were collaborative with UF investigators. Beginning in 2014, imaging at 3T is funded entirely off of non-NHMFL funds.

**Table 4b: User Facility Operations-Non-NHMFL-Funded**

AMRIS Facility	500 MHz NMR	600 MHz NMR warm bore	600 MHz cryo	600 MHz NMR (Agilent)	750 MHz whole body	3T Phillips Whole Body	3T Siemens Whole Body	4.7T /33 cm	11.1T /40 cm	Total Days Used	Percentage of Total Days Used
<b>Number of Magnet Days<sup>1</sup></b>											
NHMFL-Affiliated	107	26	25.17	3	32	11.94	26.25	34	80.5	<b>345.85</b>	24.77%
Local	37.33	4	0.83	0.5	8.5	3.87	3.49	14	6.5	<b>79.03</b>	5.66%
U.S. University	16.67	72	119	152.5	56.5	232.42	162.71	27	37	<b>875.8</b>	62.74%
U.S. Govt. Lab.	0	0	0	0	0	0	0	0	0	<b>0</b>	0%
U.S. Industry	0	0	0	0	0	0	0	0	0	<b>0</b>	0%
Non-U.S.	0	0	0	0	0	0	0	0	0	<b>0</b>	0%
Test, Calibration, Set-up, Maintenance, Inst. Dev.	0	0	0	0	0	32.77	62.55	0	0	<b>95.32</b>	6.83%
<b>Total:</b>	<b>161</b>	<b>102</b>	<b>145</b>	<b>156</b>	<b>97</b>	<b>281</b>	<b>255</b>	<b>75</b>	<b>124</b>	<b>1,396</b>	<b>100%</b>

<sup>1</sup> User Units are defined as magnet days; time utilized is recorded to the nearest 15 minutes. Magnet-day definitions for AMRIS instruments: Verticals (500, 600s, & 750 MHz), 1 magnet day = 24 hours. Horizontals (4.7, 11.1, and 3T), 1 magnet day = 8 hours. This accounts for the difficulty in running animal or human studies overnight. Magnet days were calculated by adding the total number of real used for each instrument and dividing by 24 (vertical) or 8 (horizontal). Note: Due to the nature of the 4.7 T, 11 T and 3 T studies, almost all studies with external users were collaborative with UF investigators. Beginning in 2014, imaging at 3T is funded entirely off of non-NHMFL funds.

# Appendix I – User Facility Statistics

AMRIS

AMRIS

**Table 4c: User Facility Operations Summary**

AMRIS Facility	500 MHz NMR	600 MHz NMR warm bore	600 MHz cryo	600 MHz NMR (Agilent)	750 MHz whole body	3T Phillips Whole Body	3T Siemens Whole Body	4.7 T / 33 cm	11.1T/ 40 cm	Total Days Used	Percentage Total Days Used
<b>Number of Magnet Days<sup>1</sup></b>											
<b>NSF-Funded</b>	127	191	185	118	217	NA	NA	139	147	<b>1,124</b>	100%
<b>Non-NHMFL-Funded</b>	161	102	145	156	97	281	255	75	124	<b>1,396</b>	100%
<b>Total</b>	<b>288</b>	<b>293</b>	<b>330</b>	<b>274</b>	<b>314</b>	<b>281</b>	<b>255</b>	<b>214</b>	<b>271</b>	<b>2,520</b>	<b>100%</b>

<sup>1</sup> User Units are defined as magnet days; time utilized is recorded to the nearest 15 minutes. Magnet-day definitions for AMRIS instruments: Verticals (500, 600s, & 750 MHz), 1 magnet day = 24 hours. Horizontals (4.7, 11.1, and 3T), 1 magnet day = 8 hours. This accounts for the difficulty in running animal or human studies overnight. Magnet days were calculated by adding the total number of real used for each instrument and dividing by 24 (vertical) or 8 (horizontal). Note: Due to the nature of the 4.7 T, 11 T and 3 T studies, almost all studies with external users were collaborative with UF investigators. Beginning in 2014, imaging at 3T is funded entirely off of non-NHMFL funds.

**Table 5a: Operations by Discipline-NSF-Funded**

AMRIS Facility	Total Days Used	Condensed Matter Physics	Chemistry, Geochemistry	Engineering	Magnets, Materials, Testing, Instrum.	Biology, Biochem, Biophys.
<b>Number of Magnet Days<sup>1</sup></b>						
<b>NHMFL-Affiliated</b>	<b>89.81</b>	0	0	0	18.08	71.73
<b>Local</b>	<b>0</b>	0	0	0	0	0
<b>U.S. University</b>	<b>387.23</b>	0	79.17	136.25	0	171.81
<b>U.S. Govt. Lab.</b>	<b>0</b>	0	0	0	0	0
<b>U.S. Industry</b>	<b>0</b>	0	0	0	0	0
<b>Non-U.S.</b>	<b>63.07</b>	0	35.75	0	0	27.32
<b>Test, Calibration, Set-up, Maintenance, Inst. Dev.</b>	<b>583.89</b>	0	0	0	483.66	100.23
<b>Total:</b>	<b>1,124</b>	<b>0</b>	<b>114.92</b>	<b>136.25</b>	<b>501.74</b>	<b>371.09</b>

<sup>1</sup> User Units are defined as magnet days; time utilized is recorded to the nearest 15 minutes. Magnet-day definitions for AMRIS instruments: Verticals (500, 600s, & 750 MHz), 1 magnet day = 24 hours. Horizontals (4.7, 11.1, and 3T), 1 magnet day = 8 hours. This accounts for the difficulty in running animal or human studies overnight. Magnet days were calculated by adding the total number of real used for each instrument and dividing by 24 (vertical) or 8 (horizontal). Note: Due to the nature of the 4.7 T, 11 T and 3 T studies, almost all studies with external users were collaborative with UF investigators. Beginning in 2014, imaging at 3T is funded entirely off of non-NHMFL funds.

**Table 5b: Operations by Discipline-Non-NHMFL-Funded**

AMRIS Facility	Total Days Used	Condensed Matter Physics	Chemistry, Geochemistry	Engineering	Magnets, Materials, Testing, Instrum.	Biology, Biochem, Biophys.
<b>Number of Magnet Days<sup>1</sup></b>						
<b>NHMFL-Affiliated</b>	<b>345.85</b>	0	0	0	0	345.86
<b>Local</b>	<b>79.03</b>	0	12.5	0	0	66.53
<b>U.S. University</b>	<b>875.8</b>	0	13	31.5	0	831.3
<b>U.S. Govt. Lab.</b>	<b>0</b>	0	0	0	0	0
<b>U.S. Industry</b>	<b>0</b>	0	0	0	0	0
<b>Non-U.S.</b>	<b>0</b>	0	0	0	0	0
<b>Test, Calibration, Set-up, Maintenance, Inst. Dev.</b>	<b>95.32</b>	0	0	0	61.34	33.97
<b>Total:</b>	<b>1,396</b>	<b>0</b>	<b>25.5</b>	<b>31.5</b>	<b>61.34</b>	<b>1,277.66</b>

<sup>1</sup> User Units are defined as magnet days; time utilized is recorded to the nearest 15 minutes. Magnet-day definitions for AMRIS instruments: Verticals (500, 600s, & 750 MHz), 1 magnet day = 24 hours. Horizontals (4.7, 11.1, and 3T), 1 magnet day = 8 hours. This accounts for the difficulty in running animal or human studies overnight. Magnet days were calculated by adding the total number of real used for each instrument and dividing by 24 (vertical) or 8 (horizontal). Note: Due to the nature of the 4.7 T, 11 T and 3 T studies, almost all studies with external users were collaborative with UF investigators. Beginning in 2014, imaging at 3T is funded entirely off of non-NHMFL funds.

# Appendix I – User Facility Statistics

AMRIS

AMRIS

**Table 5c: Operations by Discipline Summary**

AMRIS Facility	Total Days Used	Condensed Matter Physics	Chemistry, Geochemistry	Engineering	Magnets, Materials, Testing, Instrum.	Biology, Biochem, Biophys.
<b>Number of Magnet Days<sup>1</sup></b>						
NSF-Funded	1,124	0	114.92	136.25	501.74	371.09
Non-NHMFL-Funded	1,396	0	25.5	31.5	61.34	1,277.66
<b>Total</b>	<b>2,520</b>	<b>0</b>	<b>140.4</b>	<b>167.8</b>	<b>563.1</b>	<b>1,648.8</b>

<sup>1</sup> User Units are defined as magnet days; time utilized is recorded to the nearest 15 minutes. Magnet-day definitions for AMRIS instruments: Verticals (500, 600s, & 750 MHz), 1 magnet day = 24 hours. Horizontals (4.7, 11.1, and 3T), 1 magnet day = 8 hours. This accounts for the difficulty in running animal or human studies overnight. Magnet days were calculated by adding the total number of real used for each instrument and dividing by 24 (vertical) or 8 (horizontal). Note: Due to the nature of the 4.7 T, 11 T and 3 T studies, almost all studies with external users were collaborative with UF investigators. Beginning in 2014, imaging at 3T is funded entirely off of non-NHMFL funds.

**Table 6a: User Program Experiment Pressure-NSF-Funded**

1. Experiments Submitted (Current Year)	2. Experiments Submitted (Deferred from Prev. Year)	3. Experiments with Usage	4. Experiments Submitted (Declined/Deferred to Next Year)	5. Experiments Reviewed	6. Subscription Rate
31	23	27 (50%)	27 (50%)	54	200%

**Table 6b: User Program Experiment Pressure-Non-NHMFL-Funded**

1. Experiments Submitted (Current Year)	2. Experiments Submitted (Deferred from Prev. Year)	3. Experiments with Usage	4. Experiments Submitted (Declined/Deferred to Next Year)	5. Experiments Reviewed	6. Subscription Rate
82	112	112 (57.73%)	82 (42.27%)	194	173.21%

**Table 6c: User Program Experiment Pressure Summary**

AMRIS Facility	Experiment Requests Received	Experiment Requests Deferred from Prev. Year	Experiment Requests Granted	Experiment Requests Declined/Deferred	Experiment Requests Reviewed	Subscription Rate
NSF-Funded	31	23	27 (50%)	27 (50%)	54	200%
Non-NHMFL-Funded	82	112	112 (57.73%)	82 (42.27%)	194	173.21%
<b>Total</b>	<b>113</b>	<b>135</b>	<b>139 (56%)</b>	<b>109 (44%)</b>	<b>248</b>	<b>178.4%</b>

**Table 7a: New User PIs-NSF-Funded**

Name	Organization	Proposal	Is New To MagLab
Agbandje-McKenna, Mavis	University of Florida	P02429	Yes
Bowman, Michael	University of Alabama, Tuscaloosa	P16066	Yes
Ding, Yousong	University of Florida	P16196	No
Gatto, Rodolfo	University of Illinois at Chicago	P17430	Yes
Harris, David	Northwestern University	P16314	Yes
Huigens, Robert	University of Florida	P16046	Yes
Mareci, Thomas	University of Florida	P16132	No
Maurer, Andrew	University of Florida	P16198	Yes
Salvador, Lilibeth	University of the Philippines	P16297	Yes
Tomitaka, Asahi	Florida International University	P17422	Yes
Vardanyan, Lilit	University of Florida	P16145	Yes
<b>Total: 11</b>			

Note: PIs who received magnet time for the first time.

# Appendix I – User Facility Statistics

AMRIS

AMRIS

**Table 7b: New User PI's-Non-NHMFL-Funded**

Name	Organization	Proposal	Is New To MagLab
Aldrich, Jane	University of Florida	P17397	Yes
Castellano, Ronald	University of Florida	P17412	Yes
Cousins, Robert	University of Florida	P17587	Yes
Greening, Alex	University of Florida	P17401	Yes
Guo, Zhongwu	University of Florida	P17400	Yes
Horenstein, Nicole	University of Florida	P17611	Yes
Li, Chenglong	University of Florida	P17612	Yes
McCurdy, Christopher	University of Florida	P17613	Yes
Mitchell, Duane	University of Florida	P17403	Yes
Nixon, Sara	University of Florida	P17393	Yes
Philmus, Benjamin	Oregon State University	P17394	Yes
Riley, Joseph	University of Florida	P17395	Yes
Schmidt, Christine	University of Florida	P17396	Yes
Smith, Glenn	University of Florida	P17618	Yes
Tran, David	University of Florida	P17405	Yes
Wynn, James	University of Florida	P17407	Yes
Xing, Chengguo	University of Florida	P17616	Yes

**Total: 17**

Note: PIs who received magnet time for the first time.

**Table 8a: Research Proposal<sup>1</sup> Profile with Magnet Time-NSF-Funded**

AMRIS Facility	Total	Minority <sup>2</sup>	Female <sup>3</sup>	Condensed Matter Physics	Chemistry, Geochemistry	Engineering	Magnets, Materials, Testing, Instrum.	Biology, Biochem., Biophys.
Number of Proposals <sup>1</sup>	27	3	10	0	6	3	0	18

1. A "proposal" may have associated with it a single experiment or a group of closely related experiments. A PI may have more than one proposal.
2. The number of proposals satisfying one of the following two conditions: (a) the PI is a minority OR (b) the PI is a non-minority working at a minority-serving college or university AND the proposal includes minority participants.
3. The number of proposals satisfying one of the following two conditions: (a) the PI is a female OR (b) the PI is a male working at a college or university for women AND the proposal includes female participants.

**Table 8b: Research Proposal<sup>1</sup> Profile with Magnet Time-Non-NHMFL-Funded**

AMRIS Facility	Total	Condensed Matter Physics	Chemistry, Geochemistry	Engineering	Magnets, Materials, Testing, Instrum.	Biology, Biochem., Biophys.
Number of Proposals <sup>1</sup>	111	0	0	0	0	111

1. A "proposal" may have associated with it a single experiment or a group of closely related experiments. A PI may have more than one proposal.
2. The number of proposals satisfying one of the following two conditions: (a) the PI is a minority OR (b) the PI is a non-minority working at a minority-serving college or university AND the proposal includes minority participants.
3. The number of proposals satisfying one of the following two conditions: (a) the PI is a female OR (b) the PI is a male working at a college or university for women AND the proposal includes female participants.

**Find the list of AMRIS user proposals in Appendix VI**

# Appendix I – User Facility Statistics

DC Field

DC Field

## 2. DC Field Facility

**Table 1: User Demographics**

DC Field Facility	Users	Male	Female	Other	Prefer Not to Respond to Gender	Minority <sup>1</sup>	Non-Minority <sup>1</sup>	Prefer Not to Respond to Race	Users Present	Users Operating Remotely <sup>2</sup>	Users Sending Sample <sup>3</sup>	Off-Site Collaborators <sup>4</sup>
Senior Personnel, U.S.	175	136	24	0	15	5	161	9	60	0	16	99
Senior Personnel, non-U.S.	81	65	9	0	7	4	73	4	15	0	11	55
Postdocs, U.S.	62	50	8	0	4	5	56	1	51	0	1	10
Postdocs, non-U.S.	24	17	3	0	4	0	20	4	14	0	0	10
Students, U.S.	181	133	24	0	24	5	166	10	144	0	6	31
Students, non-U.S.	53	43	7	0	3	1	46	6	35	0	1	17
Technician, U.S.	6	5	1	0	0	1	5	0	6	0	0	0
Technician, non-U.S.	1	1	0	0	0	0	1	0	0	0	0	1
<b>Total:</b>	<b>583</b>	<b>450</b>	<b>76</b>	<b>0</b>	<b>57</b>	<b>21</b>	<b>528</b>	<b>34</b>	<b>325</b>	<b>0</b>	<b>35</b>	<b>223</b>

1. NSF Minority status includes the following races: American Indian, Alaska Native, Black or African American, Hispanic, Native Hawaiian or other Pacific Islander. The definition also includes Hispanic Ethnicity as a minority group. Minority status excludes Asian and White-Not of Hispanic Origin
2. "Users Operating Remotely" refers to users who operate the magnet system from a remote location. Remote operations are not currently available in all facilities.
3. "Users Sending Sample" refers to users who send the sample to the facility and/or research group and the experiment is conducted by other collaborators on the experiment. Users at UF, FSU, and LANL cannot be "sample senders" for facilities located on their campuses.
4. "Off-Site Collaborators" are scientific or technical participants on the experiment; who will not be present, sending sample, or operating the magnet system remotely; and who are not located on the campus of that facility (i.e., they are off-site).

Note: Users using multiple facilities are counted in each facility listed.

**Table 2: User Affiliation**

DC Field Facility	Users	NHMFL-Affiliated Users <sup>1</sup>	Local Users <sup>1</sup>	University Users <sup>2,4</sup>	Industry Users <sup>4</sup>	National Lab Users <sup>3,4</sup>
Senior Personnel, U.S.	175	53	8	149	2	24
Senior Personnel, non-U.S.	81	0	0	60	2	19
Postdocs, U.S.	62	9	4	54	0	8
Postdocs, non-U.S.	24	0	0	17	0	7
Students, U.S.	181	12	12	177	0	4
Students, non-U.S.	53	0	0	49	0	4
Technician, U.S.	6	6	0	6	0	0
Technician, non-U.S.	1	0	0	1	0	0
<b>Total:</b>	<b>583</b>	<b>80</b>	<b>24</b>	<b>513</b>	<b>4</b>	<b>66</b>

1. NHMFL-Affiliated users are defined as anyone in the lab's personnel system [i.e. on our Web site/directory], even if they travel to another site. Local users are defined as any non-NHMFL-Affiliated researchers originating at any of the institutions in proximity to the MagLab sites (i.e. researchers at FSU, UF, FAMU, or LANL), even if they travel to another site.
2. The sum of NHMFL-Affiliated and Local users equals what was formerly referred to as "Internal Investigators".
3. In addition to external users, all users with primary affiliations at FSU, UF, or FAMU are reported in this category, even if they are also NHMFL associates.
4. In addition to external users, users with primary affiliations at NHMFL/LANL are reported in this category.

Note: The total of university, industry, and national lab users will equal the total number of users.

Users using multiple facilities are counted in each facility listed.

# Appendix I – User Facility Statistics

DC Field

DC Field

**Table 3: User by Discipline**

DC Field Facility	Users	Condensed Matter Physics	Chemistry, Geochemistry	Engineering	Magnets, Materials, Testing, Instrum.	Biology, Biochem, Biophys.
Senior Personnel, U.S.	175	119	10	20	11	15
Senior Personnel, non-U.S.	81	62	4	5	6	4
Postdocs, U.S.	62	53	1	2	2	4
Postdocs, non-U.S.	24	19	3	2	0	0
Students, U.S.	181	153	8	18	2	0
Students, non-U.S.	53	46	0	4	2	1
Technician, U.S.	6	0	0	1	5	0
Technician, non-U.S.	1	0	0	1	0	0
<b>Total:</b>	<b>583</b>	<b>452</b>	<b>26</b>	<b>53</b>	<b>28</b>	<b>24</b>

Note: Users using multiple facilities are counted in each facility listed.

**Table 4: User Facility Operations**

DC Field Facility	Resistive Magnets & Hybrid	Superconducting Magnets	Total Days Used	Percentage of Total Days Used
<b>Number of Magnet Days<sup>1</sup></b>				
NHMFL-Affiliated	160.15	211	<b>371.15</b>	20.84%
Local	0	35	<b>35</b>	1.97%
U.S. University	360.44	521	<b>881.44</b>	49.50%
U.S. Govt. Lab.	36.06	57	<b>93.06</b>	5.23%
U.S. Industry	0	7	<b>7</b>	0.39%
Non-U.S.	183.08	134	<b>317.08</b>	17.81%
Test, Calibration, Set-up, Maintenance, Inst. Dev.	48.85	27	<b>75.85</b>	4.26%
<b>Total:</b>	<b>788.58</b>	<b>992</b>	<b>1,780.58</b>	<b>100%</b>

<sup>1</sup> Each 20 MW resistive magnet requires two power supplies to run, the 45 T hybrid magnet requires three power supplies and the 36 T Series Connected Hybrid requires one power supply. Thus there can be four resistive magnets + three superconducting magnets operating or the 45 T hybrid, series connected hybrid, two resistive magnets and three superconducting magnets. User Units are defined as magnet days. Users of water-cooled resistive or hybrid magnets can typically expect to receive enough energy for 7 hours a day of magnet usage so a magnet day is defined as 7 hours. Superconducting magnets are scheduled typically 24 hours a day. There is an annual four week shutdown in fall of powered DC resistive and hybrid magnets for infrastructure maintenance and a two week shutdown period for the university mandated holiday break.

# Appendix I – User Facility Statistics

DC Field

DC Field

**Table 5: Operations by Discipline**

DC Field Facility	Total Days Used	Condensed Matter Physics	Chemistry, Geochemistry	Engineering	Magnets, Materials, Testing, Instrum.	Biology, Biochem, Biophys.
		<b>Number of Magnet Days<sup>1</sup></b>				
NHMFL-Affiliated	371.15	289.28	3.56	0	78.31	0
Local	35	21	14	0	0	0
U.S. University	881.44	813.17	32.41	21	12.95	1.9
U.S. Govt. Lab.	93.06	93.06	0	0	0	0
U.S. Industry	7	0	0	7	0	0
Non-U.S.	317.08	276.11	11.16	14	15.8	0
Test, Calibration, Set-up, Maintenance, Inst. Dev.	75.85	20	0	0	55.85	0
<b>Total:</b>	<b>1,780.58</b>	<b>1,512.62</b>	<b>61.13</b>	<b>42</b>	<b>162.91</b>	<b>1.9</b>

<sup>1</sup> Each 20 MW resistive magnet requires two power supplies to run, the 45 T hybrid magnet requires three power supplies and the 36 T Series Connected Hybrid requires one power supply. Thus there can be four resistive magnets + three superconducting magnets operating or the 45 T hybrid, series connected hybrid, two resistive magnets and three superconducting magnets. User Units are defined as magnet days. Users of water-cooled resistive or hybrid magnets can typically expect to receive enough energy for 7 hours a day of magnet usage so a magnet day is defined as 7 hours. Superconducting magnets are scheduled typically 24 hours a day. There is an annual four week shutdown in fall of powered DC resistive and hybrid magnets for infrastructure maintenance and a two week shutdown period for the university mandated holiday break.

**Table 6: User Program Experiment Pressure**

1. Experiments Submitted (Current Year)	2. Experiments Submitted (Deferred from Prev. Year)	3. Experiments with Usage	4. Experiments Submitted (Declined/Deferred to Next Year)	5. Experiments Reviewed	6. Subscription Rate
411	118	301 (56.9%)	228 (43.1%)	529	175.75%

**Table 7: New User PI's**

Name	Organization	Proposal	Is New To MagLab
Baenitz, Michael	Max Planck Institute for Chemical Physics of Solids, Dresden, Germany	P13638	No
Chen, Zhiguo	Institute of Physics, Chinese Academy of Sciences	P15997	Yes
Coniglio, William	National High Magnetic Field Laboratory (NHMFL)	P16001	Yes
Deshpande, Vikram	University of Utah	P16093	Yes
Drichko, Natalia	Johns Hopkins University	P16105	Yes
Green, Elizabeth	Helmholtz-Zentrum Dresden-Rossendorf	P17353	Yes
Grockowiak, Audrey	National High Magnetic Field Laboratory (NHMFL)	P16109	Yes
Halbedel, Bernd	Technische Universität Ilmenau	P17347	Yes
Hasan, Zahid	Princeton University	P16269	Yes
Jena, Debdeep	Cornell University	P16094	Yes
Jin, Rongying	Louisiana State University	P16257	Yes
Lai, Bo-Kuai	Lake Shore Cryotronics	P16121	Yes
Lee, Cheol Eui	Korea University	P16259	Yes
Ozerov, Mykhaylo	National High Magnetic Field Laboratory (NHMFL)	P17373	Yes
Pasupathy, Abhay	Columbia University	P16099	Yes
Patel, Anup	University of Cambridge	P16260	Yes
Podlesnyak, Andrey	Oak Ridge National Laboratory	P16097	Yes
Ramshaw, Brad	Cornell University	P02488	No

# Appendix I – User Facility Statistics

DC Field

DC Field

Name	Organization	Proposal	Is New To MagLab
Ross, Kate	Colorado State University	P16064	No
Shehter, Arkady	National High Magnetic Field Laboratory (NHMFL)	P01787	No
Shi, Xiaoyan	University of Texas, Dallas	P16252	Yes
Talbayev, Diyar	Tulane University	P12572	Yes
Usoskin, Alexander	Bruker HTS GmbH	P16288	Yes
Wei, Jiang	Tulane University	P16092	Yes
Yan, Jun	University of Massachusetts	P13659	Yes
Zherlitsyn, Sergei	Helmholtz-Zentrum Dresden-Rossendorf	P16103	Yes
<b>Total: 26</b>			

Note: PIs who received magnet time for the first time.

**Table 8: Research Proposal<sup>1</sup> Profile with Magnet Time**

DC Field Facility	Total	Minority <sup>2</sup>	Female <sup>3</sup>	Condensed Matter Physics	Chemistry, Geochemistry	Engineering	Magnets, Materials, Testing, Instrum.	Biology, Biochem., Biophys.
Number of Proposals <sup>1</sup>	164	5	25	139	7	5	11	2

<sup>1.</sup> A "proposal" may have associated with it a single experiment or a group of closely related experiments. A PI may have more than one proposal.

<sup>2.</sup> The number of proposals satisfying one of the following two conditions: (a) the PI is a minority OR (b) the PI is a non-minority working at a minority-serving college or university AND the proposal includes minority participants.

<sup>3.</sup> The number of proposals satisfying one of the following two conditions: (a) the PI is a female OR (b) the PI is a male working at a college or university for women AND the proposal includes female participants.

**Find the list of DC Field user proposals in Appendix VI**



# Appendix I – User Facility Statistics

EMR

EMR

## 3. EMR Facility

**Table 1: User Demographics**

EMR Facility	Users	Male	Female	Other	Prefer Not to Respond to Gender	Minority <sup>1</sup>	Non-Minority <sup>1</sup>	Prefer Not to Respond to Race	Users Present	Users Operating Remotely <sup>2</sup>	Users Sending Sample <sup>3</sup>	Off-Site Collaborators <sup>4</sup>
Senior Personnel, U.S.	62	48	7	0	7	4	51	7	19	0	2	41
Senior Personnel, non-U.S.	26	16	5	0	5	5	19	2	1	0	1	24
Postdocs, U.S.	15	13	2	0	0	1	13	1	6	0	5	4
Postdocs, non-U.S.	3	3	0	0	0	0	3	0	0	0	0	3
Students, U.S.	50	24	20	0	6	6	40	4	38	0	4	8
Students, non-U.S.	7	5	2	0	0	1	6	0	3	0	1	3
Technician, U.S.	1	1	0	0	0	0	1	0	1	0	0	0
Technician, non-U.S.	1	1	0	0	0	0	1	0	0	0	0	1
<b>Total:</b>	<b>165</b>	<b>111</b>	<b>36</b>	<b>0</b>	<b>18</b>	<b>17</b>	<b>134</b>	<b>14</b>	<b>68</b>	<b>0</b>	<b>13</b>	<b>84</b>

<sup>1</sup> NSF Minority status includes the following races: American Indian, Alaska Native, Black or African American, Hispanic, Native Hawaiian or other Pacific Islander. The definition also includes Hispanic Ethnicity as a minority group. Minority status excludes Asian and White-Not of Hispanic Origin

<sup>2</sup> “Users Operating Remotely” refers to users who operate the magnet system from a remote location. Remote operations are not currently available in all facilities.

<sup>3</sup> “Users Sending Sample” refers to users who send the sample to the facility and/or research group and the experiment is conducted by other collaborators on the experiment. Users at UF, FSU, and LANL cannot be “sample senders” for facilities located on their campuses.

<sup>4</sup> “Off-Site Collaborators” are scientific or technical participants on the experiment; who will not be present, sending sample, or operating the magnet system remotely; and who are not located on the campus of that facility (i.e., they are off-site).

Note: Users using multiple facilities are counted in each facility listed.

**Table 2: User Affiliation**

EMR Facility	Users	NHMFL-Affiliated Users <sup>1</sup>	Local Users <sup>1</sup>	University Users <sup>2,4</sup>	Industry Users <sup>4</sup>	National Lab Users <sup>3,4</sup>
Senior Personnel, U.S.	62	18	2	60	0	2
Senior Personnel, non-U.S.	26	1	0	19	0	7
Postdocs, U.S.	15	2	2	13	1	1
Postdocs, non-U.S.	3	0	0	3	0	0
Students, U.S.	50	6	9	50	0	0
Students, non-U.S.	7	0	0	7	0	0
Technician, U.S.	1	0	0	1	0	0
Technician, non-U.S.	1	0	0	1	0	0
<b>Total:</b>	<b>165</b>	<b>27</b>	<b>13</b>	<b>154</b>	<b>1</b>	<b>10</b>

<sup>1</sup> NHMFL-Affiliated users are defined as anyone in the lab’s personnel system [i.e. on our Web site/directory], even if they travel to another site. Local users are defined as any non-NHMFL-Affiliated researchers originating at any of the institutions in proximity to the MagLab sites (i.e. researchers at FSU, UF, FAMU, or LANL), even if they travel to another site.

<sup>2</sup> The sum of NHMFL-Affiliated and Local users equals what was formerly referred to as “Internal Investigators”.

<sup>3</sup> In addition to external users, all users with primary affiliations at FSU, UF, or FAMU are reported in this category, even if they are also NHMFL associates.

<sup>4</sup> In addition to external users, users with primary affiliations at NHMFL/LANL are reported in this category.

Note: The total of university, industry, and national lab users will equal the total number of users.

Users using multiple facilities are counted in each facility listed.

# Appendix I – User Facility Statistics

EMR

EMR

**Table 3: User by Discipline**

EMR Facility	Users	Condensed Matter Physics	Chemistry, Geochemistry	Engineering	Magnets, Materials, Testing, Instrum.	Biology, Biochem, Biophys.
Senior Personnel, U.S.	62	21	20	3	0	18
Senior Personnel, non-U.S.	26	5	17	0	1	3
Postdocs, U.S.	15	6	2	1	0	6
Postdocs, non-U.S.	3	1	1	0	1	0
Students, U.S.	50	13	26	1	4	6
Students, non-U.S.	7	2	4	0	1	0
Technician, U.S.	1	1	0	0	0	0
Technician, non-U.S.	1	0	1	0	0	0
<b>Total:</b>	<b>165</b>	<b>49</b>	<b>71</b>	<b>5</b>	<b>7</b>	<b>33</b>

Note: Users using multiple facilities are counted in each facility listed.

**Table 4: User Facility Operations**

EMR Facility	17T	12T	Mossbauer	Bruker	HiPER	Total Days Used	Percentage of Total Days Used
<b>Number of Magnet Days<sup>1</sup></b>							
NHMFL-Affiliated	40	78.5	78	78.5	88.5	<b>363.5</b>	32.46%
Local	0	0	0	22	0	<b>22</b>	1.96%
U.S. University	116	55.5	28	161	126.5	<b>487</b>	43.48%
U.S. Govt. Lab.	2	3	0	0	0	<b>5</b>	0.45%
U.S. Industry	0	0	0	0	0	<b>0</b>	0%
Non-U.S.	140	40	0	26	23	<b>229</b>	20.44%
Test, Calibration, Set-up, Maintenance, Inst. Dev.	13	0	0	0.5	0	<b>13.5</b>	1.21%
<b>Total:</b>	<b>311</b>	<b>177</b>	<b>106</b>	<b>288</b>	<b>238</b>	<b>1,120</b>	<b>100%</b>

<sup>1</sup> User Units are defined as magnet days. One magnet day is defined as 24 hours in superconducting magnets.

**Table 5: Operations by Discipline**

EMR Facility	Total Days Used	Condensed Matter Physics	Chemistry, Geochemistry	Engineering	Magnets, Materials, Testing, Instrum.	Biology, Biochem, Biophys.
<b>Number of Magnet Days<sup>1</sup></b>						
NHMFL-Affiliated	<b>363.5</b>	73	9	0	141.5	140
Local	<b>22</b>	0	21	0	0	1
U.S. University	<b>487</b>	60	157	0	23.5	246.5
U.S. Govt. Lab.	<b>5</b>	5	0	0	0	0
U.S. Industry	<b>0</b>	0	0	0	0	0
Non-U.S.	<b>229</b>	76	123	0	19	11
Test, Calibration, Set-up, Maintenance, Inst. Dev.	<b>13.5</b>	0	0	0	13	0.5
<b>Total:</b>	<b>1,120</b>	<b>214</b>	<b>310</b>	<b>0</b>	<b>197</b>	<b>399</b>

<sup>1</sup> User Units are defined as magnet days. One magnet day is defined as 24 hours in superconducting magnets.

# Appendix I – User Facility Statistics

EMR

EMR

**Table 6: User Program Experiment Pressure**

1. Experiments Submitted (Current Year)	2. Experiments Submitted (Deferred from Prev. Year)	3. Experiments with Usage	4. Experiments Submitted (Declined/Deferred to Next Year)	5. Experiments Reviewed	6. Subscription Rate
151	23	153 (87.93%)	21 (12.07%)	174	113.73%

**Table 7: New User PI's**

Name	Organization	Proposal	Is New To MagLab
Balicas, Luis	National High Magnetic Field Laboratory (NHMFL)	P00630	No
Enders, Markus	Heidelberg University	P17384	Yes
Hoffman, Brian	Northwestern University	P17350	Yes
Koruza, Jurij	Technical University of Darmstadt	P16240	Yes
Maier, Russell	National Institute of Standards and Technology	P17488	Yes
Mentink, Frederic	National High Magnetic Field Laboratory (NHMFL)	P16032	No
Reimer, Jeffrey	University of California, Berkeley	P17340	Yes
Shafaat, Hannah	Ohio State University	P17478	Yes
Shi, Sufei	Rensselaer Polytechnic Institute	P14775	No
Thirunavukkuarasu, Komalavalli	National High Magnetic Field Laboratory (NHMFL)	P17534	Yes
Witwicki, Maciej	University of Wroclaw	P17418	Yes
Yang, Fengyuan	Ohio State University	P02046	No
<b>Total: 12</b>			

Note: PIs who received magnet time for the first time.

**Table 8: Research Proposal<sup>1</sup> Profile with Magnet Time**

EMR Facility	Total	Minority <sup>2</sup>	Female <sup>3</sup>	Condensed Matter Physics	Chemistry, Geochemistry	Engineering	Magnets, Materials, Testing, Instrum.	Biology, Biochem, Biophys.
Number of Proposals <sup>1</sup>	61	4	9	16	19	1	7	18

<sup>1.</sup> A "proposal" may have associated with it a single experiment or a group of closely related experiments. A PI may have more than one proposal.

<sup>2.</sup> The number of proposals satisfying one of the following two conditions: (a) the PI is a minority OR (b) the PI is a non-minority working at a minority-serving college or university AND the proposal includes minority participants.

<sup>3.</sup> The number of proposals satisfying one of the following two conditions: (a) the PI is a female OR (b) the PI is a male working at a college or university for women AND the proposal includes female participants.

**Find the list of EMR user proposals in Appendix VI**

# Appendix I – User Facility Statistics

HBT

HBT

## 4. High B/T Facility

**Table 1: User Demographics**

High B/T Facility	Users	Male	Female	Other	Prefer Not to Respond to Gender	Minority <sup>1</sup>	Non-Minority <sup>1</sup>	Prefer Not to Respond to Race	Users Present	Users Operating Remotely <sup>2</sup>	Users Sending Sample <sup>3</sup>	Off-Site Collaborators <sup>4</sup>
Senior Personnel, U.S.	7	6	0	0	1	0	6	1	2	0	2	3
Senior Personnel, non-U.S.	4	2	1	0	1	0	4	0	1	0	0	3
Postdocs, U.S.	3	2	0	0	1	0	2	1	3	0	0	0
Postdocs, non-U.S.	2	1	1	0	0	0	2	0	2	0	0	0
Students, U.S.	3	2	0	0	1	0	3	0	2	0	0	1
Students, non-U.S.	1	0	0	0	1	0	1	0	0	0	0	1
Technician, U.S.	0	0	0	0	0	0	0	0	0	0	0	0
Technician, non-U.S.	0	0	0	0	0	0	0	0	0	0	0	0
<b>Total:</b>	<b>20</b>	<b>13</b>	<b>2</b>	<b>0</b>	<b>5</b>	<b>0</b>	<b>18</b>	<b>2</b>	<b>10</b>	<b>0</b>	<b>2</b>	<b>8</b>

<sup>1</sup> NSF Minority status includes the following races: American Indian, Alaska Native, Black or African American, Hispanic, Native Hawaiian or other Pacific Islander. The definition also includes Hispanic Ethnicity as a minority group. Minority status excludes Asian and White-Not of Hispanic Origin

<sup>2</sup> “Users Operating Remotely” refers to users who operate the magnet system from a remote location. Remote operations are not currently available in all facilities.

<sup>3</sup> “Users Sending Sample” refers to users who send the sample to the facility and/or research group and the experiment is conducted by other collaborators on the experiment. Users at UF, FSU, and LANL cannot be “sample senders” for facilities located on their campuses.

<sup>4</sup> “Off-Site Collaborators” are scientific or technical participants on the experiment; who will not be present, sending sample, or operating the magnet system remotely; and who are not located on the campus of that facility (i.e., they are off-site).

Note: Users using multiple facilities are counted in each facility listed.

**Table 2: User Affiliation**

High B/T Facility	Users	NHMFL-Affiliated Users <sup>1</sup>	Local Users <sup>1</sup>	University Users <sup>2,4</sup>	Industry Users <sup>4</sup>	National Lab Users <sup>3,4</sup>
Senior Personnel, U.S.	7	2	0	7	0	0
Senior Personnel, non-U.S.	4	0	0	3	0	1
Postdocs, U.S.	3	1	1	3	0	0
Postdocs, non-U.S.	2	0	0	2	0	0
Students, U.S.	3	0	0	3	0	0
Students, non-U.S.	1	0	0	1	0	0
Technician, U.S.	0	0	0	0	0	0
Technician, non-U.S.	0	0	0	0	0	0
<b>Total:</b>	<b>20</b>	<b>3</b>	<b>1</b>	<b>19</b>	<b>0</b>	<b>1</b>

<sup>1</sup> NHMFL-Affiliated users are defined as anyone in the lab’s personnel system [i.e. on our Web site/directory], even if they travel to another site. Local users are defined as any non-NHMFL-Affiliated researchers originating at any of the institutions in proximity to the MagLab sites (i.e. researchers at FSU, UF, FAMU, or LANL), even if they travel to another site.

<sup>2</sup> The sum of NHMFL-Affiliated and Local users equals what was formerly referred to as “Internal Investigators”.

<sup>3</sup> In addition to external users, all users with primary affiliations at FSU, UF, or FAMU are reported in this category, even if they are also NHMFL associates.

<sup>4</sup> In addition to external users, users with primary affiliations at NHMFL/LANL are reported in this category.

Note: The total of university, industry, and national lab users will equal the total number of users.

Users using multiple facilities are counted in each facility listed.

# Appendix I – User Facility Statistics

HBT

HBT

**Table 3: User by Discipline**

High B/T Facility	Users	Condensed Matter Physics	Chemistry, Geochemistry	Engineering	Magnets, Materials, Testing, Instrum.	Biology, Biochem, Biophys.
Senior Personnel, U.S.	7	4	0	2	0	1
Senior Personnel, non-U.S.	4	4	0	0	0	0
Postdocs, U.S.	3	3	0	0	0	0
Postdocs, non-U.S.	2	2	0	0	0	0
Students, U.S.	3	3	0	0	0	0
Students, non-U.S.	1	1	0	0	0	0
Technician, U.S.	0	0	0	0	0	0
Technician, non-U.S.	0	0	0	0	0	0
<b>Total:</b>	<b>20</b>	<b>17</b>	<b>0</b>	<b>2</b>	<b>0</b>	<b>1</b>

Note: Users using multiple facilities are counted in each facility listed.

**Table 4: User Facility Operations**

High B/T Facility	16T Bay 3	8T Bay 2	10T Williamson Hall	4T Williamson Hall	Total Days Used	Percentage of Total Days Used
<b>Number of Magnet Days<sup>1</sup></b>						
NHMFL-Affiliated	0	0	0	0	0	0%
Local	0	0	0	0	0	0%
U.S. University	21	69	124	0	214	36.27%
U.S. Govt. Lab.	0	0	0	0	0	0%
U.S. Industry	0	0	0	0	0	0%
Non-U.S.	189	0	0	0	189	32.04%
Test, Calibration, Set-up, Maintenance, Inst. Dev.	0	16	0	171	187	31.69%
<b>Total:</b>	<b>210</b>	<b>85</b>	<b>124</b>	<b>171</b>	<b>590</b>	<b>100%</b>

<sup>1</sup> User Units are defined as magnet days. One magnet day is defined as 24 hours in superconducting magnets.

**Table 5: Operations by Discipline**

High B/T Facility	Total Days Used	Condensed Matter Physics	Chemistry, Geochemistry	Engineering	Magnets, Materials, Testing, Instrum.	Biology, Biochem, Biophys.
<b>Number of Magnet Days<sup>1</sup></b>						
NHMFL-Affiliated	0	0	0	0	0	0
Local	0	0	0	0	0	0
U.S. University	214	214	0	0	0	0
U.S. Govt. Lab.	0	0	0	0	0	0
U.S. Industry	0	0	0	0	0	0
Non-U.S.	189	189	0	0	0	0
Test, Calibration, Set-up, Maintenance, Inst. Dev.	187	187	0	0	0	0
<b>Total:</b>	<b>590</b>	<b>590</b>	<b>0</b>	<b>0</b>	<b>0</b>	<b>0</b>

<sup>1</sup> User Units are defined as magnet days. One magnet day is defined as 24 hours in superconducting magnets.

# Appendix I – User Facility Statistics

HBT

HBT

**Table 6: User Program Experiment Pressure**

1. Experiments Submitted (Current Year)	2. Experiments Submitted (Deferred from Prev. Year)	3. Experiments with Usage	4. Experiments Submitted (Declined/Deferred to Next Year)	5. Experiments Reviewed	6. Subscription Rate
10	5	9 (60%)	6 (40%)	15	166.67%

**Table 7: New User PI's**

Name	Organization	Proposal	Is New To MagLab
Crawford, Thomas	University of South Carolina	P16078	Yes
Smet, Jurgen	Max Planck Institute for Solid State Research, Stuttgart, Germany	P16236	Yes
<b>Total: 2</b>			

Note: PIs who received magnet time for the first time.

**Table 8: Research Proposal Profile with Magnet Time**

High B/T Facility	Total	Minority <sup>2</sup>	Female <sup>3</sup>	Condensed Matter Physics	Chemistry, Geochemistry	Engineering	Magnets, Materials, Testing, Instrum.	Biology, Biochem, Biophys.
Number of Proposals	7	0	0	6	0	0	0	1

- <sup>1.</sup> A "proposal" may have associated with it a single experiment or a group of closely related experiments. A PI may have more than one proposal.
- <sup>2.</sup> The number of proposals satisfying one of the following two conditions: (a) the PI is a minority OR (b) the PI is a non-minority working at a minority-serving college or university AND the proposal includes minority participants.
- <sup>3.</sup> The number of proposals satisfying one of the following two conditions: (a) the PI is a female OR (b) the PI is a male working at a college or university for women AND the proposal includes female participants.

**Find the list of High B/T user proposals in Appendix VI**

# Appendix I – User Facility Statistics

ICR

ICR

## 5. ICR Facility

**Table 1: User Demographics**

ICR Facility	Users	Male	Female	Other	Prefer Not to Respond to Gender	Minority <sup>1</sup>	Non-Minority <sup>1</sup>	Prefer Not to Respond to Race	Users Present	Users Operating Remotely <sup>2</sup>	Users Sending Sample <sup>3</sup>	Off-Site Collaborators <sup>4</sup>
Senior Personnel, U.S.	126	70	27	0	29	6	112	8	31	0	6	89
Senior Personnel, non-U.S.	60	26	9	0	25	7	50	3	4	0	1	55
Postdocs, U.S.	18	7	10	0	1	2	16	0	10	0	1	7
Postdocs, non-U.S.	5	3	1	0	1	1	4	0	0	0	1	4
Students, U.S.	57	22	23	0	12	6	47	4	34	0	3	20
Students, non-U.S.	11	7	3	0	1	3	6	2	3	0	2	6
Technician, U.S.	8	6	2	0	0	0	7	1	5	0	0	3
Technician, non-U.S.	0	0	0	0	0	0	0	0	0	0	0	0
<b>Total:</b>	<b>285</b>	<b>141</b>	<b>75</b>	<b>0</b>	<b>69</b>	<b>25</b>	<b>242</b>	<b>18</b>	<b>87</b>	<b>0</b>	<b>14</b>	<b>184</b>

<sup>1</sup> NSF Minority status includes the following races: American Indian, Alaska Native, Black or African American, Hispanic, Native Hawaiian or other Pacific Islander. The definition also includes Hispanic Ethnicity as a minority group. Minority status excludes Asian and White-Not of Hispanic Origin

<sup>2</sup> “Users Operating Remotely” refers to users who operate the magnet system from a remote location. Remote operations are not currently available in all facilities.

<sup>3</sup> “Users Sending Sample” refers to users who send the sample to the facility and/or research group and the experiment is conducted by other collaborators on the experiment. Users at UF, FSU, and LANL cannot be “sample senders” for facilities located on their campuses.

<sup>4</sup> “Off-Site Collaborators” are scientific or technical participants on the experiment; who will not be present, sending sample, or operating the magnet system remotely; and who are not located on the campus of that facility (i.e., they are off-site).

Note: Users using multiple facilities are counted in each facility listed.

**Table 2: User Affiliation**

ICR Facility	Users	NHMFL-Affiliated Users <sup>1</sup>	Local Users <sup>1</sup>	University Users <sup>2,4</sup>	Industry Users <sup>4</sup>	National Lab Users <sup>3,4</sup>
Senior Personnel, U.S.	126	13	13	102	11	13
Senior Personnel, non-U.S.	60	0	0	38	18	4
Postdocs, U.S.	18	3	6	18	0	0
Postdocs, non-U.S.	5	0	0	3	0	2
Students, U.S.	57	9	16	56	0	1
Students, non-U.S.	11	0	0	11	0	0
Technician, U.S.	8	2	2	6	2	0
Technician, non-U.S.	0	0	0	0	0	0
<b>Total:</b>	<b>285</b>	<b>27</b>	<b>37</b>	<b>234</b>	<b>31</b>	<b>20</b>

<sup>1</sup> NHMFL-Affiliated users are defined as anyone in the lab’s personnel system [i.e. on our Web site/directory], even if they travel to another site. Local users are defined as any non-NHMFL-Affiliated researchers originating at any of the institutions in proximity to the MagLab sites (i.e. researchers at FSU, UF, FAMU, or LANL), even if they travel to another site.

<sup>2</sup> The sum of NHMFL-Affiliated and Local users equals what was formerly referred to as “Internal Investigators”.

<sup>3</sup> In addition to external users, all users with primary affiliations at FSU, UF, or FAMU are reported in this category, even if they are also NHMFL associates.

<sup>4</sup> In addition to external users, users with primary affiliations at NHMFL/LANL are reported in this category.

Note: The total of university, industry, and national lab users will equal the total number of users.

Users using multiple facilities are counted in each facility listed.

# Appendix I – User Facility Statistics

ICR

ICR

**Table 3: User by Discipline**

ICR Facility	Users	Condensed Matter Physics	Chemistry, Geochemistry	Engineering	Magnets, Materials, Testing, Instrum.	Biology, Biochem., Biophys.
Senior Personnel, U.S.	126	0	67	10	4	45
Senior Personnel, non-U.S.	60	2	44	4	2	8
Postdocs, U.S.	18	0	8	4	0	6
Postdocs, non-U.S.	5	0	3	0	1	1
Students, U.S.	57	0	37	6	0	14
Students, non-U.S.	11	0	8	1	0	2
Technician, U.S.	8	0	4	1	1	2
Technician, non-U.S.	0	0	0	0	0	0
<b>Total:</b>	<b>285</b>	<b>2</b>	<b>171</b>	<b>26</b>	<b>8</b>	<b>78</b>

Note: Users using multiple facilities are counted in each facility listed.

**Table 4: User Facility Operations**

ICR Facility	21 T Hybrid	14.5 T Hybrid	9.4. T Passive	9.4. T Active	Total Days Used	Percentage of Total Days Used
<b>Number of Magnet Days<sup>1</sup></b>						
NHMFL-Affiliated	58.83	68.5	76.42	0	<b>203.75</b>	18.19%
Local	33.42	0	9	0	<b>42.42</b>	3.79%
U.S. University	95.92	0.5	64	43	<b>203.42</b>	18.15%
U.S. Govt. Lab.	9.33	0	1.5	0	<b>10.83</b>	0.97%
U.S. Industry	3	0	6.08	0	<b>9.08</b>	0.81%
Non-U.S.	4.5	0	47.5	87.5	<b>139.5</b>	12.46%
Test, Calibration, Set-up, Maintenance, Inst. Dev.	67	259	27.5	157.5	<b>511</b>	45.63%
<b>Total:</b>	<b>272</b>	<b>328</b>	<b>232</b>	<b>288</b>	<b>1,120</b>	<b>100%</b>

<sup>1</sup> User Units are defined as magnet days. One magnet day is defined as 24 hours in superconducting magnets.

**Table 5: Operations by Discipline**

ICR Facility	Total Days Used	Condensed Matter Physics	Chemistry, Geochemistry	Engineering	Magnets, Materials, Testing, Instrum.	Biology, Biochem, Biophys.
<b>Number of Magnet Days<sup>1</sup></b>						
NHMFL-Affiliated	<b>203.75</b>	0	80.42	4.5	101.42	17.42
Local	<b>42.42</b>	0	16.83	0	0	25.58
U.S. University	<b>203.42</b>	0	148.42	3.17	0	51.82
U.S. Govt. Lab.	<b>10.83</b>	0	3.25	0	0	7.58
U.S. Industry	<b>9.08</b>	0	8.08	0	0	1
Non-U.S.	<b>139.5</b>	0	139.5	0	0	0
Test, Calibration, Set-up, Maintenance, Inst. Dev.	<b>511</b>	0	4	0	496.18	10.83
<b>Total:</b>	<b>1,120</b>	<b>0</b>	<b>400.5</b>	<b>7.67</b>	<b>597.59</b>	<b>114.24</b>

<sup>1</sup> User Units are defined as magnet days. One magnet day is defined as 24 hours in superconducting magnets.



# Appendix I – User Facility Statistics

ICR

ICR

**Table 6: User Program Experiment Pressure**

1. Experiments Submitted (Current Year)	2. Experiments Submitted (Deferred from Prev. Year)	3. Experiments with Usage	4. Experiments Submitted (Declined/Deferred to Next Year)	5. Experiments Reviewed	6. Subscription Rate
105	50	136 (87.74%)	19 (12.26%)	155	113.97%

**Table 7: New User PI's**

Name	Organization	Proposal	Is New To MagLab
Abbott, Benjamin	Michigan State University	P16158	Yes
Agarwal, Archana	University of Utah	P17485	Yes
Aiken, George	U.S. Geological Survey	P14816	Yes
Baker, Andy	University of New South Wales	P16162	Yes
Boeckx, Pascal	Ghent University	P16318	Yes
Campbell, Eleanor	University of Edinburgh	P16141	Yes
Combariza, Marianny	Industrial University of Santander	P16111	Yes
Gomez-Escudero, Andrea	Universidad del Quindio	P17451	Yes
Goodlett, David	University of Maryland, Baltimore	P16153	Yes
Guillemette, Francois	University of Quebec at Trois-Rivières	P16207	Yes
Harshman, Sean	Air Force Research Laboratory	P16238	Yes
Hartman, Ryan	New York University	P17567	Yes
Hunt, Donald	University of Virginia	P16320	Yes
Novak, Paige	University of Minnesota, Twin Cities	P17380	Yes
Pisani, Oliva	Florida International University	P12584	Yes
Poulin, Brett	U.S. Geological Survey	P16230	Yes
Ren, Zhiyong	University of Colorado, Boulder	P17328	Yes
Wittrig, Ashley	Exxon Mobil	P16231	Yes
Yu, Yun	University of Colorado, Boulder	P17453	Yes
<b>Total: 19</b>			

Note: PIs who received magnet time for the first time.

**Table 8: Research Proposal<sup>1</sup> Profile with Magnet Time**

ICR Facility	Total	Minority <sup>2</sup>	Female <sup>3</sup>	Condensed Matter Physics	Chemistry, Geochemistry	Engineering	Magnets, Materials, Testing, Instrum.	Biology, Biochem., Biophys.
Number of Proposals <sup>1</sup>	96	10	21	0	67	3	5	21

- <sup>1.</sup> A "proposal" may have associated with it a single experiment or a group of closely related experiments. A PI may have more than one proposal.
- <sup>2.</sup> The number of proposals satisfying one of the following two conditions: (a) the PI is a minority OR (b) the PI is a non-minority working at a minority-serving college or university AND the proposal includes minority participants.
- <sup>3.</sup> The number of proposals satisfying one of the following two conditions: (a) the PI is a female OR (b) the PI is a male working at a college or university for women AND the proposal includes female participants.

**Find the list of ICR user proposals in Appendix VI**

# Appendix I – User Facility Statistics

NMR

NMR

## 6. NMR/MRI Facility, Tallahassee

**Table 1: User Demographics**

NMR Facility	Users	Male	Female	Other	Prefer Not to Respond to Gender	Minority <sup>1</sup>	Non-Minority <sup>1</sup>	Prefer Not to Respond to Race	Users Present	Users Operating Remotely <sup>2</sup>	Users Sending Sample <sup>3</sup>	Off-Site Collaborators <sup>4</sup>
Senior Personnel, U.S.	120	82	17	0	21	7	110	3	33	12	2	73
Senior Personnel, non-U.S.	48	22	4	0	22	2	43	3	2	6	1	39
Postdocs, U.S.	32	17	11	0	4	7	25	0	16	2	6	8
Postdocs, non-U.S.	6	3	0	0	3	0	6	0	0	2	0	4
Students, U.S.	55	34	14	0	7	6	49	0	26	5	12	12
Students, non-U.S.	9	3	4	0	2	2	6	1	4	0	0	5
Technician, U.S.	8	5	3	0	0	2	6	0	6	2	0	0
Technician, non-U.S.	2	2	0	0	0	0	2	0	1	0	0	1
<b>Total:</b>	<b>280</b>	<b>168</b>	<b>53</b>	<b>0</b>	<b>59</b>	<b>26</b>	<b>247</b>	<b>7</b>	<b>88</b>	<b>29</b>	<b>21</b>	<b>142</b>

<sup>1</sup> NSF Minority status includes the following races: American Indian, Alaska Native, Black or African American, Hispanic, Native Hawaiian or other Pacific Islander. The definition also includes Hispanic Ethnicity as a minority group. Minority status excludes Asian and White-Not of Hispanic Origin

<sup>2</sup> "Users Operating Remotely" refers to users who operate the magnet system from a remote location. Remote operations are not currently available in all facilities.

<sup>3</sup> "Users Sending Sample" refers to users who send the sample to the facility and/or research group and the experiment is conducted by other collaborators on the experiment. Users at UF, FSU, and LANL cannot be "sample senders" for facilities located on their campuses.

<sup>4</sup> "Off-Site Collaborators" are scientific or technical participants on the experiment; who will not be present, sending sample, or operating the magnet system remotely; and who are not located on the campus of that facility (i.e., they are off-site).

Note: Users using multiple facilities are counted in each facility listed.

**Table 2: User Affiliation**

NMR Facility	Users	NHMFL-Affiliated Users <sup>1</sup>	Local Users <sup>1</sup>	University Users <sup>2,4</sup>	Industry Users <sup>4</sup>	National Lab Users <sup>3,4</sup>
Senior Personnel, U.S.	120	34	13	113	5	2
Senior Personnel, non-U.S.	48	1	0	27	11	10
Postdocs, U.S.	32	8	6	28	4	0
Postdocs, non-U.S.	6	0	0	2	0	4
Students, U.S.	55	11	12	54	1	0
Students, non-U.S.	9	1	0	9	0	0
Technician, U.S.	8	5	1	7	1	0
Technician, non-U.S.	2	0	0	0	1	1
<b>Total:</b>	<b>280</b>	<b>60</b>	<b>32</b>	<b>240</b>	<b>23</b>	<b>17</b>

<sup>1</sup> NHMFL-Affiliated users are defined as anyone in the lab's personnel system [i.e. on our Web site/directory], even if they travel to another site. Local users are defined as any non-NHMFL-Affiliated researchers originating at any of the institutions in proximity to the MagLab sites (i.e. researchers at FSU, UF, FAMU, or LANL), even if they travel to another site.

<sup>2</sup> The sum of NHMFL-Affiliated and Local users equals what was formerly referred to as "Internal Investigators".

<sup>3</sup> In addition to external users, all users with primary affiliations at FSU, UF, or FAMU are reported in this category, even if they are also NHMFL associates.

<sup>4</sup> In addition to external users, users with primary affiliations at NHMFL/LANL are reported in this category.

Note: The total of university, industry, and national lab users will equal the total number of users.

Users using multiple facilities are counted in each facility listed.

# Appendix I – User Facility Statistics

NMR

NMR

**Table 3: User by Discipline**

NMR Facility	Users	Condensed Matter Physics	Chemistry, Geochemistry	Engineering	Magnets, Materials, Testing, Instrum.	Biology, Biochem, Biophys.
Senior Personnel, U.S.	120	5	32	22	9	52
Senior Personnel, non-U.S.	48	1	13	4	9	21
Postdocs, U.S.	32	0	9	2	2	19
Postdocs, non-U.S.	6	1	0	0	0	5
Students, U.S.	55	1	17	16	4	17
Students, non-U.S.	9	1	4	0	0	4
Technician, U.S.	8	0	1	2	2	3
Technician, non-U.S.	2	0	2	0	0	0
<b>Total:</b>	<b>280</b>	<b>9</b>	<b>78</b>	<b>46</b>	<b>26</b>	<b>121</b>

Note: Users using multiple facilities are counted in each facility listed.

**Table 4: User Facility Operations**

NMR Facility	900	830	800NB	800MB	600	600WB	600WB2	600DNP	500	500E	Total Days Used	Percentage of Total Days Used
Number of Magnet Days <sup>1</sup>												
NHMFL-Affiliated	103	9	75	121.5	0	264	273	3	42	42	1,050.5	30.74%
Local	2	0	47	0	9	0	6	0	7	114.5	185.5	5.43%
U.S. University	182	277	216	149	0	86	67	99	262	118.5	1,456.5	42.63%
U.S. Govt. Lab.	0	0	0	0	0	0	0	0	0	0	0	0%
U.S. Industry	0	5	0	0	0	0	0	9.5	0	4	18.5	0.54%
Non-U.S.	69	10	22	52	149.5	0	19	29	45	0	395.5	11.57%
Test, Calibration, Set-up, Maintenance, Inst. Dev.	9	53	2	42.5	18.5	12	0	138.5	0	30	310.5	9.09%
<b>Total:</b>	<b>365</b>	<b>354</b>	<b>362</b>	<b>365</b>	<b>177</b>	<b>362</b>	<b>365</b>	<b>279</b>	<b>356</b>	<b>309</b>	<b>3,417</b>	<b>100%</b>

<sup>1</sup> User Units are defined as magnet days. One magnet day is defined as 24 hours in superconducting magnets.

**Table 5: Operations by Discipline**

NMR Facility	Total Days Used	Condensed Matter Physics	Chemistry, Geochemistry	Engineering	Magnets, Materials, Testing, Instrum.	Biology, Biochem, Biophys.
Number of Magnet Days <sup>1</sup>						
NHMFL-Affiliated	1,050.5	0	54	0	17	979.5
Local	185.5	0	13	32	0	140.5
U.S. University	1,456.5	0	647	21	3	785.5
U.S. Govt. Lab.	0	0	0	0	0	0
U.S. Industry	18.5	0	14.5	0	0	4
Non-U.S.	395.5	0	251	0	0	144.5
Test, Calibration, Set-up, Maintenance, Inst. Dev.	310.5	0	0	0	141	169.5
<b>Total:</b>	<b>3,417</b>	<b>0</b>	<b>979.5</b>	<b>53</b>	<b>161</b>	<b>2,223.5</b>

<sup>1</sup> User Units are defined as magnet days. One magnet day is defined as 24 hours in superconducting magnets.

# Appendix I – User Facility Statistics

NMR

NMR

**Table 6: User Program Experiment Pressure**

1. Experiments Submitted (Current Year)	2. Experiments Submitted (Deferred from Prev. Year)	3. Experiments with Usage	4. Experiments Submitted (Declined/Deferred to Next Year)	5. Experiments Reviewed	6. Subscription Rate
503	45	470 (85.77%)	78 (14.23%)	548	116.60%

**Table 7: New User PI's**

Name	Organization	Proposal	Is New To MagLab
Ajayan, Pulickel	Rice University	P16305	Yes
Badisa, Ramesh	Florida Agricultural and Mechanical University	P16090	Yes
Blue, Ashley	National High Magnetic Field Laboratory (NHMFL)	P16319	Yes
Bunnell, Bruce	Tulane University	P16124	Yes
Chen, Zhong	Xiamen University	P16159	Yes
Cheng, Chi-yuan	Colgate-Palmolive Company	P16063	Yes
Dybowski, Cecil	University of Delaware	P17354	Yes
Fichter, Katye	Missouri State University	P16080	Yes
Hadimani, Ravi	Virginia Commonwealth University	P17390	Yes
Haile, Sossina	Northwestern University	P16051	Yes
Ippolito, Joseph	Washington University School of Medicine in St. Louis	P17381	Yes
Kennemur, Justin	Florida State University (FSU)	P17413	Yes
Leftin, Avigdor	Weizmann Institute of Science	P16232	Yes
Marinas, Benito	University of Illinois at Urbana-Champaign	P17334	Yes
Mohammadigoushki, Hadi	Florida State University (FSU)	P17560	Yes
Pinto, Jose	Florida State University (FSU)	P16052	Yes
Pomerantz, William	University of Minnesota, Twin Cities	P17419	Yes
Schad, Lothar	Heidelberg University	P14955	Yes
Tang, Christina	Virginia Commonwealth University	P16239	Yes
Waiczies, Sonia	Max Delbrück Center for Molecular Medicine in the Helmholtz Association	P17420	Yes
Wang, Tuo	Louisiana State University	P17348	Yes
Wang, Wei	Lanzhou University	P16043	Yes
Xu, Jun	Wuhan Institute of Physics & Mathematics, Chinese Academy of Sciences	P16062	Yes
Yang, Yong	Xiamen University	P17445	Yes
<b>Total: 24</b>			

Note: PIs who received magnet time for the first time.

**Table 8: Research Proposal<sup>1</sup> Profile with Magnet Time**

NMR Facility	Total	Minority <sup>2</sup>	Female <sup>3</sup>	Condensed Matter Physics	Chemistry, Geochemistry	Engineering	Magnets, Materials, Testing, Instrum.	Biology, Biochem, Biophys.
Number of Proposals <sup>1</sup>	93	8	14	1	22	5	6	59

<sup>1</sup> A "proposal" may have associated with it a single experiment or a group of closely related experiments. A PI may have more than one proposal.

<sup>2</sup> The number of proposals satisfying one of the following two conditions: (a) the PI is a minority OR (b) the PI is a non-minority working at a minority-serving college or university AND the proposal includes minority participants.

<sup>3</sup> The number of proposals satisfying one of the following two conditions: (a) the PI is a female OR (b) the PI is a male working at a college or university for women AND the proposal includes female participants.

**Find the list of NMR user proposals in Appendix VI**

# Appendix I – User Facility Statistics

PFF

PFF

## 7. Pulsed Field Facility

**Table 1: User Demographics**

Pulsed Field Facility	Users	Male	Female	Other	Prefer Not to Respond to Gender	Minority <sup>1</sup>	Non-Minority <sup>1</sup>	Prefer Not to Respond to Race	Users Present	Users Operating Remotely <sup>2</sup>	Users Sending Sample <sup>3</sup>	Off-Site Collaborators <sup>4</sup>
Senior Personnel, U.S.	52	44	7	0	1	2	47	3	25	0	0	27
Senior Personnel, non-U.S.	20	14	4	0	2	1	17	2	2	0	1	17
Postdocs, U.S.	22	16	3	0	3	2	20	0	18	0	1	3
Postdocs, non-U.S.	6	3	2	0	1	0	5	1	6	0	0	0
Students, U.S.	25	16	5	0	4	0	22	3	20	0	0	5
Students, non-U.S.	11	6	3	0	2	1	10	0	5	0	3	3
Technician, U.S.	1	0	1	0	0	0	1	0	0	0	0	1
Technician, non-U.S.	0	0	0	0	0	0	0	0	0	0	0	0
<b>Total:</b>	<b>137</b>	<b>99</b>	<b>25</b>	<b>0</b>	<b>13</b>	<b>6</b>	<b>122</b>	<b>9</b>	<b>76</b>	<b>0</b>	<b>5</b>	<b>56</b>

<sup>1</sup> NSF Minority status includes the following races: American Indian, Alaska Native, Black or African American, Hispanic, Native Hawaiian or other Pacific Islander. The definition also includes Hispanic Ethnicity as a minority group. Minority status excludes Asian and White-Not of Hispanic Origin

<sup>2</sup> "Users Operating Remotely" refers to users who operate the magnet system from a remote location. Remote operations are not currently available in all facilities.

<sup>3</sup> "Users Sending Sample" refers to users who send the sample to the facility and/or research group and the experiment is conducted by other collaborators on the experiment. Users at UF, FSU, and LANL cannot be "sample senders" for facilities located on their campuses.

<sup>4</sup> "Off-Site Collaborators" are scientific or technical participants on the experiment; who will not be present, sending sample, or operating the magnet system remotely; and who are not located on the campus of that facility (i.e., they are off-site).

Note: Users using multiple facilities are counted in each facility listed.

**Table 2: User Affiliation**

Pulsed Field Facility	Users	NHMFL-Affiliated Users <sup>1</sup>	Local Users <sup>1</sup>	University Users <sup>2,4</sup>	Industry Users <sup>4</sup>	National Lab Users <sup>3,4</sup>
Senior Personnel, U.S.	52	18	10	26	0	26
Senior Personnel, non-U.S.	20	0	0	17	0	3
Postdocs, U.S.	22	4	8	9	0	13
Postdocs, non-U.S.	6	0	0	4	0	2
Students, U.S.	25	0	3	21	0	4
Students, non-U.S.	11	0	0	9	0	2
Technician, U.S.	1	0	0	0	0	1
Technician, non-U.S.	0	0	0	0	0	0
<b>Total:</b>	<b>137</b>	<b>22</b>	<b>21</b>	<b>86</b>	<b>0</b>	<b>51</b>

<sup>1</sup> NHMFL-Affiliated users are defined as anyone in the lab's personnel system [i.e. on our Web site/directory], even if they travel to another site. Local users are defined as any non-NHMFL-Affiliated researchers originating at any of the institutions in proximity to the MagLab sites (i.e. researchers at FSU, UF, FAMU, or LANL), even if they travel to another site.

<sup>2</sup> The sum of NHMFL-Affiliated and Local users equals what was formerly referred to as "Internal Investigators".

<sup>3</sup> In addition to external users, all users with primary affiliations at FSU, UF, or FAMU are reported in this category, even if they are also NHMFL associates.

<sup>4</sup> In addition to external users, users with primary affiliations at NHMFL/LANL are reported in this category.

Note: The total of university, industry, and national lab users will equal the total number of users.

Users using multiple facilities are counted in each facility listed.

# Appendix I – User Facility Statistics

PFF

PFF

**Table 3: User by Discipline**

Pulsed Field Facility	Users	Condensed Matter Physics	Chemistry, Geochemistry	Engineering	Magnets, Materials, Testing, Instrum.	Biology, Biochem, Biophys.
Senior Personnel, U.S.	52	43	3	2	1	3
Senior Personnel, non-U.S.	20	18	2	0	0	0
Postdocs, U.S.	22	22	0	0	0	0
Postdocs, non-U.S.	6	5	1	0	0	0
Students, U.S.	25	22	3	0	0	0
Students, non-U.S.	11	9	2	0	0	0
Technician, U.S.	1	1	0	0	0	0
Technician, non-U.S.	0	0	0	0	0	0
<b>Total:</b>	<b>137</b>	<b>120</b>	<b>11</b>	<b>2</b>	<b>1</b>	<b>3</b>

Note: Users using multiple facilities are counted in each facility listed.

**Table 4: User Facility Operations**

Pulsed Field Facility	Short Pulse	100T	Single Turn	Total Days Used	Percentage of Total Days Used
Number of Magnet Days <sup>1</sup>					
NHMFL-Affiliated	113	25	0	138	22.55%
Local	26	0	4	30	4.90%
U.S. University	206	10	0	216	35.29%
U.S. Govt. Lab.	64	0	0	64	10.46%
U.S. Industry	0	0	0	0	0%
Non-U.S.	155	5	0	160	26.15%
Test, Calibration, Set-up, Maintenance, Inst. Dev.	4	0	0	4	0.65%
<b>Total:</b>	<b>568</b>	<b>40</b>	<b>4</b>	<b>612</b>	<b>100%</b>

<sup>1</sup> User Units are defined as magnet days. Magnets are scheduled typically 12 hours a day.

**Table 5: Operations by Discipline**

Pulsed Field Facility	Total Days Used	Condensed Matter Physics	Chemistry, Geochemistry	Engineering	Magnets, Materials, Testing, Instrum.	Biology, Biochem, Biophys.
Number of Magnet Days <sup>1</sup>						
NHMFL-Affiliated	138	110	0	0	28	0
Local	30	26	0	0	4	0
U.S. University	216	211	5	0	0	0
U.S. Govt. Lab.	64	64	0	0	0	0
U.S. Industry	0	0	0	0	0	0
Non-U.S.	160	160	0	0	0	0
Test, Calibration, Set-up, Maintenance, Inst. Dev.	4	4	0	0	0	0
<b>Total:</b>	<b>612</b>	<b>575</b>	<b>5</b>	<b>0</b>	<b>32</b>	<b>0</b>

<sup>1</sup> User Units are defined as magnet days. Magnets are scheduled typically 12 hours a day.

# Appendix I – User Facility Statistics

PFF

PFF

**Table 6: User Program Experiment Pressure**

1. Experiments Submitted (Current Year)	2. Experiments Submitted (Deferred from Prev. Year)	3. Experiments with Usage	4. Experiments Submitted (Declined/Deferred to Next Year)	5. Experiments Reviewed	6. Subscription Rate
75	27	72 (70.59%)	30 (29.41%)	102	141.67%

**Table 7: New User PI's**

Organization	Proposal	Is New To MagLab	
Buehler-Paschen, Silke	Technical University of Wien	P15985	No
Checkelsky, Joseph	Massachusetts Institute of Technology	P08337	No
Crooker, Scott	National High Magnetic Field Laboratory (NHMFL)	P00734	No
Ding, Xiaxin	National High Magnetic Field Laboratory (NHMFL)	P17375	Yes
Esquinazi, Pablo	Leipzig University	P14986	No
Haravifard, Sara	Duke University	P02465	No
Hu, Jin	Tulane University	P14984	No
Kim, Jeehoon	Pohang University of Science and Technology	P14985	Yes
Miura, Masashi	Seikei University	P16306	Yes
Morgan, Grace	University College Dublin	P16285	Yes
Reagor, David	Los Alamos National Laboratory	P17327	Yes
Schaller, Richard	Argonne National Laboratory	P16100	Yes
Señaris-Rodriguez, Maria	University of Coruna	P14979	Yes
Vecchione, Antonio	CNR Institute SPIN	P16262	Yes
Wang, Haiyan	Texas A&M University	P07300	Yes
<b>Total: 15</b>			

Note: PIs who received magnet time for the first time.

**Table 8: Research Proposal<sup>1</sup> Profile with Magnet Time**

Pulsed Field Facility	Total	Minority <sup>2</sup>	Female <sup>3</sup>	Condensed Matter Physics	Chemistry, Geochemistry	Engineering	Magnets, Materials, Testing, Instrum.	Biology, Biochem, Biophys.
Number of Proposals <sup>1</sup>	50	1	8	44	1	1	3	1

<sup>1.</sup> A "proposal" may have associated with it a single experiment or a group of closely related experiments. A PI may have more than one proposal.

<sup>2.</sup> The number of proposals satisfying one of the following two conditions: (a) the PI is a minority OR (b) the PI is a non-minority working at a minority-serving college or university AND the proposal includes minority participants.

<sup>3.</sup> The number of proposals satisfying one of the following two conditions: (a) the PI is a female OR (b) the PI is a male working at a college or university for women AND the proposal includes female participants.

**Find the list of PFF user proposals in Appendix VI**



# Appendix II – User Facilities Overview

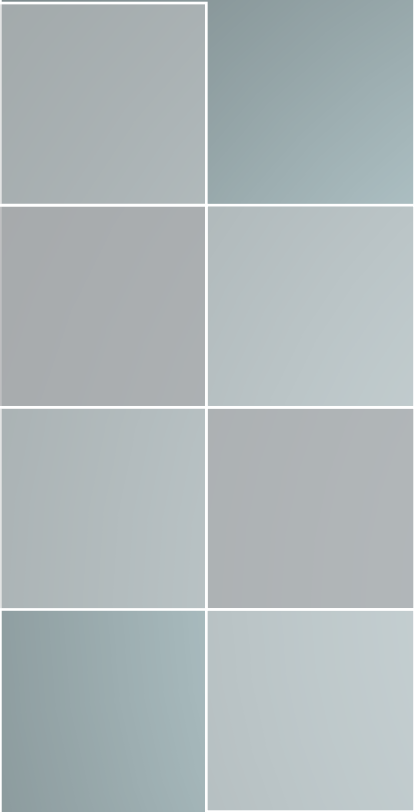



# Appendix II – User Facilities Overview

## Overall Statistics across All NHMFL User Facilities

### User Demographics of All Facilities

**Table 1: MagLab User Profile (Demographics) for 2017**

	Users	Male	Female	Other	No Response to Gender	Minority <sup>1</sup>	Non-Minority <sup>1</sup>	No Response to Race	Affil. Users <sup>2</sup>	Local Users <sup>2</sup>	Uni. Users <sup>3,5</sup>	Indus. Users <sup>5</sup>	National Lab Users <sup>4,5</sup>
Senior Personnel, U.S.	675	442	101	0	132	32	598	45	167	79	587	19	69
Senior Personnel, non-U.S.	245	147	33	0	65	19	210	16	2	0	170	31	44
Postdocs, U.S.	196	122	50	0	24	22	167	7	33	37	168	6	22
Postdocs, non-U.S.	47	30	7	0	10	1	41	5	0	0	32	0	15
Students, U.S.	483	275	114	0	94	29	429	25	38	97	473	1	9
Students, non-U.S.	94	64	19	0	11	8	77	9	1	0	88	0	6
Technician, U.S.	65	25	21	0	19	8	54	3	19	16	61	3	1
Technician, non-U.S.	4	4	0	0	0	0	4	0	0	0	2	1	1
<b>Total</b>	<b>1,809</b>	<b>1,109</b>	<b>345</b>	<b>0</b>	<b>355</b>	<b>119</b>	<b>1,580</b>	<b>110</b>	<b>260</b>	<b>229</b>	<b>1,581</b>	<b>61</b>	<b>167</b>

<sup>1</sup> NSF Minority status includes the following races: American Indian, Alaska Native, Black or African American, Hispanic, Native Hawaiian or other Pacific Islander. The definition also includes Hispanic Ethnicity as a minority group. Minority status excludes Asian and White-Not of Hispanic Origin.

<sup>2</sup> NHMFL-Affiliated users are defined as anyone in the lab's personnel system [i.e. on our Web site/directory], even if they travel to another site. Local users are defined as any non-NHMFL-Affiliated researchers originating at any of the institutions in proximity to the MagLab sites (i.e. researchers at FSU, UF, FAMU, or LANL), even if they travel to another site.

<sup>3</sup> In addition to external users, all users with primary affiliations at FSU, UF, or FAMU are reported in this category, even if they are also NHMFL associates.

<sup>4</sup> In addition to external users, users with primary affiliations at NHMFL/LANL are reported in this category.

<sup>5</sup> The total of university, industry, and national lab users will equal the total number of users.

### New PI

In 2017, 1,809 users from around the world enjoyed access to magnet time at the lab's seven user facilities at three sites. The MagLab was extremely pleased to welcome requests for magnet time from 122 new principal investigators in 2017: 9

in NMR-MRI@UF (AMRIS-NSF Funded), 17 in NMR-MRI@UF (AMRIS-Non NHMFL Funded), 26 in the DC Field Facility, 12 in EMR, 2 in the High B/T, 19 in ICR, 24 in NMR-MRI@FSU and 13 in the Pulsed Field facility. All 122 of these new PIs submitted a request and received magnet time during the year.

### User Affiliation

**Table 2: MagLab Facility Usage Profile (Type of Affiliation) for 2017**

	Total days used <sup>1</sup>	Condensed Matter Physics	Chem. Geochem	Engineering	Magnets, Materials, Test, Instr.	Biology, Biochem, Biophys
NHMFL-Affiliated	2,562.6	472.3	147	4.5	384.3	1,554.5
Local	394	47	77.3	32	4	233.6
U.S. University	4,721.4	1,298.2	1,082	212.9	39.4	2,088.8
U.S. Govt. Lab.	172.9	162.1	3.3	0	0	7.6
U.S. Industry	34.6	0	22.6	7	0	5
Non-U.S.	1,493.1	701.1	560.4	14	34.8	182.8
Test, Calibration, Set-up, Maintenance, Inst. Dev.	1,781.1	211	4	0	1,251	315
<b>Total:</b>	<b>11,159.6</b>	<b>2,891.6</b>	<b>1,896.5</b>	<b>270.4</b>	<b>1,713.6</b>	<b>4,387.4</b>

<sup>1</sup> User Units are defined as magnet days for four types of magnets. Users of water-cooled resistive or hybrid magnets in Tallahassee can typically expect to receive enough energy for 7 hours a day of magnet usage, so a magnet day is defined as 7 hours. One magnet day is 12 hours in any pulsed magnet in Los Alamos and 24 hours in superconducting magnets in Tallahassee and the High B/T system in Gainesville. Magnet days for AMRIS instruments in Gainesville: Verticals (500, 600s, & 750 MHz), 1 magnet day = 24 hours (7 days/week); Horizontals (4.7 and 11 T), 1 magnet day = 8 hours (5 days/week).

# Appendix II – User Facilities Overview

## Instrumentation Operation

**Table 3: MagLab Instrumentation Operation for 2017**

User Facility	Total days used	Days outside users used <sup>8</sup>	Days in-house (NHMFL Affiliated) users used <sup>9</sup>	Days for instrument development and maintenance (Combined) <sup>10</sup>	Days awardee institution personnel (local) used <sup>11</sup>
AMRIS <sup>1</sup>	1,124	450.3	89.8	583.9	0
AMRIS Independent <sup>1</sup>	1,396	875.8	345.8	95.3	79
DC Field <sup>2</sup>	1,780.6	1,298.6	371.2	75.8	35
EMR <sup>3</sup>	1,120	721	363.5	13.5	22
High B/T <sup>4</sup>	590	403	0	187	0
ICR <sup>5</sup>	1,120	362.8	203.7	511	42.4
NMR <sup>6</sup>	3,417	1,870.5	1,050.5	310.5	185.5
Pulsed Field <sup>7</sup>	612	440	138	4	30
<b>Total</b>	<b>11,159.6</b>	<b>6,422</b>	<b>2,562.6</b>	<b>1,781.1</b>	<b>394</b>

<sup>1</sup> User Units are defined as magnet days; time utilized is recorded to the nearest 15 minutes. Magnet-day definitions for AMRIS instruments: Verticals (500, 600s, & 750 MHz), 1 magnet day = 24 hours. Horizontals (4.7 and 11.1 T), 1 magnet day = 8 hours. This accounts for the difficulty in running animal or human studies overnight. Magnet days were calculated by adding the total number of real used for each instrument and dividing by 24 (vertical) or 8 (horizontal). Note: Due to the nature of the 4.7 T and 11 T studies, almost all studies with external users were collaborative with UF investigators.

<sup>2</sup> Note: Each 20 MW resistive magnet requires two power supplies to run, the 45 T hybrid magnet requires three power supplies and the 36 T Series Connected Hybrid requires one power supply. Thus there can be four resistive magnets + three superconducting magnets operating or the 45 T hybrid, series connected hybrid, two resistive magnets and three superconducting magnets. User Units are defined as magnet days. Users of water-cooled resistive or hybrid magnets can typically expect to receive enough energy for 7 hours a day of magnet usage so a magnet day is defined as 7 hours. Superconducting magnets are scheduled typically 24 hours a day. There is an annual four week shutdown in fall of powered DC resistive and hybrid magnets for infrastructure maintenance and a two week shutdown period for the university mandated holiday break.

<sup>3,4,5,6</sup> User Units are defined as magnet days. One magnet day is defined as 24 hours in superconducting magnets.

<sup>7</sup> User Units are defined as magnet days. Magnets are scheduled typically 12 hours a day.

<sup>1,2,3,4,5,6</sup> Shutdown due to Hurricane Irma in September 2017.

<sup>8</sup> days to outside users at facility => all U.S. University, U.S. Govt. Lab., U.S. Industry, Non-U.S. excluding NHMFL Affiliated and local and Test, Calibration, Set-up, Maintenance, Inst. Dev.

<sup>9</sup> days in-house (NHMFL Affiliated) research => NHMFL Affiliated only

<sup>10</sup> days instrument development and maintenance (Combined) => test, calibration, set-up, maintenance, inst. Dev.

<sup>11</sup> days to awardee institution personnel (local) => local only

**Table 4: User Program Proposal Pressure by User Facility for 2017**

User Facility	Experiments submitted (current year)	Experiments submitted (deferred from prev. year)	Experiments reviewed	Days submitted	Days outside users used	Days awardee institution personnel (local) used	Total days used	Subscription % (days submitted/ days used)
AMRIS-NSF Funded	31	23	54	1,124	450.3	0	1,124	100%
AMRIS Non-NHMFL Funded	82	112	194	1,396	875.8	79	1,396	100%
DC Field	411	118	529	3,121	1,298.6	35	1,780.6	175.3%
EMR	151	23	174	1,707	721	22	1,120	152.4%
High B/T	10	5	15	840	403	0	590	142.4%
ICR	105	50	155	2,371	362.8	42.4	1,120	211.7%
NMR	503	45	548	3,597	1,870.5	185.5	3,417	105.3%
Pulsed Field	75	27	102	625	440	30	612	102.1%
<b>Total</b>	<b>1,368</b>	<b>403</b>	<b>1,771</b>	<b>14,781</b>	<b>6,422</b>	<b>394</b>	<b>11,159.6</b>	<b>132.5%</b>

# Appendix II – User Facilities Overview

## Funding

**Table 5: Funding Source of User's Research- Days Allotted (Counts) for 2017**

User Facility	NSF <sup>1</sup>	NIH	DOE	DOD <sup>2</sup>	VSP	FFI	UF MBI	EPA	Inter-national	National	Industry <sup>3</sup>	Other	Total days used
AMRIS NSF-Funded	801.1	35.1	44.3	1.7	0	0	17	0	47.3	177.5	0	0	1,124
AMRIS Non-NHMFL Funded	334	575.3	18.5	4.8	0	0	4.4	0	19.5	385.2	54.3	0	1,396
DC Field	679	0	463.1	88.7	0	0	0	0	276.3	245.4	28.1	0	1,780.6
EMR	687	115.5	42	42	0	0	0	0	128.5	105	0	0	1,120
High B/T	240	0	21	0	0	0	0	0	189	140	0	0	590
ICR	930.2	31.3	0.1	11.1	0	14	0	0	70.1	57.9	5.3	0	1,120
NMR	1,139.5	1,403	0	16	3.7	0	0	0	257.5	587.2	10	0	3,417
Pulsed Field	258	0	187	18	0	0	0	0	66	83	0	0	612
<b>Total</b>	<b>5,068.9</b>	<b>2,160.2</b>	<b>776</b>	<b>182.2</b>	<b>3.7</b>	<b>14</b>	<b>21.4</b>	<b>0</b>	<b>1,054.2</b>	<b>1,781.3</b>	<b>97.7</b>	<b>0</b>	<b>11,159.6</b>

<sup>1</sup> Includes NSF, UCGP, and 'No other support'

<sup>2</sup> Includes NASA, U.S. Army, U.S. Navy, and U.S. Airforce

<sup>3</sup> Includes US Industry and Non-US Industry

**Table 6: Funding Source of User's Research- Days Allotted (Percentage) for 2017**

User Facility	NSF <sup>1</sup>	NIH	DOE	DOD <sup>2</sup>	VSP	FFI	UF MBI	EPA	Inter-national	National	Industry <sup>3</sup>
AMRIS NSF-Funded	71.3	3.1	3.9	0.1	0	0	1.5	0	4.2	15.8	0
AMRIS Non-NHMFL Funded	23.9	41.2	1.3	0.3	0	0	0.3	0	1.4	27.6	3.9
DC Field	38.1	0	26	5	0	0	0	0	15.5	13.8	1.6
EMR	61.3	10.3	3.8	3.8	0	0	0	0	11.5	9.4	0
High B/T	40.7	0	3.6	0	0	0	0	0	32	23.7	0
ICR	83.1	2.8	0	1	0	1.3	0	0	6.3	5.2	0.5
NMR	33.3	41.1	0	0.5	0.1	0	0	0	7.5	17.2	0.3
Pulsed Field	42.2	0	30.6	2.9	0	0	0	0	10.8	13.6	0
<b>Total</b>	<b>45.4</b>	<b>19.4</b>	<b>7</b>	<b>1.6</b>	<b>0</b>	<b>0.1</b>	<b>0.2</b>	<b>0</b>	<b>9.4</b>	<b>16</b>	<b>0.9</b>

<sup>1</sup> Includes NSF, UCGP, and 'No other support'

<sup>2</sup> Includes NASA, U.S. Army, U.S. Navy, and U.S. Airforce

<sup>3</sup> Includes US Industry and Non-US Industry



# Appendix III – Geographic Distribution



# Appendix III – Geographic Distribution

## 1. National Distribution

### 1.1. AMRIS Facility – MagLab Funded

#### 1.1.1. a) Senior Personnel, USA – 43

Name	Organization	Country
Aaron Mattfeld (S/PI)	Florida International University	USA (FL)
Andrew Maurer (S/PI)	University of Florida	USA (FL)
Benjamin Baisier (S)	University of Florida	USA (FL)
Clifford Bowers (S/PI)	University of Florida	USA (FL)
David Harris (S/PI)	Northwestern University	USA (IL)
Erik Lilleskov (S)	US Forest Service	USA (MI)
Evan Kane (S)	Michigan Tech	USA (MI)
Fatma Kaplan (S)	Kaplan Schiller Research, LLC	USA (FL)
Frederic Mentink (S/PI)	National High Magnetic Field Laboratory (NHMFL)	USA (FL)
Glenn Walter (S/PI)	University of Florida	USA (FL)
Hae-Kwon Jeong (S/PI)	Texas A&M University	USA (TX)
Hendrik Luesch (S/PI)	University of Florida	USA (FL)
Huadong Zeng (S)	University of Florida	USA (FL)
James Rocca (S)	University of Florida	USA (FL)
Jen Bizon (S)	University of Florida	USA (FL)
Jennifer Isaacs (S/PI)	Medical University of South Carolina	USA (SC)
Jeremy Flint (S/PI)	University of Florida	USA (FL)
Joanna Long (S/PI)	University of Florida	USA (FL)
Johan van Tol (S/PI)	National High Magnetic Field Laboratory (NHMFL)	USA (FL)
Joshua Yarrow (S)	Malcom Randall VA Medical Center	USA (FL)
JR Schmidt (S/PI)	University of Wisconsin, Madison	USA (WI)
K. Ramesh Reddy (S/PI)	University of Florida	USA (FL)
Kirk Ziegler (S)	University of Florida	USA (FL)
Malisa Sarntinoranont (S/PI)	University of Florida	USA (FL)
Marcelo Febo (S/PI)	University of Florida	USA (FL)
Mark Clark (S)	University of Florida	USA (FL)
Matthew Erickson (S/PI)	University of Florida	USA (WI)
Mavis Agbandje-McKenna (S/PI)	University of Florida	USA (FL)
Michael Bowman (S/PI)	University of Alabama, Tuscaloosa	USA (AL)
Michael King (S)	University of Florida	USA (FL)
Rebecca Butcher (S/PI)	University of Florida	USA (FL)
Richard Magin (S/PI)	University of Illinois at Chicago	USA (IL)
Rodolfo Gatto (S/PI)	University of Illinois at Chicago	USA (IL)
Russel Lonser (S)	Ohio State University	USA (OH)
Ryan Lively (S/PI)	Georgia Institute of Technology	USA (GA)
S. Patricia Stock (S)	University of Arizona	USA (AZ)
Sara Burke (S)	University of Florida	USA (FL)
Sergey Vasenkov (S/PI)	University of Florida	USA (FL)
Thomas Mareci (S/PI)	University of Florida	USA (FL)
Wenyu Huang (S/PI)	Iowa State University	USA (IA)

# Appendix III – Geographic Distribution

Name	Organization	Country
William Brey (S/PI)	National High Magnetic Field Laboratory (NHMFL)	USA (FL)
Yi Zhang (S)	University of Florida	USA (FL)
Yousong Ding (S/PI)	University of Florida	USA (FL)

## 1.1.2. a) Postdocs, USA – 10

Name	Organization	Country
Adam Smith (P)	University of Florida	USA (FL)
Asahi Tomitaka (P/PI)	Florida International University	USA (FL)
Bimala Lama (P)	University of Florida	USA (FL)
Gwladys Riviere (P)	University of Florida	USA (FL)
James Collins (P)	University of Florida	USA (FL)
Johannes McKay (P)	Keysight Technologies	USA (CA)
Lilit Vardanyan (P/PI)	University of Florida	USA (FL)
Luis Colon-perez (P)	University of Florida	USA (FL)
Rachel Jones (P)	University of Florida	USA (FL)
Xiaoling Wang (P)	National High Magnetic Field Laboratory (NHMFL)	USA (FL)

## 1.1.3. a) Students, USA – 32

Name	Organization	Country
Agnes Thorarinsdottir (G)	Northwestern University	USA (IL)
Akshita Dutta (G)	University of Florida	USA (FL)
Alexandra Roder (G)	University of Arizona	USA (AZ)
Amineh Baniani (G)	University of Florida	USA (FL)
Anna Normand (G)	University of Florida	USA (FL)
Benjamin Fowler (G)	University of Alabama	USA (AL)
Chelsea Hazlett (U)	University of Florida	USA (FL)
Chip Norwood (G)	University of Florida	USA (FL)
Daniel Downes (G/PI)	University of Florida	USA (FL)
Erkang Zhou (G)	Georgia Institute of Technology	USA (GA)
Evan Forman (G)	University of Florida	USA (FL)
Evan Wenbo Zhao (G)	University of Florida	USA (FL)
Guangde Jiang (G)	University of Florida	USA (FL)
Hanjiao Chen (G)	University of Alabama, Tuscaloosa	USA (AL)
hongfen Yang (G)	University of Florida	USA (FL)
Jin Gao (G)	University of Illinois at Chicago	USA (IL)
Kang Du (G)	Northwestern University	USA (IL)
Kannan Menon (G)	University of Florida	USA (FL)
Lei Fan (G)	University of Florida	USA (FL)
Magdoom Mohamed Kulam Najmudeen (G)	University of Florida	USA (FL)
Manish Amin (G)	University of Florida	USA (FL)
Matthew Burg (G)	University of Florida	USA (FL)
Nicholas Paciaroni (G)	University of Florida	USA (FL)
Prashant Singh (G)	University of Florida	USA (FL)

# Appendix III – Geographic Distribution

Name	Organization	Country
Ran Zuo (G)	University of Florida	USA (FL)
Robert Huigens (G/PI)	University of Florida	USA (FL)
Tan Nyguyen (U)	University of Florida	USA (FL)
Tommy Zhao (G)	University of Florida	USA (FL)
Yasmeen Abouelhassan (G)	University of Florida	USA (FL)
Yi Zhang (G)	University of Florida	USA (FL)
Yong Du (G)	University of Florida	USA (FL)
Yuting Wang (G)	University of Florida	USA (FL)

## 1.1.4. a) Technicians, USA - 6

Name	Organization	Country
Joshua Slade (T)	University of Florida	USA (FL)
Kelly Jenkins (T)	University of Florida	USA (FL)
Kimberly Robertson (T)	University of Florida	USA (FL)
Renuk Lakshmanan (T)	University of Florida	USA (FL)
Tammy Nicholson (T)	University of Florida	USA (FL)
Weiguo Li (T)	University of Illinois at Chicago	USA (IL)

## 1.1. AMRIS Facility – Independently Funded

### 1.1.1. b) Senior Personnel, USA – 90

Name	Organization	Country
Adam Woods (S/PI)	University of Florida	USA (FL)
Alex Greening (S/PI)	University of Florida	USA (FL)
Andreas Keil (S/PI)	University of Florida	USA (FL)
Ann Mislovic (S)	University of Florida	USA (FL)
Annette de Kloet (S)	University of Florida	USA (FL)
Ashok Kumar (S)	University of Florida	USA (FL)
Barry Byrne (S/PI)	University of Florida	USA (FL)
Barry Setlow (S/PI)	University of Florida	USA (FL)
Benjamin Philmus (S/PI)	Oregon State University	USA (OR)
Brian Law (S)	University of Florida	USA (FL)
Caryn Plummer (S)	University of Florida	USA (FL)
Catherine Price (S)	University of Florida	USA (FL)
Charles Frazier (S)	University of Florida	USA (FL)
Chengguo Xing (S/PI)	University of Florida	USA (FL)
Chenglong Li (S/PI)	University of Florida	USA (FL)
Christine Schmidt (S/PI)	University of Florida	USA (FL)
Christopher McCurdy (S/PI)	University of Florida	USA (FL)
Daniel R. Talham (S/PI)	University of Florida	USA (FL)
David Tran (S/PI)	University of Florida	USA (FL)
David Vaillancourt (S/PI)	University of Florida	USA (FL)
Dawn Bowers (S/PI)	University of Florida	USA (FL)
Donovan Lott (S/PI)	University of Florida	USA (FL)
Duane Mitchell (S/PI)	University of Florida	USA (FL)

# Appendix III – Geographic Distribution

<b>Name</b>	<b>Organization</b>	<b>Country</b>
Elias Sayour (S)	University of Florida	USA (FL)
Elisabeth Barton (S/PI)	University of Florida	USA (FL)
Eric Krause (S)	University of Florida	USA (FL)
Fernando Brill (S/PI)	University of Florida	USA (FL)
Glenn Smith (S/PI)	University of Florida	USA (FL)
Glenn Walter (S/PI)	University of Florida	USA (FL)
Hendrik Luesch (S/PI)	University of Florida	USA (FL)
Hideko Kasahara (S/PI)	University of Florida	USA (FL)
Hong Li (S)	Medical University of South Carolina	USA (SC)
Huadong Zeng (S)	University of Florida	USA (FL)
Ion Ghiviriga (S/PI)	University of Florida	USA (FL)
James Rocca (S)	University of Florida	USA (FL)
James Wynn (S/PI)	University of Florida	USA (FL)
Jane Aldrich (S/PI)	University of Florida	USA (FL)
Jeanine Brady (S/PI)	University of Florida	USA (FL)
Jeremy Flint (S/PI)	University of Florida	USA (FL)
Jinhua Song (S)	University of Florida	USA (FL)
Joanna Long (S/PI)	University of Florida	USA (FL)
John Forder (S/PI)	University of Florida	USA (FL)
John Neubert (S/PI)	University of Florida	USA (FL)
John Williamson (S/PI)	University of Florida	USA (FL)
Jon Dobson (S/PI)	University of Florida	USA (FL)
Joseph Riley (S/PI)	University of Florida	USA (FL)
Juan Leon (S)	University of Florida	USA (FL)
K. VANDENBORNE (S/PI)	University of Florida	USA (FL)
Keith White (S/PI)	University of Florida	USA (FL)
Kenneth Cusi (S/PI)	University of Florida	USA (FL)
Lee Sweeney (S/PI)	University of Florida	USA (FL)
Liguang Mao (S)	University of Florida	USA (FL)
Linda Hayward (S)	University of Florida	USA (FL)
Long Dang (S)	University of Florida	USA (FL)
Luke Norton (S/PI)	University of Texas Health Science Center at San Antonio	USA (TX)
Marcelo Febo (S/PI)	University of Florida	USA (FL)
Mark Bishop (S/PI)	University of Florida	USA (FL)
Mark Lewis (S/PI)	University of Florida	USA (FL)
Matthew Merritt (S/PI)	University of Florida	USA (FL)
Meredith Wicklund (S/PI)	University of Florida	USA (FL)
Michael Okun (S)	University of Florida	USA (FL)
Michael Robinson (S/PI)	University of Florida	USA (FL)
Mingzhou Ding (S/PI)	University of Florida	USA (FL)
Mohan Raizada (S/PI)	University of Florida	USA (FL)
Natalie Ebner (S/PI)	University of Florida	USA (FL)
Nichole Lighthall (S/PI)	University of Central Florida	USA (FL)



# Appendix III – Geographic Distribution

Name	Organization	Country
Nicole Horenstein (S/PI)	University of Florida	USA (FL)
Nikolaus McFarland (S)	University of Florida	USA (FL)
Peter Lang (S/PI)	University of Florida	USA (FL)
Robert Cousins (S/PI)	University of Florida	USA (FL)
Roger Fillingim (S/PI)	University of Florida	USA (FL)
Roland Staud (S/PI)	University of Florida	USA (FL)
Ron Cohen (S/PI)	University of Florida	USA (FL)
Ronald Castellano (S/PI)	University of Florida	USA (FL)
Rosalind Sadleir (S/PI)	Arizona State University	USA (AZ)
Russell Bauer (S/PI)	University of Florida	USA (FL)
Sara Burke (S)	University of Florida	USA (FL)
Sara Nixon (S/PI)	University of Florida	USA (FL)
Sergey Vasenkov (S/PI)	University of Florida	USA (FL)
Stephen Coombes (S/PI)	University of Florida	USA (FL)
Steve Blackband (S/PI)	University of Florida	USA (FL)
Thomas Foster (S)	University of Florida	USA (FL)
Thomas Mareci (S/PI)	University of Florida	USA (FL)
Todd Golde (S)	University of Florida	USA (FL)
Valerie Paul (S)	Smithsonian Institution	USA (DC)
Vonetta Dotson (S/PI)	University of Florida	USA (FL)
William R. Kem (S/PI)	University of Florida	USA (FL)
Yenisel Cruz-Almeida (S/PI)	University of Florida	USA (FL)
Yousong Ding (S/PI)	University of Florida	USA (FL)
Zhongwu Guo (S/PI)	University of Florida	USA (FL)

## 1.1.2. b) Postdocs, USA – 34

Name	Organization	Country
Adam Monsalve (P)	University of Florida	USA (FL)
Ali Sirusi Arvij (P)	University of Florida	USA (FL)
Brittney Yegla (P)	University of Florida	USA (FL)
Caitlin Orsini (P)	University of Florida	USA (FL)
christopehr lopez (P)	University of Florida	USA (FL)
Darin Falk (P/PI)	University of Florida	USA (FL)
Edward Ofori (P)	University of Florida	USA (FL)
Eric Porges (P/PI)	University of Florida	USA (FL)
Farhad Dastmalchi (P)	University of Florida	USA (FL)
Gwladys Riviere (P)	University of Florida	USA (FL)
James Collins (P)	University of Florida	USA (FL)
Jasenska Zubcevic (P/PI)	University of Florida	USA (FL)
Katja Hillbrandt (P)	University of Florida	USA (FL)
Kristin Dayton (P/PI)	University of Florida	USA (FL)
Lisa Domenico (P/PI)	University of Florida	USA (FL)
Luis Colon-perez (P)	University of Florida	USA (FL)
Manuela Corti (P/PI)	University of Florida	USA (FL)

# Appendix III – Geographic Distribution

Name	Organization	Country
Maryan Rahman (P/PI)	University of Florida	USA (FL)
Meryl Alappattu (P)	University of Florida	USA (FL)
Monica Tschosik (P)	University of Florida	USA (FL)
Mukundan Ragavan (P/PI)	University of Florida	USA (FL)
Paramita Chakrabarty (P)	University of Florida	USA (FL)
Priyank Shukla (P)	University of Florida	USA (FL)
Qing Zhao (P)	University of Florida	USA (FL)
Qingjiang Li (P)	University of Florida	USA (FL)
Qiyin Chen (P)	University of Florida	USA (FL)
Ram Khattri (P)	University of Florida	USA (FL)
Rebecca Willcocks (P/PI)	University of Florida	USA (FL)
Roxana Burciu (P)	University of Florida	USA (FL)
Sahba Mobini (P)	University of Florida	USA (FL)
Santanu Hati (P)	University of Florida	USA (FL)
Sanyong Zhu (P)	University of Florida	USA (FL)
Sean Forbes (P/PI)	University of Florida	USA (FL)
Sebastiano Intagliata (P)	University of Florida	USA (FL)

## 1.1.3. b) Students, USA – 80

Name	Organization	Country
Abhijit Rajan (G)	University of Florida	USA (FL)
Abhinandan Batra (G)	University of Florida	USA (FL)
Abigail Hatcher (U)	University of Florida	USA (FL)
Adam Grippin (G)	University of Florida	USA (FL)
Aditya Kasinadhuni (G)	University of Florida	USA (FL)
Amanda Garcia (G)	University of Florida	USA (FL)
Asia Cobb (G)	University of Florida	USA (FL)
Asmerom Weldeab (G)	University of Florida	USA (FL)
Benjamin Spearman (G)	University of Florida	USA (FL)
Bradley Wilkes (G)	University of Florida	USA (FL)
Brandon Wummer (U)	University of Florida	USA (FL)
Brittany DeFeis (G)	University of Florida	USA (FL)
Charles Gay (G)	University of Florida	USA (FL)
Charlesynquette Duncan (U)	University of Florida	USA (FL)
Claribel Nunez (G)	University of Florida	USA (FL)
Daniel Downes (G/PI)	University of Florida	USA (FL)
Daniell Fagnani (G)	University of Florida	USA (FL)
Danmeng Luo (G)	University of Florida	USA (FL)
Dan-Tam Nguyen (G)	University of Florida	USA (FL)
Deirdre O'Shea (G)	University of Florida	USA (FL)
Desiree Gulliford (G)	University of Florida	USA (FL)
Evan Forman (G)	University of Florida	USA (FL)
Fabien Emmetiere (G)	University of Florida	USA (FL)
Fatma Al-Awadhi (G)	University of Florida	USA (FL)

# Appendix III – Geographic Distribution

Name	Organization	Country
Guangde Jiang (G)	University of Florida	USA (FL)
Guita Banan (G)	University of Florida	USA (FL)
Ian Frazier (G)	University of Florida	USA (FL)
Jae Woo Chung (G)	University of Florida	USA (FL)
Jeremy Coleman (G)	University of Florida	USA (FL)
Jesse DeSimone (G)	University of Florida	USA (FL)
Jessica Kraft (G)	University of Florida	USA (FL)
Johanna McCracken (U)	University of Florida	USA (FL)
Jolie Barter (G)	University of Florida	USA (FL)
Joseph Gullett (G)	University of Florida	USA (FL)
Kannan Menon (G)	University of Florida	USA (FL)
Karlana Carhill (U)	University of Florida	USA (FL)
Katherine Lubke (G)	University of Florida	USA (FL)
Kelsey Luecke McPherson (G)	University of Florida	USA (FL)
Kimberly Guice (U)	University of Florida	USA (FL)
Korey Cooke (U)	University of Florida	USA (FL)
Kyle Dyson (G)	University of Florida	USA (FL)
Lei Li (G)	University of Florida	USA (FL)
Lei Wang (G)	University of Florida	USA (FL)
Lei Wang (G)	University of Florida	USA (FL)
Lindsay Conner (G)	University of Central Florida	USA (FL)
Liselotte de Wit (G)	University of Florida	USA (FL)
Magdoom Mohamed Kulam Najmudeen (G)	University of Florida	USA (FL)
Manish Amin (G)	University of Florida	USA (FL)
Marilyn Horta (G)	University of Florida	USA (FL)
Marjory Pompilus (G)	University of Florida	USA (PR)
Matthew Hey (U)	University of Florida	USA (FL)
Matthew Williams (G)	University of Florida	USA (FL)
Nathan Petro (G)	University of Florida	USA (FL)
Nhi Tran (G)	University of Florida	USA (FL)
Nicole Nissim (G)	University of Florida	USA (FL)
Nikunj Agrawal (G)	University of Florida	USA (FL)
Ouidad Lahtigui (G)	University of Florida	USA (FL)
Paul Mangal (G)	University of Florida	USA (FL)
Peter Vertesaljai (G)	University of Florida	USA (FL)
Pratik Roy (G/PI)	University of Florida	USA (FL)
Primali Navaratne (G)	University of Florida	USA (FL)
Ravneet Vohra (G)	University of Florida	USA (FL)
Roxanne Rezaei (G)	University of Florida	USA (FL)
Samuel Berens (G)	University of Florida	USA (FL)
Sarah Scott (G)	University of Florida	USA (FL)
Sarah Szymkowicz (G)	University of Florida	USA (FL)
Scott Harden (G)	University of Florida	USA (FL)

# Appendix III – Geographic Distribution

Name	Organization	Country
Siyang Yin (G)	University of Florida	USA (FL)
Solomon Gisemba (G)	University of Florida	USA (FL)
Stephen Chrzanowski (G)	University of Florida	USA (FL)
Susanna McConn (U)	University of Florida	USA (FL)
Tao Yang (G)	University of Florida	USA (FL)
Taylor LeCorgne (G)	University of Florida	USA (FL)
Tyler Wildes (G)	University of Florida	USA (FL)
Verda Agan (U)	University of Florida	USA (FL)
Weijing Cai (G)	University of Florida	USA (FL)
Will Henderson (G)	University of Florida	USA (FL)
Xiaozhi Yang (G)	University of Florida	USA (FL)
Yalun Tan (G)	University of Florida	USA (FL)
Zhenhong Hu (G)	University of Florida	USA (FL)

## 1.1.4. b) Technicians, USA - 35

Name	Organization	Country
Abigail Zulich (T)	University of Florida	USA (FL)
Amanda Slater (T)	University of Florida	USA (FL)
Andres Saavedra (T)	University of Florida	USA (FL)
Andrew O'Shea (T)	University of Florida	USA (FL)
Caitlin McNally (T)	University of Florida	USA (FL)
Cathy Powers (T)	University of Florida	USA (FL)
Danielle Poulton (T)	University of Florida	USA (FL)
Eric Weber (T)	University of Florida	USA (FL)
Gee Kim (T)	University of Florida	USA (FL)
Grace Thompson (T)	University of Florida	USA (FL)
Hector Gonzalez (T)	University of Florida	USA (FL)
Helmut Hiller (T)	University of Florida	USA (FL)
Ian Dalton (T)	University of Central Florida	USA (FL)
Joshua Slade (T)	University of Florida	USA (FL)
Josue Cardoso (T)	University of Florida	USA (FL)
Judith Steadman (T)	University of Florida	USA (FL)
Madison Bryan (T)	University of Florida	USA (FL)
Maria Aguirre (T)	University of Florida	USA (FL)
Marlin Mejia (T)	University of Florida	USA (FL)
Megan Forbes (T)	University of Florida	USA (FL)
Molly McLaren (T)	University of Florida	USA (FL)
Nagheme Thomas (T)	University of Florida	USA (FL)
Paige Lysne (T)	University of Florida	USA (FL)
Phuong Deleyrolle (T)	University of Florida	USA (FL)
Rebecca Morgan (T)	University of Florida	USA (FL)
Riddhi Ramanlal (T)	University of Florida	USA (FL)
Samantha Norman (T)	University of Florida	USA (FL)
Sara Heshmati (T)	University of Florida	USA (FL)

# Appendix III – Geographic Distribution

Name	Organization	Country
Sean Turner (T)	University of Florida	USA (FL)
Tammy Nicholson (T)	University of Florida	USA (FL)
Tatsiana Tsarova (T)	University of Florida	USA (FL)
Tina Cousins (T)	University of Florida	USA (FL)
Ty Redler (T)	University of Florida	USA (FL)
Wendi Malphurs (T)	University of Florida	USA (FL)
Yvette Trahan (T)	University of Florida	USA (FL)

## 1.2. DC Field Facility

### 1.2.1. Senior Personnel, USA - 175

Name	Organization	Country
Abhay Pasupathy (S/PI)	Columbia University	USA (NY)
Aixia Xu (S)	University of Houston	USA (TX)
Alex Smirnov (S/PI)	North Carolina State University	USA (NC)
Alexander Nevzorov (S/PI)	North Carolina State University	USA (NC)
Alexey Suslov (S/PI)	National High Magnetic Field Laboratory (NHMFL)	USA (FL)
Anand Bhattacharya (S/PI)	Argonne National Laboratory	USA (IL)
Andrea Young (S/PI)	University of California, Santa Barbara	USA (CA)
Andrey Podlesnyak (S/PI)	Oak Ridge National Laboratory	USA (TN)
Antal Jakli (S)	Kent State University	USA (OH)
Arkady Shehter (S/PI)	National High Magnetic Field Laboratory (NHMFL)	USA (FL)
Arneil Reyes (S/PI)	National High Magnetic Field Laboratory (NHMFL)	USA (FL)
Audrey Grockowiak (S/PI)	National High Magnetic Field Laboratory (NHMFL)	USA (FL)
Benjamin Hunt (S/PI)	Carnegie Mellon University	USA (PA)
Bin MA (S/PI)	University of Minnesota, Twin Cities	USA (MN)
Bo-Kuai Lai (S/PI)	Lake Shore Cryotronics	USA (OH)
Brad Ramshaw (S/PI)	Cornell University	USA (NY)
Brian Maple (S/PI)	University of California, San Diego	USA (CA)
Bryan Kudisch (S)	Princeton University	USA (NJ)
Bryon Dalton (S/PI)	National High Magnetic Field Laboratory (NHMFL)	USA (FL)
Cedomir Petrovic (S/PI)	Brookhaven National Laboratory	USA (NY)
Chiara Tarantini (S)	National High Magnetic Field Laboratory (NHMFL)	USA (FL)
Chris Landee (S/PI)	Clark University	USA (MA)
Christianne Beekman (S/PI)	National High Magnetic Field Laboratory (NHMFL)	USA (FL)
Chun Ning (Jeanie) Lau (S/PI)	University of California, Riverside	USA (CA)
Clifford Bowers (S/PI)	University of Florida	USA (FL)
Cory Dean (S/PI)	City College of New York	USA (NY)
Dagmar Weickert (S/PI)	National High Magnetic Field Laboratory (NHMFL)	USA (NM)
Daniel Silevitch (S)	University of Chicago	USA (CA)
Darrell Schlom (S)	Cornell University	USA (NY)
David Graf (S/PI)	National High Magnetic Field Laboratory (NHMFL)	USA (FL)
David Hilton (S)	National High Magnetic Field Laboratory (NHMFL)	USA (FL)
David Hilton (S/PI)	University of Alabama, Birmingham	USA (AL)
David Larbalestier (S/PI)	National High Magnetic Field Laboratory (NHMFL)	USA (FL)

# Appendix III – Geographic Distribution

Name	Organization	Country
David Mandrus (S/PI)	University of Tennessee, Knoxville	USA (TN)
David Meyer (S)	Navy Research Lab	USA (DC)
David Young (S/PI)	Louisiana State University	USA (LA)
Debdeep Jena (S/PI)	Cornell University	USA (NY)
Denis Karaiskaj (S/PI)	University of South Florida	USA (FL)
Diyar Talbayev (S/PI)	Tulane University	USA (LA)
Dmitri Maslov (S)	University of Florida	USA (FL)
Dmitry Smirnov (S/PI)	National High Magnetic Field Laboratory (NHMFL)	USA (FL)
Dmytro Abraimov (S/PI)	National High Magnetic Field Laboratory (NHMFL)	USA (FL)
Dragana Popovic (S/PI)	National High Magnetic Field Laboratory (NHMFL)	USA (FL)
Efstratios Manousakis (S)	Florida State University (FSU)	USA (FL)
Eitan Ehrenfreund (S)	University of Utah	USA (UT)
Emanuel Tutuc (S/PI)	University of Texas, Austin	USA (TX)
Emilia Morosan (S/PI)	Rice University	USA (TX)
Eric Bauer (S/PI)	Los Alamos National Laboratory	USA (NM)
Eric Hellstrom (S)	National High Magnetic Field Laboratory (NHMFL)	USA (FL)
Eun Sang Choi (S/PI)	National High Magnetic Field Laboratory (NHMFL)	USA (FL)
Fedor Balakirev (S/PI)	National High Magnetic Field Laboratory (NHMFL)	USA (NM)
Feng Wang (S/PI)	University of California, Berkeley	USA (CA)
Filip Ronning (S/PI)	Los Alamos National Laboratory	USA (NM)
Gang Cao (S/PI)	University of Colorado, Boulder	USA (CO)
Gela Kipshidze (S)	State University of New York at Stony Brook	USA (NY)
Genda Gu (S)	Brookhaven National Laboratory	USA (NY)
George Miller (S)	National High Magnetic Field Laboratory (NHMFL)	USA (FL)
Greg Boebinger (S/PI)	National High Magnetic Field Laboratory (NHMFL)	USA (FL)
Gregory Belenky (S)	State University of New York at Stony Brook	USA (NY)
Haidong Zhou (S/PI)	University of Tennessee, Knoxville	USA (TN)
Hongwoo Baek (S/PI)	National High Magnetic Field Laboratory (NHMFL)	USA (FL)
Huili Xing (S)	Cornell University	USA (NY)
Hung-I Kuo (S)	Lake Shore Cryotronics	USA (OH)
Iain Dixon (S)	National High Magnetic Field Laboratory (NHMFL)	USA (FL)
Igor Kuskovsky (S/PI)	Queens College of CUNY	USA (NY)
Ilya Litvak (S)	National High Magnetic Field Laboratory (NHMFL)	USA (FL)
Ireneusz Miotkowski (S)	Purdue University	USA (IN)
Ivan Hung (S)	National High Magnetic Field Laboratory (NHMFL)	USA (FL)
I-Wei Chen (S/PI)	University of Pennsylvania	USA (PA)
Jack Toth (S)	National High Magnetic Field Laboratory (NHMFL)	USA (FL)
James Gleeson (S/PI)	Kent State University	USA (OH)
James Hone (S/PI)	Columbia University	USA (NY)
Jan Jaroszynski (S/PI)	National High Magnetic Field Laboratory (NHMFL)	USA (FL)
Janice Musfeldt (S/PI)	University of Tennessee, Knoxville	USA (TN)
Jiang Wei (S/PI)	Tulane University	USA (LA)
Jianyi Jiang (S/PI)	National High Magnetic Field Laboratory (NHMFL)	USA (FL)
Jie Shan (S)	Pennsylvania State University	USA (PA)

# Appendix III – Geographic Distribution

Name	Organization	Country
Jin Hu (S/PI)	Tulane University	USA (LA)
John Singleton (S/PI)	National High Magnetic Field Laboratory (NHMFL)	USA (NM)
John Tranquada (S/PI)	Brookhaven National Laboratory	USA (NY)
Johnpierre Paglione (S/PI)	University of Maryland, College Park	USA (MD)
Jonathan Betts (S/PI)	National High Magnetic Field Laboratory (NHMFL)	USA (NM)
Joseph Checkelsky (S/PI)	Massachusetts Institute of Technology	USA (MA)
Ju-Hyun Park (S/PI)	National High Magnetic Field Laboratory (NHMFL)	USA (FL)
Julia Smith (S/PI)	National High Magnetic Field Laboratory (NHMFL)	USA (FL)
Jun Yan (S/PI)	University of Massachusetts	USA (MA)
Jun Zhu (S/PI)	Pennsylvania State University	USA (PA)
Jurek Krzystek (S/PI)	National High Magnetic Field Laboratory (NHMFL)	USA (FL)
Kate Ross (S/PI)	Colorado State University	USA (CO)
Ken West (S)	Princeton University	USA (NJ)
Kenneth Knappenberger (S/PI)	Florida State University (FSU)	USA (FL)
Kin Fai Mak (S/PI)	Pennsylvania State University	USA (PA)
Kirk Baldwin (S)	Princeton University	USA (NJ)
Komalavalli Thirunavukkuarasu (S/PI)	National High Magnetic Field Laboratory (NHMFL)	USA (FL)
Kresimir Rupnik (S/PI)	Louisiana State University	USA (LA)
Lisa Tracy (S)	Sandia National Laboratories	USA (NM)
Lloyd Engel (S/PI)	National High Magnetic Field Laboratory (NHMFL)	USA (FL)
Loren Pfeiffer (S)	Princeton University	USA (NJ)
Lu Li (S/PI)	University of Michigan	USA (MA)
Luis Balicas (S/PI)	National High Magnetic Field Laboratory (NHMFL)	USA (FL)
Mansour Shayegan (S/PI)	Princeton University	USA (NJ)
Marcelo Jaime (S/PI)	National High Magnetic Field Laboratory (NHMFL)	USA (NM)
Maria Tamargo (S)	The City College of New York	USA (NY)
Mark Turnbull (S/PI)	Clark University	USA (MA)
Matthew Grayson (S/PI)	Northwestern University	USA (IL)
Michael Manfra (S)	Nokia Bell Labs	USA (NJ)
Michael Zudov (S/PI)	University of Minnesota, Twin Cities	USA (MN)
Michelle Johannes (S)	U.S. Naval Research Laboratory	USA (DC)
Mike Sumption (S/PI)	Ohio State University	USA (OH)
Ming Yin (S)	Benedict College	USA (SC)
Minhyea Lee (S/PI)	University of Colorado, Boulder	USA (CO)
Mykhaylo Ozerov (S/PI)	National High Magnetic Field Laboratory (NHMFL)	USA (FL)
Myron Salamon (S/PI)	University of Texas, Dallas	USA (IL)
N. Phuan Ong (S/PI)	Princeton University	USA (NJ)
Natalia Drichko (S/PI)	Johns Hopkins University	USA (MD)
Neil Ashcroft (S)	Cornell University	USA (NY)
Neil Harrison (S/PI)	National High Magnetic Field Laboratory (NHMFL)	USA (NM)
Nuh Gedik (S/PI)	Massachusetts Institute of Technology	USA (MA)
Pablo Jarillo-Herrero (S/PI)	Massachusetts Institute of Technology	USA (MA)
Patrick Noyes (S/PI)	National High Magnetic Field Laboratory (NHMFL)	USA (FL)
Paul Cadden-Zimansky (S/PI)	Bard College	USA (NY)

# Appendix III – Geographic Distribution

Name	Organization	Country
Paul McEuen (S/PI)	Cornell University	USA (NY)
Peide Ye (S/PI)	Purdue University	USA (IN)
Philip Kim (S/PI)	Harvard University	USA (MA)
Prasenjit Guptasarma (S/PI)	University of Wisconsin, Milwaukee	USA (WI)
Qi Li (S/PI)	Pennsylvania State University	USA (PA)
R. Ramesh (S/PI)	University of California, Berkeley	USA (CA)
Roald Hoffmann (S)	Cornell University	USA (NY)
Robert Griffin (S/PI)	Massachusetts Institute of Technology	USA (MA)
Rongying Jin (S/PI)	Louisiana State University	USA (LA)
Rongying Jin (S/PI)	Louisiana State University	USA (LA)
Ross McDonald (S/PI)	National High Magnetic Field Laboratory (NHMFL)	USA (NM)
Rui-Rui Du (S/PI)	Rice University	USA (TX)
Ryan Baumbach (S/PI)	National High Magnetic Field Laboratory (NHMFL)	USA (FL)
Sam Sprunt (S/PI)	Kent State University	USA (OH)
Sang Wook Cheong (S/PI)	Rutgers University, New Brunswick	USA (NJ)
Sara Haravifard (S/PI)	Duke University	USA (NC)
Scott Bole (S)	National High Magnetic Field Laboratory (NHMFL)	USA (FL)
Scott Hannahs (S/PI)	National High Magnetic Field Laboratory (NHMFL)	USA (FL)
Scott Katzer (S)	U.S. Naval Research Laboratory	USA (DC)
Seokho Kim (S)	National High Magnetic Field Laboratory (NHMFL)	USA (FL)
Seongshik Oh (S/PI)	Rutgers University, New Brunswick	USA (NJ)
Serge Luryi (S)	State University of New York at Stony Brook	USA (NY)
Sergey Suchalkin (S/PI)	State University of New York at Stony Brook	USA (NY)
Seungyong Hahn (S/PI)	National High Magnetic Field Laboratory (NHMFL)	USA (FL)
Shanti Deemyad (S/PI)	University of Utah	USA (UT)
Stan Tozer (S/PI)	National High Magnetic Field Laboratory (NHMFL)	USA (FL)
Stanimir Bonev (S)	Lawrence Livermore National Laboratory	USA (CA)
Stephen McGill (S/PI)	National High Magnetic Field Laboratory (NHMFL)	USA (FL)
Stephen Nagler (S/PI)	Oak Ridge National Laboratory	USA (TN)
Sufei Shi (S/PI)	Rensselaer Polytechnic Institute	USA (NY)
Sung Seok Seo (S/PI)	University of Kentucky	USA (KY)
Taylor Sparks (S)	University of Utah	USA (UT)
Tim Cross (S/PI)	National High Magnetic Field Laboratory (NHMFL)	USA (FL)
Tim Murphy (S/PI)	National High Magnetic Field Laboratory (NHMFL)	USA (FL)
Timir Datta (S/PI)	University of South Carolina	USA (SC)
Tom Painter (S/PI)	National High Magnetic Field Laboratory (NHMFL)	USA (FL)
Tom Rosenbaum (S/PI)	University of Chicago	USA (IL)
Tony Heinz (S/PI)	Stanford University	USA (CA)
Tzu-Ming Lu (S/PI)	Sandia National Laboratories	USA (NM)
Venkat Selvamanickam (S/PI)	University of Houston	USA (TX)
Vesna Mitrovic (S/PI)	Brown University	USA (RI)
Vikram Deshpande (S/PI)	University of Utah	USA (UT)
William Brey (S/PI)	National High Magnetic Field Laboratory (NHMFL)	USA (FL)
William Coniglio (S/PI)	National High Magnetic Field Laboratory (NHMFL)	USA (FL)



# Appendix III – Geographic Distribution

Name	Organization	Country
William Marshall (S)	National High Magnetic Field Laboratory (NHMFL)	USA (FL)
Xiaoyan Shi (S/PI)	University of Texas, Dallas	USA (TX)
Yasu Takano (S/PI)	University of Florida	USA (FL)
Yong Chen (S/PI)	Purdue University	USA (IN)
Z. Vally Vardeny (S/PI)	University of Utah	USA (UT)
Zahid Hasan (S/PI)	Princeton University	USA (NJ)
Zhehong Gan (S/PI)	National High Magnetic Field Laboratory (NHMFL)	USA (FL)
Zhigang Jiang (S/PI)	Georgia Institute of Technology	USA (GA)
Zhiqiang Mao (S/PI)	Tulane University	USA (LA)
Ziling Xue (S/PI)	University of Tennessee, Knoxville	USA (TN)

## 1.2.2. Postdocs, USA - 62

Name	Organization	Country
Adam Tsen (P)	Columbia University	USA (NY)
Aifeng Wang (P)	Brookhaven National Laboratory	USA (NY)
Anthony Hatke (P)	National High Magnetic Field Laboratory (NHMFL)	USA (FL)
Avishai Benyamini (P)	Columbia University	USA (NY)
Biplob Barman (P)	University of Alabama, Birmingham	USA (AL)
Chuang Zhang (P)	University of Utah	USA (UT)
Dali Sun (P)	University of Utah	USA (UT)
Daniel Rhodes (P)	Columbia University	USA (NY)
Eric Spanton (P)	University of California, Santa Barbara	USA (CA)
Eric Yue Ma (P)	Stanford University	USA (CA)
Fumitake Kametani (P)	National High Magnetic Field Laboratory (NHMFL)	USA (FL)
Gianmarco Bovone (P)	National High Magnetic Field Laboratory (NHMFL)	USA (FL)
Gil-Ho Lee (P)	Harvard University	USA (MA)
Guixin Cao (P)	Louisiana State University	USA (LA)
Guru Khalsa (P)	Cornell University	USA (NY)
Haoliang Zhang (P)	University of South Florida	USA (FL)
Hongcheng Lu (P)	Duke University	USA (NC)
Jasminka Terzic (P)	University of Colorado, Boulder	USA (CO)
Jia Li (P)	Columbia University	USA (NY)
Jin Jung Kweon (P)	National High Magnetic Field Laboratory (NHMFL)	USA (FL)
Joana Paulino (P)	National High Magnetic Field Laboratory (NHMFL)	USA (FL)
Julia Mundy (P)	University of California, Berkeley	USA (CA)
Ke Wang (P)	Harvard University	USA (MA)
Kefeng Wang (P)	University of Maryland, College Park	USA (MD)
Kevin Huang (P)	National High Magnetic Field Laboratory (NHMFL)	USA (FL)
Kristiaan De Greve (P)	Harvard University	USA (MA)
Kwangmin Kim (P)	National High Magnetic Field Laboratory (NHMFL)	USA (FL)
Laurel Stritzinger (P)	National High Magnetic Field Laboratory (NHMFL)	USA (NM)
Liusuo Wu (P)	Oak Ridge National Laboratory	USA (TN)
Long Ju (P)	Cornell University	USA (NY)
Luca Moretti (P)	Princeton University	USA (NJ)

# Appendix III – Geographic Distribution

Name	Organization	Country
Ludi Miao (P)	Pennsylvania State University	USA (PA)
Luis Jauregui (P)	Harvard University	USA (MA)
Margherita Maiuri (P)	Princeton University	USA (NJ)
Martin Gustafsson (P)	Columbia University	USA (NY)
Matthew Yankowitz (P)	Columbia University	USA (NY)
Mun Chan (P/PI)	National High Magnetic Field Laboratory (NHMFL)	USA (NM)
Priscila Ferrari Silveira Rosa (P)	Los Alamos National Laboratory	USA (NM)
Rebeca Ribeiro Palau (P)	Columbia University	USA (NY)
Ruoyu Chen (P)	Ohio State University	USA (OH)
Rusen Yan (P)	Cornell University	USA (NY)
Sabri Elatresh (P)	Cornell University	USA (NY)
Scott Dietrich (P)	Columbia University	USA (NY)
Sergio de la Barrera (P)	Carnegie Mellon University	USA (PA)
Sheng Ran (P)	University of California, San Diego	USA (CA)
Shengwei Jiang (P)	Pennsylvania State University	USA (PA)
Stephen Kuhn (P)	Duke University	USA (NC)
Takehito Suzuki (P)	Massachusetts Institute of Technology	USA (MA)
Terence Bretz-Sullivan (P)	Argonne National Laboratory	USA (IL)
Tingxin Li (P)	Rice University	USA (TX)
Trevor Keiber (P)	University of California, San Diego	USA (CA)
Wenhai Song (P)	University of Colorado, Boulder	USA (CO)
Xiaoling Wang (P)	National High Magnetic Field Laboratory (NHMFL)	USA (FL)
Xiaoxiang Xi (P)	Pennsylvania State University	USA (PA)
Yang Tang (P)	Northwestern University	USA (IL)
You Zhou (P)	Harvard University	USA (MA)
Youngduck Kim (P)	Columbia University	USA (NY)
Younghun Jung (P)	Columbia University	USA (NY)
Yu Liu (P)	Brookhaven National Laboratory	USA (NY)
Zhanybek Alpichshev (P)	Massachusetts Institute of Technology	USA (MA)
Zhenzhong Shi (P)	National High Magnetic Field Laboratory (NHMFL)	USA (FL)
Ziji Xiang (P)	University of Michigan	USA (MI)

## 1.2.3. Students, USA - 181

Name	Organization	Country
Junbo Zhu (G)	Massachusetts Institute of Technology	USA (MA)
Ashlyn Burch (G)	University of Alabama, Birmingham	USA (AL)
Jeremy Curtis (G)	University of Alabama, Birmingham	USA (AL)
Garrison Linn (G)	University of Alabama, Birmingham	USA (AL)
Aidan O'Beirne (U)	University of Alabama, Birmingham	USA (AL)
Joanna Schmidt (U)	University of Alabama, Birmingham	USA (AL)
Alexander Breindel (G)	University of California, San Diego	USA (CA)
Shi Che (G)	University of California, Riverside	USA (CA)
Carlos Kometter (U)	University of California, Santa Barbara	USA (CA)
Naveen Pouse (G)	University of California, San Diego	USA (CA)

# Appendix III – Geographic Distribution

Name	Organization	Country
Petr Stepanov (G)	University of California, Riverside	USA (CA)
Son Tran (G)	University of California, Riverside	USA (CA)
Yishu Wang (G)	California Institute of Technology	USA (CA)
Jiawei Yang (G)	University of California, Riverside	USA (CA)
Haoxin Zhou (G)	University of California, Santa Barbara	USA (CA)
Alexander Zibrov (G)	University of California, Santa Barbara	USA (CA)
Ian Leahy (G)	University of Colorado, Boulder	USA (CO)
Yifei Ni (G)	University of Colorado, Boulder	USA (CO)
Christopher Pocs (G)	University of Colorado, Boulder	USA (CO)
Timothy Reeder (U)	Colorado State University	USA (CO)
Peter Siegfried (G)	University of Colorado, Boulder	USA (CO)
Yu Zhang (G)	University of Colorado, Boulder	USA (CO)
Hengdi Zhao (G)	University of Colorado, Boulder	USA (CO)
Hao Zheng (G)	University of Colorado, Boulder	USA (CO)
Naween Anand (G)	University of Florida	USA (FL)
Paul Baity (G)	National High Magnetic Field Laboratory (NHMFL)	USA (FL)
Kevin Barry (G)	Florida State University (FSU)	USA (FL)
Shermane Benjamin (G)	National High Magnetic Field Laboratory (NHMFL)	USA (FL)
Michael Brown (G)	National High Magnetic Field Laboratory (NHMFL)	USA (FL)
Kuan-Wen Chen (G)	National High Magnetic Field Laboratory (NHMFL)	USA (FL)
Yu Che Chiu (G)	National High Magnetic Field Laboratory (NHMFL)	USA (FL)
Timothy Cox (G)	University of South Florida	USA (FL)
Daniel Davis (G)	National High Magnetic Field Laboratory (NHMFL)	USA (FL)
Matthew Freeman (G)	National High Magnetic Field Laboratory (NHMFL)	USA (FL)
Carlos Garcia (G)	Florida State University (FSU)	USA (FL)
Patrick Herbert (G)	Florida State University (FSU)	USA (FL)
Joshua Holleman (G)	Florida State University (FSU)	USA (FL)
Xinzhe Hu (G)	University of Florida	USA (FL)
Xiujun Iian (G)	National High Magnetic Field Laboratory (NHMFL)	USA (FL)
You Lai (G)	National High Magnetic Field Laboratory (NHMFL)	USA (FL)
Zhengguang Lu (G)	National High Magnetic Field Laboratory (NHMFL)	USA (FL)
Jonathan Ludwig (G)	National High Magnetic Field Laboratory (NHMFL)	USA (FL)
Utsab Mitra (G)	Florida State University (FSU)	USA (FL)
Seonghill Moon (G)	National High Magnetic Field Laboratory (NHMFL)	USA (FL)
Yavuz Oz (G)	National High Magnetic Field Laboratory (NHMFL)	USA (FL)
Jagannath Paul (G)	University of South Florida	USA (FL)
Bal Pokharel (G)	National High Magnetic Field Laboratory (NHMFL)	USA (FL)
Lily Stanley (G)	National High Magnetic Field Laboratory (NHMFL)	USA (FL)
Christopher Stevens (G)	University of South Florida	USA (FL)
John Tokarski (G)	University of Florida	USA (FL)
Swapnil Yadav (G)	University of Florida	USA (FL)
WenKai Zheng (G)	National High Magnetic Field Laboratory (NHMFL)	USA (FL)
Qiong Zhou (G)	National High Magnetic Field Laboratory (NHMFL)	USA (FL)
Yuxuan Jiang (G)	Georgia Institute of Technology	USA (GA)

# Appendix III – Geographic Distribution

Name	Organization	Country
Jeremy Yang (G)	Georgia Institute of Technology	USA (GA)
Yuchen Du (G)	Purdue University	USA (IN)
Gang Qiu (G)	Purdue University	USA (IN)
Yang Xu (G)	Purdue University	USA (IN)
Hong Zhou (G)	Purdue University	USA (IN)
John Connell (G)	University of Kentucky	USA (KY)
John Gruenewald (G)	University of Kentucky	USA (KY)
Oleksandr Korneta (G)	University of Kentucky	USA (KY)
Justin Thompson (G)	University of Kentucky	USA (KY)
Dustin Watts (U)	Berea College	USA (KY)
Silu Huang (G)	Louisiana State University	USA (LA)
Abin Joshy (G)	Tulane University	USA (LA)
Mojammel Alam Khan (G)	Louisiana State University	USA (LA)
Jinyu Liu (G)	Tulane University	USA (LA)
Xue Liu (G)	Tulane University	USA (LA)
Shukai Yu (G)	Tulane University	USA (LA)
Chunlei Yue (G)	Tulane University	USA (LA)
Yanglin Zhu (G)	Tulane University	USA (LA)
Yuan Cao (G)	Massachusetts Institute of Technology	USA (MA)
Shao-Yu Chen (G)	University of Massachusetts	USA (MA)
Aravind Devarakonda (G)	Massachusetts Institute of Technology	USA (MA)
Emre Ergecen (G)	Massachusetts Institute of Technology	USA (MA)
Thomas Goldstein (G)	University of Massachusetts	USA (MA)
Katie Huang (G)	Harvard University	USA (MA)
Andrew Joe (G)	Harvard University	USA (MA)
Xiaomeng Liu (G)	Harvard University	USA (MA)
Jason Luo (G)	Massachusetts Institute of Technology	USA (MA)
Jeff Monroe (G)	Clark University	USA (MA)
Kateryna Pistunova (U)	Harvard University	USA (MA)
Giovanni Scuri (G)	Harvard University	USA (MA)
Andrey Sushko (G)	Harvard University	USA (MA)
Linda Ye (G)	Massachusetts Institute of Technology	USA (MA)
Grace Zhang (U)	Massachusetts Institute of Technology	USA (MA)
Daniel Campbell (G)	University of Maryland, College Park	USA (MD)
Nora Hassan (G)	Johns Hopkins University	USA (MD)
Tomoya Asaba (G)	University of Michigan	USA (MI)
Lu Chen (G)	University of Michigan	USA (MI)
Xlaojun Fu (G)	University of Minnesota, Twin Cities	USA (MI)
Ben Lawson (G)	University of Michigan	USA (MI)
Colin Tinsman (G)	University of Michigan	USA (MI)
Qianhui Shi (G)	University of Minnesota, Twin Cities	USA (MN)
Brodie Popovic (G)	Duke University	USA (NC)
William Steinhardt (G)	Duke University	USA (NC)
Hao Deng (G)	Princeton University	USA (NJ)

# Appendix III – Geographic Distribution

Name	Organization	Country
Tong Gao (G)	Princeton University	USA (NJ)
Sukret Hasdemir (G)	Princeton University	USA (NJ)
Md Shafayat Hossain (G)	Princeton University	USA (NJ)
Dobromir Kamburov (G)	Princeton University	USA (NJ)
Nikesh Koirala (G)	Rutgers University, New Brunswick	USA (NJ)
Sihang Liang (G)	Princeton University	USA (NJ)
Jingjing Lin (G)	Princeton University	USA (NJ)
Yang Liu (G)	Princeton University	USA (NJ)
Mueed M.A. (G)	Princeton University	USA (NJ)
Meng Ma (G)	Princeton University	USA (NJ)
Jisoo Moon (G)	Rutgers University, New Brunswick	USA (NJ)
M.A. Mueed (G)	Princeton University	USA (NJ)
Maryam Salehi (G)	Rutgers University, New Brunswick	USA (NJ)
Pavel Shibayev (G)	Rutgers University, New Brunswick	USA (NJ)
Wudi Wang (G)	Princeton University	USA (NJ)
Kimberly Modic (G/PI)	National High Magnetic Field Laboratory (NHMFL)	USA (NM)
Abhinandan Antony (G)	Columbia University	USA (NY)
Shaowen Chen (G)	Columbia University	USA (NY)
Yanwen Chen (G)	Rensselaer Polytechnic Institute	USA (NY)
Xu Cui (G)	Columbia University	USA (NY)
Isobel Curtin (U)	Bard College	USA (NY)
Vasilios Deligiannakis (G)	The City College of New York	USA (NY)
Carlos Forsythe (G)	Columbia University	USA (NY)
Tony Le (G)	Queens College of CUNY	USA (NY)
Ethan Richman (U)	Bard College	USA (NY)
Mac Selesnick (U)	Bard College	USA (NY)
Dongjea Seo (G)	Columbia University	USA (NY)
En-Min Shih (G)	Columbia University	USA (NY)
Cheng Tan (G)	Columbia University	USA (NY)
Evan Telford (G)	Columbia University	USA (NY)
Suresh Vishwanath (G)	Cornell University	USA (NY)
Da Wang (G)	Columbia University	USA (NY)
Lei Wang (G)	Columbia University	USA (NY)
Tianmeng Wang (G)	Rensselaer Polytechnic Institute	USA (NY)
John Wendt (U)	Bard College	USA (NY)
Rong Wu (G)	Queens College of CUNY	USA (NY)
Yihang Zeng (G)	Columbia University	USA (NY)
Xiaoxiao Zhang (G)	Columbia University	USA (NY)
Emilio Codecido (G)	Ohio State University	USA (OH)
Matthew Murachver (G)	Kent State University	USA (OH)
Rony Saha (G)	<a href="#">Kent State University</a>	USA (OH)
Dmitry Shcherbakov (G)	Ohio State University	USA (OH)
Bailey Bedford (G)	Pennsylvania State University	USA (PA)
Yanhao Dong (G)	University of Pennsylvania	USA (PA)

# Appendix III – Geographic Distribution

Name	Organization	Country
Devashish Gopalan (G)	Carnegie Mellon University	USA (PA)
Kaifei Kang (G)	Pennsylvania State University	USA (PA)
Jing Li (G)	Pennsylvania State University	USA (PA)
Yang Lu (G)	University of Pennsylvania	USA (PA)
Michael Sinko (G)	Carnegie Mellon University	USA (PA)
Egon Sohn (G)	Pennsylvania State University	USA (PA)
Jing Wang (G)	Pennsylvania State University	USA (PA)
Zefang Wang (G)	Pennsylvania State University	USA (PA)
Shuang Wu (G)	University of Pennsylvania	USA (PA)
Zhenxi Yin (G)	Pennsylvania State University	USA (PA)
Rong Cong (G)	Brown University	USA (RI)
Erick Garcia (G)	Brown University	USA (RI)
Wencong Liu (G)	Brown University	USA (RI)
Mohammed Abdi (U)	Benedict College	USA (SC)
Yassine Jaoudi (U)	Benedict College	USA (SC)
Lei Wang (G)	University of South Carolina	USA (SC)
Qiang Chen (G)	University of Tennessee, Knoxville	USA (TN)
Zhiling Dun (G)	University of Tennessee, Knoxville	USA (TN)
Shiyu Fan (G)	University of Tennessee, Knoxville	USA (TN)
Qing Huang (G)	University of Tennessee, Knoxville	USA (TN)
Clay Mings (G)	University of Tennessee, Knoxville	USA (TN)
Duncan Moseley (G)	University of Tennessee, Knoxville	USA (TN)
Ryan Sinclair (G)	University of Tennessee, Knoxville	USA (TN)
Kevin Smith (G)	University of Tennessee, Knoxville	USA (TN)
Shelby Stavretis (G)	University of Tennessee, Knoxville	USA (TN)
Babak Fallahzad (G)	University of Texas, Austin	USA (TX)
Kyoungwan Kim (G)	University of Texas, Austin	USA (TX)
Stefano Larentis (G)	University of Texas, Austin	USA (TX)
Hema Chandra Prakash Movva (G)	University of Texas, Austin	USA (TX)
Xurui Zhang (G)	University of Texas, Dallas	USA (TX)
Jie Zhang (G)	Rice University	USA (TX)
Su Kong Chong (G)	University of Utah	USA (UT)
Ryan McLaughlin (G)	University of Utah	USA (UT)
Cassie (Rong) Zhang (G)	University of Utah	USA (UT)
Lorne Forsythe (G)	University of Wisconsin, Milwaukee	USA (WI)
Uma Garg (G)	University of Wisconsin, Milwaukee	USA (WI)
Yanan Li (G)	University of Wisconsin, Milwaukee	USA (WI)
William Rexhausen (G)	University of Wisconsin, Milwaukee	USA (WI)
Nathaniel Smith (G)	University of Wisconsin, Milwaukee	USA (WI)

## 1.2.4. Technicians, USA - 6

Name	Organization	Country
Ashleigh Francis (T)	National High Magnetic Field Laboratory (NHMFL)	USA (FL)
Dmitry Semenov (T/PI)	National High Magnetic Field Laboratory (NHMFL)	USA (FL)

# Appendix III – Geographic Distribution

Emsley Marks (T)	National High Magnetic Field Laboratory (NHMFL)	USA (FL)
Glover Jones (T)	National High Magnetic Field Laboratory (NHMFL)	USA (FL)
Larry Gordon (T)	National High Magnetic Field Laboratory (NHMFL)	USA (FL)
Scott Maier (T)	National High Magnetic Field Laboratory (NHMFL)	USA (FL)

## 1.3. EMR Facility

### 1.3.1. Senior Personnel, USA – 62

Name	Organization	Country
Andrew Ozarowski (S/PI)	National High Magnetic Field Laboratory (NHMFL)	USA (FL)
Benjamin Wicker (S)	University of Pikeville	USA (KY)
Brian Hales (S/PI)	Louisiana State University	USA (LA)
Brian Hoffman (S/PI)	Northwestern University	USA (IL)
Chris Landee (S/PI)	Clark University	USA (MA)
Christos Lampropoulos (S/PI)	University of North Florida	USA (FL)
Daniel Mindiola (S)	Pennsylvania State University	USA (PA)
David Mandrus (S/PI)	University of Tennessee, Knoxville	USA (TN)
Denis Pelekhov (S)	Ohio State University	USA (OH)
Dmitry Smirnov (S/PI)	National High Magnetic Field Laboratory (NHMFL)	USA (FL)
Elizabeth Stroupe (S/PI)	Florida State University (FSU)	USA (FL)
Ellis Reinherz (S/PI)	Dana-Farber Cancer Institute	USA (MA)
Enrique del Barco (S/PI)	University of Central Florida	USA (FL)
Fengyuan Yang (S/PI)	Ohio State University	USA (OH)
Frederic Mentink (S/PI)	National High Magnetic Field Laboratory (NHMFL)	USA (FL)
George Christou (S/PI)	University of Florida	USA (FL)
Hannah Shafaat (S/PI)	Ohio State University	USA (OH)
Harry Dorn (S/PI)	Virginia Polytechnic Institute and State University	USA (VA)
Ivan Hung (S)	National High Magnetic Field Laboratory (NHMFL)	USA (FL)
Jeffrey Reimer (S/PI)	University of California, Berkeley	USA (CA)
Jeremy Smith (S)	Indiana University	USA (IN)
Jianfeng Cai (S/PI)	University of South Florida	USA (FL)
Jianjun Pan (S/PI)	University of South Florida	USA (FL)
Joanna Long (S/PI)	University of Florida	USA (FL)
Johan van Tol (S/PI)	National High Magnetic Field Laboratory (NHMFL)	USA (FL)
Joshua Telser (S/PI)	Roosevelt University	USA (IL)
Ju-Hyun Park (S/PI)	National High Magnetic Field Laboratory (NHMFL)	USA (FL)
Junichiro Kono (S/PI)	Rice University	USA (TX)
Jurek Krzystek (S/PI)	National High Magnetic Field Laboratory (NHMFL)	USA (FL)
Kate Ross (S/PI)	Colorado State University	USA (CO)
Kevin Huang (S/PI)	University of South Carolina	USA (SC)
Komalavalli Thirunavukkuarasu (S/PI)	National High Magnetic Field Laboratory (NHMFL)	USA (FL)
Likai Song (S/PI)	National High Magnetic Field Laboratory (NHMFL)	USA (FL)
Linda Columbus (S/PI)	University of Virginia	USA (VA)
Linda Doerrer (S/PI)	Boston University	USA (MA)
Lloyd Lumata (S/PI)	University of Texas, Dallas	USA (TX)
Luis Balicas (S/PI)	National High Magnetic Field Laboratory (NHMFL)	USA (FL)

# Appendix III – Geographic Distribution

Name	Organization	Country
Marcelo Jaime (S/PI)	National High Magnetic Field Laboratory (NHMFL)	USA (NM)
Michael Shatruk (S/PI)	National High Magnetic Field Laboratory (NHMFL)	USA (FL)
Mohindar Seehra (S/PI)	West Virginia University	USA (WV)
Naresh Dalal (S/PI)	National High Magnetic Field Laboratory (NHMFL)	USA (FL)
P. Hammel (S)	Ohio State University	USA (OH)
Pere Miro Ramirez (S)	University of North Florida	USA (FL)
Peter Qin (S/PI)	University of Southern California	USA (CA)
Philip Kim (S/PI)	Harvard University	USA (MA)
R. Britt (S/PI)	University of California, Davis	USA (CA)
Roberto De Guzman (S/PI)	University of Kansas	USA (KS)
Sang Wook Cheong (S/PI)	Rutgers University, New Brunswick	USA (NJ)
Sebastian Stoian (S)	University of Idaho	USA (ID)
Srinivasa Rao Singamaneni (S/PI)	University of Texas, El Paso	USA (TX)
Stefan Stoll (S/PI)	University of Washington	USA (WA)
Stephen Hill (S/PI)	National High Magnetic Field Laboratory (NHMFL)	USA (FL)
Stephen Nagler (S/PI)	Oak Ridge National Laboratory	USA (TN)
Sufei Shi (S/PI)	Rensselaer Polytechnic Institute	USA (NY)
Sungsool Wi (S/PI)	National High Magnetic Field Laboratory (NHMFL)	USA (FL)
Tim Cross (S/PI)	National High Magnetic Field Laboratory (NHMFL)	USA (FL)
Tina Salguero (S/PI)	University of Georgia	USA (GA)
Trevor Hayton (S)	University of California, Santa Barbara	USA (CA)
William DeGrado (S/PI)	University of California, San Francisco	USA (CA)
Zhehong Gan (S/PI)	National High Magnetic Field Laboratory (NHMFL)	USA (FL)
Zhigang Jiang (S/PI)	Georgia Institute of Technology	USA (GA)
Ziling Xue (S/PI)	University of Tennessee, Knoxville	USA (TN)

## 1.3.2. Postdocs, USA – 15

Name	Organization	Country
Adam Smith (P)	University of Florida	USA (FL)
Ajay Aharma (P)	Northwestern University	USA (IL)
Andhika Kiswandhi (P)	University of Texas, Dallas	USA (TX)
Bimala Lama (P)	University of Florida	USA (FL)
Harikrishnan Nair (P)	Colorado State University	USA (CO)
Inhee Lee (P)	Ohio State University	USA (OH)
Johannes McKay (P)	Keysight Technologies	USA (CA)
Joscha Nehr Korn (P/PI)	Florida State University (FSU)	USA (FL)
Jun Xu (P)	University of California, Berkeley	USA (CA)
Luis Jauregui (P)	Harvard University	USA (MA)
Russell Maier (P/PI)	National Institute of Standards and Technology	USA (MD)
Shao-Qing Zhang (P)	University of California, San Francisco	USA (CA)
Thierry Dubroca (P)	National High Magnetic Field Laboratory (NHMFL)	USA (FL)
Xiaoling Wang (P)	National High Magnetic Field Laboratory (NHMFL)	USA (FL)
Zhipeng Li (P)	Rensselaer Polytechnic Institute	USA (NY)



# Appendix III – Geographic Distribution

## 1.3.3. Students, USA – 50

Name	Organization	Country
Adeline Fournet (G)	University of Florida	USA (FL)
Adewale Akinfaderin (G)	Florida State University (FSU)	USA (FL)
Alexandra Patron (U)	University of North Florida	USA (FL)
Andrew Joe (G)	Harvard University	USA (MA)
Anne Hickey (G)	Indiana University	USA (IN)
Chloe Chicola (U)	University of North Florida	USA (FL)
Christopher Parish (G)	University of Texas, Dallas	USA (TX)
Clay Mings (G)	University of Tennessee, Knoxville	USA (TN)
Darrah Johnson-McDaniel (G)	University of Georgia	USA (GA)
Dorsa Komijani (G)	National High Magnetic Field Laboratory (NHMFL)	USA (FL)
Duncan Moseley (G)	University of Tennessee, Knoxville	USA (TN)
Effie Miller (G)	Ohio State University	USA (OH)
Emily Frederick (U)	University of North Florida	USA (FL)
Emily Norwine (U)	Boston University	USA (MA)
Eric Williams (U)	University of North Florida	USA (FL)
Jacob Bryant (U)	University of North Florida	USA (FL)
Jacob Henebry (U)	Boston University	USA (MA)
Jasleen Bindra (G)	National High Magnetic Field Laboratory (NHMFL)	USA (FL)
Jennifer Ruliffson (U)	University of North Florida	USA (FL)
Jessica Elinburg (G)	Boston University	USA (MA)
Joel Serrano (U)	University of North Florida	USA (FL)
John Haddock (G)	Florida State University (FSU)	USA (FL)
Jonathan Marbey (G)	National High Magnetic Field Laboratory (NHMFL)	USA (FL)
Jorge Martinez (G)	Indiana University	USA (IN)
Jose Pagan (U)	University of North Florida	USA (FL)
Kai Lister (U)	University of North Florida	USA (FL)
Kateryna Pistunova (U)	Harvard University	USA (MA)
Katye Poole (G)	University of Florida	USA (FL)
Lauren Grant (G)	Pennsylvania State University	USA (PA)
Marisa Cepeda (U)	Florida State University (FSU)	USA (FL)
Marissa Kieber (G)	University of Virginia	USA (VA)
Michelle Glaze (U)	University of North Florida	USA (FL)
Muhandis Muhandis (G)	National High Magnetic Field Laboratory (NHMFL)	USA (FL)
Nandita Abhyankar (G)	Florida State University (FSU)	USA (FL)
Nathan Peek (G)	National High Magnetic Field Laboratory (NHMFL)	USA (FL)
Peter Niedbalski (G)	University of Texas, Dallas	USA (TX)
Priyanka Vaidya (G)	University of Central Florida	USA (FL)
Samuel Greer (G)	National High Magnetic Field Laboratory (NHMFL)	USA (FL)
Sankalpa Chakraborty (G)	Florida State University (FSU)	USA (FL)
Seonghill Moon (G)	National High Magnetic Field Laboratory (NHMFL)	USA (FL)
Shannon McPherson (U)	University of North Florida	USA (FL)
Shelby Stavretis (G)	University of Tennessee, Knoxville	USA (TN)
Steven Stone (U)	University of North Florida	USA (FL)

# Appendix III – Geographic Distribution

Name	Organization	Country
Thorson Bastien (U)	University of North Florida	USA (FL)
Tianmeng Wang (G)	Rensselaer Polytechnic Institute	USA (NY)
Victor da Cruz Pinha Barbosa (U)	University of North Florida	USA (FL)
Yu Che Chiu (G)	National High Magnetic Field Laboratory (NHMFL)	USA (FL)
Yuxuan Jiang (G)	Georgia Institute of Technology	USA (GA)
Zachary Tener (G)	Florida State University (FSU)	USA (FL)
Zhengguang Lu (G)	National High Magnetic Field Laboratory (NHMFL)	USA (FL)

## 1.3.4. Technicians, USA - 1

Name	Organization	Country
Devon Loughran (T)	University of North Florida	USA (FL)

## 1.4. High B/T Facility

### 1.4.1. Senior Personnel, USA – 7

Name	Organization	Country
Jian-sheng Xia (S)	University of Florida	USA (FL)
Ken West (S)	Princeton University	USA (NJ)
Loren Pfeiffer (S)	Princeton University	USA (NJ)
Mark Meisel (S/PI)	University of Florida	USA (FL)
Nicholas Curro (S/PI)	University of California, Davis	USA (CA)
Robert Hallock (S/PI)	University of Massachusetts	USA (MA)
Xuan Gao (S/PI)	Case Western Reserve University	USA (OH)

### 1.4.2. Postdocs, USA – 3

Name	Organization	Country
Alessandro Serafin (P)	University of Florida	USA (FL)
Andrew Woods (P)	University of Florida	USA (FL)
Liang Yin (P/PI)	University of Florida	USA (FL)

### 1.4.3. Students, USA – 3

Name	Organization	Country
Blaine Bush (G)	University of California, Davis	USA (CA)
Ning Lu (G)	University of South Carolina	USA (SC)
Thomas Crawford (G/PI)	University of South Carolina	USA (SC)

### 1.4.4. Technicians, USA - 0

## 1.5. ICR Facility

### 1.5.1. Senior Personnel, USA – 126

Name	Organization	Country
Alan Marshall (S/PI)	National High Magnetic Field Laboratory (NHMFL)	USA (FL)
Alan Rockwood (S)	University of Utah	USA (UT)
Alison Scott (S)	University of Maryland, Baltimore	USA (MD)
Amy Clingenpeel (S)	Exxon Mobil	USA (NJ)

# Appendix III – Geographic Distribution

Name	Organization	Country
Amy McKenna (S/PI)	National High Magnetic Field Laboratory (NHMFL)	USA (FL)
Andrew Schmidt (S)	Pacific Northwest National Laboratory	USA (WA)
Andrew Yen (S/PI)	Nalco Energy Services	USA (TX)
Angel Ruacho (S)	University of California, San Diego	USA (CA)
Anthony Mennito (S)	Exxon Mobil	USA (NJ)
Archana Agarwal (S/PI)	University of Utah	USA (UT)
Arpad Somogyi (S)	Ohio State University	USA (OH)
Ashley Wittrig (S/PI)	Exxon Mobil	USA (NJ)
Basil Nikolau (S)	Iowa State University	USA (IA)
Benjamin Abbott (S/PI)	Michigan State University	USA (MI)
Bob Swarthout (S/PI)	Appalachian State University	USA (NC)
Borries Demeler (S)	UT Health San Antonio	USA (TX)
Brett Poulin (S/PI)	U.S. Geological Survey	USA (CO)
Brian Miller (S/PI)	Florida State University (FSU)	USA (FL)
Carol Nilsson (S/PI)	University of Texas Medical Branch	USA (TX)
Cassandra Thomas (S)	South Florida Water Management District	USA (FL)
Chad Weisbrod (S/PI)	National High Magnetic Field Laboratory (NHMFL)	USA (FL)
Chris Hendrickson (S/PI)	National High Magnetic Field Laboratory (NHMFL)	USA (FL)
Chris Reddy (S/PI)	Woods Hole Oceanographic Institution	USA (MA)
Christine Foreman (S/PI)	Montana State University	USA (MT)
Christopher Mullen (S)	Thermo Fisher Scientific	USA (CA)
Claire Till (S)	Humboldt State	USA (CA)
Daniel Repeta (S/PI)	Woods Hole Oceanographic Institution	USA (MA)
Dave Valentine (S/PI)	University of California, Santa Barbara	USA (CA)
David Barnidge (S/PI)	Mayo Clinic, Rochester	USA (MN)
David Goodlett (S/PI)	University of Maryland, Baltimore	USA (MD)
David Herold (S)	University of California, San Diego	USA (CA)
David Murray (S)	Mayo Clinic	USA (MN)
David Podgorski (S/PI)	University of New Orleans	USA (LA)
Dennis Phillips (S)	University of Georgia	USA (GA)
Donald Hunt (S/PI)	University of Virginia	USA (VA)
Donald Smith (S/PI)	National High Magnetic Field Laboratory (NHMFL)	USA (FL)
Eve Wurtele (S)	Iowa State University	USA (IA)
Fernando Rosario-Ortiz (S/PI)	University of Colorado, Boulder	USA (CO)
Ford Ballantyne (S)	University of Georgia	USA (GA)
Ge Yu (S)	Florida State University (FSU)	USA (FL)
George Aiken (S/PI)	U.S. Geological Survey	USA (CO)
Gheorghe Bota (S/PI)	Ohio University	USA (OH)
Greg Blakney (S)	National High Magnetic Field Laboratory (NHMFL)	USA (FL)
Greg Wylie (S)	University of Georgia	USA (GA)
H. Edward Chelette (S)	Northwest Florida Water Management District	USA (FL)
Harold Kroto (S/PI)	Florida State University (FSU)	USA (FL)
Heath Fleming (S/PI)	HK Petroleum, Ltd.	USA (FL)
Henderson Cleaves (S/PI)	Institute for Advanced Study	USA (NJ)

# Appendix III – Geographic Distribution

Name	Organization	Country
Henry Williams (S/PI)	Florida Agricultural and Mechanical University	USA (FL)
Hong Li (S/PI)	Florida State University (FSU)	USA (FL)
Huan Chen (S/PI)	National High Magnetic Field Laboratory (NHMFL)	USA (FL)
Huan He (S)	IMB, FSU	USA (FL)
Igor Alabugin (S/PI)	Florida State University (FSU)	USA (FL)
Jackie Jarvis (S/PI)	New Mexico State University	USA (NM)
James Murphy (S)	Yale University	USA (CT)
Jamila Horabin (S/PI)	Florida State University (FSU)	USA (FL)
Jean-Jacques Dunyach (S)	Thermo Fisher Scientific	USA (CA)
Jeffrey Shabanowitz (S)	University of Virginia	USA (VA)
Jeremy Gunawardena (S)	Harvard University	USA (MA)
Jim Bruce (S/PI)	University of Washington	USA (WA)
John Syka (S/PI)	Thermo Fisher Scientific	USA (VA)
Jonathan Amster (S/PI)	University of Georgia	USA (GA)
Joseph Boyer (S)	Plymouth State University	USA (NH)
Joseph Greer (S)	Northwestern University	USA (IL)
Joseph Suflita (S/PI)	University of Oklahoma	USA (OK)
Juan Chavez (S)	University of Washington	USA (WA)
Juliana D'Andrilli (S/PI)	Montana State University	USA (MT)
Junkoo Park (S)	Georgia Gwinnett College	USA (GA)
Justin Billing (S)	Pacific Northwest National Laboratory	USA (WA)
Kaelin Cawley (S)	University of Colorado, Boulder	USA (CO)
Karen Frey (S/PI)	Clark University	USA (MA)
Katherine Barbeau (S)	University of California, San Diego	USA (CA)
Kenneth Bruland (S)	University of California, Santa Cruz	USA (CA)
Kimberly Wickland (S/PI)	U.S. Geological Survey	USA (CO)
Krisztina Varga (S)	University of Wyoming	USA (WY)
Lei Bruschweiler-Li (S)	Ohio State University	USA (OH)
Lissa Anderson (S/PI)	National High Magnetic Field Laboratory (NHMFL)	USA (FL)
Luis Echegoyen (S/PI)	University of Texas, El Paso	USA (TX)
Mak Saito (S)	Woods Hole Oceanographic Institution	USA (MA)
Mary Ann Moran (S)	University of Georgia	USA (GA)
Matthew Tarr (S/PI)	University of New Orleans	USA (LA)
Michelle Arbeitman (S/PI)	Florida State University (FSU)	USA (FL)
Nate Kaiser (S/PI)	National High Magnetic Field Laboratory (NHMFL)	USA (FL)
Neil Kelleher (S/PI)	Northwestern University	USA (IL)
Ni-Bin Chang (S/PI)	University of Central Florida	USA (FL)
Oliva Pisani (S/PI)	Florida International University	USA (FL)
Omics LLC (S/PI)	Omics, LLC	USA (FL)
Paige Novak (S/PI)	University of Minnesota, Twin Cities	USA (MN)
Pamela Vaughan (S/PI)	University of West Florida	USA (FL)
Patricia Medeiros (S/PI)	University of Georgia	USA (GA)
Paul Dunk (S)	National High Magnetic Field Laboratory (NHMFL)	USA (FL)
Paul Thomas (S)	Northwestern University	USA (IL)

# Appendix III – Geographic Distribution

Name	Organization	Country
Priscila Lalli (S)	National High Magnetic Field Laboratory (NHMFL)	USA (FL)
Rafael Bruschweiler (S/PI)	Ohio State University	USA (OH)
Randelle Bundy (S)	Woods Hole Oceanographic Institution	USA (MA)
Renato Castelao (S)	University of Georgia	USA (GA)
Richard Hallen (S)	Pacific Northwest National Laboratory	USA (WA)
Richard LeDuc (S)	Northwestern University	USA (IL)
Robert Ernst (S)	University of Maryland, Baltimore	USA (MD)
Robert Nelson (S/PI)	Woods Hole Oceanographic Institution	USA (MA)
Robert Spencer (S/PI)	Florida State University (FSU)	USA (FL)
Robert Young (S/PI)	Colorado State University	USA (CO)
Rudolf Jaffe (S/PI)	Florida International University	USA (FL)
Ryan Fellers (S)	Northwestern University	USA (IL)
Ryan Hartman (S/PI)	New York University	USA (NY)
Ryan Rodgers (S/PI)	National High Magnetic Field Laboratory (NHMFL)	USA (FL)
Sarah Hughes (S)	Shell Canada	USA (TX)
Sean Harshman (S/PI)	Air Force Research Laboratory	USA (OH)
Sebastian Behrens (S)	University of Minnesota, Twin Cities	USA (MN)
Steven Rowland (S)	National High Magnetic Field Laboratory (NHMFL)	USA (FL)
Susan Pedigo (S/PI)	University of Mississippi	USA (MS)
Tanner Schaub (S/PI)	New Mexico State University	USA (NM)
Teresa Coley (S)	South Florida Water Management District	USA (FL)
Thomas Borch (S/PI)	Colorado State University	USA (CO)
Thomas Manning (S/PI)	Valdosta State University	USA (GA)
TuKiet Lam (S/PI)	Yale University	USA (CT)
Venkata Nevi (S)	Oak Ridge National Laboratory	USA (TN)
Vladislav Lobodin (S)	National High Magnetic Field Laboratory (NHMFL)	USA (FL)
Wade Jeffrey (S)	University of West Florida	USA (FL)
William Cooper (S/PI)	Florida State University (FSU)	USA (FL)
William McDowell (S/PI)	University of New Hampshire	USA (NH)
William Whitman (S)	University of Georgia	USA (GA)
Xiaofeng Li (S)	Yale University	USA (CT)
Yi Zuo (S)	Chevron, San Ramon	USA (CA)
Yuri Corilo (S/PI)	National High Magnetic Field Laboratory (NHMFL)	USA (FL)
Zhiyong Ren (S/PI)	University of Colorado, Boulder	USA (CO)

## 1.5.2. Postdocs, USA – 18

Name	Organization	Country
Adam Wymore (P)	University of New Hampshire	USA (NH)
Anne Kellerman (P)	Florida State University (FSU)	USA (FL)
Ashley Coble (P)	University of New Hampshire	USA (NH)
Caroline DeHart (P)	Northwestern University	USA (IL)
Christoph Aeppli (P/PI)	Woods Hole Oceanographic Institution	USA (MA)
Dawei Li (P)	Florida State University (FSU)	USA (FL)
Emma Spencer (P)	Florida State University (FSU)	USA (FL)

# Appendix III – Geographic Distribution

Name	Organization	Country
Grisel Fierros Romero (P)	Florida Agricultural and Mechanical University	USA (FL)
Huan Wang (P)	University of Colorado, Boulder	USA (CO)
Lu Lu (P)	University of Colorado, Boulder	USA (CO)
Marc Mulet Gas (P)	National High Magnetic Field Laboratory (NHMFL)	USA (FL)
Martha Chacon (P/PI)	National High Magnetic Field Laboratory (NHMFL)	USA (FL)
Michelle English (P)	University of Virginia	USA (VA)
Peng Jin (P)	Ohio University	USA (OH)
Phoebe Zito (P/PI)	Florida State University (FSU)	USA (FL)
Rajneesh Jaswal (P)	Florida Agricultural and Mechanical University	USA (FL)
Rene Boiteau (P)	Woods Hole Oceanographic Institution	USA (MA)
Yun Yu (P/PI)	University of Colorado, Boulder	USA (CO)

## 1.5.3. Students, USA – 57

Name	Organization	Country
Alexander Scherer (G)	Yale University	USA (CT)
Amanda Hohner (G)	University of Colorado, Boulder	USA (CO)
Amy Clingenpeel (G)	National High Magnetic Field Laboratory (NHMFL)	USA (FL)
Andrew McCabe (G)	University of Minnesota, Twin Cities	USA (MN)
Anthony KOleske (G)	Yale University	USA (CT)
Ashley Deverteuil (U)	National High Magnetic Field Laboratory (NHMFL)	USA (FL)
Benjamin Oyler (G)	University of Maryland, Baltimore	USA (MD)
Bianca Rodriguez-Cardona (G)	University of New Hampshire	USA (NH)
Brett Farran (U)	University of West Florida	USA (FL)
Brian Harriman (G)	University of Oklahoma	USA (OK)
Cameron Davis (U)	National High Magnetic Field Laboratory (NHMFL)	USA (FL)
Carlos Romero (G)	Montana State University	USA (MT)
Casey Luzius (G)	Florida State University (FSU)	USA (FL)
Cheng Wang (G)	The Ohio State University	USA (OH)
Dan Wen (G)	University of Central Florida	USA (FL)
David Buck (G)	University of Texas, El Paso	USA (TX)
Edison Castro (G)	University of Texas, El Paso	USA (TX)
Elizabeth Duselis (G)	University of Virginia	USA (VA)
Hanna Temme (G)	University of Minnesota, Twin Cities	USA (MN)
Heidi Smith (G)	Montana State University	USA (MT)
Jonathan Putman (G)	National High Magnetic Field Laboratory (NHMFL)	USA (FL)
Joshua Driver (G)	University of Georgia	USA (GA)
Joshua Johnson (U)	Gardner-Webb University	USA (NC)
Julie Korak (G)	University of Colorado, Boulder	USA (CO)
Korth Elliott (G)	University of New Hampshire	USA (NH)
Kyle Wilkerson (U)	Valdosta State University	USA (GA)
Lidong He (G)	National High Magnetic Field Laboratory (NHMFL)	USA (FL)
Lizzie Grater (U)	Florida State University (FSU)	USA (FL)
Logan Krajewski (G)	National High Magnetic Field Laboratory (NHMFL)	USA (FL)
Lydia Babcock-Adams (G)	University of Georgia	USA (GA)

# Appendix III – Geographic Distribution

Name	Organization	Country
Maira Cerón (G)	University of Texas, El Paso	USA (TX)
Maria Letourneau (G)	University of Georgia	USA (GA)
Markus Dieser (G)	Montana State University	USA (MT)
Megan Behnke (G)	Florida State University (FSU)	USA (FL)
Nicholas Hartshorn (G)	University of Central Florida	USA (FL)
Nicholas Hawco (G)	Woods Hole Oceanographic Institution	USA (MA)
Peilu Liu (G)	Florida State University (FSU)	USA (FL)
Rebecca Kamerman (U)	University of West Florida	USA (FL)
Rebecca Ware (G)	National High Magnetic Field Laboratory (NHMFL)	USA (FL)
Sadie Textor (U)	Florida State University (FSU)	USA (FL)
Samantha Davila (G)	University of Mississippi	USA (MS)
Sarah Johnston (G)	National High Magnetic Field Laboratory (NHMFL)	USA (FL)
Shaoxiong Tian (G)	Florida State University (FSU)	USA (FL)
Shawn Sternisha (G)	Florida State University (FSU)	USA (FL)
Sydney Niles (G)	National High Magnetic Field Laboratory (NHMFL)	USA (FL)
Sydney Plummer (U)	Valdosta State University	USA (GA)
Tashiema Wilson (U)	University of West Florida	USA (FL)
Tessa Bartges (U/PI)	National High Magnetic Field Laboratory (NHMFL)	USA (FL)
Tingting Jiang (G)	National High Magnetic Field Laboratory (NHMFL)	USA (FL)
Travis Drake (G)	Florida State University (FSU)	USA (FL)
Travis Drake (G)	Florida State University (FSU)	USA (FL)
Trevor Harris (G)	Florida State University (FSU)	USA (FL)
William Bahureksa (G)	Colorado State University	USA (CO)
Yeqing Tao (G)	National High Magnetic Field Laboratory (NHMFL)	USA (FL)
Yinghui Wang (G)	Florida State University (FSU)	USA (FL)
Yongqiang Zhou (G)	Florida State University (FSU)	USA (FL)
Yu Zhao (G)	Florida State University (FSU)	USA (FL)

## 1.5.4. Technicians, USA – 8

Name	Organization	Country
Jie Lu (T/PI)	National High Magnetic Field Laboratory (NHMFL)	USA (FL)
John Quinn (T)	National High Magnetic Field Laboratory (NHMFL)	USA (FL)
Manhoi Hur (T/PI)	Iowa State University	USA (IA)
Melissa Hagy (T)	University of West Florida	USA (FL)
Piyush Khopkar (T)	Blue Marble Space Institute of Science	USA (WA)
Shawn Moseley (T)	Florida State University (FSU)	USA (FL)
Ursula Olcese (T)	Florida State University (FSU)	USA (FL)
Winston Robbins (T)	Win Consulting Services	USA (ME)

## 1.6. NMR Facility

### 1.6.1. Senior Personnel, USA – 120

Name	Organization	Country
A. Dean Sherry (S/PI)	University of Texas, Southwestern	USA (TX)

# Appendix III – Geographic Distribution

Name	Organization	Country
Abigail Flores (S)	University of Miami	USA (FL)
Alex Smirnov (S/PI)	North Carolina State University	USA (NC)
Alexander Nevzorov (S/PI)	North Carolina State University	USA (NC)
Anant Paravastu (S/PI)	Georgia Institute of Technology	USA (GA)
Art Edison (S/PI)	University of Georgia	USA (GA)
Benito Marinas (S/PI)	University of Illinois at Urbana-Champaign	USA (IL)
Bo Chen (S/PI)	University of Central Florida	USA (FL)
Bradley Chmelka (S/PI)	University of California, Santa Barbara	USA (CA)
Bruce Bunnell (S/PI)	Tulane University	USA (LA)
Candace Chan (S)	Arizona State University	USA (AZ)
Carl Goodman (S)	Florida Agricultural and Mechanical University	USA (FL)
Carlos Garcia (S/PI)	Clemson University	USA (SC)
Cathy Levenson (S/PI)	Florida State University (FSU)	USA (FL)
Cecil Dybowski (S/PI)	University of Delaware	USA (DE)
Chang Ryu (S/PI)	Rensselaer Polytechnic Institute	USA (NY)
Chi-yuan Cheng (S/PI)	Colgate-Palmolive Company	USA (NJ)
Christina Tang (S/PI)	Virginia Commonwealth University	USA (VA)
Chulsung Bae (S/PI)	Rensselaer Polytechnic Institute	USA (NY)
Clifford Bowers (S/PI)	University of Florida	USA (FL)
David Hilton (S)	National High Magnetic Field Laboratory (NHMFL)	USA (FL)
David Larbalestier (S/PI)	National High Magnetic Field Laboratory (NHMFL)	USA (FL)
Denis Markiewicz (S/PI)	National High Magnetic Field Laboratory (NHMFL)	USA (FL)
Dmitry Ostrovsky (S)	University of Alaska, Anchorage	USA (AK)
Douglas Keszler (S)	Oregon State University	USA (OR)
Douglas Kojetin (S/PI)	The Scripps Research Institute - Florida	USA (FL)
Eduard Chekmenev (S/PI)	Vanderbilt University	USA (TN)
Edward Agyare (S/PI)	Florida Agricultural and Mechanical University	USA (FL)
Elan Eisenmesser (S/PI)	University of Colorado, Denver	USA (CO)
Fang Tian (S/PI)	Pennsylvania State University	USA (PA)
Frederic Mentink (S/PI)	National High Magnetic Field Laboratory (NHMFL)	USA (FL)
George Miller (S)	National High Magnetic Field Laboratory (NHMFL)	USA (FL)
George Scherer (S)	Princeton University	USA (NJ)
Gianluigi Veglia (S/PI)	University of Minnesota, Twin Cities	USA (MN)
Hadi Mohammadigoushki (S/PI)	Florida State University (FSU)	USA (FL)
Hailong Chen (S/PI)	Georgia Institute of Technology	USA (GA)
Harry Dorn (S/PI)	Virginia Polytechnic Institute and State University	USA (VA)
Helena Hagelin-Weaver (S)	University of Florida	USA (FL)
Huan-Xiang Zhou (S/PI)	University of Illinois at Chicago	USA (IL)
Hubert Yin (S/PI)	University of Colorado, Boulder	USA (CO)
Hubertus Weijers (S/PI)	National High Magnetic Field Laboratory (NHMFL)	USA (FL)
Ilya Litvak (S)	National High Magnetic Field Laboratory (NHMFL)	USA (FL)
Ivan Hung (S)	National High Magnetic Field Laboratory (NHMFL)	USA (FL)
Jack Toth (S)	National High Magnetic Field Laboratory (NHMFL)	USA (FL)
James Guest (S/PI)	University of Miami	USA (FL)



# Appendix III – Geographic Distribution

Name	Organization	Country
James Weaver (S)	Harvard University	USA (MA)
Jeffrey Schiano (S)	Pennsylvania State University	USA (PA)
Jens Rosenberg (S)	National High Magnetic Field Laboratory (NHMFL)	USA (FL)
Jeremy Flint (S/PI)	University of Florida	USA (FL)
Jimin Ren (S)	University of Texas, Southwestern	USA (TX)
Joanna Long (S/PI)	University of Florida	USA (FL)
Johan van Tol (S/PI)	National High Magnetic Field Laboratory (NHMFL)	USA (FL)
John Forder (S/PI)	University of Florida	USA (FL)
Johnny Grace (S)	U.S. Department of Agriculture	USA (FL)
Jose Pinto (S/PI)	Florida State University (FSU)	USA (FL)
Joseph Ippolito (S/PI)	Washington University School of Medicine in St. Louis	USA (MO)
Juan Solano (S)	University of Miami	USA (FL)
Justin Kennemur (S/PI)	Florida State University (FSU)	USA (FL)
Katye Fichter (S/PI)	Missouri State University	USA (MO)
Kendra Frederick (S/PI)	University of Texas, Southwestern	USA (TX)
Kevin Huang (S/PI)	University of South Carolina	USA (SC)
Kirill Kovnir (S)	University of California, Davis	USA (CA)
Kwang Hun Lim (S/PI)	East Carolina University	USA (NC)
Lawrence Alemany (S)	Rice University	USA (TX)
Lawrence Hornak (S)	University of Georgia	USA (GA)
Leah Casabianca (S/PI)	Clemson University	USA (SC)
Leonard Mueller (S/PI)	University of California, Riverside	USA (CA)
Likai Song (S/PI)	National High Magnetic Field Laboratory (NHMFL)	USA (FL)
Liliya Vugmeyster (S/PI)	University of Colorado, Denver	USA (CO)
Lucy Ngatia (S/PI)	Florida Agricultural and Mechanical University	USA (FL)
Malini Rajagopalan (S)	University of Texas Health Science Center at Tyler	USA (TX)
Mandip Sachdeva (S/PI)	Florida Agricultural and Mechanical University	USA (FL)
Mandip Singh (S)	Florida Agricultural and Mechanical University	USA (FL)
Mark Bird (S/PI)	National High Magnetic Field Laboratory (NHMFL)	USA (FL)
Masaya Takahashi (S)	University of Texas, Southwestern	USA (TX)
Michael Harrington (S/PI)	Huntington Medical Research Institutes	USA (CA)
Micheal Dunn (S)	University of California, Riverside	USA (CA)
Myriam Cotten (S/PI)	College of William and Mary	USA (VA)
Naresh Dalal (S/PI)	National High Magnetic Field Laboratory (NHMFL)	USA (FL)
Nicholas Zumbulyadis (S)	independent Scholar and Consultant	USA (NY)
Odemari Mbuya (S)	Florida Agricultural and Mechanical University	USA (FL)
Ozge Gunaydin-Sen (S/PI)	Lamar University	USA (TX)
Petr Gor'kov (S/PI)	National High Magnetic Field Laboratory (NHMFL)	USA (FL)
Pulickel Ajayan (S/PI)	Rice University	USA (TX)
Rafaela de Negri (S)	University of Miami	USA (FL)
Rajendra Arora (S)	Florida Agricultural and Mechanical University	USA (FL)
Ram Seshadri (S/PI)	University of California, Santa Barbara	USA (CA)
Ramesh Badisa (S/PI)	Florida Agricultural and Mechanical University	USA (FL)

# Appendix III – Geographic Distribution

Name	Organization	Country
Ravi Hadimani (S/PI)	Virginia Commonwealth University	USA (VA)
Renee Reams (S)	Florida Agricultural and Mechanical University	USA (FL)
Riqiang Fu (S/PI)	National High Magnetic Field Laboratory (NHMFL)	USA (FL)
Robert Griffin (S/PI)	Massachusetts Institute of Technology	USA (MA)
Robert Taylor (S)	Florida Agricultural and Mechanical University	USA (FL)
Sabyasachi Sen (S/PI)	University of California, Davis	USA (CA)
Samuel Grant (S/PI)	National High Magnetic Field Laboratory (NHMFL)	USA (FL)
Silvia Centeno (S)	The Metropolitan Museum of Art	USA (NY)
Smita Mohanty (S/PI)	Oklahoma State University	USA (OK)
Sophia Hayes (S/PI)	Washington University in St. Louis	USA (MO)
Sossina Haile (S/PI)	Northwestern University	USA (IL)
Stephen Hill (S/PI)	National High Magnetic Field Laboratory (NHMFL)	USA (FL)
Steve Blackband (S/PI)	University of Florida	USA (FL)
Sungsool Wi (S/PI)	National High Magnetic Field Laboratory (NHMFL)	USA (FL)
Sunil Krishnan (S)	University of Texas, MD Anderson Cancer Center	USA (TX)
Tatyana Polenova (S/PI)	University of Delaware	USA (DE)
Teng Ma (S)	Florida State University (FSU)	USA (FL)
Thomas Budinger (S/PI)	Lawrence Livermore National Laboratory	USA (CA)
Tim Cross (S/PI)	National High Magnetic Field Laboratory (NHMFL)	USA (FL)
Tobin Marks (S)	Northwestern University	USA (IL)
Tuo Wang (S/PI)	Louisiana State University	USA (LA)
Ulf Trociewitz (S/PI)	National High Magnetic Field Laboratory (NHMFL)	USA (FL)
Victor Schepkin (S/PI)	National High Magnetic Field Laboratory (NHMFL)	USA (FL)
Wenyu Huang (S/PI)	Iowa State University	USA (IA)
William Brey (S/PI)	National High Magnetic Field Laboratory (NHMFL)	USA (FL)
William Pomerantz (S/PI)	University of Minnesota, Twin Cities	USA (MN)
Yan Li (S/PI)	Florida State University (FSU)	USA (FL)
Yan-Yan Hu (S)	Florida State University (FSU)	USA (FL)
Youngjae Kim (S)	National High Magnetic Field Laboratory (NHMFL)	USA (FL)
Yuch Ping Hsieh (S)	Florida Agricultural and Mechanical University	USA (FL)
Zhehong Gan (S/PI)	National High Magnetic Field Laboratory (NHMFL)	USA (FL)
Zhenxing Feng (S)	Oregon State University	USA (OR)

## 1.6.2. Postdocs, USA – 32

Name	Organization	Country
Andrea Santamaria (P)	University of Miami	USA (FL)
Armando Jerome de Jesus (P)	University of Colorado, Boulder	USA (CO)
Cristian Escobar (P)	National High Magnetic Field Laboratory (NHMFL)	USA (FL)
Daphna Shimon (P)	Washington University in St. Louis	USA (MO)
Di Wu (P)	Florida State University (FSU)	USA (FL)
E. Vindana Ekanayake (P)	Sanford Burnham Prebys Medical Discovery Institute	USA (CA)
Elizabeth Mazzio (P)	Florida Agricultural and Mechanical University	USA (FL)
Ernesto Bosque (P)	National High Magnetic Field Laboratory (NHMFL)	USA (FL)
Gwladys Riviere (P)	University of Florida	USA (FL)

# Appendix III – Geographic Distribution

Name	Organization	Country
Jerris Hooker (P)	Florida Agricultural and Mechanical University	USA (FL)
Joana Paulino (P)	National High Magnetic Field Laboratory (NHMFL)	USA (FL)
Johannes McKay (P)	Keysight Technologies	USA (CA)
Ketan Patel (P)	Florida Agricultural and Mechanical University	USA (FL)
Maria Iglesias-Rodriguez (P/PI)	University of California, Santa Barbara	USA (CA)
Michael Colvin (P)	Massachusetts Institute of Technology	USA (MA)
Mingxue Tang (P)	Florida State University (FSU)	USA (FL)
Mohiuddin Ovee (P)	Oklahoma State University	USA (OK)
Nabanita Das (P)	University of Colorado, Boulder	USA (CO)
Paul Matson (P)	University of California, Santa Barbara	USA (CA)
Pieter Smith (P)	Florida State University (FSU)	USA (FL)
Rongfu Zhang (P)	National High Magnetic Field Laboratory (NHMFL)	USA (FL)
Suman Mazumder (P)	Oklahoma State University	USA (OK)
Tata Gopinath (P)	University of Minnesota, Twin Cities	USA (MN)
Thierry Dubroca (P)	National High Magnetic Field Laboratory (NHMFL)	USA (FL)
Valeria Di Tullio (P)	The Metropolitan Museum of Art	USA (NY)
Victoria Mooney (P)	Vertex Pharmaceuticals Inc.	USA (MA)
Xiaoling Wang (P)	National High Magnetic Field Laboratory (NHMFL)	USA (FL)
Xiaoyan Ding (P)	Pennsylvania State University	USA (PA)
Xue Kang (P)	Louisiana State University	USA (LA)
Xuyong Feng (P)	Florida State University (FSU)	USA (FL)
Yiling Xiao (P)	University of Texas Southwestern Medical Center	USA (TX)
Zheqin Yang (P)	Rensselaer Polytechnic Institute	USA (NY)

## 1.6.3. Students, USA – 55

Name	Organization	Country
Adewale Akinfaderin (G)	Florida State University (FSU)	USA (FL)
Alex Kirui (G)	Louisiana State University	USA (LA)
Alyssa Rose (G)	Florida State University (FSU)	USA (FL)
Andrew Harrison (G)	Virginia Commonwealth University	USA (VA)
Anvesh Kumar Reddy Dasari (G)	East Carolina University	USA (NC)
Archishman Ghosh (G)	Florida State University (FSU)	USA (FL)
Bethany Caulkins (G)	University of California, Riverside	USA (CA)
Bharat Chaudhary (G)	Oklahoma State University	USA (OK)
Brian Thomson (G)	Pennsylvania State University	USA (PA)
Courtney Dunn (U)	Oklahoma State University	USA (OK)
Daniel Davis (G)	National High Magnetic Field Laboratory (NHMFL)	USA (FL)
Daniel Mosiman (G)	University of Illinois at Urbana-Champaign	USA (IL)
David Hike (G)	Florida State University (FSU)	USA (FL)
Dillon Grice (U)	Florida State University (FSU)	USA (FL)
Eric Keeler (G)	Massachusetts Institute of Technology	USA (MA)
Erik Olson (U)	Florida State University (FSU)	USA (FL)
Evan Wenbo Zhao (G)	University of Florida	USA (FL)
Francisco Benavides Jaramillo (G)	University of Miami	USA (FL)

# Appendix III – Geographic Distribution

Name	Organization	Country
Frederick Bagdasarian (G)	Florida State University (FSU)	USA (FL)
Ghoncheh Amouzandeh (G)	Florida State University (FSU)	USA (FL)
Gmebisola Akinbi (G)	Florida Agricultural and Mechanical University	USA (FL)
Isaac Falconer (U)	University of Colorado, Denver	USA (CO)
Jackson Badger (G)	University of California, Davis	USA (CA)
Jamie Johnston (G)	Florida State University (FSU)	USA (FL)
Jin Zheng (G)	Florida State University (FSU)	USA (FL)
Joshua Taylor (U)	Florida State University (FSU)	USA (FL)
Kevin Affram (G)	Florida Agricultural and Mechanical University	USA (FL)
Leejoo Wi (G)	National High Magnetic Field Laboratory (NHMFL)	USA (FL)
Maxwell Marple (G)	University of California, Davis	USA (CA)
Michael Holliday (G)	University of Colorado, Denver	USA (CO)
Nastaren Abad (G)	Florida State University (FSU)	USA (FL)
Nathan Prisco (G)	University of California, Santa Barbara	USA (CA)
Peng Chen (G)	GE Healthcare	USA (SC)
Peter Ycas (G)	University of Minnesota, Twin Cities	USA (MN)
Po-Hsiu Chien (G)	Florida State University (FSU)	USA (FL)
Raghu Maligal-Ganesh (G)	Iowa State University	USA (IA)
Rahul Sangodkar (G)	University of California, Santa Barbara	USA (CA)
Robert Marti (G)	Washington University in St. Louis	USA (MO)
Sarah Nelson (G)	University of Minnesota, Twin Cities	USA (MN)
Scott Boebinger (U)	Florida State University (FSU)	USA (FL)
Shivakumar Hunagund (G)	Virginia Commonwealth University	USA (VA)
Sruthi Radhakrishnan (G)	Rice University	USA (TX)
Taylor Smith (G)	Florida Agricultural and Mechanical University	USA (FL)
Tommy Zhao (G)	University of Florida	USA (FL)
Victor Wong (U)	Florida State University (FSU)	USA (FL)
Whitney Costello (G)	University of Texas Southwestern Medical Center	USA (TX)
Xiang Li (G)	Florida State University (FSU)	USA (FL)
Xin Qiao (G)	University of Central Florida	USA (FL)
Xuegang Yuan (G)	Florida State University (FSU)	USA (FL)
Yimin Miao (G)	CUNY Graduate Center	USA (NY)
Yiseul Shin (G)	Florida State University (FSU)	USA (FL)
Yong Du (G)	University of Florida	USA (FL)
Yuanwei Yan (G)	Florida State University (FSU)	USA (FL)
Yvonne Afriyie (G)	Washington University in St. Louis	USA (MO)
Zachary Whittles (U)	University of California, Davis	USA (CA)

## 1.6.4. Technicians, USA – 8

Name	Organization	Country
Abdol Aziz Ould Ismail (T)	University of Pennsylvania	USA (PA)
Ashley Blue (T/PI)	National High Magnetic Field Laboratory (NHMFL)	USA (FL)
Bernie O'Hare (T)	Bruker Biospin	USA (MA)
Djanaan Nemours (T)	Florida Agricultural and Mechanical University	USA (FL)

# Appendix III – Geographic Distribution

Name	Organization	Country
Huajun Qin (T)	Florida State University (FSU)	USA (FL)
Jason Kitchen (T)	National High Magnetic Field Laboratory (NHMFL)	USA (FL)
Shannon Helsper (T)	National High Magnetic Field Laboratory (NHMFL)	USA (FL)
Steven Ranner (T)	National High Magnetic Field Laboratory (NHMFL)	USA (FL)

## 1.7. PF Facility

### 1.7.1. Senior Personnel, USA – 52

Name	Organization	Country
Angelo Mascarenhas (S/PI)	National Renewable Energy Laboratory	USA (CO)
Arkady Shehter (S/PI)	National High Magnetic Field Laboratory (NHMFL)	USA (FL)
Audrey Grockowiak (S/PI)	National High Magnetic Field Laboratory (NHMFL)	USA (FL)
Bellave Shivaram (S/PI)	University of Virginia	USA (VA)
Boris Maiorov (S/PI)	Los Alamos National Laboratory	USA (NM)
Brad Ramshaw (S/PI)	Cornell University	USA (NY)
Brian Maple (S/PI)	University of California, San Diego	USA (CA)
Charles Agosta (S/PI)	Clark University	USA (MA)
Charles Mielke (S/PI)	National High Magnetic Field Laboratory (NHMFL)	USA (NM)
Dagmar Weickert (S/PI)	National High Magnetic Field Laboratory (NHMFL)	USA (NM)
David Graf (S/PI)	National High Magnetic Field Laboratory (NHMFL)	USA (FL)
David Reagor (S/PI)	Los Alamos National Laboratory	USA (NM)
Doan Nguyen (S/PI)	National High Magnetic Field Laboratory (NHMFL)	USA (NM)
Eric Bauer (S/PI)	Los Alamos National Laboratory	USA (NM)
Fedor Balakirev (S/PI)	National High Magnetic Field Laboratory (NHMFL)	USA (NM)
Filip Ronning (S/PI)	Los Alamos National Laboratory	USA (NM)
Greg Boebinger (S/PI)	National High Magnetic Field Laboratory (NHMFL)	USA (FL)
Haidong Zhou (S/PI)	University of Tennessee, Knoxville	USA (TN)
Haiyan Wang (S/PI)	Texas A&M University	USA (TX)
Ian Fisher (S/PI)	Stanford University	USA (CA)
Istvan Robel (S)	Los Alamos National Laboratory	USA (NM)
James Analytis (S/PI)	University of California, Berkeley	USA (CA)
Jamie Manson (S/PI)	Eastern Washington University	USA (WA)
Janice Musfeldt (S/PI)	University of Tennessee, Knoxville	USA (TN)
Jason Jeffries (S)	Lawrence Livermore National Laboratory	USA (CA)
Jason Lashley (S/PI)	Los Alamos National Laboratory	USA (NM)
Jin Hu (S/PI)	Tulane University	USA (LA)
John Mitchell (S/PI)	Argonne National Laboratory	USA (IL)
John Schlueter (S/PI)	Argonne National Laboratory	USA (IL)
John Singleton (S/PI)	National High Magnetic Field Laboratory (NHMFL)	USA (NM)
Jonathan Betts (S/PI)	National High Magnetic Field Laboratory (NHMFL)	USA (NM)
Joseph Checkelsky (S/PI)	Massachusetts Institute of Technology	USA (MA)
Krzysztof Gofryk (S/PI)	Idaho National Laboratory	USA (ID)
Luis Balicas (S/PI)	National High Magnetic Field Laboratory (NHMFL)	USA (FL)
Marcelo Jaime (S/PI)	National High Magnetic Field Laboratory (NHMFL)	USA (NM)
N. Phuan Ong (S/PI)	Princeton University	USA (NJ)

# Appendix III – Geographic Distribution

Name	Organization	Country
Neil Harrison (S/PI)	National High Magnetic Field Laboratory (NHMFL)	USA (NM)
Nicholas Butch (S/PI)	National Institute of Standards and Technology	USA (MD)
Pei-Chun Ho (S/PI)	California State University, Fresno	USA (CA)
Qimiao Si (S)	Rice University	USA (TX)
Richard Greene (S/PI)	University of Maryland, College Park	USA (MD)
Richard Schaller (S/PI)	Argonne National Laboratory	USA (IL)
Ross McDonald (S/PI)	National High Magnetic Field Laboratory (NHMFL)	USA (NM)
Ryan Baumbach (S/PI)	National High Magnetic Field Laboratory (NHMFL)	USA (FL)
Sang Wook Cheong (S/PI)	Rutgers University, New Brunswick	USA (NJ)
Sara Haravifard (S/PI)	Duke University	USA (NC)
Scott Crooker (S/PI)	National High Magnetic Field Laboratory (NHMFL)	USA (NM)
Scott Riggs (S/PI)	National High Magnetic Field Laboratory (NHMFL)	USA (FL)
Stan Tozer (S/PI)	National High Magnetic Field Laboratory (NHMFL)	USA (FL)
Victor Klimov (S)	Los Alamos National Laboratory	USA (NM)
Vivien Zapf (S/PI)	National High Magnetic Field Laboratory (NHMFL)	USA (NM)
Zhiqiang Mao (S/PI)	Tulane University	USA (LA)

## 1.7.2. Postdocs, USA – 22

Name	Organization	Country
Andreas Stier (P/PI)	National High Magnetic Field Laboratory (NHMFL)	USA (NM)
Benjamin Diroll (P)	Argonne National Laboratory	USA (IL)
Jae Wook Kim (P)	Rutgers University, New Brunswick	USA (NJ)
Jose Galvis Echeverri (P)	National High Magnetic Field Laboratory (NHMFL)	USA (FL)
Joshua Higgins (P)	University of Maryland, College Park	USA (MD)
Keshav Shrestha (P)	Idaho National Laboratory	USA (ID)
Kirk Post (P)	National High Magnetic Field Laboratory (NHMFL)	USA (NM)
Laurel Stritzinger (P)	National High Magnetic Field Laboratory (NHMFL)	USA (NM)
Mateusz Goryca (P)	National High Magnetic Field Laboratory (NHMFL)	USA (NM)
Maxime Leroux (P)	Los Alamos National Laboratory	USA (NM)
Mun Chan (P/PI)	National High Magnetic Field Laboratory (NHMFL)	USA (NM)
Nicholas Breznay (P)	Lawrence Berkeley National Laboratory	USA (CA)
Paul Tobash (P)	National High Magnetic Field Laboratory (NHMFL)	USA (NM)
Paula Giraldo Gallo (P)	National High Magnetic Field Laboratory (NHMFL)	USA (FL)
Philip Walmsley (P)	Stanford University	USA (CA)
Shalinee Chikara (P/PI)	National High Magnetic Field Laboratory (NHMFL)	USA (NM)
Sheng Ran (P)	University of California, San Diego	USA (CA)
Takehito Suzuki (P)	Massachusetts Institute of Technology	USA (MA)
Tarapada Sarkar (P)	University of Maryland, College Park	USA (MD)
Trevor Keiber (P)	University of California, San Diego	USA (CA)
Xiixin Ding (P/PI)	National High Magnetic Field Laboratory (NHMFL)	USA (NM)
Zhenzhong Shi (P)	National High Magnetic Field Laboratory (NHMFL)	USA (FL)

## 1.7.3. Students, USA – 25

Name	Organization	Country
------	--------------	---------

# Appendix III – Geographic Distribution

Name	Organization	Country
Alexander Breindel (G)	University of California, San Diego	USA (CA)
Alexandra Brumberg (G)	Northwestern University	USA (IL)
Aravind Devarakonda (G)	Massachusetts Institute of Technology	USA (MA)
Brodie Popovic (G)	Duke University	USA (NC)
Chunlei Yue (G)	Tulane University	USA (LA)
Craig Topping (G)	National High Magnetic Field Laboratory (NHMFL)	USA (NM)
Ian Hayes (G)	University of California, Berkeley	USA (CA)
Jinyu Liu (G)	Tulane University	USA (LA)
Ken O'Neal (G)	University of Tennessee, Knoxville	USA (TN)
Kimberly Modic (G/PI)	National High Magnetic Field Laboratory (NHMFL)	USA (NM)
Linda Ye (G)	Massachusetts Institute of Technology	USA (MA)
Logan Bishop-Van Horn (U)	Clark University	USA (MA)
Maxwell Shapiro (G)	Stanford University	USA (CA)
Michael Yokosuk (G)	University of Tennessee, Knoxville	USA (TN)
Nathan Wilson (G)	University of Washington	USA (WA)
Nityan Nair (G)	University of California, Berkeley	USA (CA)
Ryan Rawl (G)	University of Tennessee, Knoxville	USA (TN)
Ryan Sinclair (G)	University of Tennessee, Knoxville	USA (TN)
Samantha Harvey (G)	Northwestern University	USA (IL)
Sihang Liang (G)	Princeton University	USA (NJ)
Tong Gao (G)	Princeton University	USA (NJ)
Wudi Wang (G)	Princeton University	USA (NJ)
Xiujun Iian (G)	National High Magnetic Field Laboratory (NHMFL)	USA (FL)
Xue Liu (G)	Tulane University	USA (LA)
Yanglin Zhu (G)	Tulane University	USA (LA)

## 1.7.4. Technicians, USA – 1

Name	Organization	Country
Kirstin Alberi (T/PI)	National Renewable Energy Laboratory	USA (CO)

# Appendix III – Geographic Distribution

## 2. International Distribution

### 2.1. AMRIS Facility – MagLab Funded

#### 2.1.1. a) Senior Personnel, NON-USA – 5

Name	Organization	Country
Arne Wittstock (S)	University Bremen	Germany
Ben Turner (S/PI)	Smithsonian Tropical Research Institute	Panama
Lilibeth Salvador (S/PI)	University of the Philippines	Philippines
Marcus Bäumer (S/PI)	University Bremen	Germany
Scott Prosser (S/PI)	University of Toronto	Canada

#### 2.1.2. a) Postdocs, NON-USA – 1

Name	Organization	Country
Samantha Grover (P)	La Trobe University	Australia

#### 2.1.3. a) Students, NON-USA – 2

Name	Organization	Country
Advait Hasabnis (G)	University of Toronto	Canada
Jeremiah Batucan (G)	University of the Philippines	Philippines

#### 2.1.4. a) Technicians, NON-USA - 0

### 2.1. AMRIS Facility – Independently Funded

#### 2.1.1. b) Senior Personnel, NON-USA – 1

Name	Organization	Country
Brian Hansen (S)	Aarhus University	Denmark

#### 2.1.2. b) Postdocs, NON-USA - 0

#### 2.1.3. b) Students, NON-USA - 0

#### 2.1.4. b) Technicians, NON-USA - 0

### 2.2. DC Field Facility

#### 2.2.1. Senior Personnel, NON-USA – 81

Name	Organization	Country
Alexander Tsirlin (S/PI)	National Institute of Chemical Physics and Biophysics	Estonia
Alexander Usoskin (S/PI)	Bruker HTS GmbH	Germany
Alois Loidl (S)	University of Augsburg	Germany
Amalia Coldea (S/PI)	University of Oxford	UK
Amir Abbas Haghighirad (S)	University of Oxford	UK
Andres Saul (S/PI)	Aix-Marseille University	France
Anna Palau (S)	Institute of Material Science of Barcelona	Spain
Bella Lake (S)	Helmholtz-Zentrum Berlin	Germany
Bernd Halbedel (S/PI)	Technische Universität Ilmenau	Germany
Bernhard Keimer (S)	Max Planck Institute	Germany
Bertram Batlogg (S/PI)	ETH Zürich	Switzerland
Cheol Eui Lee (S/PI)	Korea University	South Korea



# Appendix III – Geographic Distribution

Name	Organization	Country
Christian Rueegg (S/PI)	Paul Scherrer Institute	Switzerland
David Cardwell (S/PI)	University of Cambridge	UK
Faxian Xiu (S/PI)	Fudan University	China
Fernando Machado (S/PI)	Federal University of Pernambuco	Brazil
Frank Werfel (S)	Adelwitz Technologiezentrum GmbH	Germany
Gang Wu (S/PI)	Queen's University at Kingston	Canada
Gil Lonzarich (S/PI)	University of Cambridge	UK
Greg Scholes (S/PI)	Princeton University	Canada
Guillaume Gervais (S/PI)	McGill University	Canada
Hanna Dabkowska (S)	McMaster University	Canada
Hugen Yan (S/PI)	Fudan University	China
Irina Drichko (S/PI)	Ioffe Physical-Technical Institute of the Russian Academy of Sciences	Russia
Ivan Smirnov (S)	Ioffe Physical-Technical Institute of the Russian Academy of Sciences	Russia
Jens Haenisch (S/PI)	Karlsruhe Institute of Technology	Germany
Jianlin Luo (S)	Institute of Physics, Chinese Academy of Sciences	China
Jiun-Yun Li (S)	National Taiwan University	Taiwan
Joachim Deisenhofer (S)	University of Augsburg	Germany
John Durrell (S/PI)	University of Cambridge	UK
Jun Sung Kim (S/PI)	Pohang University of Science and Technology	South Korea
Karl Kraemer (S)	University of Bern	Switzerland
Kazuhito Uchida (S)	University of Tokyo	Japan
Kazumasa Iida (S/PI)	Nagoya University	Germany
Kee Hoon Kim (S/PI)	Seoul National University	South Korea
Keizo Murata (S/PI)	Osaka City University	Japan
Kwang Yong Choi (S/PI)	Chung Ang University	South Korea
Louis Taillefer (S/PI)	University of Sherbrooke	Canada
Malte Grosche (S/PI)	University of Cambridge	UK
Marcus Schmidt (S)	Max Planck Institute	Germany
Michael Baenitz (S/PI)	Max Planck Institute for Chemical Physics of Solids, Dresden, Germany	Germany
Nanlin Wang (S)	Peking University	China
Naoki Kikugawa (S/PI)	National Institute for Materials Science	Japan
Nicolas Doiron-Leyraud (S)	University of Sherbrooke	Canada
Ning Wang (S)	Hong Kong University of Science and Technology	China
Patricia Alireza (S/PI)	University of Cambridge	UK
Paul Goddard (S/PI)	University of Warwick	UK
Peter Christianen (S)	Radboud University Nijmegen	Netherlands
Philip Moll (S/PI)	ETH Zürich	Switzerland
Raivo Stern (S/PI)	National Institute of Chemical Physics and Biophysics	Estonia
Robert Schurko (S/PI)	University of Windsor	Canada
Sandor Bordacs (S)	Budapest University of Technology and Economics	Hungary
Satoru Nakatsuji (S/PI)	University of Tokyo	Japan
Sergei Zherlitsyn (S/PI)	Helmholtz-Zentrum Dresden-Rossendorf	Germany

# Appendix III – Geographic Distribution

Name	Organization	Country
Sergei Zvyagin (S/PI)	Helmholtz-Zentrum Dresden-Rossendorf	Germany
So Noguchi (S)	Hokkaido University	Japan
Suchitra Sebastian (S/PI)	University of Cambridge	UK
Sven Friedemann (S)	University of Bristol	UK
Tae Won Noh (S/PI)	Seoul National University	South Korea
Taichi Terashima (S/PI)	National Institute for Materials Science	Japan
Takao Ebihara (S/PI)	Shizuoka University	Japan
Takao Sasagawa (S)	Tokyo Institute of Technology	Japan
Teresa Puig (S/PI)	Institute of Material Science of Barcelona	Spain
Thomas Szkopek (S)	McGill University	Canada
Toomas Room (S/PI)	National Institute of Chemical Physics and Biophysics	Estonia
Toshihiro Taen (S)	University of Tokyo	Japan
Toshihito Osada (S/PI)	University of Tokyo	Japan
Toshikazu Nakamura (S)	Institute for Molecular Science	Japan
Vladimir Tsurkan (S)	Augsburg University	Germany
Woun Kang (S/PI)	Ewha Womans University	South Korea
Yejun Feng (S/PI)	Okinawa Institute of Science and Technology	Japan
Yongqing Li (S/PI)	Institute of Physics, Chinese Academy of Sciences	China
Yoram Dagan (S/PI)	Tel-Aviv University	Israel
Yoshimitsu Kohama (S/PI)	University of Tokyo	Japan
Young Jai Choi (S)	Yonsei University	South Korea
YounJung Jo (S/PI)	Kyungpook National University	South Korea
Yuanbo Zhang (S/PI)	Fudan University	China
Yuji Matsuda (S/PI)	Kyoto University	Japan
Yurii Skourski (S)	Helmholtz-Zentrum Dresden-Rossendorf	Germany
Zhiguo Chen (S/PI)	Institute of Physics, Chinese Academy of Sciences	China
Zhiqiang Li (S/PI)	SiChuan University	China

## 2.2.2. Postdocs, NON-USA – 24

Name	Organization	Country
Adrien Gourgout (P)	University of Sherbrooke	Canada
Anup Patel (P/PI)	University of Cambridge	UK
Bjoern Wehinger (P/PI)	University of Geneva, Switzerland	Switzerland
Bongju Kim (P)	Seoul National University	South Korea
Diana Quintero Castro (P)	Helmholtz-Zentrum Berlin	Germany
Dilip Bhoi (P)	Seoul National University	South Korea
Elizabeth Green (P/PI)	Helmholtz-Zentrum Dresden-Rossendorf	Germany
Hishiro Hirose (P)	National Institute for Materials Science	Japan
Jacob Dean (P)	University of Toronto	Canada
Jordan Baglo (P)	University of Cambridge	UK
Kent Shirer (P/PI)	Max Planck Institute for Chemical Physics of Solids	Germany
Kyu Won Lee (P)	Korea University	South Korea
Mariusz Kubus (P)	University of Bern	Denmark
Mark Ainslie (P)	University of Cambridge	UK

# Appendix III – Geographic Distribution

Name	Organization	Country
Mayukh Majumder (P)	Max Planck Institute	Germany
Pascal Reiss (P)	University of Oxford	UK
Susan Herringer (P)	University of Bern	Switzerland
Sven Badoux (P)	University of Sherbrooke	Canada
Toni Helm (P)	Max Planck Institute	Germany
Toshihiro Nomura (P)	Helmholtz-Zentrum Dresden-Rossendorf	Germany
Yasuyuki Shimura (P)	University of Tokyo	Japan
Yuriy Sakhratov (P/PI)	Kazan State Power Engineering University	Russia
Zhe Wang (P)	University of Augsburg	Germany
Zuocheng Zhang (P)	Fudan University	China

## 2.2.3. Students, NON-USA – 53

Name	Organization	Country
Aida Sanchez Ricol (U)	University of Cambridge	UK
Alexander Davies (G)	University of Cambridge	UK
Amirreza Ataei (G)	University of Sherbrooke	Canada
Anaëlle Legros (G)	University of Sherbrooke	Canada
Ce Huang (G)	Fudan University	China
ChangIl Kwon (G)	Pohang University of Science and Technology	South Korea
Chanhee Kim (G)	Seoul National University	South Korea
Chaoyu Song (G)	Fudan University	China
Cheng Zhang (G)	University of Washington	China
Clément Collignon (G)	University of Sherbrooke	Canada
Dániel Gergely Farkas (G)	Budapest University of Technology and Economics	Hungary
David Szaller (G)	Budapest University of Technology and Economics	Hungary
Do Wan Kim (G)	Korea University	South Korea
Eran Maniv (G)	Tel-Aviv University	Israel
Fangyuan Yang (G)	Fudan University	China
Ferran Valles (G)	Institute of Material Science of Barcelona	Spain
Francis Laliberte (G)	University of Sherbrooke	Canada
Gen Long (G)	Hong Kong University of Science and Technology	China
Greg Wallace (G)	University of Cambridge	UK
Guoyu Luo (G)	Sichuan University	China
Hoil Kim (G)	Pohang University of Science and Technology	South Korea
Hsu Liu (G)	University of Cambridge	UK
Hui Chang (G)	University of Cambridge	UK
Jan Srpčic (G)	University of Cambridge	UK
Jiangxiazhi Lin (G)	Hong Kong University of Science and Technology	China
Johan Viirok (G)	National Institute of Chemical Physics and Biophysics	Estonia
Jong Mok Ok (G)	Pohang University of Science and Technology	South Korea
Joosep Link (U)	National Institute of Chemical Physics and Biophysics	Estonia
Jordan Rush (G)	University of Cambridge	UK
Konstantin Semeniuk (G)	University of Cambridge	UK
Kysen Palmer (G)	University of Cambridge	UK

# Appendix III – Geographic Distribution

Name	Organization	Country
Liheng An (G)	Hong Kong University of Science and Technology	China
ManJin Eom (G)	Pohang University of Science and Technology	Korea
Mate Hartstein (G)	University of Cambridge	UK
Matei Petrescu (G)	McGill University	Canada
Maude Lizaire (G)	University of Sherbrooke	Canada
Myeong jun Oh (G)	Kyungpook National University	South Korea
Nicholas Hemsworth (G)	McGill University	Canada
Oleksii Vakaliuk (G)	Technische Universität Ilmenau	Germany
Péter Juhász (U)	University of Cambridge	UK
Po Zhang (G)	Peking University	China
Rico Schoenemann (G)	Helmholtz-Zentrum Dresden-Rossendorf	Germany
Shuaifei Guo (G)	Fudan University	China
Sofia Coronel (G)	University of Cambridge	UK
Sven Meyer (G)	Karlsruhe Institute of Technology	Germany
Tianyi Han (G)	Hong Kong University of Science and Technology	China
Woohyun Nam (G)	Seoul National University	Korea
Woojin Kim (G)	Seoul National University	South Korea
Xiang Yuan (G)	Fudan University	China
Xiaoxue Liu (G)	Peking University	China
Yanwen Liu (G)	Fudan University	China
Yeahan Sur (G)	Seoul National University	South Korea
Yu Hsu (G)	University of Cambridge	UK

## 2.2.4. Technicians, NON-USA - 1

Name	Organization	Country
Tony Dennis (T)	University of Cambridge	UK

## 2.3. EMR Facility

### 2.3.1. Senior Personnel, NON-USA – 26

Name	Organization	Country
Alberto Ghirri (S/PI)	CNR Institute Nanoscience	Italy
Enrique Colacio (S/PI)	University of Granada	Spain
Eugenio Coronado (S/PI)	University of Valencia	Spain
Francesc Lloret (S)	University of Valencia	Spain
Gael De Paepe (S)	The French Alternative Energies and Atomic Energy Commission	France
Joan Cano (S/PI)	University of Valencia	Spain
Julia Jezierska (S/PI)	University of Wroclaw	Poland
Lucio Frydman (S/PI)	Weizmann Institute of Science	Israel
Malgorzata Holynska (S/PI)	Philipps University Marburg	Germany
Marco Affronte (S/PI)	University of Modena and Reggio Emilia	Italy
Maria Korabik (S)	University of Wroclaw	Poland
Markus Enders (S/PI)	Heidelberg University	Germany
Miguel Julve (S)	University of Valencia	Spain

# Appendix III – Geographic Distribution

Name	Organization	Country
Olga Vassilyeva (S/PI)	Taras Shevchenko National University of Kyiv	Ukraine
Roman Boca (S/PI)	Slovak Technical University	Slovakia
Sabine Hediger (S)	The French Alternative Energies and Atomic Energy Commission	France
Sergei Zvyagin (S/PI)	Helmholtz-Zentrum Dresden-Rossendorf	Germany
Shimon Vega (S)	Weizmann Institute of Science	Israel
Stergios Piligkos (S/PI)	University of Copenhagen	Denmark
Svitlana Petrusenko (S)	Taras Shevchenko National University of Kyiv	Ukraine
Sylvain Bertaina (S/PI)	Institut Matériaux Microélectronique Nanosciences de Provence (IM2NP)	France
Vladimir Arion (S/PI)	University of Vienna	Austria
Wojciech Grochala (S/PI)	University of Warsaw	Poland
Zhenxing Wang (S/PI)	Huazhong University of Science and Technology	China
Zhongwen Ouyang (S)	Huazhong University of Science and Technology	China
Zoran Mazej (S)	Jozef Stefan Institute	Slovenia

## 2.3.2. Postdocs, NON-USA – 3

Name	Organization	Country
Emre Erdem (P)	University of Freiburg	Germany
Jurij Koruza (P/PI)	Technical University of Darmstadt	Germany
Maciej Witwicki (P/PI)	University of Wroclaw	Poland

## 2.3.3. Students, NON-USA – 7

Name	Organization	Country
Claudio Bonizzoni (G)	University of Pavia	Modena
Dejan Premuzic (G)	Philipps University Marburg	Germany
Jan Schultheiß (G)	Technical University of Darmstadt	Germany
Julia Vallejo (G)	University of Valencia	Spain
Katerina Kasyanova (G)	Taras Shevchenko National University of Kyiv	Ukraine
Likai Li (G)	Fudan University	China
Oleg Stetsiuk (U)	Taras Shevchenko National University of Kyiv	Ukraine

## 2.3.4. Technicians, NON-USA - 1

Name	Organization	Country
Clemens Pietzonka (T)	Philipps University Marburg	Germany

## 2.4. High B/T Facility

### 2.4.1. Senior Personnel, NON-USA – 4

Name	Organization	Country
Alix McCollam (S)	High Field Magnet Laboratory, Radboud University	Netherlands
Geetha Balakrishnan (S/PI)	University of Warwick	UK
Jurgen Smet (S/PI)	Max Planck Institute for Solid State Research,	Germany

# Appendix III – Geographic Distribution

Stephen Julian (S/PI)	Stuttgart, Germany University of Toronto	Canada
-----------------------	---	--------

## 2.4.2. Postdocs, NON-USA – 2

Name	Organization	Country
Joseph Falson (P)	Max Planck Institute for Solid State Research, Stuttgart, Germany	Germany
Monica Ciomaga Hatnean (P)	University of Warwick	UK

## 2.4.3. Students, NON-USA – 1

Name	Organization	Country
Daniela Tabrea (G)	Max Planck Institute for Solid State Research, Stuttgart, Germany	Germany

## 2.4.4. Technicians, NON-USA - 0

## 2.5. ICR Facility

### 2.5.1. Senior Personnel, NON-USA – 60

Name	Organization	Country
Alba Dieguez-Alonso (S)	Technical University of Berlin	Germany
Anatoly Prokushkin (S)	VN Sukachev Institute of Forest SB RAS	Russia
Andrea Gomez-Escudero (S/PI)	Universidad del Quindio	Colombia
Andreas Kappler (S/PI)	Eberhard Karls University of Tübingen	Germany
Andy Baker (S/PI)	University of New South Wales	Australia
Anna Silyakova (S)	University of Tromso, the Arctic University of Norway	Norway
Antonio Rodriguez-Fortea (S)	The Public University of Tarragona	Spain
Anu Krishnan (S)	Reliance Industries Limited	India
Benedicte Ferre (S)	University of Tromso, the Arctic University of Norway	Norway
Benny Chefetz (S/PI)	Hebrew University of Jerusalem	Israel
Brice Bouyssiére (S)	University of Pau and Pays de l'Adour	France
Carlos Afonso (S)	Normandy University	France
Caroline Mangote (S)	Total	France
Chandra Saravanan (S/PI)	Reliance Industries Limited	India
Christine Brown (S)	Shell Canada	Canada
Christophe Dicharry (S)	University of Pau and Pays de l'Adour	France
Christopher Ewels (S)	University of Nantes	France
Claudia Kammann (S)	Hochschule Geisenheim University	Germany
Claudia Mayrhofer (S)	FELMI-ZFE-Austrian Centre for Electron Microscopy	Austria
Cristian Blanco-Tirado (S)	Industrial University of Santander	Colombia
David Singh (S)	Reliance Industries Limited	India
Dena McMartin (S)	University of Regina	Canada
Eleanor Campbell (S/PI)	University of Edinburgh	UK
Eleanor Riches (S)	Waters Corporation	UK
Francois Guillemette (S/PI)	University of Quebec at Trois-Rivières	Canada
Friederike Grundger (S)	University of Tromso, the Arctic University of Norway	Norway

# Appendix III – Geographic Distribution

Name	Organization	Country
Gaëlle Jousset (S)	Total	France
Hans-Peter Schmidt (S)	Ithaka Institute	Switzerland
Jagdish Kedia (S)	Reliance Industries Limited	India
Johannes Harter (S)	Eberhard Karls University of Tübingen	Germany
John Headley (S/PI)	Environment and Climate Change Canada	Canada
John Maier (S/PI)	University of Basel	Switzerland
Jon Bailey (S)	Environment and Climate Change Canada	Canada
Josep Poblet (S/PI)	Rovira i Virgili University	Spain
Laura Abella (S)	The Public University of Tarragona	Spain
Leticia Ligiero (S)	University of Pau and Pays de l'Adour	France
Mandan Chidambaram (S)	Reliance Industries Limited	India
Marianny Combariza (S/PI)	Industrial University of Santander	Colombia
Martin Obst (S)	University of Bayreuth	Germany
Mayuresh Sahasrabudhe (S)	Reliance Industries Limited	India
Monique Haakensen (S)	Contango Strategies	Canada
Nicolas Passade-Boupat (S)	Total	France
Pascal Boeckx (S/PI)	Ghent University	Belgium
Patrick Bouriat (S)	Lacq Research and Studies Center	France
Paul del Giorgio (S/PI)	University of Quebec at Montreal	Canada
Paul Mann (S/PI)	Northumbria University	UK
Pellegrino Conte (S)	University of Palermo	Italy
Pierre Giusti (S/PI)	Total	France
Rachel Martz (S)	Contango Strategies	Canada
Ramachandra Chakravarthy (S)	Reliance Industries Limited	India
Richard LaBrie (S/PI)	University of Montreal	Canada
Sarasadat Taherymoosavi (S)	University of New South Wales	Australia
Silvia Orsetti (S)	Eberhard Karls University of Tübingen	Germany
Stephen Joseph (S)	The University of Newcastle	Australia
Takashi Uchida (S)	Toyo University, Kawagoe	Japan
Toru Maekawa (S/PI)	Toyo University, Kawagoe	Japan
Vanessa Friesen (S)	Contango Strategies	Canada
Yunping Xu (S/PI)	Shanghai Ocean University	China
Yury Tsybin (S/PI)	Spectroswiss Sarl	Switzerland
Yusuke Nishiyama (S)	JEOL, Ltd.	Japan

## 2.5.2. Postdocs, NON-USA – 5

Name	Organization	Country
Chaitanya Giri (P)	Tokyo Institute of Technology	Japan
Ewen Campbell (P)	University of Basel	Switzerland
Kerry Peru (P)	Environment and Climate Change Canada	Canada
Richard Racz (P)	Institute for Nuclear Research, Hungarian Academy of Sciences	Hungary
Sophie Crevecoeur (P)	University of Quebec at Montreal	Canada

# Appendix III – Geographic Distribution

## 2.5.3. Students, NON-USA – 11

Name	Organization	Country
Chukwuemeka Ajaero (G)	University of Regina	Canada
Edisson Subdiaga (G)	Eberhard Karls University of Tübingen	Germany
Liza McDonough (G)	University of New South Wales	Australia
Marijn Bauters (G)	Ghent University	Belgium
Mathilde Farenc (G)	University of Rouen	France
Minas Stefanou (G)	University of Edinburgh	Scotland
Muhammed Sert (G)	University of Tromso, the Arctic University of Norway	Norway
Nikolas Hagemann (G)	Eberhard Karls University of Tübingen	Germany
Ruben del Campo (G)	Universidad de Navarra / University of Navarra	Spain
Sara Gutiérrez Sama (G)	University of Pau and Pays de l'Adour	France
Yuge Bai (G)	Eberhard Karls University of Tübingen	Germany

## 2.5.4. Technicians, NON-USA - 0

## 2.6. NMR Facility

### 2.6.1. Senior Personnel, NON-USA – 48

Name	Organization	Country
Adrian Griffin (S)	Oxford NMR Ltd	UK
Andre Kuehne (S)	MRI.TOOLS GmbH	Germany
Andreas Pohlmann (S)	Max Delbrück Center for Molecular Medicine in the Helmholtz Association	Germany
Arthur Schwilch (S)	Bruker BioSpin AG	Switzerland
Brian Hansen (S)	Aarhus University	Denmark
Chang Hyun Lee (S/PI)	Dankook University	South Korea
Christian Schuch (S)	NUKEM Isotopes Imaging GmbH	Germany
Conggang Li (S/PI)	Wuhan Institute of Physics & Mathematics, Chinese Academy of Sciences	China
Duk-Young Jung (S)	Sungkyunkwan University	South Korea
Elizabeth Bradbury (S)	King's College London	UK
Eric Gottwald (S/PI)	Karlsruhe Institute of Technology	Germany
Gael De Paepe (S)	The French Alternative Energies and Atomic Energy Commission	France
Gang Wu (S/PI)	Queen's University at Kingston	Canada
Guilherme Oliveira (S)	Federal University of Rio de Janeiro	Brazil
Hans Jakobsen (S/PI)	Aarhus University	Denmark
Helmar Waiczies (S)	MRI.TOOLS GmbH	Germany
Henrik Bildsoe (S)	Aarhus University	Denmark
Jason Millward (S)	Max Delbrueck Center for Molecular Medicine	Germany
Joost Verhaagen (S)	Free University of Amsterdam	Netherlands
Jun Xu (S/PI)	Wuhan Institute of Physics & Mathematics, Chinese Academy of Sciences	China
Lia Addadi (S)	Weizmann Institute of Science	Israel
Lothar Schad (S/PI)	Heidelberg University	Germany
Lucio Frydman (S/PI)	Weizmann Institute of Science	Israel



# Appendix III – Geographic Distribution

Name	Organization	Country
Ludger Starke (S)	Max Delbrueck Center for Molecular Medicine	Germany
Michael Brorson (S)	Haldor Topsoe	Denmark
Michael Kievel (S)	NUKEM Isotopes Imaging GmbH	Germany
Michai Neeman (S)	Weizmann Institute of Science	Israel
Nicolas Freytag (S)	Bruker Biospin	Switzerland
Oc Hee Han (S/PI)	Korea Basic Science Institute	South Korea
Paula Delgado (S)	Max Delbrueck Center for Molecular Medicine	Germany
Pietro Lendi (S)	Bruker BioSpin AG	Switzerland
Rivera de la Rosa (S)	Autonomous University of Nuevo León	Mexico
Rolf Hensel (S)	Bruker Biospin AG	Switzerland
Sabine Hediger (S)	The French Alternative Energies and Atomic Energy Commission	France
Shimon Vega (S)	Weizmann Institute of Science	Israel
Sonia Waiczies (S/PI)	Max Delbrück Center for Molecular Medicine in the Helmholtz Association	Germany
Steve Weiner (S)	Weizmann Institute of Science	Israel
Svend Knak Jensen (S)	Aarhus University	Denmark
Thoralf Niendorf (S)	Max Delbrück Center for Molecular Medicine in the Helmholtz Association	Germany
Tilo Glaeser (S)	NUKEM Isotopes Imaging GmbH	Germany
Vladimir Michaelis (S)	University of Alberta	Canada
Wei David Wang (S)	Lanzhou University	China
Wei Wang (S/PI)	Lanzhou University	China
Xinhua Peng (S)	University of Science and Technology of China	China
Yong Yang (S/PI)	Xiamen University	China
Yuqing Huang (S)	Xiamen University	China
Yuval Golan (S)	Ben Gurion University of the Negev	Israel
Zhong Chen (S/PI)	Xiamen University	China

## 2.6.2. Postdocs, NON-USA – 6

Name	Organization	Country
Andreas Neubauer (P/PI)	Heidelberg University	Germany
Avigdor Leftin (P/PI)	Weizmann Institute of Science	Israel
Jun Li (P)	Beijing Computational Science Research Center	China
Stefan Markovic (P)	Weizmann Institute of Science	Israel
Tangi Roussel (P)	Alternative Energies and Atomic Energy Commission	France
Zhiyong Zhang (P)	Weizmann Institute of Science	Israel

## 2.6.3. Students, NON-USA – 9

Name	Organization	Country
Betty Lin (G)	Queen's University at Kingston	Canada
Christian Prinz (G)	Max Delbrueck Center for Molecular Medicine	Germany
Gabriela Campos de Araujo (G)	UNESP	Brazil
Guiming Zhong (G)	Xiamen University	China

# Appendix III – Geographic Distribution

Name	Organization	Country
Jiahui Shen (G)	Queen's University at Kingston	Canada
Jiangyu Cui (G)	University of Science and Technology of China	China
Kaiyu Wang (G)	Xiamen University	China
Mayra Marques (G)	Federal University of Rio de Janeiro	Brazil
Se Youn Pyo (G)	Dankook University	South Korea

## 2.6.4. Technicians, NON-USA - 2

Name	Organization	Country
Qiang Wang (T)	Wuhan Institute of Physics & Mathematics, Chinese Academy of Sciences	China
Vijay Ramaswamy (T)	Bruker Biospin	Switzerland

## 2.7. PF Facility

### 2.7.1. Senior Personnel, NON-USA – 20

Name	Organization	Country
Andrew Wildes (S/PI)	Institut Laue-Langevin	France
Antonio Vecchione (S/PI)	CNR Institute SPIN	Italy
Bertram Batlogg (S/PI)	ETH Zürich	Switzerland
Geetha Balakrishnan (S/PI)	University of Warwick	UK
Grace Morgan (S/PI)	University College Dublin	Ireland
Henrik Ronnow (S)	Ecole Polytechnique Federale de Lausanne	Switzerland
Heon-Jung Kim (S)	Daegu University	South Korea
Jeehoon Kim (S/PI)	Pohang University of Science and Technology	South Korea
Ki-Seok Kim (S)	Pohang University of Science and Technology	South Korea
Manuel Sanchez-Anduljar (S)	University of Coruna	Spain
Maria Señaris-Rodriguez (S/PI)	University of Coruna	Spain
Masashi Miura (S/PI)	Seikei University	Japan
Pablo Esquinazi (S/PI)	Leipzig University	Germany
Paul Goddard (S/PI)	University of Warwick	UK
Philip Moll (S/PI)	ETH Zürich	Switzerland
Silke Buehler-Paschen (S/PI)	Technical University of Wien	Austria
Stefan Sullow (S/PI)	Technical University of Braunschweig	Germany
Suchitra Sebastian (S/PI)	University of Cambridge	UK
Yisheng Chai (S/PI)	Chongqing University	China
Young Sun (S/PI)	Institute of Physics, Chinese Academy of Sciences	China

### 2.7.2. Postdocs, NON-USA – 6

Name	Organization	Country
Diego Zocco (P)	Technical University of Wien	Austria
Irina Kuehne (P)	University College Dublin	Ireland
José Barzola-Quiquia (P)	Leipzig University	Germany
Kathrin Gotze (P)	University of Warwick	UK
Kent Shirer (P/PI)	Max Planck Institute for Chemical Physics of Solids	Germany
Toni Helm (P)	Max Planck Institute	Germany

# Appendix III – Geographic Distribution

## 2.7.3. Students, NON-USA – 11

<b>Name</b>	<b>Organization</b>	<b>Country</b>
Christian Precker (G)	Leipzig University	Germany
Diane Lançon (G)	Institut Laue-Langevin	France
Dongwoo Shin (G)	Pohang University of Science and Technology	South Korea
Geunyoung Kim (G)	Pohang University of Science and Technology	South Korea
Hsu Liu (G)	University of Cambridge	UK
Jamie Brambleby (G)	University of Warwick	UK
Jinho Yang (G)	Pohang University of Science and Technology	Korea
Juan Bermúdez-García (G)	University of Coruna	Spain
Maja Bachmann (G)	Max Planck Institute for Chemical Physics of Solids	Germany
Priscilla Rosa (G)	University Estadual de Campinas	Brazil
Vibe Jakobsen (G)	University College Dublin	Ireland

## 2.7.4. Technicians, NON-USA - 0



# Appendix IV – Personnel



# Appendix IV – Personnel

## NSF Category: Senior Personnel – Total 220

Name	Position Title
<b>100 - Management and Administration</b>	
Greene, Laura	Chief Scientist
Rea, Clyde	Assistant Director, Business & Financial / Auxiliary Services
<b>300 - DC Instrumentation</b>	
Hannahs, Scott	Research Faculty III
<b>400 - Magnet Science &amp; Technology</b>	
Bai, Hongyu	Research Faculty II
Bird, Mark	Research Faculty III, Director, Magnet Science & Technology
Crooks, Roy	Visiting Assistant Scholar / Scientist
Dixon, Iain	Research Faculty III
Erickson, Greg	Biology Professor
Gavrilin, Andrey	Research Faculty III
Guo, Wei	Professor
Han, Ke	Research Faculty III
Kalu, Peter	Professor
Lu, Jun	Research Faculty II
Markiewicz, William	Research Assistant
Marshall, William	Sr Research Associate
Painter, Thomas	Sr Research Associate
Toth, Jack	Research Faculty III
Van Sciver, Steven	Professor
Walsh, Robert	Sr Research Associate
Weijers, Hubertus	Research Faculty III
Xin, Yan	Research Faculty III
Zavion, Sheryl	Sr Research Associate (MS&T Operations Manager)
Zeller, Al	Visiting Scientist/Researcher
<b>500 - Condensed Matter Science</b>	
Albrecht-Schmitt, Thomas	Professor
Andrei, Petru	Associate Professor
Baek, Hongwoo	Research Faculty I
Balicas, Luis	Research Faculty III
Baumbach, Ryan	Research Faculty I
Beekman, Christianne	Assistant Professor
Bonesteel, Nicholas	Professor
Cao, Jianming	Professor
Chiorescu, Irinel	Professor
Choi, Eun Sang	Research Faculty III
Coniglio, William	Research Faculty I
Dalal, Naresh	Professor
Dobrosavljevic, Vladimir	Professor
Dubroca, Thierry	Visiting Research Faculty
Engel, Lloyd	Research Faculty III
Fajer, Piotr	Professor
Gao, Hanwei	Assistant Professor
Graf, David	Research Faculty II

# Appendix IV – Personnel

Name	Position Title
Grockowiak, Audrey	Visiting Research Faculty I
Hill, Stephen	Professor/EMR Director
Huang, Chen	Assistant Professor
Jaroszynski, Jan	Research Faculty II
Kennemur, Justin	Assistant Professor
Kovalev, Alexey	Assistant In Research
Krzystek, Jerzy	Research Faculty III
Ma, Biwu	Associate Professor
Manousakis, Efstratios	Professor
McGill, Stephen	Research Faculty II
Mendoza-Cortes, Jose	Assistant Professor
Mondal, Arindam	Visiting Scientist/Researcher
Murphy, Timothy	Director, DC Field Facility
Oates, William	Assistant Professor
Ozarowski, Andrzej	Research Faculty II
Ozerov, Mykhaylo	Research Faculty I
Park, Jin Gyu	Professor
Park, Ju-Hyun	Research Faculty II
Park, Wan Kyu	Research Faculty II
Popovic, Dragana	Research Faculty III
Pradhan, Nihar	Adjunct Research Faculty I
Ramakrishnan, Subramanian	Associate Professor
Reyes, Arneil	Research Faculty III
Rikvold, Per	Professor
Schlottmann, Pedro	Professor
Schlueter, John	Visiting Scientist/Researcher
Schneemeyer, Lynn	Visiting Associate in
Shatruk, Mykhailo	Assistant Professor
Shehter, Arkady	Research Faculty I
Siegrist, Theo	Professor
Smirnov, Dmitry	Research Faculty III
Smith, Julia	Research Faculty I
Song, Likai	Research Faculty I
Suslov, Alexey	Research Faculty III
Thirunavukkuarasu, Komalavalli	Assistant Professor at FAMU
Tozer, Stanley	Research Faculty III
Vafek, Oskar	Associate Professor
van Tol, Johan	Research Faculty III
Whalen, Jeffrey	Research Faculty I
Yang, Kun	Professor
Yu, Zhibin	Assistant Professor
Zhang, Mei	Associate Professor
Zhou, Haidong	Adjunct Assistant Scholar/Scientist
<b>600 - LANL</b>	
Balakirev, Fedor	Staff Member

# Appendix IV – Personnel

Name	Position Title
Betts, Jonathan	Director of Operations
Chan, Mun Keat	Staff Member
Crooker, Scott	Staff Member
Harrison, Neil	Staff Member
Hinrichs, Mark	Electrical Engineer
Jaime, Marcelo	Staff Member
Maiorov, Boris	Staff Member
McDonald, Ross	Deputy Director, Pulsed Field Facility
Mielke, Charles	Director, Pulsed Field Facility at LANL and Program Director
Migliori, Albert	Staff Member and LANL Fellow
Nguyen, Doan	Director of Pulsed Field Facility Magnet Science and Technology
Rickel, Dwight	Emeritus Staff Member
Singleton, John	Staff Member and LANL Fellow
Zapf, Vivien	Staff Member
<b>700 - CIMAR</b>	
Alamo, Rufina	Professor
Anderson, Lissa	Research Faculty I
Arora, Rajendra	Professor
Badisa, Ramesh	Assistant Professor
Blakney, Gregory	Research Faculty II
Brey, William	Research Faculty III
Chen, Huan	Visiting Research Faculty I
Corilo, Yuri	Research Faculty I, Director of Informatics Research & Modeling
Cross, Timothy	Professor
Dunk, Paul	Visiting Research Faculty I
Frydman, Lucio	Chief Scientist for Chemistry & Biology
Fu, Riqiang	Research Faculty III
Gan, Zhehong	Research Faculty III
Gor'kov, Peter	Sr Research Associate
Grant, Samuel	Associate Professor
Hallinan, Daniel	Assistant Professor
Hendrickson, Christopher	Research Faculty III/Director of ICR Program
Hu, Yan-Yan	Assistant Professor
Hung, Ivan	Associate in Research
Kim, Jeong-su	Associate Professor
Lalli, Priscila	Visiting Research Faculty I
Levenson, Cathy	Professor
Litvak, Ilya	Assistant In Research
Lu, Jie	Associate in Research
Marshall, Alan	Professor, Chief Scientist for Ion Cyclotron Resonance (ICR) and Robert O. Lawton Distinguished Professor of Chemistry
McKenna, Amy	Research Faculty II
Mentink-Vigier, Frederic	Visiting Research Faculty I
Mohammadigoushki, Hadi	Assistant Professor
Qin, Huajun	Associate in Research

# Appendix IV – Personnel

Name	Position Title
Rodgers, Ryan	Research Faculty III, Research Faculty III
Rosenberg, Jens	Research Faculty I
Rowland, Steven	Visiting Research Faculty I
Schepkin, Victor	Research Faculty II
Smith, Donald	Research Faculty I
Weisbrod, Chad	Research Faculty I
Wi, Sungsool	Research Faculty II
Yi, Myunggi	Visiting Scientist/Researcher
Zhou, Huan-Xiang	Professor
<b>800 - UF</b>	
Angerhofer, Alexander	Professor, Chemistry
Biswas, Amlan	Associate Professor of Physics
Blackband, Stephen	Professor, Neuroscience
Bowers, Clifford	Professor
Butcher, Rebecca	Assistant Professor
Cheng, Hai Ping	Professor of Physics
Christou, George	Drago Chair and Distinguished Professor
Ding, Yousong	Assistant Professor
Fanucci, Gail	Professor
Febo, Marcelo	Assistant Professor
Fitzsimmons, Jeffrey	Professor, Radiology
Forder, John	Associate Professor of Radiology
Hagen, Stephen	Professor & Associate Chair of Physics
Hahn, Daniel	Associate Professor
Hamlin, James	Assistant Professor
Hebard, Arthur	Distinguished Professor of Physics
Hershfield, Selman	Professor
Hirschfeld, Peter	Distinguished Professor
Huan, Chao	Assistant Scholar / Scientist
Ihas, Gary	Emeritus Professor
Ingersent, Kevin	Chair of UF Physics Department & Professor, Chair, UF Physics Dept.
Kumar, Pradeep	Emeritus Professor
Lai, Song	Professor of Radiation Oncology and Neurology, Director, CTSI Human Imaging Core McKnight Brain Institute, Director, CTSI Human Imaging Core McKnight Brain Institute
Lee, Yoonseok	Professor
Long, Joanna	Associate Professor, NHMFL Director of AMRIS, NHMFL Director of AMRIS
Luesch, Hendrik	Professor and Chair, Department of Medicinal Chemistry, Professor
Mareci, Thomas	Professor
Maslov, Dmitrii	Professor
Masuhara, Naoto	Senior Engineer, Microkelvin Laboratory
Meisel, Mark	Professor of Physics
Merritt, Matthew	Associate Professor
Murray, Leslie	Assistant Professor
Muttalib, Khandker	Professor



# Appendix IV – Personnel

Name	Position Title
Rinzler, Andrew	Professor
Stanton, Christopher	Professor
Stewart, Gregory	Professor
Sullivan, Neil	Professor, Director of High B/T Facility, Director of High B/T Facility
Takano, Yasumasa	Professor
Talham, Daniel	Professor
Tanner, David	Distinguished Professor of Physics
Vaillancourt, David	Professor
Vandenborne, Krista	Professor
Vasenkov, Sergey	Associate Professor
Walter, Glenn	Associate Professor
Xia, Jian-Sheng	Scholar / Scientist
Zeng, Huadong	Specialist, Animal MRI/S Applications
<b>1100 - ASC</b>	
Abraimov, Dmytro	Research Faculty II
Bosque, Ernesto	Research Faculty I
Cheggour, Najib	Research Faculty II
Cooley, Lance	Professor
Griffin, Van	Senior Research Associate
Hahn, Seungyong	Professor
Hellstrom, Eric	Professor
Jiang, Jianyi	Research Faculty II
Kametani, Fumitake	Assistant Professor
Kim, Youngjae	Research Faculty 1
Larbalestier, David	Chief Materials Scientist, Director, Applied Superconductivity Center
Lee, Peter	Research Faculty III
Pamidi, Sastry	Associate Professor, Electrical & Computing Engineering; Associate Director, Center for Advanced Power Systems
Starch, William	Senior Research Associate
Tarantini, Chiara	Research Faculty II
Trociewitz, Ulf	Research Faculty III
<b>1200 - Director's Office</b>	
Boebinger, Gregory	Director/Professor, Professor of Physics
Gray, Laymon	Asst Dir Safety & Security
Howell, Matt	Fire Systems Technician
Hughes, Roxanne	Research Faculty II, Director, Center for Integrating Research and Learning
Ivey, Gail	Fire Code Inspector
Marconnet, Jason	Industrial Hygienist
Palm, Eric	Deputy Lab Director
Roberts, Kristin	Director of Public Affairs
Weickert, Dagmar	Visiting Research Faculty I
Woods, Marvin	Assistant Director of Research Support
<b>1300 - Geochemistry</b>	
Chanton, Jeff	Professor
Froelich, Philip	Scientist

# Appendix IV – Personnel

Name	Position Title
Humayun, Munir	Professor
Landing, William	Professor
Morton, Peter	Visiting Assistant in
Odom, Leroy	Professor
Owens, Jeremy	Assistant Professor
Salters, Vincent	Professor and Director, Geochemistry Program
Spencer, Robert	Assistant Professor
Wang, Yang	Professor
Young, Seth	Assistant Professor

## NSF Category: Postdoc - Total 56

Name	Position Title
<b>400 - Magnet Science &amp; Technology</b>	
Bao, Shiran	Postdoctoral Associate
Li, Huigai	Visiting Assistant Scholar / Scientist
Niu, Rongmei	Postdoctoral Associate
Shafieizadeh, Zahra	Graduate Research Assistant
<b>500 - Condensed Matter Science</b>	
Anand, Naweem	Postdoctoral Associate
Benjamin, Shermane	Postdoctoral Associate
Bevara, Vamsci	Postdoctoral Associate
Chakraborty, Shantanu	Postdoctoral Associate
Chen, Li	Postdoctoral Associate
Curtis, Jeremy	Postdoctoral Associate
Huang, Kevin	Postdoctoral Associate
Kang, Jian	Postdoctoral Associate
Lanata, Nicola	Postdoctoral Associate
Li, JunQiang	Postdoctoral Associate
Li, Songci	Postdoctoral Associate
Martens, Mathew	Postdoctoral Associate
Mozaffari, Shirin	Postdoctoral Associate
Nehrkorn, Joscha	Postdoctoral Associate
Pakhira, Srimanta	Postdoctoral Associate
Quito, Victor	Postdoctoral Associate
Rebar, Drew	Postdoctoral Associate
Schoenemann, Rico Uwe	Postdoctoral Associate
Stoian, Sebastian	Postdoctoral Associate
Sur, Shouvik	Postdoctoral Associate
Tennakoon, Sumudu	Postdoctoral Associate
Terzic, Jasminka	Postdoctoral Associate
Wei, Kaya	Postdoctoral Associate
<b>600 - LANL</b>	
Balk, Andrew	Postdoctoral Associate
Dey, Prasenjit	Postdoctoral Associate
Ding, Xiabin	Postdoctoral Associate

# Appendix IV – Personnel

Name	Position Title
Stier, Andreas	Postdoc Research Associate
Stritzinger, Laurel	Postdoctoral Associate
<b>700 - CIMAR</b>	
Chacon Patino, Martha	Postdoctoral Associate
DeHart, Caroline	Postdoctoral Associate
Escobar Bravo, Cristian	Postdoctoral Associate
Hooker, Jerris	Postdoctoral Associate
Leng, Xiaoling	Postdoctoral Associate
Murray, Dylan	Postdoctoral Associate
Paulino, Joana	Postdoctoral Associate
Smith, Pieter	Postdoctoral Associate
Smrt, Sean	Postdoctoral Associate
Tang, Mingxue	Postdoctoral Associate
Wang, Xiaoling	Postdoctoral Associate
Zhang, Rongfu	Postdoctoral Associate
<b>800 - UF</b>	
Riviere, Gwladys	Postdoctoral Associate
Woods, Andrew	Postdoctoral Associate
<b>1100 - ASC</b>	
Balachandran, Shreyas	Postdoctoral Associate
Bovone, Gianmarco	Postdoctoral Associate
Constantinescu, Anca-Monia	Postdoctoral Associate
Kim, Kwang Lok	Postdoctoral Associate
Kim, Kwangmin	Postdoctoral Associate
<b>1300 - Geochemistry</b>	
Kellerman, Anne	Postdoctoral Associate
Shelley, Rachel	Postdoctoral Associate
Them, Theodore	Postdoctoral Associate
Wu, Fei	Postdoctoral Associate
Yang, Shuying	Postdoctoral Associate
<b>NSF Category: Other Professional – Total 93</b>	
Name	Position Title
<b>100 - Management and Administration</b>	
Barron, John	Maintenance Mechanic
Berhalter, James	Technology Specialist
Brooks, Erica	Technology Specialist
Clark, Eric	Assistant Director, Technology Services
Cobb, Damaris	Program Coordinator, Purchasing
Hunter, Tra	Plant Engineer
Jensen, Peter	Network Administrator
Kynoch, John	Assistant Director
McCrary, Marcia	Budget Analyst
McEachern, Judy	Assistant Director, Business Systems
Mook, Bradley	Budget Analyst

# Appendix IV – Personnel

Name	Position Title
Queale, Abby	Patent Attorney
Schwerin, John	Technology Specialist
Wackes, Christina	Administrative Specialist
Wood, Marshall	Facilities Electrical Supervisor
<b>300 - DC Instrumentation</b>	
Billings, Jonathan	Scientific Research Specialist
Boenig, Heinrich	Engineer
Dalton, Bryon	Scientific Research Specialist
Jones, Glover	Scientific Research Specialist
Maier, Scott	Scientific Research Specialist
Powell, James	Research Engineer
Rubes, Edward	Scientific Research Specialist
Semenov, Dmitry	Scientific Research Specialist
Stiers, Eric	Research Engineer
Vanderlaan, Mark	Research Engineer, Cryogenic Operations
Williams, Vaughan	Research Engineer
<b>400 - Magnet Science &amp; Technology</b>	
Adkins, Todd	Research Engineer
Bole, Scott	Research Engineer
Cantrell, Kurtis	Research Engineer
Geohagan, Doris	Accounting Specialist
Goddard, Robert	Scientific Research Specialist
Gundlach, Scott	Research Engineer
Jarvis, Brent	Research Engineer
Lucia, Joseph	Technical/Research Designer
Marks, Emsley	Research Engineer
Mellow, Amy	Administrative Specialist
Miller, George	Research Engineer
Noyes, Patrick	Sr Research Associate
O'Reilly, James	Research Engineer
Richardson, Donald	Research Engineer
Sheppard, William	Research Engineer
Stanton, Robert	Research Engineer
Su, Yi-Feng	Research Specialist
Toplosky, Vince	Scientific Research Specialist
Viouchkov, Youri	Research Engineer
Voran, Adam	Research Engineer
White, James	Research Engineer
<b>500 - Condensed Matter Science</b>	
Dong, Lianyang	Research Assistant
Javed, Arshad	Grants Compliance Analyst
Luallen, Renee	Program Coordinator
Trociewitz, Bianca	Research Engineer
<b>700 - CIMAR</b>	
Bickett, Karol	Senior Administrative Specialist

# Appendix IV – Personnel

Name	Position Title
Hodges, Kurt	Coordinator, Animal Welfare Compliance
Kitchen, Jason	NMR Engineer
McIntosh, Daniel	Scientific Research Specialist
Quinn, John	Research Engineer
Ranner, Steven	Research Engineer
Wright, Anna	Research Assistant
<b>800 - UF</b>	
Elumalai, Malathy	RF Engineer
Jenkins, Kelly	RF Coil Engineer
Nicholson, Tammy	Certified Radiology Technology Mgr. (3T Imaging Applications)
Rocca, James	Senior Chemist & NMR Applications Specialist
<b>1100 - ASC</b>	
Hancock, Felicia	Administrative Specialist
Linville, Connie	Administrative Specialist
Polyanskii, Anatolii	Magneto Optical Research Specialist
<b>1200 - Director's Office</b>	
Arline, Benjamin	Asst Chem Safety Officer
Bilenky, Stephen	Videographer
Brown, Alfie	Industrial Safety & Health Eng
Coyne, Kristen	Program Manager
Davis, Andrew	Asst Chemical Safety Officer
Diaz-Jimenez, Carlos	Research Engineer (Safety Engineer)
Furrow, Lindsey	Assistant Chemical Safety Officer
Gray, Ashley	Asst Biological Safety Officer
Herrera-Gray, Glenda	Occ Health & Safety Specialist
Jacobson, Thomas	Director, EH&S FSU
Johnson, Jason	Radiation Safety Officer
Klawinski, Mark	Industrial Hygienist
LaBelle, Benjamin	Asst Laboratory Safety Officer
Le, Richard	Biological Safety Officer
McNiel, Caroline	Media Specialist
Murray, Renee	Chemical Safety Officer
Plansoen, Lou	Occ Health & Safety Specialist
Richerson, Lezlee	Administrative Specialist
Roberson, Bettina	Assistant Director, Administrative Services, Human Resources
Roberts, Kari	Program Coordinator
Rodman, Christopher	Industrial Safety & Health Eng.
Sanchez, Jose	Program Coordinator
Tabtintong, Nilubon	Media Specialist
Toth, Anke	Program Manager
Villa, Carlos	Outreach Coordinator
<b>1300 - Geochemistry</b>	
Sachi-Kocher, Afi	Scientific Research Specialist
Stukel, Michael	Assistant Professor
White, Gary	Scientific Research Specialist

# Appendix IV – Personnel

## NSF Category: Graduate Student - Total 162

Name	Position Title
<b>100 - Management and Administration</b>	
Zhang, Shengzhi	Graduate Research Assistant
<b>400 - Magnet Science &amp; Technology</b>	
An, Bailing	Visiting Scientist/Researcher
Garceau, Nathaniel	Graduate Research Assistant
Gordon, Renee	Research Assistant
Ijagbemi, Kikelomo	Research Assistant
Mastracci, Brian	Graduate Research Assistant
Sanavandi, Hamid	Graduate Research Assistant
Xiang, Zhaolong	Visiting Scientist/Researcher
<b>500 - Condensed Matter Science</b>	
Akinfaderin, Adewale Abiodun	Graduate Research Assistant
Aryal, Niraj	Graduate Research Assistant
Bahadur, Divya	Graduate Research Assistant
Baity, Paul	Graduate Research Assistant
Barry, Kevin	Graduate Research Assistant
Bernier, Jacob	Graduate Research Assistant
Bhardwaj, Anish	Graduate Research Assistant
Bindra, Jasleen Kaur	Graduate Research Assistant
Blakeney, Roneisha	Graduate Research Assistant
Chappell, Greta	Graduate Research Assistant
Chen, Kuan-Wen	Graduate Research Assistant
Chiu, Yu Che	Graduate Research Assistant
Cochran, Josiah	Graduate Research Assistant
Ellis, Matthew	Graduate Research Assistant
Eugenio, Paul	Graduate Research Assistant
Franco-Rivera, Giovanni	Graduate Research Assistant
Freeman, Matthew	Graduate Research Assistant
Garcia, Carlos	Graduate Research Assistant
Gebeyehu, Aragaw	Graduate Research Assistant
Geske, Thomas	Graduate Research Assistant
Goodman, Kerestin	Graduate Research Assistant
Gorfien, Matthew	Graduate Research Assistant
Greer, Samuel	Graduate Research Assistant
Hayati, Zahra	Graduate Research Assistant
Henderson, Alyssa	Graduate Research Assistant
Holleman, Joshua	Graduate Research Assistant
Hudis, Jacob	Graduate Research Assistant
Iyiola, Oluwagbenga	Graduate Research Assistant
Jiang, Yuxuan	Postdoctoral Associate
Jolowsky, Claire	Graduate Research Assistant
Jurado, Gabriel	Graduate Research Assistant
Knight, Gary	Graduate Research Assistant
Komijani, Dorsa	Graduate Research Assistant

# Appendix IV – Personnel

Name	Position Title
Lai, You	Graduate Research Assistant
Lakshmi Bhaskaran, FNU	Graduate Research Assistant
Li, Dong	Graduate Research Assistant
Li, Haoran	Graduate Research Assistant
Liou, Shiuan-Fan	Graduate Research Assistant
Liu, Mengtian	Graduate Research Assistant
Liu, Shu	Graduate Research Assistant
Lu, Zhengguang	Graduate Research Assistant
Macy, Juan	Graduate Research Assistant
Marbey, Jonathan	Graduate Research Assistant
Mardani, Masoud	Graduate Research Assistant
Mejia Marin, Juan Jose	Graduate Research Assistant
Memaran, Shahriar	Graduate Research Assistant
Mendoza, Luis Enrique	Graduate Research Assistant
Moon, Seongphill	Graduate Research Assistant
Muhammed, Faheem	Graduate Research Assistant
Nelson, william	Graduate Research Assistant
Neu, Jennifer	Graduate Research Assistant
Nguyen, Nam	Graduate Research Assistant
Parker, Jonathan	Graduate Research Assistant
Peng, Ye	Graduate Research Assistant
Pokharel, Bal	Graduate Research Assistant
Rama Krishna, Sanath Kumar	Graduate Research Assistant
Richardson, Rachael	Graduate Research Assistant
Riner, Lauren	Research Assistant
Roy, Madhuparna	Graduate Research Assistant
Seidler, Kevin	Graduate Research Assistant
Shan, Xin	Graduate Research Assistant
Siddique, Sabrina	Graduate Research Assistant
Stanley, Lily	Graduate Research Assistant
Tan, Yuting	Graduate Research Assistant
Thompson, Christie	Graduate Research Assistant
Tsang, Pak Ki	Graduate Research Assistant
Vakil, Parth	Research Assistant
Wilson, Douglas	Graduate Research Assistant
Zhang, Biwen	Graduate Research Assistant
Zhang, Songlin	Graduate Research Assistant
Zheng, Wenkai	Graduate Research Assistant
Zhou, Chenkun	Graduate Research Assistant
Zhou, Qiong	Graduate Research Assistant
<b>600 - LANL</b>	
Martinez, Nicholas	Graduate Research Assistant
Schmidt, Andrea	Graduate Research Assistant
<b>700 - CIMAR</b>	
Abad, Nastaren	Graduate Research Assistant
Amouzandeh, Ghoncheh	Graduate Research Assistant

# Appendix IV – Personnel

Name	Position Title
Bagdasarian, Frederick	Graduate Research Assistant
Chen, Xuejian	Graduate Research Assistant
Chien, Po-Hsiu	Graduate Research Assistant
Dang, Heather	Graduate Research Assistant
He, Lidong	Graduate Research Assistant
Hike, David	Graduate Research Assistant
Jiang, Tingting	Graduate Research Assistant
Johnston, Taylor	Graduate Research Assistant
Kim, Kyoungmin	Graduate Research Assistant
Krajewski, Logan	Graduate Research Assistant
Li, Xiang	Graduate Research Assistant
Lin, Yuan	Graduate Research Assistant
Liu, Haoyu	Graduate Research Assistant
Liu, Peilu	Graduate Research Assistant
Niles, Sydney	Graduate Research Assistant
O'Neill, Sean	Graduate Research Assistant
Ould Ismail, Abdol Aziz	Graduate Research Assistant
Patel, Sawankumar	Graduate Research Assistant
Popovic, Zeljka	Graduate Research Assistant
Putman, Jonathan	Graduate Research Assistant
Pyo, Seyoun	Graduate Research Assistant
Rose, Alyssa	Graduate Research Assistant
Shin, Yiseul	Graduate Research Assistant
Textor, Sadie	Graduate Research Assistant
Thomas, Jeremy	Graduate Research Assistant
Wang, Kaiyu	Graduate Research Assistant
Wang, Pengbo	Graduate Research Assistant
Ware, Rebecca	Graduate Research Assistant
Xiong, Yi	Graduate Research Assistant
Yuan, Xuegang	Graduate Research Assistant
Zhang, Zhiming	Graduate Research Assistant
Zheng, Jin	Graduate Research Assistant

## 1100 - ASC

Bhattacharai, Kabindra	Graduate Research Assistant
Brown, Michael	Graduate Research Assistant
Chetri, Santosh	Graduate Research Assistant
Collantes, Yesusa	Graduate Research Assistant
Davis, Daniel	Graduate Research Assistant
Francis, Ashleigh	Graduate Research Assistant
Hossain, S Imam	Graduate Research Assistant
Hu, Xinbo	Graduate Research Assistant
Limon, Shah Alam	Graduate Research Assistant
Oloye, Abiola	Graduate Research Assistant
Oz, Yavuz	Graduate Research Assistant
Phifer, Virginia	Graduate Research Assistant
Radcliff, Kyle	Graduate Research Assistant



# Appendix IV – Personnel

Name	Position Title
Segal, Christopher	Graduate Research Assistant
<b>1200 - Director's Office</b>	
Chirinos, Ely	Graduate Research Assistant
Moir, Camilla	Graduate Research Assistant
Schellinger, Jennifer	Graduate Research Assistant
Wartenbe, Mark	Graduate Research Assistant
<b>1300 - Geochemistry</b>	
Bandy, Terryl	Graduate Research Assistant
Behnke, Megan	Graduate Research Assistant
Benayoun, Emily	Graduate Research Assistant
Bosman, Samantha	Graduate Research Assistant
Bowman, Chelsie	Graduate Research Assistant
Carnice, Pearl	Graduate Research Assistant
Davis, Benjamin	Graduate Research Assistant
Fowler, Gary	Graduate Research Assistant
Funderburk, Randall	Graduate Research Assistant
Gfatter, Christian	Graduate Research Assistant
Hannold, Chance	Graduate Research Assistant
Hodgkins, Suzanne	Graduate Research Assistant
Holdaway, Brett	Graduate Research Assistant
Imhoff, Johanna	Graduate Research Assistant
Jahan, Shakura	Graduate Research Assistant
Johnston, Sarah	Graduate Research Assistant
Kelly, Thomas	Graduate Research Assistant
Kozik, Nevin	Graduate Research Assistant
Li, Siqi	Graduate Research Assistant
Lupo, Mary	Graduate Research Assistant
Malinowski, Christopher	Graduate Research Assistant
Mandeville, Justin	Graduate Research Assistant
Newby, Sean	Graduate Research Assistant
Rogers, Kelsey	Graduate Research Assistant
Sun, Fajun	Graduate Research Assistant
Turner, Kyle	Graduate Research Assistant
Zhang, Yin	Graduate Research Assistant

## NSF Category: Undergraduate Student – Total 63

Name	Position Title
<b>100 - Management and Administration</b>	
McClure, Dylan	Programmer
<b>400 - Magnet Science &amp; Technology</b>	
Chen, Qinjie	Research Assistant
Kolb-Bond, Dylan	Research Assistant
Levin, Talya	Undergraduate Research Assistant
Park, Sun	Engineering Technician
<b>500 - Condensed Matter Science</b>	
Anderson, Kelly	Research Assistant

# Appendix IV – Personnel

Name	Position Title
Boone, Zachary	Research Assistant
Brooks, Ashley	Laboratory Assistant / Technician
Centers, Abigail	Research Assistant
Falb, Nathaniel	Research Assistant
Gill, Brooklynn	Research Assistant
Goff, Robert	Research Assistant
Haney, Bobby	Research Assistant
Heflin, Samuel	Research Assistant
Hoadley, Megan	Research Assistant
Lopez-Scarim, Jarrett	Research Assistant
Mciver, Nicolas	Research Assistant
Nicole, Caitlyn	Research Assistant
Reid, Haley	Research Assistant
Scott, Ebony	Research Assistant
Tolbert, Steven	Research Assistant
Walia, Aarushi	Research Assistant
Weatherwax, Allison	Research Assistant
West, Auryndette	Volunteer
Williams, Alan	Laboratory Assistant / Technician
Williams, Jacob	Research Assistant
<b>600 - LANL</b>	
Birnbaum, Serena	Research Assistant
Cordova, Christopher	Undergraduate Student
Follansbee, Emily	Undergraduate Research Assistant
Schneider, Kim	Undergraduate Student
Wigger, James	Undergraduate Research Assistant
<b>700 - CIMAR</b>	
Berliner, Marc	Undergrad Research Assistant
Boebinger, Scott	Undergraduate Research Assistant
Davis, Cameron	Undergraduate Research Assistant
Dimitri, Ian	Undergraduate Research Assistant
Gabler Pizarro, Laura	Undergrad Research Assistant
Gilbertsen, Ryan	Undergraduate Research Assistant
Harmon, Nia	Undergraduate Research Assistant
Le Patourel, Jennifer	Undergraduate Research Assistant
Miranda, Carlos	Undergraduate Research Assistant
Palin, Tara	Undergraduate Research Assistant
Pollack, Alexander	Undergraduate Research Assistant
Sarabia, Leslie	Undergraduate Research Assistant
<b>1100 - ASC</b>	
Boyd, Joshua	Laboratory Assistant-Level 2
Chambers, Austin	Laboratory Assistant-Level 2
Cooper, Jonathan	Laboratory Assistant-Level 2
Khwaja, Eisa	Laboratory Assistant-Level 2
Nelson, Kali	Laboratory Assistant- Level 2
Quiroz, Fernando	Laboratory Assistant-Level 2

# Appendix IV – Personnel

Name	Position Title
Shelby, Taylor	Laboratory Assistant - Level 2
Small, Michael	Laboratory Assistant- Level 1
Walker, Benjamin	Laboratory Assistant- Level 3

## 1300 - Geochemistry

Calero, Adolfo	Undergraduate Research Assistant
DesRosiers, Mary	Undergraduate Research Assistant
Green, Shelby	Undergraduate Research Assistant
Langford, Dalton	Undergraduate Research Assistant
Nowotarski, Mesopotamia	Undergraduate Research Assistant
Pullon, Alton	Undergraduate Research Assistant
Renegar, Kaitlyn	Undergraduate Research Assistant
Richbourg, Claudia	Undergraduate Research Assistant
Rogers, Jennifer	Undergraduate Research Assistant
Spake, Travis	Undergraduate Research Assistant
Westberry, Shelby	Undergraduate Research Assistant

## NSF Category: Staff - Technical/Managerial – Total 94

Name	Position Title
<b>100 - Management and Administration</b>	
Avant, Michael	Electrician
Barker, William	Campus Service Assistant
Bhat, Akash	Programmer Intern
Braverman, Kenneth	Research Assistant
Buchek, Jackie	Lab Program and Air Resources Manager
Caceres, Desiree	Maintenance Engineer
Castano, Marcela	Maintenance Engineer
Childs, John	Media Specialist (Graphic Artist)
Cone, Raymond	Mechanical Assistant
Coyne, Sean	Facilities Engineer
Davis, Darian	AC Technician, Electrician
Ferrell, Scott	Welder
Finn, Sarita	Web Designer/Programmer
Gamble, Kevin	Facilities Superintendent
Hahn, David	Web Application Developer
Heeg, Joseph	Mechanical Technician
Himler, Tammy	Maintenance Superintendent
John, Kevin	Media Specialist (Graphic Artist)
Johnson, Steve	Maintenance Mechanic
Kirschner, Matthew	Systems Programmer
Lewis, Raymond	Scientific & Research Technician
Ludlow, Richard	Media Specialist (Graphic Artist)
Mosley, Kelly	Welder
Nixon, Willie	Scientific & Research Technician
Oxendine, Christopher	Scientific & Research Technician
Pagel, Don	Maintenance Mechanic
Phinazee, Billy	Maintenance Mechanic

# Appendix IV – Personnel

Name	Position Title
Price, Daniel	AC Technician
Rettig, Andrew	Technical Support Analyst
Robinson, Paul	Maintenance Mechanic
Shreve, Rodney	Industrial Engineer
Slavichak, Stacy	Water Resources Manager
Stevens, Dustin	Mechanical Trades Technician
Stockford, Matthew	Skilled Trades Worker
Szelong, Dustin	Technology Specialist
Young, Aaron	Engineer Technician
<b>300 - DC Instrumentation</b>	
Bonninghausen, Russell	Technical/Research Designer
Brehm, William	Technician/Research Designer
Carrier, Robert	Technical/Research Designer
Freeman, Daniel	Technical/Research Designer
Gordon, Larry	Scientific Research Specialist
Hicks, Michael	Technical/Research Designer
Oloff, Morgan	Technical/Research Designer
Piotrowski, Joel	Technical/Research Designer
Pullum, Bobby	Scientific & Research Technician
Sloan, David	Technician/Research Designer
Thomas, Christopher	Technical/Research Designer
Torres Camacho, Jesus	Technical/Research Designer
<b>400 - Magnet Science &amp; Technology</b>	
Arroyo, Erick	Technical Research Designer
Deterding, Justin	Research Engineer
Helms, Randy	Technical Research/Designer
Levitan, Jeremy	Research Engineer
Ray, Christopher	Research Engineer
Stevens, Allison	Research Assistant
Windham, Carl	Research Assistant
<b>500 - Condensed Matter Science</b>	
Pope, Phillip	Research Assistant
Revell, Hannah	Research Assistant
Slade III, James	Research Assistant
Wackes, Elisabet	Laboratory Assistant / Technician
<b>600 - LANL</b>	
Coulter, Yates	Head of Generator Operations
Gordon, Michael	Research Technologist
Lucero, Jason	Research Technician
Martin, Jeff	Controls Specialist
Michel, James	Research Technologist
Pacheco, Michael	Research and Development Technologist
Roybal, Darrell	Research Technician
Sattler, Dave	Designer
Teshima, Hazuki	Research Technician
Vigil, Billy	Research & Development Technologist

# Appendix IV – Personnel

Name	Position Title
Vigil, Marcos	Research Technician
<b>700 - CIMAR</b>	
Blue, Ashley	Technical/Research Designer
Desilets, Richard	Technical/Research Designer
Donthineni, Sri	High School Intern
Helsper, Shannon	MRI Animal Technician
Henricks, Henry	Laboratory Assistant / Technician
Kelley, Donovan	Laboratory Assistant / Technician
McCall, Jackson	High School Intern
Taylor, Joshua	Research Technician
Towles, James (Kaleb)	Laboratory Assistant / Technician
White, Michelle	High School Intern
<b>800 - UF</b>	
Collins, James	Core Research Facility Manager
Kaye Steadman, Judith	MRI Technologist
Slade, Joshua	Engineering Technician
Swiers, Christi	MRI Technologist
Webb, Elizabeth	Coordinator, Research Programs / Services
<b>1100 - ASC</b>	
Bradford, Griffin	Research Assistant
English, Charles	Research Engineer
Gillman, James	Research Engineer
Miller, Evan	Laboratory Assistant-Level 2
Zhang, Zhenyu	Postdoctoral Associate
<b>1200 - Director's Office</b>	
Bryan, Michael	Fire Safety Tech
<b>1300 - Geochemistry</b>	
Fish, Brandon	Graduate Research Assistant
Wolff, Burt	Assistant in Research
Zateslo, Theodore	Senior Engineer
<b>NSF Category: Staff - Secretarial/Clerical – Total 27</b>	
Name	Position Title
<b>100 - Management and Administration</b>	
Anderson, Shelby	Program Assistant
Burton, Gwendolyn	UBA Business Associate
Cherisol, Luc	Accounting Representative
Hacker, Miranda	Office Administrator
Hermance, Scott	Campus Service Assistant
Hicks, Cheryl	UBA Business Associate
Hill, Philip	Program Associate
Hooley, Melanie	Accounting Assistant
Joiner, Karen	Admin Support Assistant
Lang, Angelena	Accounting Assistant
Qureshi, Saadiyah	Clerk
Sapronetti, Andrew	Administrative Associate (Non-Exempt)

# Appendix IV – Personnel

Name	Position Title
Stafford, Holly	Administrative Support Assistant
<b>400 - Magnet Science &amp; Technology</b>	
Maddox, James	Program Associate
<b>500 - Condensed Matter Science</b>	
Qureshi, Aisha	Administrative Assistant
<b>600 - LANL</b>	
Cervantes Herrera, Jessica	Group Administrator
Gallegos, Julie	Program Administrator
<b>700 - CIMAR</b>	
Desilets, Mary	Administrative Support Assistant
Jemmott, Krista	Program Associate
Mozolic, Kimberly	Program Associate
<b>800 - UF</b>	
Colson, Marcia Tessie	Program Assistant
Mesa, Denise	NHMFL Administrative Assistant
<b>1100 - ASC</b>	
English, Denise	Office Assistant
Hall, Charlotte	Admin Support Assistant
<b>1200 - Director's Office</b>	
Davis, Colleen	Program Coordinator
Engleman, Abigail	Intern
Fitch, Morgan	Program Associate

# Appendix IV – Personnel

Table includes the statistic of all 2017 personnel housed at the MagLab at FSU, UF, and LANL.

Parameter/Category	Demographic Classification	Gender	Senior Personnel	Postdoc	Other Professional	Graduate Student	Undergraduate Student	Support Staff Technical/ Managerial	Support Staff Secretarial/ Clerical	Total	%	
Gender	Male		189	40	64	96	36	79	5	509	71.2%	
			189	40	64	96	36	79	5	509	71.2%	
	Female		31	16	29	66	27	12	22	203	28.4%	
			31	16	29	66	27	12	22	203	28.4%	
	Other		0	0	0	0	0	0	0	0	0.0%	
			0	0	0	0	0	0	0	0	0.0%	
	Prefer Not to Respond		0	0	0	0	0	0	3	0	3	0.4%
			0	0	0	0	0	0	3	0	3	0.4%
TOTAL			220	56	93	162	63	94	27	715	100.0%	
Race	White	Male	138	18	58	42	29	65	3	353	49.3%	
		Female	22	8	26	29	20	9	17	131	18.3%	
		Other	0	0	0	0	0	0	0	0	0.0%	
		Prefer Not to Respond	0	0	0	0	0	0	0	0	0.0%	
		TOTAL	160	26	84	71	49	74	20	484	67.6%	
	Black or African American	Male	3	2	3	7	4	6	1	26	3.6%	
		Female	0	1	1	7	5	1	3	18	2.5%	
		Other	0	0	0	0	0	0	0	0	0.0%	
		Prefer Not to Respond	0	0	0	0	0	0	0	0	0.0%	
		TOTAL	3	3	4	14	9	7	4	44	6.2%	
	Native Hawaiian or Pacific Islander	Male	0	0	0	2	0	0	0	0	2	0.3%
		Female	0	0	0	0	0	0	0	0	0	0.0%
		Other	0	0	0	0	0	0	0	0	0	0.0%
		Prefer Not to Respond	0	0	0	0	0	0	0	0	0	0.0%
		TOTAL	0	0	0	2	0	0	0	0	2	0.3%
	Asian	Male	48	20	3	40	2	3	0	116	16.2%	
		Female	9	7	2	29	1	1	2	51	7.1%	
		Other	0	0	0	0	0	0	0	0	0.0%	
		Prefer Not to Respond	0	0	0	0	0	0	0	0	0.0%	
		TOTAL	57	27	5	69	3	4	2	167	23.4%	
	American Indian or Alaska Native	Male	0	0	0	2	0	1	1	4	0.6%	
		Female	0	0	0	1	0	0	0	1	0.1%	
		Other	0	0	0	0	0	0	0	0	0.0%	
		Prefer Not to Respond	0	0	0	0	0	0	0	0	0.0%	
		TOTAL	0	0	0	3	0	1	1	5	0.7%	
	More Than One	Male	0	0	0	1	1	1	0	3	0.4%	
Female		0	0	0	0	0	0	0	0	0.0%		

# Appendix IV – Personnel

Parameter/Category	Demographic Classification	Gender	Senior Personnel	Postdoc	Other Professional	Graduate Student	Undergraduate Student	Support Staff Technical/ Managerial	Support Staff Secretarial/ Clerical	Total	%	
		Other	0	0	0	0	0	0	0	0	0.0%	
		Prefer Not to Respond	0	0	0	0	0	0	0	0	0.0%	
			0	0	0	1	1	1	0	3	0.4%	
	Prefer Not to Respond	Male	0	0	0	2	0	3	0	5	0.7%	
		Female	0	0	0	0	1	1	0	2	0.3%	
		Other	0	0	0	0	0	0	0	0	0.0%	
		Prefer Not to Respond	0	0	0	0	0	3	0	3	0.4%	
		TOTAL	0	0	0	2	1	7	0	10	1.4%	
		TOTAL	220	56	93	162	63	94	27	715	100.0%	
	Ethnicity	Hispanic or Latino	Male	6	3	3	7	5	8	0	32	4.5%
Female			1	2	2	2	3	0	2	12	1.7%	
Other			0	0	0	0	0	0	0	0	0.0%	
Prefer Not to Respond			0	0	0	0	0	0	0	0	0.0%	
TOTAL			7	5	5	9	8	8	2	44	6.2%	
Not Hispanic or Latino		Male	183	37	61	89	30	67	5	472	66.0%	
		Female	30	14	27	64	23	11	20	189	26.4%	
		Other	0	0	0	0	0	0	0	0	0.0%	
		Prefer Not to Respond	0	0	0	0	0	0	0	0	0.0%	
		TOTAL	213	51	88	153	53	78	25	661	92.4%	
Prefer Not to Respond		Male	0	0	0	0	1	4	0	5	0.7%	
		Female	0	0	0	0	1	1	0	2	0.3%	
		Other	0	0	0	0	0	0	0	0	0.0%	
		Prefer Not to Respond	0	0	0	0	0	3	0	3	0.4%	
		TOTAL	0	0	0	0	2	8	0	10	1.4%	
TOTAL		220	56	93	162	63	94	27	715	100.0%		
Disability		Yes	Male	1	0	0	5	1	0	0	7	1.0%
			Female	0	1	0	1	0	0	0	2	0.3%
			Other	0	0	0	0	0	0	0	0	0.0%
	Prefer Not to Respond		0	0	0	0	0	0	0	0	0.0%	
	TOTAL		1	1	0	6	1	0	0	9	1.3%	
	No	Male	188	40	64	91	34	75	5	497	69.5%	
		Female	31	15	29	65	27	11	22	200	28.0%	
		Other	0	0	0	0	0	0	0	0	0.0%	
		Prefer Not to Respond	0	0	0	0	0	0	0	0	0.0%	
		TOTAL	219	55	93	156	61	86	27	697	97.5%	
Prefer Not to	Male	0	0	0	0	1	4	0	5	0.7%		



# Appendix IV – Personnel

Parameter/ Category	Demographic Classification	Gender	Senior Personnel	Postdoc	Other Professional	Graduate Student	Undergraduate Student	Support Staff Technical/ Managerial	Support Staff Secretarial/ Clerical	Total	%	
	Respond	Female	0	0	0	0	0	1	0	1	0.1%	
		Other	0	0	0	0	0	0	0	0	0.0%	
		Prefer Not to Respond	0	0	0	0	0	0	3	0	3	0.4%
		TOTAL	0	0	0	0	0	1	8	0	9	1.3%
	TOTAL		220	56	93	162	63	94	27	715	100.0%	
TOTAL COUNTS			220	56	93	162	63	94	27	715	100.0%	
TOTAL PERCENTAGE			30.80%	7.80%	13.00%	22.70%	8.80%	13.10%	3.80%	100.00%		



# Appendix V – Postdoctoral Mentoring Plan

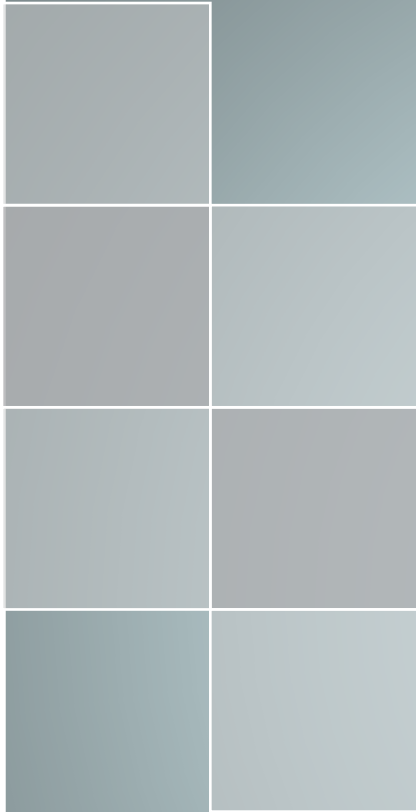

# Appendix V – Postdoc Mentoring Plan

## MagLab Postdoctoral Mentoring Plan

The goal of the Postdoctoral Mentoring Plan at the National High Magnetic Field Laboratory (MagLab) is to provide MagLab postdoctoral associates with a complete skill set that addresses the modern challenges of a career in science, technology, engineering, and mathematics (STEM). A key component of the plan is full immersion in the interdisciplinary culture of the MagLab and in the surrounding communities of one of the MagLab's three partner institutions - the Florida State University (FSU), the University of Florida (UF), and Los Alamos National Laboratory (LANL). The Center for Integrating Research and Learning (CIRL), housed within the MagLab, will facilitate this Postdoctoral Mentoring Plan.

Currently, MagLab postdoctoral researchers are required by their supervisors and research groups to participate in the preparation of publications, and to make presentations at group meetings and conferences. Postdoctoral researchers are also expected to play active roles in STEM-strengthening programs, such as the MagLab Diversity Plan, outreach efforts, and formal educational or mentoring programs (e.g. the Research Experiences for Undergraduates program, the Research Experiences for Teachers program, and other CIRL outreach programs, through which they can provide significant STEM mentorship to students, early career scientists, and the teachers of the next generation of scientists). Finally, MagLab postdoctoral associates are expected to provide service to the Laboratory through participation in the MagLab Annual Open House or other events designed specifically to translate and communicate research in the MagLab user community to members of the general public.

### Key components of the Postdoctoral Mentoring Plan are:

- **Orientation.** Orientations where new employees meet with the MagLab Director and the Human Resources Director who address questions they may have related to their new position and the Lab are held quarterly for all new employees, including postdocs. Orientation materials, including a "Welcome to the MagLab" document, are available online to augment the face-to-face orientation. The postdocs at the Lab have developed an additional orientation booklet that speaks to the unique issues postdocs face. Orientation includes an overview of:

the three sites of the MagLab, the breadth of scientific research in the MagLab user program, particularly interdisciplinary research, and practical institutional information (including but not limited to performance expectations, salary information, the ordering and delivery of materials, as well as information about local housing, schools, health care resources, and links to special interest groups at the local partner institution).

- **Professional Development.** Professional development classes, workshops, and online materials will cover grant writing, ethical conduct of research, organizing data, writing manuscripts, giving effective scientific presentations, mentoring other scientists and communicating scientific research to non-scientists. Workshops will be facilitated by CIRL and involve faculty from the MagLab sites, the FSU Career Center, national postdoc associations, and industry partners.
- **Career Counseling.** Sometimes postdoctoral associates may have career questions that their assigned mentor cannot speak to (e.g. careers in industry, networking opportunities for underrepresented minority students). Therefore, the MagLab Postdoctoral Mentoring Plan includes a list of additional volunteer mentors who are willing to answer questions that postdoctoral associates may have. Postdoctoral associates may choose to contact volunteers from this list if they feel they need additional advice not exclusively from their direct supervisor. Possible forms of advice include: providing guidance, encouragement, and information on opportunities for networking, contributed and invited talks, and travel funds to attend conferences, including the MagLab's Dependent Care Travel Grant Program [<https://nationalmaglab.org/user-resources/funding-opportunities>].
- **Assessment.** Assessment will be conducted by CIRL through the analysis of annual evaluation surveys to determine topics of interest to postdoctoral researchers and to ensure that postdoctoral researchers are being well mentored.



# Appendix VI– User Proposals



# Appendix VI – User Proposals

		Participants (Name, Role, Org., Dept.)		Funding Sources (Funding Agency, Division, Award #)		Proposal #	Proposal Title	Discipline	Exp. #	Days Used
Joanna Long (S)	PI	University of Florida	Biochemistry & Molecular Biology	Not provided		P17542	New user training (formerly P09511)	Biology, Biochemistry, Biophysics	1	63.72
James Collins (P)	C	University of Florida	Biochemistry & Molecular Biology							
Tan Nguyen (U)	C	University of Florida	Biochemistry and Molecular Biology							
James Rocca (S)	C	University of Florida	AMRIS Affiliated Faculty & Staff							
Huadong Zeng (S)	C	University of Florida	AMRIS Affiliated Faculty & Staff							
Joanna Long (S)	PI	University of Florida	Biochemistry & Molecular Biology	Not provided		P17541	Routine maintenance of existing equipment (formerly P09510)	Biology, Biochemistry, Biophysics	1	400.58
James Collins (P)	C	University of Florida	Biochemistry & Molecular Biology							
Kelly Jenkins (T)	C	University of Florida	AMRIS Affiliated Faculty & Staff							
Thomas Mareci (S)	C	University of Florida	Biochemistry and Molecular Biology							
Tammy Nicholson (T)	C	University of Florida	AMRIS Affiliated Faculty & Staff							
James Rocca (S)	C	University of Florida	AMRIS Affiliated Faculty & Staff							
Joshua Slade (T)	C	University of Florida	AMRIS							
Huadong Zeng (S)	C	University of Florida	AMRIS Affiliated Faculty & Staff							
Joanna Long (S)	PI	University of Florida	Biochemistry & Molecular Biology	Not provided						
Kelly Jenkins (T)	C	University of Florida	AMRIS Affiliated Faculty & Staff							
Huadong Zeng (S)	C	University of Florida	AMRIS Affiliated Faculty & Staff							
Joanna Long (S)	PI	University of Florida	Biochemistry & Molecular Biology	No other support (i.e. this experiment is entirely supported by NHMFL users services via its core grant)		P17539	New equipment/upgrades/troubleshooting on verticals (formerly P09507)	Biology, Biochemistry, Biophysics	1	100.23
Jennifer Isaacs (S)	C	Medical University of South Carolina	Cell and Molecular Pharmacology							
James Collins (P)	C	University of Florida	Biochemistry & Molecular Biology							

# Appendix VI – User Proposals

		Participants (Name, Role, Org., Dept.)		Funding Sources (Funding Agency, Division, Award #)			Proposal #	Proposal Title	Discipline	Exp. #	Days Used
Daniel Downes (G)	C	University of Florida	Biochemistry and molecular biology								
James Rocca (S)	C	University of Florida	AMRIS Affiliated Faculty & Staff								
Joshua Slade (T)	C	University of Florida	AMRIS								
Rodolfo Gatto (S)	PI *	University of Illinois at Chicago	Bioengineering	Chicago Biomedical Consortium			<b>P17430</b>	Structural Analysis of Early Axonal Degeneration in ALS by MRI Diffusion Methods.	Biology, Biochemistry, Biophysics	1	4
Manish Amin (G)	C	University of Florida	Physics								
Luis Colon-perez (P)	C	University of Florida	Psychiatry								
Jin Gao (G)	C	University of Illinois at Chicago	Biomedical Engineering								
Weiguo Li (T)	C	University of Illinois at Chicago	Bioengineering								
Richard Magin (S)	C	University of Illinois at Chicago	Bioengineering								
Thomas Mareci (S)	C	University of Florida	Biochemistry and Molecular Biology								
Asahi Tomitaka (P)	PI *	Florida International University	Department of Immunology	Not provided			<b>P17422</b>	Brain-targeted image-guided drug delivery for HIV treatment	Biology, Biochemistry, Biophysics	1	1
Luis Colon-perez (P)	C	University of Florida	Psychiatry								
Marcelo Febo (S)	C	University of Florida	Psychiatry								
Robert Huigens (G)	PI *	University of Florida	Medicinal Chemistry	University of Florida, College of Pharmacy startup			<b>P17386</b>	Development of Halogenated Phenazine Prodrugs and Antibiotic Conjugates as Antibacterial Therapeutics	Chemistry, Geochemistry	1	70.06
Yasmeen Abouelhassan (G)	C	University of Florida	Medicinal Chemistry								
Nicholas Paciaroni (G)	C	University of Florida	Medicinal Chemistry								
hongfen Yang (G)	C	University of Florida	college of pharmacy medicinal chemistry								
David Harris (S)	PI *	Northwestern University	Chemistry	DOD - Department of Defense	U.S. Air Force	FA8650-15-5518	<b>P16314</b>	pH Mapping of Extracellular Space in Mice Tumors Using a Ratiometric Co2 PARACEST Probe	Biology, Biochemistry, Biophysics	1	3.33

# Appendix VI – User Proposals

Participants (Name, Role, Org., Dept.)		Funding Sources (Funding Agency, Division, Award #)		Proposal #	Proposal Title	Discipline	Exp. #	Days Used
James Collins (P)	C	University of Florida	Biochemistry & Molecular Biology	Northwestern University startup funds				
Kang Du (G)	C	Northwestern University	Chemistry					
Agnes Thorarinsdottir (G)	C	Northwestern University	Chemistry					
Glenn Walter (S)	C	University of Florida	Physiology and Functional Genomics					
Yousong Ding (S)	PI	University of Florida	Medicinal Chemistry	University of Florida, startup package	<b>P16310</b>	Discovery of bioactive microbial metabolites via synthetic biology approaches	1	5.35
Guangde Jiang (G)	C	University of Florida	Medicinal Chemistry	Air Force, Office of Scientific Research				
Yi Zhang (S)	C	University of Florida	Pharmacology					
Yi Zhang (G)	C	University of Florida	Medicinal Chemistry					
Ran Zuo (G)	C	University of Florida	Medicinal Chemistry					
Lilibeth Salvador (S)	PI *	University of the Philippines	Marine Science Institute	University of the Philippines	<b>P16297</b>	Structural characterization of marine toxins from Philippine organisms	1	25.82
Jeremiah Batucan (G)	C	University of the Philippines	Marine Science Institute			Biology, Biochemistry, Biophysics		
Hendrik Luesch (S)	C	University of Florida						
James Rocca (S)	C	University of Florida	AMRIS Affiliated Faculty & Staff					
Malisa Sarntinoranont (S)	PI	University of Florida		Chiari & Syringomyelia Foundation	<b>P16254</b>	Mapping Perivascular Connectome in Whole Rat Brain in 3D	1	46.25
Michael King (S)	C	University of Florida	Pharmacology and Therapeutics					
Magdoom Mohamed Kulam Najmudeen (G)	C	University of Florida	Mechanical and Aerospace Engineering					
Thomas Mareci (S)	C	University of Florida	Biochemistry and Molecular Biology					
Joshua Yarrow (S)	C	Malcom Randall VA Medical Center	Center of Innovation on Disability & Rehabilitation Research					

# Appendix VI – User Proposals

		Participants (Name, Role, Org., Dept.)		Funding Sources (Funding Agency, Division, Award #)			Proposal #	Proposal Title	Discipline	Exp. #	Days Used
Thomas Mareci (S)	PI	University of Florida	Biochemistry and Molecular Biology	NIH - National Institutes of Health	NCATS - National Center for Advancing Translational Sciences	TR000064	<b>P16225</b>	Gradient Eddy Current Pre-emphasis with Uniform Excitation of Eigenmodes	Biology, Biochemistry, Biophysics	1	18.08
William Brey (S)	C	National High Magnetic Field Laboratory (NHMFL)	NMR								
Magdoo Mohamed Kulam	C	University of Florida	Mechanical and Aerospace Engineering								
Najmudeen (G)	C	Ohio State University	Department of Neurological Surgery								
Russel Lonser (S)	C	University of Florida									
Malisa Sarntinoranont (S)	C	University of Florida									
Andrew Maurer (S)	PI *	University of Florida	Neuroscience	NIH - National Institutes of Health	NIA - National Institute on Aging	AG055544	<b>P16198</b>	Alterations in the Thalamic Reunions projections in the Aged Rat	Biology, Biochemistry, Biophysics	1	34
Jen Bizon (S)	C	University of Florida	Neuro	UF MBI - McKnight Brain Institute							
Sara Burke (S)	C	University of Florida	Neuroscience								
Jeremy Flint (S)	C	University of Florida	Neuroscience								
Aaron Mattfeld (S)	C	Florida International University	Psychology								
Kannan Menon (G)	C	University of Florida	Neuroscience								
Kimberly Robertson (T)	C	University of Florida	Neuroscience								
Lilit Vardanyan (P)	PI *	University of Florida	Soil and Water Science	Not provided			<b>P16145</b>	Identification and Quantification of Organic Phosphorus Forms in the Soils of the Everglades Stormwater Treatment Areas (STAs)	Biology, Biochemistry, Biophysics	1	17.17
K. Ramesh Reddy (S)	C	University of Florida	Soil & Water Science								
Michael Bowman (S)	PI *	University of Alabama, Tuscaloosa	Chemistry	NSF - National Science Foundation	CHE – Division of Chemistry	CHE1416238	<b>P16066</b>	Spin Dynamics of DNP Samples	Chemistry, Geochemistry	1	3
Hanjiao Chen (G)	C	University of Alabama,	Chemistry								



# Appendix VI – User Proposals

Participants (Name, Role, Org., Dept.)		Funding Sources (Funding Agency, Division, Award #)			Proposal #	Proposal Title	Discipline	Exp. #	Days Used		
Tuscaloosa											
James Collins (P)	C	University of Florida	Biochemistry & Molecular Biology								
Benjamin Fowler (G)	C	University of Alabama	Chemistry								
Bimala Lama (P)	C	University of Florida	Biochemistry and Molecular Biology								
Joanna Long (S)	C	University of Florida	Biochemistry & Molecular Biology								
Robert Huigens (G)	PI *	University of Florida	Medicinal Chemistry	University of Florida, College of Pharmacy		<b>P16046</b>	Structure Elucidation of Complex and Diverse Small Molecules from Vincamine Using High-Field NMR	Chemistry, Geochemistry	1	44.67	
Chip Norwood (G)	C	University of Florida	Medicinal Chemistry								
Hae-Kwon Jeong (S)	PI	Texas A&M University	Chemical Engineering, Materials Science and Engi	NSF - National Science Foundation	CMMI - Division of Civil, Mechanical & Manufacturing Innovation	CMMI1561347	<b>P14981</b>	Transport properties of mesoporous metal-organic frameworks by high field diffusion NMR	Engineering	1	25.83
Akshita Dutta (G)	C	University of Florida	Chemical Engineering								
Sergey Vasenkov (S)	C	University of Florida	Chemical Engineering								
Wenyu Huang (S)	PI	Iowa State University	Chemistry	NSF - National Science Foundation	CHE – Division of Chemistry	CHE1507230	<b>P14961</b>	DNP Solid-State MAS NMR Studies of Advanced Catalytic Nanomaterials to Complement Parahydrogen Induced Polarization Studies	Chemistry, Geochemistry	1	11
Clifford Bowers (S)	C	University of Florida	Chemistry	Iowa State University							
Yong Du (G)	C	University of Florida	chemistry								
Wenyu Huang (S)	C	Iowa State University	Chemistry								
Frederic Mentink (S)	C	National High Magnetic Field Laboratory (NHMFL)	NMR Division								
Evan Wenbo Zhao (G)	C	University of Florida	Chemistry								
Tommy Zhao (G)	C	University of Florida	Chemistry								
Joanna Long (S)	PI	University of Florida	Biochemistry & Molecular Biology	No other support (i.e. this experiment is entirely supported by		<b>P14952</b>	Study of electron relaxation times of radicals under conditions relevant for hyperpolarization techniques	Biology, Biochemistry, Biophysics	1	0.33	

# Appendix VI – User Proposals

Participants (Name, Role, Org., Dept.)		Funding Sources (Funding Agency, Division, Award #)		Proposal #	Proposal Title	Discipline	Exp. #	Days Used	
Bimala Lama (P)	C	University of Florida	Biochemistry and Molecular Biology	NHMFL users services via its core grant)					
Johannes McKay (P)	C	Keysight Technologies	MMIC Microwave						
Frederic Mentink (S)	C	National High Magnetic Field Laboratory (NHMFL)	NMR Division						
Adam Smith (P)	C	University of Florida	Chemistry						
Johan van Tol (S)	C	National High Magnetic Field Laboratory (NHMFL)	EMR						
Xiaoling Wang (P)	C	National High Magnetic Field Laboratory (NHMFL)	NMR						
Rebecca Butcher (S)	PI	University of Florida	Chemistry						Not provided
Rachel Jones (P)	C	University of Florida	Chemistry						
Fatma Kaplan (S)	C	Kaplan Schiller Research, LLC	N/A						
Alexandra Roder (G)	C	University of Arizona	Entomology						
Prashant Singh (G)	C	University of Florida	Chemistry						
S. Patricia Stock (S)	C	University of Arizona	Entomology						
Yuting Wang (G)	C	University of Florida	Chemistry						
Marcus Bäumer (S)	PI	University Bremen	Institute of Applied and Physical Chemistry	German Science Foundation (DFG)	<b>P14801</b>	Transport properties of nanoporous gold by high field NMR diffusometry	Chemistry, Geochemistry	1	20
Amineh Baniani (G)	C	University of Florida	Chemical Engineering						
Evan Forman (G)	C	University of Florida	Chemical Engineering						
Sergey Vasenkov (S)	C	University of Florida	Chemical Engineering						
Arne Wittstock (S)	C	University Bremen	Chemistry						

# Appendix VI – User Proposals

Participants (Name, Role, Org., Dept.)				Funding Sources (Funding Agency, Division, Award #)			Proposal #	Proposal Title	Discipline	Exp. #	Days Used
JR Schmidt (S)	PI	University of Wisconsin, Madison	Chemistry	DOE - Department of Energy	Office of Science - BES – Basic Energy Sciences	DE-SC0012577	<b>P14791</b>	H2S diffusion in metal-organic frameworks by high field PFG NMR	Engineering	1	44.33
Akshita Dutta (G)	C	University of Florida	Chemical Engineering								
Evan Forman (G)	C	University of Florida	Chemical Engineering								
Ryan Lively (S)	C	Georgia Institute of Technology	School of Chemical & Biomolecular Engineering,								
Sergey Vasenkov (S)	C	University of Florida	Chemical Engineering								
Kirk Ziegler (S)	C	University of Florida	Chemical Engineering								
Scott Prosser (S)	PI	University of Toronto	Chemistry and Biochemistry	Natural Sciences and Engineering Research Council Canada			<b>P14670</b>	In vivo Detection and Quantification of Protein Clearance using 13C-filtered MRI and MRS	Biology, Biochemistry, Biophysics	1	1.5
Daniel Downes (G)	C	University of Florida	Biochemistry and molecular biology								
Advait Hasabnis (G)	C	University of Toronto	Biochemistry/Chemistry								
Joanna Long (S)	C	University of Florida	Biochemistry & Molecular Biology								
Huadong Zeng (S)	C	University of Florida	AMRIS Affiliated Faculty & Staff								
Ryan Lively (S)	PI	Georgia Institute of Technology	School of Chemical & Biomolecular Engineering,	NSF - National Science Foundation	CBET - Chemical, Bioengineering, Environmental, and Transport Systems	CBET1510411	<b>P11493</b>	Relationship between single component and gas mixture diffusion in porous membranes and nanotubes by pulsed field gradient NMR	Engineering	1	66.08
Amineh Baniani (G)	C	University of Florida	Chemical Engineering	NSF - National Science Foundation	CBET - Chemical, Bioengineering, Environmental, and Transport Systems	CBET1510442					
Clifford Bowers (S)	C	University of Florida	Chemistry								
Akshita Dutta (G)	C	University of Florida	Chemical Engineering								
Lei Fan (G)	C	University of Florida	Chemical engineering								

# Appendix VI – User Proposals

Participants (Name, Role, Org., Dept.)		Funding Sources (Funding Agency, Division, Award #)		Proposal #	Proposal Title	Discipline	Exp. #	Days Used		
Evan Forman (G)	C	University of Florida	Chemical Engineering							
Sergey Vasenkov (S)	C	University of Florida	Chemical Engineering							
Erkang Zhou (G)	C	Georgia Institute of Technology	School of Chemical & Biomolecular Engineering,							
Kirk Ziegler (S)	C	University of Florida	Chemical Engineering							
Mavis Agbandje-McKenna (S)	PI *	University of Florida	Biochemistry and Molecular Biology	No other support (i.e. this experiment is entirely supported by NHMFL users services via its core grant)	<b>P02429</b>	Unveiling the structure and dynamics of the infectivity domain of AAV, a gene therapy vector, using a 600 MHz NMR spectrometer with a cryo-probe.	Biology, Biochemistry, Biophysics	1	14.5	
Matthew Burg (G)	C	University of Florida	Chemistry							
Renuk Lakshmanan (T)	C	University of Florida	Biochemistry and Molecular Biology							
Joanna Long (S)	C	University of Florida	Biochemistry & Molecular Biology							
Gwladys Riviere (P)	C	University of Florida	Biochemistry and molecular biology							
Ben Turner (S)	PI	Smithsonian Tropical Research Institute		NSF - National Science Foundation	DGE-1315138	<b>P02293</b>	The stability and reactivity of organic matter in peat wetland ecosystems	Chemistry, Geochemistry	1	15.75
Benjamin Baisier (S)	C	University of Florida	Wildlife Ecology	NSF - National Science Foundation	NSF GROW and GRIP travel awards					
Mark Clark (S)	C	University of Florida	Soil and Water Sciences							
Samantha Grover (P)	C	La Trobe University	Centre for AgriBioscience							
Chelsea Hazlett (U)	C	University of Florida	Soil and Water Sciences							
Evan Kane (S)	C	Michigan Tech	Forest Resources and Environmental Studies							
Erik Lilleskov (S)	C	US Forest Service	Northern Research Station							
Joanna Long (S)	C	University of Florida	Biochemistry & Molecular Biology							

# Appendix VI – User Proposals

Participants (Name, Role, Org., Dept.)		Funding Sources (Funding Agency, Division, Award #)		Proposal #	Proposal Title	Discipline	Exp. #	Days Used	
Anna Normand (G)	C	University of Florida	Soil and Water Science						
K. Ramesh Reddy (S)	C	University of Florida	Soil & Water Science						
Adam Smith (P)	C	University of Florida	Chemistry						
Matthew Erickson (S)	PI	University of Florida	ER	No other support (i.e. this experiment is entirely supported by NHMFL users services via its core grant)	<b>P02196</b>	Augmented Tune/Match Circuits for High Performance Dual Nuclear Transmission Line Resonators.	Biology, Biochemistry, Biophysics	1	2.33
<b>Total Proposals:</b>							<b>27</b>		
<b>Experiments:</b>							<b>27</b>		
<b>Days:</b>								<b>1,124.00</b>	

\* = A new PI for the reporting year.

PI = Principal Investigator; C = Collaborator

S = Senior Personnel; P = Postdoc; G = Graduate Student; U = Undergraduate Student; T = Technician, programmer

# Appendix VI – User Proposals

Participants (Name, Role, Org., Dept.)		Funding Sources (Funding Agency, Division, Award #)			Proposal #	Proposal Title	Discipline	Exp. #	Days Used		
Mykhaylo Ozerov (S)	PI *	National High Magnetic Field Laboratory (NHMFL)	Condensed Matter Science, DC Field CMS	No other support (i.e. this experiment is entirely supported by NHMFL users services via its core grant)		P17373	FTIR magneto-spectroscopy in the NHMFL DC facility: new developments, tests and optimization of experimental protocols	Magnets, Materials, Testing, Instrumentation	2	9.7	
Dmitry Semenov (T)	C	National High Magnetic Field Laboratory (NHMFL)	DC Field								
Dmitry Smirnov (S)	C	National High Magnetic Field Laboratory (NHMFL)	Instrumentation & Operations								
Clifford Bowers (S)	PI	University of Florida	Chemistry	UF Opportunity Seed Fund		P17372	Search for Chiral Spin Wave Resonances in a 2DES	Condensed Matter Physics	1	7	
Dmitri Maslov (S)	C	University of Florida	NA								
John Tokarski (G)	C	University of Florida	Chemistry								
Bjoern Wehinger (P)	PI	University of Geneva, Switzerland	DPMC	University of Geneva		P17371	High pressure susceptibility studies on a quasi-2D metal-organic Heisenbergantiferromagnet	Condensed Matter Physics	1	5.48	
Susan Herringer (P)	C	University of Bern	Department of Chemistry and Biochemistry								
Karl Kraemer (S)	C	University of Bern	Chemistry and Biochemistry								
Mariusz Kubus (P)	C	University of Bern	Department of Chemistry								
Christian Rueegg (S)	C	Paul Scherrer Institute	Laboratory for Neutron Scattering and Imaging								
James Gleeson (S)	PI	Kent State University	Physics	NSF - National Science Foundation	DMR – Division of Materials Research	1307674	P17368	High magnetic field optical studies of complex fluids	Condensed Matter Physics	1	4.7
Antal Jakli (S)	C	Kent State University	Liquid Crystal Institute								
Matthew Murachver (G)	C	Kent State University	Chemical Physics Interdisciplinary Program								
Rony Saha (G)	C	Kent State University	Physics								
Sam Sprunt (S)	C	Kent State University	Physics								
Toshihito Osada (S)	PI	University of Tokyo	Department of Physics in Extreme Conditions	JSPS KAKENHI		JP15K21722	P17365	Quantum Size Effect on Field-Induced Phase Transition in Thin-Film Graphite: Experimental Confirmation of Density	Condensed Matter Physics	1	4.1
Woun Kang (S)	C	Ewha Womans University	Department of Physics								

# Appendix VI – User Proposals

		Participants (Name, Role, Org., Dept.)		Funding Sources (Funding Agency, Division, Award #)			Proposal #	Proposal Title	Discipline	Exp. #	Days Used
Toshihiro Taen (S)	C	University of Tokyo	The Institute for Solid State Physics					Wave Formation			
Kazuhiro Uchida (S)	C	University of Tokyo	Institute for Solid State Physics								
Brad Ramshaw (S)	PI *	Cornell University	Laboratory of Atomic and Solid State Physics	Cornell University			<b>P17359</b>	Determining of the onset of Fermi surface reconstruction in Nd-LSCO via angle-dependent magnetoresistance	Condensed Matter Physics	1	3.71
Nicolas Doiron-Leyraud (S)	C	University of Sherbrooke	Physics								
Paul Goddard (S)	C	University of Warwick	Department of Physics								
Francis Laliberte (G)	C	University of Sherbrooke	Physics								
Anaëlle Legros (G)	C	University of Sherbrooke	Physics								
Louis Taillefer (S)	C	University of Sherbrooke	Physics								
Gang Cao (S)	PI	University of Colorado, Boulder	Department of Physics.	NSF - National Science Foundation	DMR – Division of Materials Research	DMR-1712101	<b>P17358</b>	Probing Spin-Orbit Coupled 5d-Electron Iridates Using High Magnetic Field	Condensed Matter Physics	1	4.94
David Graf (S)	C	National High Magnetic Field Laboratory (NHMFL)	DC Field CMS								
Yifei Ni (G)	C	University of Colorado, Boulder	Physics								
Wenhai Song (P)	C	University of Colorado, Boulder	Department of Physics								
Jasminka Terzic (P)	C	University of Colorado, Boulder	Physics								
Yu Zhang (G)	C	University of Colorado, Boulder	Physics								
Hengdi Zhao (G)	C	University of Colorado, Boulder	Physics								
Hao Zheng (G)	C	University of Colorado, Boulder	Physics								
Elizabeth Green (P)	PI *	Helmholtz-Zentrum Dresden-Rossendorf	Dresden High Magnetic Field Laboratory	Helmholtz-Zentrum Dresden-Rossendorf			<b>P17353</b>	Search for quantum criticality in a variety of heavy Fermion compounds	Condensed Matter Physics	1	7
Cedomir Petrovic (S)	C	Brookhaven National Laboratory	Condensed Matter Physics	Deutsche Forschungsgemeinschaft (DFG)							
Aifeng Wang (P)	C	Brookhaven National Laboratory	Condensed Matter Physics								

# Appendix VI – User Proposals

		Participants (Name, Role, Org., Dept.)		Funding Sources (Funding Agency, Division, Award #)		Proposal #	Proposal Title	Discipline	Exp. #	Days Used
Stephen McGill (S)	PI	National High Magnetic Field Laboratory (NHMFL)	Condensed Matter Science	Princeton University		P17352	Magnetic Field Effects on Ultrafast Photo-induced Spin Dynamics in Organic Nanoparticles for Photovoltaics	Chemistry, Geochemistry	1	2.16
Bryan Kudisch (S)	C	Princeton University	Chemistry							
Margherita Maiuri (P)	C	Princeton University	Chemistry							
Luca Moretti (P)	C	Princeton University	Chemistry							
Greg Scholes (S)	C	Princeton University	Chemistry							
Bernd Halbedel (S)	PI *	Technische Universität Ilmenau	Group for Inorganic-Nonmetallic Materials, Institute for Material Engineering and Institute for Micro- and Nanotechnologies	Technische Universität Ilmenau		P17347	Trapped field bulk magnet system for Lorentz Force Velocimetry	Engineering	1	7
Dmytro Abraimov (S)	C	National High Magnetic Field Laboratory (NHMFL)	The Applied Superconductivity Center							
Jan Jaroszynski (S)	C	National High Magnetic Field Laboratory (NHMFL)	CMS							
Oleksii Vakaliuk (G)	C	Technische Universität Ilmenau	Group for Inorganic-Nonmetallic Materials Institute for Material Engineering and Institute for Micro- and Nanotechnologies							
Frank Werfel (S)	C	Adelwitz Technologiezentrum GmbH	Adelwitz Technologiezentrum GmbH (ATZ)							
Sergei Zvyagin (S)	PI	Helmholtz-Zentrum Dresden-Rossendorf	EPR	German Research Foundation (DFG)		P17345	Spin dynamics and magnetic properties of spin systems with competing magnetic interactions	Condensed Matter Physics	1	5.88
Sang Wook Cheong (S)	C	Rutgers University, New Brunswick	Physics and Astronomy							
David Graf (S)	C	National High Magnetic Field Laboratory (NHMFL)	DC Field CMS							
Marcelo Jaime (S)	C	National High Magnetic Field Laboratory (NHMFL)	Physics							



# Appendix VI – User Proposals

		Participants (Name, Role, Org., Dept.)		Funding Sources (Funding Agency, Division, Award #)			Proposal #	Proposal Title	Discipline	Exp. #	Days Used
Jurek Krzystek (S)	C	National High Magnetic Field Laboratory (NHMFL)	Condensed Matter Science								
Chris Landee (S)	C	Clark University	Department of Physics								
David Mandrus (S)	C	University of Tennessee, Knoxville	Materials Science and Engineering								
Stephen Nagler (S)	C	Oak Ridge National Laboratory									
Shanti Deemyad (S)	PI	University of Utah	Physics and Astronomy	NSF - National Science Foundation	DMR – Division of Materials Research	1351986	<b>P17344</b>	Fermi Surface of Lithium Isotopes	Condensed Matter Physics	1	7
Neil Ashcroft (S)	C	Cornell University	Physics	DOE - Department of Energy	Office of Science	DE-SC-0001057					
Stanimir Bonev (S)	C	Lawrence Livermore National Laboratory	Physics Division								
Sabri Elatresh (P)	C	Cornell University	chemistry								
Roald Hoffmann (S)	C	Cornell University	Dept. of Chemistry and Chemical Biology								
Cassie (Rong) Zhang (G)	C	University of Utah	Physics and Astronomy								
Brian Maple (S)	PI	University of California, San Diego	Inst for Pure & Applied Physical Sciences	DOE - Department of Energy	Office of Science - BES – Basic Energy Sciences	DE-FG02-04ER46105	<b>P17341</b>	Physical properties of the URu <sub>2</sub> Si <sub>2</sub> system with chemical substitution in high magnetic fields	Condensed Matter Physics	1	4.37
Ryan Baumbach (S)	C	National High Magnetic Field Laboratory (NHMFL)	CMS	DOE - Department of Energy	NNSA – National Nuclear Security Administration	DE-NA0002909					
Alexander Breindel (G)	C	University of California, San Diego	Physics								
Marcelo Jaime (S)	C	National High Magnetic Field Laboratory (NHMFL)	Physics								
Trevor Keiber (P)	C	University of California, San Diego	Physics								
Naveen Pouse (G)	C	University of California, San Diego	Physics								

# Appendix VI – User Proposals

Participants (Name, Role, Org., Dept.)		Funding Sources (Funding Agency, Division, Award #)		Proposal #	Proposal Title	Discipline	Exp. #	Days Used			
Sheng Ran (P)	C	University of California, San Diego	Physics								
John Singleton (S)	C	National High Magnetic Field Laboratory (NHMFL)	Physics								
Malte Grosche (S)	PI	University of Cambridge	Cavendish Laboratory	EPSRC of the United Kingdom	<b>P16299</b>	Fermi surface and carrier mass renormalisation in the high pressure metallised Mott insulator NiS <sub>2</sub>	Condensed Matter Physics	1	5.86		
Jordan Baglo (P)	C	University of Cambridge	Cavendish Laboratory								
William Coniglio (S)	C	National High Magnetic Field Laboratory (NHMFL)									
Sven Friedemann (S)	C	University of Bristol	Department of Physics								
Audrey Grockowiak (S)	C	National High Magnetic Field Laboratory (NHMFL)	DC Field/CMS								
Konstantin Semeniuk (G)	C	University of Cambridge	Cavendish Laboratory								
Stan Tozer (S)	C	National High Magnetic Field Laboratory (NHMFL)	Physics								
Anand Bhattacharya (S)	PI	Argonne National Laboratory	Materials Science Division & Center for Nanoscale Materials	DOE - Department of Energy	Office of Science - BES – Basic Energy Sciences	DEAC02-06CH11357	<b>P16295</b>	Determining the superfluid density in the non-adiabatic limit of superconducting SrTiO <sub>3-d</sub>	Condensed Matter Physics	2	14
Terence Bretz-Sullivan (P)	C	Argonne National Laboratory	Materials Science Division	DOE - Department of Energy	Office of Science - BES – Basic Energy Sciences	DE-AC02-06CH11357					
Alexey Suslov (S)	C	National High Magnetic Field Laboratory (NHMFL)	Condensed Matter Science								
Sergey Suchalkin (S)	PI	State University of New York at Stony Brook	Electrical and Computer Engineering	State University of New York at Stony Brook			<b>P16294</b>	Carrier dispersion and nontrivial topological phases in ultra-low bandgap metamorphic InAsSb/InAsSb superlattices	Condensed Matter Physics	1	6
Gregory Belenky (S)	C	State University of New York at Stony Brook	Electrical and Computer Engineering								
Seonghill Moon (G)	C	National High Magnetic Field Laboratory (NHMFL)	Physics								
Dmitry Smirnov (S)	C	National High Magnetic Field Laboratory (NHMFL)	Instrumentation & Operations								

# Appendix VI – User Proposals

Participants (Name, Role, Org., Dept.)		Funding Sources (Funding Agency, Division, Award #)		Proposal #	Proposal Title	Discipline	Exp. #	Days Used			
Laboratory (NHMFL)											
Cory Dean (S)	PI	City College of New York	Physics	NSF - National Science Foundation	DMR – Division of Materials Research	1462383	<b>P16292</b>	Novel phases and exotic states of two-dimensional materials in high magnetic field	Condensed Matter Physics	4	22.37
Shaowen Chen (G)	C	Columbia University	Applied Physics and Applied Mathematics	NSF - National Science Foundation	DMR – Division of Materials Research	DMR-1507788					
Scott Dietrich (P)	C	Columbia University	Physics								
Martin Gustafsson (P)	C	Columbia University	Physics								
Jia Li (P)	C	Columbia University	Physics								
Xiaomeng Liu (G)	C	Harvard University	Physics								
Brad Ramshaw (S)	C	Cornell University	Laboratory of Atomic and Solid State Physics								
Rebeca Ribeiro Palau (P)	C	Columbia University	Physics								
Cheng Tan (G)	C	Columbia University	Electrical Engineering								
Matthew Yankowitz (P)	C	Columbia University	Physics								
Yihang Zeng (G)	C	Columbia University	Physics								
Sara Haravifard (S)	PI	Duke University	Department of Physics	Duke University			<b>P16290</b>	Pressure Tuning the Ground State of a Quasi-One Dimensional Superconductor	Condensed Matter Physics	1	7
David Graf (S)	C	National High Magnetic Field Laboratory (NHMFL)	DC Field CMS								
Toni Helm (P)	C	Max Planck Institute	Physics of Quantum materials								
Stephen Kuhn (P)	C	Duke University	Physics								
Hongcheng Lu (P)	C	Duke University	Physics								
Brodie Popovic (G)	C	Duke University	Physics								
Zhenzhong Shi (P)	C	National High Magnetic Field Laboratory (NHMFL)	CMS, NHMFL								
William Steinhardt (G)	C	Duke University	Physics								
Sara Haravifard (S)	PI	Duke University	Department of Physics	Duke University			<b>P16289</b>	Role of Site Mixing on the Ground State of a spin-1/2	Condensed Matter Physics	1	7

# Appendix VI – User Proposals

Participants (Name, Role, Org., Dept.)		Funding Sources (Funding Agency, Division, Award #)			Proposal #	Proposal Title	Discipline	Exp. #	Days Used	
David Graf (S)	C	National High Magnetic Field Laboratory (NHMFL)	DC Field CMS				Triangular Antiferromagnetic System			
Brodie Popovic (G)	C	Duke University	Physics							
Zhenzhong Shi (P)	C	National High Magnetic Field Laboratory (NHMFL)	CMS, NHMFL							
William Steinhart (G)	C	Duke University	Physics							
Alexander Usoskin (S)	PI *	Bruker HTS GmbH	R&D	NHMFL UCGP - User Collaboration Grants Program	DMR – Division of Materials Research	DMR-1157490, DMR-0923070	<b>P16288</b> High field homogeneity evaluation of new, high performance YBCO coated conductor with double disorder (DD)	Magnets, Materials, Testing, Instrumentation	1	2.9
Dmytro Abraimov (S)	C	National High Magnetic Field Laboratory (NHMFL)	The Applied Superconductivity Center							
Griffin Bradford (O)	C	National High Magnetic Field Laboratory (NHMFL)	Applied Superconductivity Center							
David Larbalestier (S)	C	National High Magnetic Field Laboratory (NHMFL)	ASC							
Mansour Shayegan (S)	PI	Princeton University	Department of Electrical Engineering	NSF - National Science Foundation	DMR – Division of Materials Research	1157490	<b>P16287</b> Probing Exotic Phases of Interacting Electrons in Low-dimensional Systems	Condensed Matter Physics	3	26.27
Hao Deng (G)	C	Princeton University	Electrical Engineering							
Md Shafayat Hossain (G)	C	Princeton University	EE							
Meng Ma (G)	C	Princeton University	Electrical Engineering							
James Hone (S)	PI	Columbia University	Mechanical Engineering	DOE - Department of Energy	Office of Science - BES – Basic Energy Sciences	DE-SC0016703	<b>P16286</b> Studies of Quantum Transport in Two-Dimensional Transition Metal Dichalcogenide Heterostructures	Condensed Matter Physics	1	6.75
Xu Cui (G)	C	Columbia University	Mechanical Engineering							
Cory Dean (S)	C	City College of New York	Physics							
Martin Gustafsson (P)	C	Columbia University	Physics							
Youngduck Kim (P)	C	Columbia University	Mechanical Engineering							
Jia Li (P)	C	Columbia University	Physics							

# Appendix VI – User Proposals

Participants (Name, Role, Org., Dept.)		Funding Sources (Funding Agency, Division, Award #)		Proposal #	Proposal Title	Discipline	Exp. #	Days Used	
Daniel Rhodes (P)	C	Columbia University	Mechanical Engineering						
Rebeca Ribeiro Palau (P)	C	Columbia University	Physics						
En-Min Shih (G)	C	Columbia University	Physics						
Cheng Tan (G)	C	Columbia University	Electrical Engineering						
Louis Taillefer (S)	PI	University of Sherbrooke	Physics	NSERC Canada	<b>P16283</b>	Transport studies of the pseudogap critical point of cuprates	Condensed Matter Physics	1	9.13
Amirreza Ataei (G)	C	University of Sherbrooke	Physics	Gordon and Betty Moore Foundation					
Sven Badoux (P)	C	University of Sherbrooke	Physics						
Clément Collignon (G)	C	University of Sherbrooke	Physics						
Nicolas Doiron-Leyraud (S)	C	University of Sherbrooke	Physics						
Adrien Gourgout (P)	C	University of Sherbrooke	Physics						
Francis Laliberte (G)	C	University of Sherbrooke	Physics						
Maude Lizaire (G)	C	University of Sherbrooke	Physics						
David Graf (S)	PI	National High Magnetic Field Laboratory (NHMFL)	DC Field CMS	NHMFL UCGP - User Collaboration Grants Program	<b>P16282</b>	Study of the Electronic Structures of Doped Dirac Metals and Topological Insulators	Condensed Matter Physics	2	11.19
Luis Balicas (S)	C	National High Magnetic Field Laboratory (NHMFL)	Condensed Matter Experiment						
Ryan Baumbach (S)	C	National High Magnetic Field Laboratory (NHMFL)	CMS						
Kuan-Wen Chen (G)	C	National High Magnetic Field Laboratory (NHMFL)	CMS						
Vesna Mitrovic (S)	PI	Brown University	Physics	Brown University	<b>P16281</b>	Resistively and inductively detected NMR as probe of topological Kondo Insulator SmB6	Condensed Matter Physics	1	7
Rong Cong (G)	C	Brown University	Physics						
Erick Garcia (G)	C	Brown University	Department of Physics						
Wencong Liu (G)	C	Brown University	Physics						
Arneil Reyes (S)	C	National High Magnetic Field Laboratory (NHMFL)	Condensed Matter Science						

# Appendix VI – User Proposals

Participants (Name, Role, Org., Dept.)		Funding Sources (Funding Agency, Division, Award #)			Proposal #	Proposal Title	Discipline	Exp. #	Days Used		
David Larbalestier (S)	PI	National High Magnetic Field Laboratory (NHMFL)	ASC	DOE - Department of Energy	Office of Science - HEP – High Energy Physics	DE-SC0010421	<b>P16280</b>	High Field Transport Properties of Modern Bi-2212 Round Wires	Magnets, Materials, Testing, Instrumentation	1	5.52
Dmytro Abraimov (S)	C	National High Magnetic Field Laboratory (NHMFL)	The Applied Superconductivity Center								
Michael Brown (G)	C	National High Magnetic Field Laboratory (NHMFL)	ASC								
Daniel Davis (G)	C	National High Magnetic Field Laboratory (NHMFL)	ASC								
Jianyi Jiang (S)	C	National High Magnetic Field Laboratory (NHMFL)	ASC								
Yavuz Oz (G)	C	National High Magnetic Field Laboratory (NHMFL)	Applied Superconductivity Center								
Marcelo Jaime (S)	PI	National High Magnetic Field Laboratory (NHMFL)	Physics	No other support (i.e. this experiment is entirely supported by NHMFL users services via its core grant)			<b>P16279</b>	Probing high field magnetoelastic coupling in CeRhIn5	Condensed Matter Physics	1	4.6
Fedor Balakirev (S)	C	National High Magnetic Field Laboratory (NHMFL)	PFF								
Eric Bauer (S)	C	Los Alamos National Laboratory	MST-10								
Priscila Ferrari Silveira Rosa (P)	C	Los Alamos National Laboratory	MPA-CMMS								
Filip Ronning (S)	C	Los Alamos National Laboratory	MPA-CMMS								
Myron Salamon (S)	C	University of Texas, Dallas	Physics								
Mike Sumption (S)	PI	Ohio State University	LASM, MSE	DOE - Department of Energy	Office of Science - HEP – High Energy Physics	DE-SC0013849	<b>P16278</b>	High Field Transport Properties in ternary and Binary APC type Nb3Sn Conductors	Magnets, Materials, Testing, Instrumentation	1	3.3
Fernando Machado (S)	PI	Federal University of Pernambuco	Physics	Fundação de Apoio à Pesquisa de Pernambuco - FACEPE			<b>P16271</b>	Thermal Conductivity Of Yig At High-Applied Magnetic Fields And Low Temperatures	Condensed Matter Physics	1	5.65
Luis Balicas (S)	C	National High Magnetic Field Laboratory (NHMFL)	Condensed Matter Experiment								

# Appendix VI – User Proposals

Participants (Name, Role, Org., Dept.)		Funding Sources (Funding Agency, Division, Award #)			Proposal #	Proposal Title	Discipline	Exp. #	Days Used		
Zahid Hasan (S)	PI *	Princeton University	Physics	DOE - Department of Energy	Office of Science - BES – Basic Energy Sciences	FG-02-05ER46200	<b>P16269</b>	Evidence for magnetic field-induced phase-transitions in type I Weyl semi-metals upon approaching the quantum limit: phase-diagram and nature of the field-induced phases	Condensed Matter Physics	1	5.28
Luis Balicas (S)	C	National High Magnetic Field Laboratory (NHMFL)	Condensed Matter Experiment								
Fumitake Kametani (P)	C	National High Magnetic Field Laboratory (NHMFL)	ASC								
Rico Schoenemann (G)	C	Helmholtz-Zentrum Dresden-Rossendorf	Dresden High Magnetic Field Laboratory								
Dmitry Smirnov (S)	C	National High Magnetic Field Laboratory (NHMFL)	Instrumentation & Operations								
Yejun Feng (S)	PI	Okinawa Institute of Science and Technology	Electronic and Quantum Magnetism Unit	DOE - Department of Energy	Office of Science - BES – Basic Energy Sciences	DE-SC0014866	<b>P16267</b>	Probing the insulating nature of antiferromagnetic 5d pyrochlore	Condensed Matter Physics	1	6
Tom Rosenbaum (S)	C	University of Chicago	Physics								
Daniel Silevitch (S)	C	University of Chicago	Physics, Math, and Astronomy								
Alexey Suslov (S)	C	National High Magnetic Field Laboratory (NHMFL)	Condensed Matter Science								
Yishu Wang (G)	C	California Institute of Technology	Physics								
Igor Kuskovsky (S)	PI	Queens College of CUNY	Physics	Queens College (PSC-CUNY)			<b>P16264</b>	Magneto-optics of Light Hole Type-II Excitons in Stacked Submonolayer Quantum Dots	Condensed Matter Physics	1	7
Vasilios Deligiannakis (G)	C	The City College of New York	Physics								
Tony Le (G)	C	Queens College of CUNY	Physics								
Dmitry Smirnov (S)	C	National High Magnetic Field Laboratory (NHMFL)	Instrumentation & Operations								
Maria Tamargo (S)	C	The City College of New York	Chemistry								
Rong Wu (G)	C	Queens College of CUNY	Physics								
Anup Patel (P)	PI *	University of Cambridge	Materials Science and Metallurgy	UK EPSRC			<b>P16260</b>	Determining the trapped field limits of stacks of high temperature superconducting tape	Engineering	1	7

# Appendix VI – User Proposals

		Participants (Name, Role, Org., Dept.)		Funding Sources (Funding Agency, Division, Award #)			Proposal #	Proposal Title	Discipline	Exp. #	Days Used
Cheol Eui Lee (S)	PI *	Korea University	Department of Physics	National Research Foundation of Korea			P16259	Three-dimensional quantum Hall plateaus in HOPG with disorder in the quantum limits	Condensed Matter Physics	1	7
Do Wan Kim (G)	C	Korea University	Department of Physics								
Jin Jung Kweon (P)	C	National High Magnetic Field Laboratory (NHMFL)	CIMAR								
Kyu Won Lee (P)	C	Korea University	Department of Physics								
Joseph Checkelsky (S)	PI	Massachusetts Institute of Technology	Physics	MIT			P16258	High Field Studies of Magnetic Weyl Semimetals	Condensed Matter Physics	1	5.81
Aravind Devarakonda (G)	C	Massachusetts Institute of Technology	Physics								
Takehito Suzuki (P)	C	Massachusetts Institute of Technology	Department of Physics								
Linda Ye (G)	C	Massachusetts Institute of Technology	Physics								
Junbo Zhu (G)	C	Massachusetts Institute of Technology	Physics								
Rongying Jin (S)	PI *	Louisiana State University	Physics and Astronomy	NSF - National Science Foundation	DMR – Division of Materials Research	NSF-DMR-150426					
Silu Huang (G)	C	Louisiana State University	Physics								
Rongying Jin (S)	C	Louisiana State University	Department of Physics and Astronomy								
Neil Harrison (S)	PI	National High Magnetic Field Laboratory (NHMFL)	Physics	DOE - Department of Energy	Office of Science - BES – Basic Energy Sciences	DOE BES	P16256	Strong versus weak pairing in high-T <sub>c</sub> superconductors	Condensed Matter Physics	1	4.4
Mun Chan (P)	C	National High Magnetic Field Laboratory (NHMFL)	Pulsed field Facility								
Alexander Davies (G)	C	University of Cambridge	Physics								
Mate Hartstein (G)	C	University of Cambridge	Physics								



# Appendix VI – User Proposals

Participants (Name, Role, Org., Dept.)		Funding Sources (Funding Agency, Division, Award #)			Proposal #	Proposal Title	Discipline	Exp. #	Days Used		
Yu Hsu (G)	C	University of Cambridge	Physics								
Péter Juhász (U)	C	University of Cambridge	Department of Physics								
Bernhard Keimer (S)	C	Max Planck Institute	Solid State Spectroscopy								
Aida Sanchez Ricol (U)	C	University of Cambridge	Physics Department								
Suchitra Sebastian (S)	C	University of Cambridge	Physics								
Rui-Rui Du (S)	PI	Rice University	Physics and Astronomy	NSF - National Science Foundation	DMR – Division of Materials Research	DMR1508644	<b>P16255</b>	High Magnetic Field Thermoelectric Measurements in a Half-Filled Lowest Landau Level	Condensed Matter Physics	3	21.25
Tingxin Li (P)	C	Rice University	Phys & Astro	The Robert A. Welch Foundation							
Xiaoxue Liu (G)	C	Peking University	Physics department								
Tzu-Ming Lu (S)	C	Sandia National Laboratories									
Jie Zhang (G)	C	Rice University	Phys & Astro								
Po Zhang (G)	C	Peking University	International Center for Quantum Materials								
Xiaoyan Shi (S)	PI *	University of Texas, Dallas	Physics	No other support (i.e. this experiment is entirely supported by NHMFL users services via its core grant)			<b>P16252</b>	Transport anomalies of high-mobility atomically thin semiconductors	Condensed Matter Physics	1	5.26
Liheng An (G)	C	Hong Kong University of Science and Technology	Center for Quantum materials								
Tianyi Han (G)	C	Hong Kong University of Science and Technology	Center for Quantum materials								
Jiangxiazi Lin (G)	C	Hong Kong University of Science and Technology	Center for Quantum materials								
Gen Long (G)	C	Hong Kong University of Science and Technology	Center for Quantum materials								

# Appendix VI – User Proposals

Participants (Name, Role, Org., Dept.)		Funding Sources (Funding Agency, Division, Award #)			Proposal #	Proposal Title	Discipline	Exp. #	Days Used
Ning Wang (S)	C	Hong Kong University of Science and Technology	Physics, and Center for Quantum materials						
Xurui Zhang (G)	C	University of Texas, Dallas	Physics						
Kee Hoon Kim (S)	PI	Seoul National University	School of Physics	National Creative Research Initiative in South Korea					
Dilip Bhoi (P)	C	Seoul National University	Department of Physics and Astronomy						
Chanhee Kim (G)	C	Seoul National University	physics and astronomy						
Keizo Murata (S)	C	Osaka City University	Department of Physics, Graduate School of Science						
Woohyun Nam (G)	C	Seoul National University	Department of Physics and Astronomy						
Yeahan Sur (G)	C	Seoul National University	Department of Physics and Astronomy						
Philip Kim (S)	PI	Harvard University	Department of Physics	Army Research Office (ARO)	US Government Lab				
Kristiaan De Greve (P)	C	Harvard University	Physics	NSF - National Science Foundation	1542807				
Katie Huang (G)	C	Harvard University	Physics	Gordon and Betty Moore Foundation					
Luis Jauregui (P)	C	Harvard University	College of Science	DOE - Department of Energy	Office of Science - BES – Basic Energy Sciences	DE-SC0012260			
Andrew Joe (G)	C	Harvard University	Physics	NSF - National Science Foundation	Other	NSF EFMA-1542807			
Jia Li (P)	C	Columbia University	Physics	DOD - Department of Defense (incl. US AirForce, US Army, US Navy)	U.S. Army				
Xiaomeng Liu (G)	C	Harvard University	Physics						
Zhengguang Lu (G)	C	National High Magnetic Field Laboratory (NHMFL)	Physics						

# Appendix VI – User Proposals

Participants (Name, Role, Org., Dept.)		Funding Sources (Funding Agency, Division, Award #)		Proposal #	Proposal Title	Discipline	Exp. #	Days Used		
Kateryna Pistunova (U)	C	Harvard University	Physics							
Giovanni Scuri (G)	C	Harvard University	Physics							
Andrey Sushko (G)	C	Harvard University	Physics							
You Zhou (P)	C	Harvard University	Department of Physics							
Taichi Terashima (S)	PI	National Institute for Materials Science	Nano-quantum Transport Group	NIMS, Japan	<b>P16248</b>	Fermi surface studies of iron-based superconductors and other exotic materials	Condensed Matter Physics	1	5.49	
David Graf (S)	C	National High Magnetic Field Laboratory (NHMFL)	DC Field CMS							
Hishiro Hirose (P)	C	National Institute for Materials Science	Nano-quantum Transport Group							
Woun Kang (S)	C	Ewha Womans University	Department of Physics							
Naoki Kikugawa (S)	C	National Institute for Materials Science	Superconducting Properties Unit							
Dmitry Smirnov (S)	PI	National High Magnetic Field Laboratory (NHMFL)	Instrumentation & Operations	DOE - Department of Energy	Office of Science - BES – Basic Energy Sciences	<b>P16234</b>	Electrical and magnetic field control of optical processes in mono- and few-layer transition metal dichalcogenides	Condensed Matter Physics	1	14
James Hone (S)	C	Columbia University	Mechanical Engineering							
Luis Jauregui (P)	C	Harvard University	College of Science							
Zhigang Jiang (S)	C	Georgia Institute of Technology	School of Physics							
Andrew Joe (G)	C	Harvard University	Physics							
Kaifei Kang (G)	C	Pennsylvania State University	Physics							
Philip Kim (S)	C	Harvard University	Department of Physics							
Zhengguang Lu (G)	C	National High Magnetic Field Laboratory (NHMFL)	Physics							
Kin Fai Mak (S)	C	Pennsylvania State University	Physics							
Seonghill Moon (G)	C	National High Magnetic Field Laboratory (NHMFL)	Physics							
Kateryna Pistunova (U)	C	Harvard University	Physics							

# Appendix VI – User Proposals

		Participants (Name, Role, Org., Dept.)		Funding Sources (Funding Agency, Division, Award #)			Proposal #	Proposal Title	Discipline	Exp. #	Days Used
Daniel Rhodes (P)	C	Columbia University	Mechanical Engineering								
Egon Sohn (G)	C	Pennsylvania State University	Department of Physics								
Zefang Wang (G)	C	Pennsylvania State University	Physics								
Tony Heinz (S)	PI	Stanford University	Department of Physics	NSF - National Science Foundation	DMR – Division of Materials Research	1420634	<b>P16139</b>	Magneto-Optical Study of Atomically Thin Transition Metal Dichalcogenide Crystals	Condensed Matter Physics	1	14
Eric Yue Ma (P)	C	Stanford University	Applied Physics								
Dmitry Smirnov (S)	C	National High Magnetic Field Laboratory (NHMFL)	Instrumentation & Operations								
Xiaoxiao Zhang (G)	C	Columbia University	Physics								
Janice Musfeldt (S)	PI	University of Tennessee, Knoxville	Department of Chemistry	DOE - Department of Energy	Office of Science - BES – Basic Energy Sciences	DE-FG02-01ER45885	<b>P16137</b>	High field spectroscopy of materials	Chemistry, Geochemistry	1	6.15
Shiyu Fan (G)	C	University of Tennessee, Knoxville	Physics								
Stephen McGill (S)	C	National High Magnetic Field Laboratory (NHMFL)	Condensed Matter Science								
Kevin Smith (G)	C	University of Tennessee, Knoxville	Chemistry								
Bo-Kuai Lai (S)	PI *	Lake Shore Cryotronics	Sensor Development	Lake Shore Cryotronics			<b>P16121</b>	High Field Investigation of Hall Sensors	Engineering	1	7
Scott Hannahs (S)	C	National High Magnetic Field Laboratory (NHMFL)	Instrumentation								
Hung-I Kuo (S)	C	Lake Shore Cryotronics	Product development								
Tim Murphy (S)	C	National High Magnetic Field Laboratory (NHMFL)	Operations								
Ju-Hyun Park (S)	C	National High Magnetic Field Laboratory (NHMFL)	Instrumentation & Operations, User Support								
Audrey Grockowiak (S)	PI *	National High Magnetic Field Laboratory (NHMFL)	DC Field/CMS	DOE - Department of Energy	NNSA – National Nuclear Security	DE-NA0001979	<b>P16109</b>	Simultaneous high pressure magnetostriction and magnetic susceptibility study of the SCBO	Condensed Matter Physics	2	11.87

# Appendix VI – User Proposals

Participants (Name, Role, Org., Dept.)		Funding Sources (Funding Agency, Division, Award #)			Proposal #	Proposal Title	Discipline	Exp. #	Days Used		
William Coniglio (S)	C	National High Magnetic Field Laboratory (NHMFL)				Administration	compound				
Christian Rueegg (S)	C	Paul Scherrer Institute	Laboratory for Neutron Scattering and Imaging								
Stan Tozer (S)	C	National High Magnetic Field Laboratory (NHMFL)	Physics								
Bjoern Wehinger (P)	C	University of Geneva, Switzerland	DPMC								
Dmitry Smirnov (S)	PI	National High Magnetic Field Laboratory (NHMFL)	Instrumentation & Operations	DOE - Department of Energy	Office of Science - BES – Basic Energy Sciences	DE-FG02-07ER46451	<b>P16108</b>	Out-of-equilibrium magneto-transport of the surface state in 3D topological insulators	Condensed Matter Physics	3	21
Yong Chen (S)	C	Purdue University	Physics								
Zhigang Jiang (S)	C	Georgia Institute of Technology	School of Physics								
Seongphill Moon (G)	C	National High Magnetic Field Laboratory (NHMFL)	Physics								
Lei Wang (G)	C	Columbia University	Mechanical Engineering								
David Graf (S)	PI	National High Magnetic Field Laboratory (NHMFL)	DC Field CMS	NHMFL UCGP - User Collaboration Grants Program			<b>P16107</b>	Two-axis rotation for DC magnetic fields	Condensed Matter Physics	1	7
Lloyd Engel (S)	PI	National High Magnetic Field Laboratory (NHMFL)	CMS	DOE - Department of Energy	Office of Science - BES – Basic Energy Sciences	DE-FG02-05ER46212	<b>P16106</b>	Microwave spectroscopy of encapsulated graphene in high magnetic field	Condensed Matter Physics	2	17
Jeremy Curtis (G)	C	University of Alabama, Birmingham	Physics								
Cory Dean (S)	C	City College of New York	Physics								
Scott Dietrich (P)	C	Columbia University	Physics								
Matthew Freeman (G)	C	National High Magnetic Field Laboratory (NHMFL)	Condensed Matter Science								
Natalia Drichko (S)	PI *	Johns Hopkins University	Physics and Astronomy	DOE - Department of Energy	Office of Science - BES – Basic Energy Sciences	DE-FG02-08ER46544	<b>P16105</b>	Magneto-electric effect in quasi-2D organic conductors	Condensed Matter Physics	1	7

# Appendix VI – User Proposals

		Participants (Name, Role, Org., Dept.)		Funding Sources (Funding Agency, Division, Award #)			Proposal #	Proposal Title	Discipline	Exp. #	Days Used
Nora Hassan (G)	C	Johns Hopkins University	Physics and Astronomy								
Dmitry Smirnov (S)	C	National High Magnetic Field Laboratory (NHMFL)	Instrumentation & Operations								
Komalavalli Thirunavukkuarasu (S)	C	National High Magnetic Field Laboratory (NHMFL)	EMR								
Cedomir Petrovic (S)	PI	Brookhaven National Laboratory	Condensed Matter Physics	DOE - Department of Energy	Office of Science - BES – Basic Energy Sciences	DE-SC0012704	<b>P16104</b>	Quantum oscillation study of type-2 Weyl semimetals	Condensed Matter Physics	1	7
David Graf (S)	C	National High Magnetic Field Laboratory (NHMFL)	DC Field CMS								
Yu Liu (P)	C	Brookhaven National Laboratory	Condensed Matter Physics								
Aifeng Wang (P)	C	Brookhaven National Laboratory	Condensed Matter Physics								
Sergei Zherlitsyn (S)	PI *	Helmholtz-Zentrum Dresden-Rossendorf	Dresden High Magnetic Field Laboratory (HLD-EMFL)	Helmholtz-Zentrum Dresden-Rossendorf			<b>P16103</b>	Exploration of high field induced exotic phases in low dimensional and frustrated magnets.	Condensed Matter Physics	2	8.03
Joachim Deisenhofer (S)	C	University of Augsburg	Institute of Physics	German Research Foundation (DFG)							
Marcelo Jaime (S)	C	National High Magnetic Field Laboratory (NHMFL)	Physics								
Yoshimitsu Kohama (S)	C	University of Tokyo	Institute for Solid State Physics (ISSP)								
Bella Lake (S)	C	Helmholtz-Zentrum Berlin	EM-AQM								
Alois Loidl (S)	C	University of Augsburg	Center for Electronic Correlations and Magnetism								
Toshihiro Nomura (P)	C	Helmholtz-Zentrum Dresden-Rossendorf	HLD								
Diana Quintero Castro (P)	C	Helmholtz-Zentrum Berlin	Department Methods for Characterization of Transport Phenomena in Energy Materials								

# Appendix VI – User Proposals

Participants (Name, Role, Org., Dept.)		Funding Sources (Funding Agency, Division, Award #)			Proposal #	Proposal Title	Discipline	Exp. #	Days Used		
Yurii Skourski (S)	C	Helmholtz-Zentrum Dresden-Rossendorf	Dresden High Magnetic Field Laboratory (HLD- EMFL)								
Vladimir Tsurkan (S)	C	Augsburg University	Experimental Physics 5								
Zhe Wang (P)	C	University of Augsburg	Experimental Physics V, Institute of Physics								
Vesna Mitrovic (S)	PI	Brown University	Physics	NSF - National Science Foundation	DMR – Division of Materials Research	DMR- 1608760	<b>P16102</b>	Microscopic Investigation of Mott Insulators with Strong Spin-Orbit Coupling	Condensed Matter Physics	1	4.33
Rong Cong (G)	C	Brown University	Physics								
Erick Garcia (G)	C	Brown University	Department of Physics								
Wencong Liu (G)	C	Brown University	Physics								
Arneil Reyes (S)	C	National High Magnetic Field Laboratory (NHMFL)	Condensed Matter Science								
Rongying Jin (S)	PI	Louisiana State University	Department of Physics and Astronomy	DOE - Department of Energy	Office of Science - BES – Basic Energy Sciences	DE- SC0012432	<b>P16101</b>	Unusual Magnetic Field Effect on the Electrical Transport of Cr <sub>1.23</sub> Te <sub>2</sub> single crystals	Condensed Matter Physics	1	5.3
Guixin Cao (P)	C	Louisiana State University	Physics and Astronomy								
Silu Huang (G)	C	Louisiana State University	Physics								
Rongying Jin (S)	C	Louisiana State University	Department of Physics and Astronomy								
Abhay Pasupathy (S)	PI *	Columbia University	Physics	NSF - National Science Foundation	DMR – Division of Materials Research	1420634	<b>P16099</b>	Probing the interface of a Fractional Quantum Hall system and a Superconductor at high magnetic fields	Condensed Matter Physics	3	18.73
Avishai Benyamini (P)	C	Columbia University	Mechanical Engineering								
Evan Telford (G)	C	Columbia University	Physics								
Da Wang (G)	C	Columbia University	Physics								
Yihang Zeng (G)	C	Columbia University	Physics								

# Appendix VI – User Proposals

		Participants (Name, Role, Org., Dept.)		Funding Sources (Funding Agency, Division, Award #)			Proposal #	Proposal Title	Discipline	Exp. #	Days Used
Andrey Podlesnyak (S)	PI *	Oak Ridge National Laboratory	Neutron Sciences Directorate	No other support (i.e. this experiment is entirely supported by NHMFL users services via its core grant)			P16097	Magnetic phase diagram of Tb3Ni	Condensed Matter Physics	1	7
Alexey Suslov (S)	C	National High Magnetic Field Laboratory (NHMFL)	Condensed Matter Science								
Liusuo Wu (P)	C	Oak Ridge National Laboratory	Quantum Condensed Matter Division								
Debdeep Jena (S)	PI *	Cornell University	ECE	NSF - National Science Foundation	DMR – Division of Materials Research	1120296	P16094	Understanding Pairing in Nb2N: A new Epitaxial Superconductor	Condensed Matter Physics	1	5.15
Scott Katzer (S)	C	U.S. Naval Research Laboratory									
Guru Khalsa (P)	C	Cornell University	Applied Physics and Material Science								
David Meyer (S)	C	Navy Research Lab	Electronics Science and Technology Division								
Alexey Suslov (S)	C	National High Magnetic Field Laboratory (NHMFL)	Condensed Matter Science								
Suresh Vishwanath (G)	C	Cornell University	ECE								
Huili Xing (S)	C	Cornell University	ECE								
Rusen Yan (P)	C	Cornell University	Electrical and Computer Engineering								
Vikram Deshpande (S)	PI *	University of Utah	Physics & Astronomy	University of Utah			P16093	Search for Interaction Effects in Dual-Gated Topological Insulators in the Quantum Hall Regime	Condensed Matter Physics	1	5.77
Su Kong Chong (G)	C	University of Utah	Physics & Astronomy								
Taylor Sparks (S)	C	University of Utah	Materials Science & Engineering								
Jiang Wei (S)	PI *	Tulane University	Physics and Engineering Physics	DOE - Department of Energy	Office of Science - BES – Basic Energy Sciences	DE-SC0014208	P16092	Probing 1D electronic structure of van-der-Waalsly-bonded semiconducting nanowire	Condensed Matter Physics	1	4.53
Abin Joshy (G)	C	Tulane University	Physics and Engineering Physics								
Xue Liu (G)	C	Tulane University	Physics and Engineering Physics								



# Appendix VI – User Proposals

	Participants (Name, Role, Org., Dept.)		Funding Sources (Funding Agency, Division, Award #)				Proposal #	Proposal Title	Discipline	Exp. #	Days Used
Chunlei Yue (G)	C	Tulane University	Physics and Engineering Physics								
Irina Drichko (S)	PI	Ioffe Physical-Technical Institute of the Russian Academy of Sciences	Physics of Semiconductors and Dielectrics	Russian Foundation for Basic Research			<b>P16087</b>	High-frequency magnetotransport in high-mobility n-AlGaAs/GaAs/AlGaAs heterostructures with wide quantum well near the filling factor with even denominators, 1/2 and others: Acoustic studies	Condensed Matter Physics	2	14
Dobromir Kamburov (G)	C	Princeton University	ELE	Presidium of the Russian Academy of Sciences							
Loren Pfeiffer (S)	C	Princeton University	Electrical Engineering								
Ivan Smirnov (S)	C	Ioffe Physical-Technical Institute of the Russian Academy of Sciences	Physics of Semiconductors and Dielectrics								
Alexey Suslov (S)	C	National High Magnetic Field Laboratory (NHMFL)	Condensed Matter Science								
Ken West (S)	C	Princeton University	Princeton Institute for the Science and Technology of Materials								
Johnpierre Paglione (S)	PI	University of Maryland, College Park	Center for Nanophysics and Advanced Materials, Department of Physics	DOD - Department of Defense	U.S. Air Force	FA9550-14-1-0332	<b>P16084</b>	Fermi Surface Study by Quantum Oscillations in Transition Metal Phosphides	Condensed Matter Physics	1	0.47
Daniel Campbell (G)	C	University of Maryland, College Park	Physics	NSF - National Science Foundation	DMR – Division of Materials Research	DMR1610349					
David Graf (S)	C	National High Magnetic Field Laboratory (NHMFL)	DC Field CMS								
Kefeng Wang (P)	C	University of Maryland, College Park	Department of Physics								
Zhigang Jiang (S)	PI	Georgia Institute of Technology	School of Physics	DOE - Department of Energy	Office of Science - BES – Basic Energy Sciences	DE-FG02-07ER46451	<b>P16079</b>	Magneto-infrared Spectroscopy Study of Emerging Topological Materials with Layered Structures	Condensed Matter Physics	4	26.63
Yuxuan Jiang (G)	C	Georgia Institute of Technology	School of Physics								

# Appendix VI – User Proposals

Participants (Name, Role, Org., Dept.)		Funding Sources (Funding Agency, Division, Award #)			Proposal #	Proposal Title	Discipline	Exp. #	Days Used		
Dmitry Smirnov (S)	C	National High Magnetic Field Laboratory (NHMFL)	Instrumentation & Operations								
Cedomir Petrovic (S)	PI	Brookhaven National Laboratory	Condensed Matter Physics	DOE - Department of Energy	Office of Science - BES – Basic Energy Sciences	DE-SC0012704	<b>P16075</b>	Quantum Oscillation Study of Layered Dirac Materials	Condensed Matter Physics	1	4.56
David Graf (S)	C	National High Magnetic Field Laboratory (NHMFL)	DC Field CMS								
Yu Liu (P)	C	Brookhaven National Laboratory	Condensed Matter Physics								
Aifeng Wang (P)	C	Brookhaven National Laboratory	Condensed Matter Physics								
Chun Ning (Jeanie) Lau (S)	PI	University of California, Riverside	Department of Physics and Astronomy	DOE - Department of Energy	Office of Science - BES – Basic Energy Sciences		<b>P16071</b>	Symmetry-broken Quantum Hall States and Phase Diagrams in 2D Materials	Condensed Matter Physics	6	43.63
Shi Che (G)	C	University of California, Riverside	Physics								
Ruoyu Chen (P)	C	Ohio State University	Physics								
Emilio Codecido (G)	C	Ohio State University	Physics								
Dmitry Shcherbakov (G)	C	Ohio State University	Physics								
Dmitry Smirnov (S)	C	National High Magnetic Field Laboratory (NHMFL)	Instrumentation & Operations								
Petr Stepanov (G)	C	University of California, Riverside	Physics								
Son Tran (G)	C	University of California, Riverside	Physics								
Jiawei Yang (G)	C	University of California, Riverside	Physics								
N. Phuan Ong (S)	PI	Princeton University	Physics	DOD - Department of Defense	U.S. Army	ARO W911NF-12-1-0461	<b>P16070</b>	High-field thermos power of the $\nu=1/2$ state in ultra-thin GaAs devices	Condensed Matter Physics	1	6.08
Tong Gao (G)	C	Princeton University	Physics	DOD - Department of Defense	U.S. Army	ARO W911NF-11-1-0379					
Sihang Liang (G)	C	Princeton University	Physics	Other - Betty & Gordon Moore foundation							
Jingjing Lin (G)	C	Princeton University	Physics								
Wudi Wang (G)	C	Princeton University	Physics								

# Appendix VI – User Proposals

Participants (Name, Role, Org., Dept.)		Funding Sources (Funding Agency, Division, Award #)			Proposal #	Proposal Title	Discipline	Exp. #	Days Used		
Kate Ross (S)	PI *	Colorado State University	Physics	Colorado State University	P16040	Out of equilibrium effects in a quantum magnet	Condensed Matter Physics	1	2.39		
Timothy Reeder (U)	C	Colorado State University	Physics								
Neil Harrison (S)	PI	National High Magnetic Field Laboratory (NHMFL)	Physics	DOE - Department of Energy	Office of Science - BES – Basic Energy Sciences	LANL F100	P16038	Investigating the Nature of the Pairing in High-Tc Superconductors	Condensed Matter Physics	1	5.66
Sofia Coronel (G)	C	University of Cambridge	Physics								
Alexander Davies (G)	C	University of Cambridge	Physics								
Mate Hartstein (G)	C	University of Cambridge	Physics								
Yu Hsu (G)	C	University of Cambridge	Physics								
Hsu Liu (G)	C	University of Cambridge	Physics								
Gil Lonzarich (S)	C	University of Cambridge	Physics								
Suchitra Sebastian (S)	C	University of Cambridge	Physics								
Satoru Nakatsuji (S)	PI	University of Tokyo	Institute for Solid State Physics	Japanese Society of Promotion of Science			P16028	Measurement of Quantum Oscillations near the Quantum Limit in Mn <sub>3</sub> Sn; a Candidate for a Magnetic Metallic Weyl Fermion system	Condensed Matter Physics	1	4.2
Luis Balicas (S)	C	National High Magnetic Field Laboratory (NHMFL)	Condensed Matter Experiment								
Jonathan Betts (S)	C	National High Magnetic Field Laboratory (NHMFL)	NHMFL-PFF								
Neil Harrison (S)	C	National High Magnetic Field Laboratory (NHMFL)	Physics								
Yoshimitsu Kohama (S)	C	University of Tokyo	Institute for Solid State Physics (ISSP)								
Ross McDonald (S)	C	National High Magnetic Field Laboratory (NHMFL)	Physics								
Rico Schoenemann (G)	C	Helmholtz-Zentrum Dresden-Rossendorf	Dresden High Magnetic Field Laboratory								
Yasuyuki Shimura (P)	C	University of Tokyo	Institute for Solid State Physics								
Venkat Selvamanickam (S)	PI	University of Houston	Mechanical Engineering	University of Houston			P16004	lc characterization of >4 micron thick REBa <sub>2</sub> Cu <sub>3</sub> O <sub>x</sub>	Magnets, Materials,	1	5.59

# Appendix VI – User Proposals

	Participants (Name, Role, Org., Dept.)			Funding Sources (Funding Agency, Division, Award #)			Proposal #	Proposal Title	Discipline	Exp. #	Days Used
Aixia Xu (S)	C	University of Houston	Texas Superconductivity Center at the University of Houston					coated conductors at 4 K and very high magnetic fields	Testing, Instrumentation		
Yong Chen (S)	PI	Purdue University	Physics	NSF - National Science Foundation	DMR – Division of Materials Research	1410942	<b>P16002</b>	Quantum Transport in thin 3D Topological Insulators	Condensed Matter Physics	1	5.59
Ireneusz Miotkowski (S)	C	Purdue University	Physics Department								
Yang Xu (G)	C	Purdue University	Physics								
William Coniglio (S)	PI *	National High Magnetic Field Laboratory (NHMFL)		DOE - Department of Energy	NNSA – National Nuclear Security Administration	NNSA SSAA DE-NA0001979	<b>P16001</b>	Macroscopic and microscopic investigations of quantum matter with field and pressure	Condensed Matter Physics	2	10.26
Nicolas Doiron-Leyraud (S)	C	University of Sherbrooke	Physics								
Takao Ebihara (S)	C	Shizuoka University	Physics								
David Graf (S)	C	National High Magnetic Field Laboratory (NHMFL)	DC Field CMS								
Audrey Grockowiak (S)	C	National High Magnetic Field Laboratory (NHMFL)	DC Field/CMS								
Tim Murphy (S)	C	National High Magnetic Field Laboratory (NHMFL)	Operations								
Ju-Hyun Park (S)	C	National High Magnetic Field Laboratory (NHMFL)	Instrumentation & Operations, User Support								
Louis Taillefer (S)	C	University of Sherbrooke	Physics								
Stan Tozer (S)	C	National High Magnetic Field Laboratory (NHMFL)	Physics								
Nuh Gedik (S)	PI	Massachusetts Institute of Technology	Physics	DOD - Department of Defense	U.S. Army		<b>P15999</b>	Magnetic field induced Kitaev quantum spin liquid in a-RuCl <sub>3</sub>	Condensed Matter Physics	1	14
Zhanybek Alpichshev (P)	C	Massachusetts Institute of Technology	Physics								
Gang Cao (S)	C	University of Colorado, Boulder	Department of Physics.								

# Appendix VI – User Proposals

		Participants (Name, Role, Org., Dept.)		Funding Sources (Funding Agency, Division, Award #)			Proposal #	Proposal Title	Discipline	Exp. #	Days Used
Kwang Yong Choi (S)	C	Chung Ang University	Department of Physics								
Emre Ergecen (G)	C	Massachusetts Institute of Technology	Electrical Engineering & Computer Science								
Stephen McGill (S)	C	National High Magnetic Field Laboratory (NHMFL)	Condensed Matter Science								
Zhiguo Chen (S)	PI *	Institute of Physics, Chinese Academy of Sciences	Key Laboratory of Extreme Conditions Physics	Hundred Talents Program of Chinese Academy of Sciences			P15997	Magneto-optical Spectroscopy of Three-dimensional topological materials	Condensed Matter Physics	4	27.05
Jianlin Luo (S)	C	Institute of Physics, Chinese Academy of Sciences	Key Laboratory of Extreme Conditions Physics								
Nanlin Wang (S)	C	Peking University	International Center for Quantum Materials								
Stephen McGill (S)	PI	National High Magnetic Field Laboratory (NHMFL)	Condensed Matter Science	NSF - National Science Foundation	DMR – Division of Materials Research	DMR-1229217	P15996	Optical Spectroscopy of Novel Two-Dimensional Materials	Condensed Matter Physics	2	17
Luis Balicas (S)	C	National High Magnetic Field Laboratory (NHMFL)	Condensed Matter Experiment								
Carlos Garcia (G)	C	Florida State University (FSU)	Physics								
Joshua Holleman (G)	C	Florida State University (FSU)	Physics								
Efstratios Manousakis (S)	C	Florida State University (FSU)	Physics								
Sara Haravifard (S)	PI	Duke University	Department of Physics	Duke University			P15993	Pressure-Induced Bosonic States in the Spin Dimer System SrCu <sub>2</sub> (BO <sub>3</sub> ) <sub>2</sub> at Low Fields	Condensed Matter Physics	2	9
David Graf (S)	C	National High Magnetic Field Laboratory (NHMFL)	DC Field CMS	Duke University Endowment, Ralph E. Powe Junior Faculty Enhancement Award							
Hongcheng Lu (P)	C	Duke University	Physics								
Brodie Popovic (G)	C	Duke University	Physics								
Zhenzhong Shi (P)	C	National High Magnetic Field Laboratory (NHMFL)	CMS, NHMFL								
William Steinhardt (G)	C	Duke University	Physics								

# Appendix VI – User Proposals

Participants (Name, Role, Org., Dept.)		Funding Sources (Funding Agency, Division, Award #)			Proposal #	Proposal Title	Discipline	Exp. #	Days Used		
Yuanbo Zhang (S)	PI	Fudan University	Physics	National Science Foundation of China		P15988	Quantum transport in black phosphorus and other novel two-dimensional materials	Condensed Matter Physics	1	5.01	
Shuaifei Guo (G)	C	Fudan University	Physics Department								
Fangyuan Yang (G)	C	Fudan University	Dept. of Physics								
Zuocheng Zhang (P)	C	Fudan University	Physics								
Luis Balicas (S)	PI	National High Magnetic Field Laboratory (NHMFL)	Condensed Matter Experiment	DOE - Department of Energy	Office of Science - BES – Basic Energy Sciences	DE-SC0002613	P15986	Fermiology in geometrically frustrated heavy fermions	Condensed Matter Physics	2	19
Emilia Morosan (S)	C	Rice University	Physics and Astronomy								
Daniel Rhodes (P)	C	Columbia University	Mechanical Engineering								
Rico Schoenemann (G)	C	Helmholtz-Zentrum Dresden-Rossendorf	Dresden High Magnetic Field Laboratory								
Jin Hu (S)	PI	Tulane University	Physics	DOE - Department of Energy	Office of Science - BES – Basic Energy Sciences	DE-SC0014208	P14984	Exotic High Field Quantum Phenomena of Nodal-line Fermions	Condensed Matter Physics	1	5.92
David Graf (S)	C	National High Magnetic Field Laboratory (NHMFL)	DC Field CMS								
Marcelo Jaime (S)	C	National High Magnetic Field Laboratory (NHMFL)	Physics								
Jinyu Liu (G)	C	Tulane University	Department of Physics and Engineering Physics								
Xue Liu (G)	C	Tulane University	Physics and Engineering Physics								
Zhiqiang Mao (S)	C	Tulane University	Physics Department								
Dagmar Weickert (S)	C	National High Magnetic Field Laboratory (NHMFL)	MPA-Mag								
Chunlei Yue (G)	C	Tulane University	Physics and Engineering Physics								
Yanglin Zhu (G)	C	Tulane University	Department of Physics and Engineering Physics								
Haidong Zhou (S)	PI	University of Tennessee, Knoxville	Physics and Astronomy	NSF - National Science Foundation	DMR – Division of Materials	1350002	P14982	Studies on low temperature physical properties of new quantum	Condensed Matter Physics	3	21

# Appendix VI – User Proposals

Participants (Name, Role, Org., Dept.)		Funding Sources (Funding Agency, Division, Award #)		Proposal #	Proposal Title	Discipline	Exp. #	Days Used	
		Research			spin liquid and spin-orbital liquid candidates				
Qiang Chen (G)	C	University of Tennessee, Knoxville	Physics						
Eun Sang Choi (S)	C	National High Magnetic Field Laboratory (NHMFL)	Physics Department						
Zhiling Dun (G)	C	University of Tennessee, Knoxville	Physics						
David Graf (S)	C	National High Magnetic Field Laboratory (NHMFL)	DC Field CMS						
Qing Huang (G)	C	University of Tennessee, Knoxville	Physics						
Yuxuan Jiang (G)	C	Georgia Institute of Technology	School of Physics						
Ryan Sinclair (G)	C	University of Tennessee, Knoxville	Physics and Astronomy						
Faxian Xiu (S)	PI	Fudan University	Physics	National Natural Science Foundation of China	<b>P14980</b>	Magnetotransport study of unconventional Weyl orbits near quantum limit	Condensed Matter Physics	2	11.45
Ce Huang (G)	C	Fudan University	Department of Physics						
Yanwen Liu (G)	C	Fudan University	Physics						
Chaoyu Song (G)	C	Fudan University	Physics						
Xiang Yuan (G)	C	Fudan University	Physics						
Cheng Zhang (G)	C	University of Washington	Physics						
Bin MA (S)	PI	University of Minnesota, Twin Cities	Electrical and Computer Engineering	University of Minnesota	<b>P14948</b>	Phase transformation of Fe-N in high magnetic field annealing	Magnets, Materials, Testing, Instrumentation	1	4.06
Tim Murphy (S)	PI	National High Magnetic Field Laboratory (NHMFL)	Operations	No other support (i.e. this experiment is entirely supported by NHMFL users services via its core grant)	<b>P14939</b>	Maintenance & Testing of SC magnets & associated equipment	Condensed Matter Physics	3	20
Hongwoo Baek (S)	C	National High Magnetic Field Laboratory (NHMFL)	DC field						

# Appendix VI – User Proposals

		Participants (Name, Role, Org., Dept.)	Funding Sources (Funding Agency, Division, Award #)				Proposal #	Proposal Title	Discipline	Exp. #	Days Used
Glover Jones (T)	C	National High Magnetic Field Laboratory (NHMFL)	Instrumentation & Operations								
Stephen McGill (S)	C	National High Magnetic Field Laboratory (NHMFL)	Condensed Matter Science								
Ju-Hyun Park (S)	C	National High Magnetic Field Laboratory (NHMFL)	Instrumentation & Operations, User Support								
Dmitry Semenov (T)	C	National High Magnetic Field Laboratory (NHMFL)	DC Field								
Arkady Shehter (S)	PI *	National High Magnetic Field Laboratory (NHMFL)	NHMFL, DC Field Facility	NSF - National Science Foundation	DMR – Division of Materials Research	DMR- 1157490 and the State of Florida.	<b>P14902</b>	Bulk linear magnetoresistance in the quantum critical regime of La <sub>2-x</sub> Sr <sub>x</sub> CuO <sub>4</sub>	Condensed Matter Physics	1	3.74
Fedor Balakirev (S)	C	National High Magnetic Field Laboratory (NHMFL)	PFF								
Jonathan Betts (S)	C	National High Magnetic Field Laboratory (NHMFL)	NHMFL-PFF								
Greg Boebinger (S)	C	National High Magnetic Field Laboratory (NHMFL)	Directors Office								
David Graf (S)	C	National High Magnetic Field Laboratory (NHMFL)	DC Field CMS								
Xiujun Iian (G)	C	National High Magnetic Field Laboratory (NHMFL)	NHMFL								
Ross McDonald (S)	C	National High Magnetic Field Laboratory (NHMFL)	Physics								
Kimberly Modic (G)	C	National High Magnetic Field Laboratory (NHMFL)	PFF								
Philip Moll (S)	C	ETH Zürich	MPI Chemical Physics of Solids								
Brad Ramshaw (S)	C	Cornell University	Laboratory of Atomic and Solid State Physics								
Laurel Stritzinger (P)	C	National High Magnetic Field Laboratory (NHMFL)	Physics								



# Appendix VI – User Proposals

Participants (Name, Role, Org., Dept.)		Funding Sources (Funding Agency, Division, Award #)			Proposal #	Proposal Title	Discipline	Exp. #	Days Used		
Paul Cadden-Zimansky (S)	PI	Bard College	Physics	Research Corporation for Scientific Advancement		P14887	Phase Transitions in Graphene's n=0 Landau Level	Condensed Matter Physics	1	7	
Isobel Curtin (U)	C	Bard College	Physics								
Jia Li (P)	C	Columbia University	Physics								
Ethan Richman (U)	C	Bard College	Physics								
Mac Selesnick (U)	C	Bard College	Physics								
Evan Telford (G)	C	Columbia University	Physics								
John Wendt (U)	C	Bard College	Physics								
Teresa Puig (S)	PI	Institute of Material Science of Barcelona	SUMAN	No other support (i.e. this experiment is entirely supported by NHMFL users services via its core grant)		P14881	Pinning properties of CSD YBCO nanocomposites at ultrahigh magnetic fields and very low temperatures	Magnets, Materials, Testing, Instrumentation	1	5.9	
Dmytro Abraimov (S)	C	National High Magnetic Field Laboratory (NHMFL)	The Applied Superconductivity Center								
Jan Jaroszynski (S)	C	National High Magnetic Field Laboratory (NHMFL)	CMS								
David Larbalestier (S)	C	National High Magnetic Field Laboratory (NHMFL)	ASC								
Anna Palau (S)	C	Institute of Material Science of Barcelona	SUMAN								
Ferran Valles (G)	C	Institute of Material Science of Barcelona	SUMAN								
Tzu-Ming Lu (S)	PI	Sandia National Laboratories		DOE - Department of Energy	Office of Science - BES – Basic Energy Sciences	15018348	P14879	Magneto-transport properties of high-mobility two-dimensional holes in Ge/SiGe heterostructure field-effect transistors	Condensed Matter Physics	4	25.5
Jiun-Yun Li (S)	C	National Taiwan University	Electrical Engineering								
Alexey Suslov (S)	C	National High Magnetic Field Laboratory (NHMFL)	Condensed Matter Science								
Lisa Tracy (S)	C	Sandia National Laboratories	Quantum Phenomena								
I-Wei Chen (S)	PI	University of Pennsylvania	Materials Science and Engineering	NSF - National Science Foundation	DMR – Division of Materials	1409114	P14875	Sub-10 nm 1D/3D Disordered Electron Systems	Condensed Matter Physics	3	20

# Appendix VI – User Proposals

Participants (Name, Role, Org., Dept.)		Funding Sources (Funding Agency, Division, Award #)		Proposal #	Proposal Title	Discipline	Exp. #	Days Used			
Research											
Yanhao Dong (G)	C	University of Pennsylvania	Materials Science and Engineering								
Yang Lu (G)	C	University of Pennsylvania	Materials Science and Engineering								
Shuang Wu (G)	C	University of Pennsylvania	3231 Walnut Street, LRSM								
Eun Sang Choi (S)	PI	National High Magnetic Field Laboratory (NHMFL)	Physics Department	NSF - National Science Foundation	DMR – Division of Materials Research	1309146	<b>P14874</b>	Thermal conductivity measurements on magnetic multiferroic materials	Condensed Matter Physics	3	21
Hongwoo Baek (S)	C	National High Magnetic Field Laboratory (NHMFL)	DC field	supported by NHMFL users services via its core grant							
Shermane Benjamin (G)	C	National High Magnetic Field Laboratory (NHMFL)	Physics								
Haidong Zhou (S)	C	University of Tennessee, Knoxville	Physics and Astronomy								
Matthew Grayson (S)	PI	Northwestern University	Electrical Engineering & Computer Science	DOD - Department of Defense	U.S. Air Force	FA9550-15-1-0247	<b>P14870</b>	Magnetoresistance anisotropy in AIs $\nu = 1$ quantum Hall valley-ferromagnet	Condensed Matter Physics	1	5.91
Yang Tang (P)	C	Northwestern University	Electrical Engineering & Computer Science								
Toomas Room (S)	PI	National Institute of Chemical Physics and Biophysics	Chemical Physics	Other - Estonian Ministry of Education and Research Grant	Other	IUT23-03	<b>P14867</b>	Directional dichroism and spin waves in the canted AFM phase of multiferroic BiFeO <sub>3</sub>	Condensed Matter Physics	1	5.85
Sandor Bordacs (S)	C	Budapest University of Technology and Economics	Department of Physics								
Dániel Gergely Farkas (G)	C	Budapest University of Technology and Economics	Department of Physics								
Jurek Krzystek (S)	C	National High Magnetic Field Laboratory (NHMFL)	Condensed Matter Science								
David Szaller (G)	C	Budapest University of Technology and Economics	Department of Physics								
Komalavalli Thirunavukkuarasu (S)	C	National High Magnetic Field Laboratory (NHMFL)	EMR								

# Appendix VI – User Proposals

Participants (Name, Role, Org., Dept.)		Funding Sources (Funding Agency, Division, Award #)			Proposal #	Proposal Title	Discipline	Exp. #	Days Used		
Johan Viirok (G)	C	National Institute of Chemical Physics and Biophysics	Physics Laboratory								
Zhiqiang Li (S)	PI	SiChuan University	Physics	1000 Young Talent program of China		<b>P14864</b>	Magneto-optical Spectroscopy of New 2D Materials	Condensed Matter Physics	1	7	
Yongqing Li (S)	C	Institute of Physics, Chinese Academy of Sciences	Institute of Physics								
Guoyu Luo (G)	C	Sichuan University	Physics Department								
Yuanbo Zhang (S)	C	Fudan University	Physics								
Michael Zudov (S)	PI	University of Minnesota, Twin Cities	School of Physics and Astronomy	DOE - Department of Energy	Office of Science - BES – Basic Energy Sciences	ER 46640-SC0002567	<b>P14855</b>	Anisotropic and nonequilibrium transport in 2D systems	Condensed Matter Physics	3	22
Xlaojun Fu (G)	C	University of Minnesota, Twin Cities	Physics								
Michael Manfra (S)	C	Nokia Bell Labs	Semiconductor Physics Research								
Loren Pfeiffer (S)	C	Princeton University	Electrical Engineering								
Qianhui Shi (G)	C	University of Minnesota, Twin Cities	Physics								
Ken West (S)	C	Princeton University	Princeton Institute for the Science and Technology of Materials								
Timir Datta (S)	PI	University of South Carolina	Department of Physics and Astronomy	DOE - Department of Energy	NNSA – National Nuclear Security Administration	DE-NA0002630	<b>P14845</b>	Geometric manipulation of Quantum Transport in Graphene with Antidot Arrays	Condensed Matter Physics	1	24
Mohammed Abdi (U)	C	Benedict College	Department of Physics and Engineering								
Yassine Jaoudi (U)	C	Benedict College	Department of Physics and Engineering								
Lei Wang (G)	C	University of South Carolina	Department of Physics								
Ming Yin (S)	C	Benedict College	Physics/Engineering								

# Appendix VI – User Proposals

		Participants (Name, Role, Org., Dept.)		Funding Sources (Funding Agency, Division, Award #)		Proposal #	Proposal Title	Discipline	Exp. #	Days Used
Tim Murphy (S)	PI	National High Magnetic Field Laboratory (NHMFL)	Operations	No other support (i.e. this experiment is entirely supported by NHMFL users services via its core grant)		P14838	Testing of Resistive and Hybrid magnets and power supplies in the DC Field Facility	Magnets, Materials, Testing, Instrumentation	20	48.85
Scott Bole (S)	C	National High Magnetic Field Laboratory (NHMFL)	MS&T							
William Brey (S)	C	National High Magnetic Field Laboratory (NHMFL)	NMR							
Bryon Dalton (S)	C	National High Magnetic Field Laboratory (NHMFL)	Instrumentation							
Larry Gordon (T)	C	National High Magnetic Field Laboratory (NHMFL)	Instrumentation							
Scott Hannahs (S)	C	National High Magnetic Field Laboratory (NHMFL)	Instrumentation							
Ilya Litvak (S)	C	National High Magnetic Field Laboratory (NHMFL)	CIMAR/NMR							
Scott Maier (T)	C	National High Magnetic Field Laboratory (NHMFL)	Instrumentation and Operations							
Ju-Hyun Park (S)	C	National High Magnetic Field Laboratory (NHMFL)	Instrumentation & Operations, User Support							
Arneil Reyes (S)	C	National High Magnetic Field Laboratory (NHMFL)	Condensed Matter Science							
Yuriy Sakhratov (P)	C	Kazan State Power Engineering University	Department of Physics							
Dmitry Smirnov (S)	C	National High Magnetic Field Laboratory (NHMFL)	Instrumentation & Operations							
Julia Smith (S)	C	National High Magnetic Field Laboratory (NHMFL)	DC Field							
Jack Toth (S)	C	National High Magnetic Field Laboratory (NHMFL)	MS&T							

# Appendix VI – User Proposals

		Participants (Name, Role, Org., Dept.)		Funding Sources (Funding Agency, Division, Award #)			Proposal #	Proposal Title	Discipline	Exp. #	Days Used
Benjamin Hunt (S)	PI	Carnegie Mellon University	Physics	Kaufman Foundation Young Investigator			P14776	Upper Critical Fields of Two-dimensional Superconducting Transition Metal Dichalcogenides	Condensed Matter Physics	2	8.85
Sergio de la Barrera (P)	C	Carnegie Mellon University	Department of Physics								
Cory Dean (S)	C	City College of New York	Physics								
Devashish Gopalan (G)	C	Carnegie Mellon University	Physics								
James Hone (S)	C	Columbia University	Mechanical Engineering								
David Mandrus (S)	C	University of Tennessee, Knoxville	Materials Science and Engineering								
Michael Sinko (G)	C	Carnegie Mellon University	Physics								
Evan Telford (G)	C	Columbia University	Physics								
Adam Tsen (P)	C	Columbia University	Physics								
Sufei Shi (S)	PI	Rensselaer Polytechnic Institute	Chemical and Biological Engineering	Rensselaer Polytechnic Institute			P14775	Magneto-transport of van der Waals Heterostructure	Engineering	4	28
Yanwen Chen (G)	C	Rensselaer Polytechnic Institute	Chemical and Biological Engineering	RPI startup							
Zhengguang Lu (G)	C	National High Magnetic Field Laboratory (NHMFL)	Physics								
Mykhaylo Ozerov (S)	C	National High Magnetic Field Laboratory (NHMFL)	Condensed Matter Science, DC Field CMS								
Ju-Hyun Park (S)	C	National High Magnetic Field Laboratory (NHMFL)	Instrumentation & Operations, User Support								
Dmitry Smirnov (S)	C	National High Magnetic Field Laboratory (NHMFL)	Instrumentation & Operations								
Lei Wang (G)	C	Columbia University	Mechanical Engineering								
Tianmeng Wang (G)	C	Rensselaer Polytechnic Institute	Chemical and Biological Engineering								
Paul McEuen (S)	PI	Cornell University	Physics	DOD - Department of Defense	U.S. Air Force	MURI: FA9550-16-1-0031					

# Appendix VI – User Proposals

	Participants (Name, Role, Org., Dept.)			Funding Sources (Funding Agency, Division, Award #)			Proposal #	Proposal Title	Discipline	Exp. #	Days Used
Long Ju (P)	C	Cornell University	Physics					two-dimensional materials			
Seonghill Moon (G)	C	National High Magnetic Field Laboratory (NHMFL)	Physics								
Dmitry Smirnov (S)	C	National High Magnetic Field Laboratory (NHMFL)	Instrumentation & Operations								
Feng Wang (S)	C	University of California, Berkeley	Department of physics								
Lei Wang (G)	C	Columbia University	Mechanical Engineering								
David Hilton (S)	PI	University of Alabama, Birmingham	Physics	NSF - National Science Foundation	DMR – Division of Materials Research	1056827	<b>P14772</b>	Terahertz Time-domain Spectroscopy of Two-dimensional Materials in the Split Florida Helix	Condensed Matter Physics	2	9.26
Biplob Barman (P)	C	University of Alabama, Birmingham	Physics	NSF - National Science Foundation	DMR – Division of Materials Research	1409473					
Ashlyn Burch (G)	C	University of Alabama, Birmingham	Physics	DOE - Department of Energy	Office of Science - BES – Basic Energy Sciences	DE-SC0012635					
Jeremy Curtis (G)	C	University of Alabama, Birmingham	Physics								
Denis Karaiskaj (S)	C	University of South Florida	Physics								
Garrison Linn (G)	C	University of Alabama, Birmingham	Physics								
Aidan O'Beirne (U)	C	University of Alabama, Birmingham	Physics								
Joanna Schmidt (U)	C	University of Alabama, Birmingham	Physics								
Jie Shan (S)	C	Pennsylvania State University	Physics								
Chris Landee (S)	PI	Clark University	Department of Physics	Clark University			<b>P14766</b>	Magnetization Studies of Novel Quantum Magnets: Spin Ladders and Two-Dimensional Heisenberg	Condensed Matter Physics	1	11.5
Jeff Monroe (G)	C	Clark University	Chemistry								
Mark Turnbull (S)	C	Clark University	Chemistry								

# Appendix VI – User Proposals

Participants (Name, Role, Org., Dept.)		Funding Sources (Funding Agency, Division, Award #)			Proposal #	Proposal Title	Discipline	Exp. #	Days Used		
David Young (S)	PI	Louisiana State University	College of Science	NSF - National Science Foundation	DMR – Division of Materials Research	1306392	<b>P14764</b>	Exploring the Fermi surface of the noncentrosymmetric chiral superconductor BiPd	Condensed Matter Physics	1	7
Mojammel Alam Khan (G)	C	Louisiana State University	Department Of Physics & Astronomy	DOE - Department of Energy		DE-SC0012432					
Qi Li (S)	PI	Pennsylvania State University	Physics	NSF - National Science Foundation	DMR – Division of Materials Research	DMR 1411166	<b>P14762</b>	Low temperature and high magnetic field measurements of two dimensional electron gases on transition metal oxide surfaces	Condensed Matter Physics	1	4.79
Bailey Bedford (G)	C	Pennsylvania State University	Physics								
Ludi Miao (P)	C	Pennsylvania State University	Physics								
Jing Wang (G)	C	Pennsylvania State University	Physics								
Seungyong Hahn (S)	PI	National High Magnetic Field Laboratory (NHMFL)	Applied Superconductivity Center, Mechanical Engineering	NHMFL UCGP - User Collaboration Grants Program		227000-520-030759, 5095	<b>P14760</b>	No-Insulation Type High Temperature Superconductor Winding Techniques for All-Superconducting >30 T DC User Magnets	Magnets, Materials, Testing, Instrumentation	3	7.73
Dmytro Abrahimov (S)	C	National High Magnetic Field Laboratory (NHMFL)	The Applied Superconductivity Center								
Scott Bole (S)	C	National High Magnetic Field Laboratory (NHMFL)	MS&T								
Iain Dixon (S)	C	National High Magnetic Field Laboratory (NHMFL)	MS&T								
Jan Jaroszynski (S)	C	National High Magnetic Field Laboratory (NHMFL)	CMS								
Kwanglok Kim (O)	C	National High Magnetic Field Laboratory (NHMFL)	Applied Superconductivity Center								
Kwangmin Kim (P)	C	National High Magnetic Field Laboratory (NHMFL)	Applied Superconductivity Center								
Seokho Kim (S)	C	National High Magnetic Field Laboratory (NHMFL)	ASC								

# Appendix VI – User Proposals

	Participants (Name, Role, Org., Dept.)	Funding Sources (Funding Agency, Division, Award #)	Proposal #	Proposal Title	Discipline	Exp. #	Days Used
Emsley Marks (T)	C National High Magnetic Field Laboratory (NHMFL)	MS&T					
William Marshall (S)	C National High Magnetic Field Laboratory (NHMFL)	MS&T					
George Miller (S)	C National High Magnetic Field Laboratory (NHMFL)	MS&T					
So Noguchi (S)	C Hokkaido University	Graduate School of Information Science and Technology					
Patrick Noyes (S)	C National High Magnetic Field Laboratory (NHMFL)	MST					
Tom Painter (S)	C National High Magnetic Field Laboratory (NHMFL)	MS&T					
Aixia Xu (S)	C University of Houston	Texas Superconductivity Center at the University of Houston					
Greg Scholes (S)	PI Princeton University	Chemistry	Princeton University	<b>P14756</b>	Probing Excitonic Coupling in Artificial Light Harvesting Complexes by High Magnetic Field	Chemistry, Geochemistry	3 11.16
Jacob Dean (P)	C University of Toronto	Dept. of Chemistry					
Bryan Kudisch (S)	C Princeton University	Chemistry					
Margherita Maiuri (P)	C Princeton University	Chemistry					
Stephen McGill (S)	C National High Magnetic Field Laboratory (NHMFL)	Condensed Matter Science					
Luca Moretti (P)	C Princeton University	Chemistry					
Zhehong Gan (S)	PI National High Magnetic Field Laboratory (NHMFL)	NHMFL	NSERC of Canada	<b>P14747</b>	Quadrupolar nuclei NMR using 36 T Series Connected Hybrid Magnet	Chemistry, Geochemistry	12 35.47
William Brey (S)	C National High Magnetic Field Laboratory (NHMFL)	NMR	Supported by NHMFL users services via its core grant				
Tim Cross (S)	C National High Magnetic Field Laboratory (NHMFL)	NHMFL/Chemistry & Biochemistry					
Robert Griffin (S)	C Massachusetts	Chemistry					



# Appendix VI – User Proposals

Participants (Name, Role, Org., Dept.)		Funding Sources (Funding Agency, Division, Award #)			Proposal #	Proposal Title	Discipline	Exp. #	Days Used	
Ivan Hung (S)	C	Institute of Technology National High Magnetic Field Laboratory (NHMFL)	CIMAR/NMR							
Ilya Litvak (S)	C	National High Magnetic Field Laboratory (NHMFL)	CIMAR/NMR							
Alexander Nevzorov (S)	C	North Carolina State University	Chemistry							
Joana Paulino (P)	C	National High Magnetic Field Laboratory (NHMFL)	CIMAR							
Robert Schurko (S)	C	University of Windsor	Chemistry							
Alex Smirnov (S)	C	North Carolina State University	Chemistry							
Jack Toth (S)	C	National High Magnetic Field Laboratory (NHMFL)	MS&T							
Xiaoling Wang (P)	C	National High Magnetic Field Laboratory (NHMFL)	NMR							
Gang Wu (S)	C	Queen's University at Kingston	Chemistry							
Hugen Yan (S)	PI	Fudan University	Physics	Fudan University	<b>P14746</b>	Magneto-optical Spectroscopy of emerging Dirac and Weyl semimetals	Condensed Matter Physics	1	14	
Ce Huang (G)	C	Fudan University	Department of Physics							
Zhiqiang Li (S)	C	SiChuan University	Physics							
Yanwen Liu (G)	C	Fudan University	Physics							
Dmitry Smirnov (S)	C	National High Magnetic Field Laboratory (NHMFL)	Instrumentation & Operations							
Chaoyu Song (G)	C	Fudan University	Physics							
Faxian Xiu (S)	C	Fudan University	Physics							
Xiang Yuan (G)	C	Fudan University	Physics							
Cheng Zhang (G)	C	University of Washington	Physics							
Ryan Baumbach (S)	PI	National High Magnetic Field Laboratory (NHMFL)	CMS	NSF - National Science Foundation	DMR – Division of Materials Research	DMR-1157490	<b>P14728</b> High magnetic fields and the puzzle of f-electron localization-itinerancy physics	Condensed Matter Physics	1	5.55

# Appendix VI – User Proposals

		Participants (Name, Role, Org., Dept.)	Funding Sources (Funding Agency, Division, Award #)	Proposal #	Proposal Title	Discipline	Exp. #	Days Used	
Alexander Breindel (G)	C	University of California, San Diego	Physics						
Kuan-Wen Chen (G)	C	National High Magnetic Field Laboratory (NHMFL)	CMS						
David Graf (S)	C	National High Magnetic Field Laboratory (NHMFL)	DC Field CMS						
Kevin Huang (P)	C	National High Magnetic Field Laboratory (NHMFL)	CMS						
Marcelo Jaime (S)	C	National High Magnetic Field Laboratory (NHMFL)	Physics						
Trevor Keiber (P)	C	University of California, San Diego	Physics						
You Lai (G)	C	National High Magnetic Field Laboratory (NHMFL)	Physics						
Brian Maple (S)	C	University of California, San Diego	Inst for Pure & Applied Physical Sciences						
Ross McDonald (S)	C	National High Magnetic Field Laboratory (NHMFL)	Physics						
Sheng Ran (P)	C	University of California, San Diego	Physics						
Myron Salamon (S)	C	University of Texas, Dallas	Physics						
Arkady Shehter (S)	C	National High Magnetic Field Laboratory (NHMFL)	NHMFL, DC Field Facility						
Laurel Stritzinger (P)	C	National High Magnetic Field Laboratory (NHMFL)	Physics						
Liusuo Wu (P)	C	Oak Ridge National Laboratory	Quantum Condensed Matter Division						
Jun Yan (S)	PI *	University of Massachusetts	Physics	Armstrong fund for science	<b>P13659</b>	Electronic Properties Of Layered Chalcogenides In A Strong Magnetic Field	Condensed Matter Physics	1	2.68
Shao-Yu Chen (G)	C	University of Massachusetts	Physics						

# Appendix VI – User Proposals

Participants (Name, Role, Org., Dept.)		Funding Sources (Funding Agency, Division, Award #)			Proposal #	Proposal Title	Discipline	Exp. #	Days Used		
Thomas Goldstein (G)	C	University of Massachusetts	Physics								
Zhengguang Lu (G)	C	National High Magnetic Field Laboratory (NHMFL)	Physics								
Dmitry Smirnov (S)	C	National High Magnetic Field Laboratory (NHMFL)	Instrumentation & Operations								
Prasenjit Guptasarma (S)	PI	University of Wisconsin, Milwaukee	Department of Physics	University of Wisconsin Milwaukee	<b>P13648</b>	Using magneto-conductivity to explore Spin-Orbit Coupling and Weak Anti-localization in Superconducting Topological Insulators.	Condensed Matter Physics	1	7		
William Coniglio (S)	C	National High Magnetic Field Laboratory (NHMFL)									
Lorne Forsythe (G)	C	University of Wisconsin, Milwaukee	Dept of Physics & Dept of Mechanical Engineering								
Uma Garg (G)	C	University of Wisconsin, Milwaukee	Physics								
Audrey Grockowiak (S)	C	National High Magnetic Field Laboratory (NHMFL)	DC Field/CMS								
Yanan Li (G)	C	University of Wisconsin, Milwaukee	Physics								
William Rexhausen (G)	C	University of Wisconsin, Milwaukee	Physics								
Nathaniel Smith (G)	C	University of Wisconsin, Milwaukee	Physics								
Alexey Suslov (S)	C	National High Magnetic Field Laboratory (NHMFL)	Condensed Matter Science								
Stan Tozer (S)	C	National High Magnetic Field Laboratory (NHMFL)	Physics								
Minhyea Lee (S)	PI	University of Colorado, Boulder	Physics	DOE - Department of Energy	Office of Science - BES – Basic Energy Sciences	DE-SC0006888	<b>P13639</b>	Investigation of magnetic anisotropy in low dimensional systems	Condensed Matter Physics	2	15.38
Ian Leahy (G)	C	University of Colorado, Boulder	Physics	University of Colorado Boulder							
Christopher Pocs (G)	C	University of Colorado, Boulder	Physics								

# Appendix VI – User Proposals

		Participants (Name, Role, Org., Dept.)		Funding Sources (Funding Agency, Division, Award #)			Proposal #	Proposal Title	Discipline	Exp. #	Days Used
Peter Siegfried (G)	C	University of Colorado, Boulder	Physics								
Michael Baenitz (S)	PI *	Max Planck Institute for Chemical Physics of Solids, Dresden, Germany	Physics of quantum matter	NSF - National Science Foundation	DMR – Division of Materials Research	1157490	<b>P13638</b>	High Field Magnetic Anisotropy of RuCl <sub>3</sub> using Torque Magnetometry	Condensed Matter Physics	1	5.35
Mayukh Majumder (P)	C	Max Planck Institute	Physics of Quantum Materials								
Ross McDonald (S)	C	National High Magnetic Field Laboratory (NHMFL)	Physics								
Kimberly Modic (G)	C	National High Magnetic Field Laboratory (NHMFL)	PFF								
Brad Ramshaw (S)	C	Cornell University	Laboratory of Atomic and Solid State Physics								
Marcus Schmidt (S)	C	Max Planck Institute	Chemische Metallkunde								
Arkady Shehter (S)	C	National High Magnetic Field Laboratory (NHMFL)	NHMFL, DC Field Facility								
Z. Vally Vardeny (S)	PI	University of Utah	Department of Physics & Astronomy	NSF - National Science Foundation	DMR – Division of Materials Research	1404634	<b>P13618</b>	High field magneto-photoluminescence studies of organic and hybrid organic/inorganic semiconductors with tunable spin-orbit coupling	Condensed Matter Physics	1	4.09
Eitan Ehrenfreund (S)	C	University of Utah	Department of Physics & Astronomy								
Ryan McLaughlin (G)	C	University of Utah	Department of Physics & Astronomy								
Dali Sun (P)	C	University of Utah	Department of Physics & Astronomy								
Chuang Zhang (P)	C	University of Utah	Dept. of Physics & Astronomy								
Ziling Xue (S)	PI	University of Tennessee, Knoxville	Chemistry	NSF - National Science Foundation	CHE – Division of Chemistry	CHE-1362548	<b>P13617</b>	Probing Molecular Magnetism by Infrared and Raman Spectroscopies in Magnetic Fields	Chemistry, Geochemistry	3	21
Zhiqiang Li (S)	C	SiChuan University	Physics	NSF - National Science Foundation	CHE – Division of Chemistry	CHE-1633870					
Zhengguang Lu (G)	C	National High Magnetic Field Laboratory (NHMFL)	Physics								

# Appendix VI – User Proposals

Participants (Name, Role, Org., Dept.)		Funding Sources (Funding Agency, Division, Award #)			Proposal #	Proposal Title	Discipline	Exp. #	Days Used		
Clay Mings (G)	C	University of Tennessee, Knoxville	Chemistry								
Duncan Moseley (G)	C	University of Tennessee, Knoxville	Chemistry								
Mykhaylo Ozerov (S)	C	National High Magnetic Field Laboratory (NHMFL)	Condensed Matter Science, DC Field CMS								
Dmitry Smirnov (S)	C	National High Magnetic Field Laboratory (NHMFL)	Instrumentation & Operations								
Shelby Stavretis (G)	C	University of Tennessee, Knoxville	Chemistry								
Komalavalli Thirunavukkuarasu (S)	C	National High Magnetic Field Laboratory (NHMFL)	EMR								
Christianne Beekman (S)	PI	National High Magnetic Field Laboratory (NHMFL)	Physics	FSU		<b>P13610</b>	Exploring the Structure-Property Relationship in Thin Films of Strongly Correlated Electron Systems	Condensed Matter Physics	3	29	
Naween Anand (G)	C	University of Florida	Department of Physics								
Kevin Barry (G)	C	Florida State University (FSU)	Physics								
David Graf (S)	C	National High Magnetic Field Laboratory (NHMFL)	DC Field CMS								
Haidong Zhou (S)	C	University of Tennessee, Knoxville	Physics and Astronomy								
Zhiqiang Mao (S)	PI	Tulane University	Physics Department	DOE - Department of Energy	Office of Science - BES – Basic Energy Sciences	DOE EPSCoR Grant No. DE-SC0012432	<b>P12574</b>	Studies of Quantum Oscillations in the Dirac semimetal SrMnSb <sub>2</sub> and Weyl semimetal TaP	Condensed Matter Physics	1	5.23
Fedor Balakirev (S)	C	National High Magnetic Field Laboratory (NHMFL)	PFF								
David Graf (S)	C	National High Magnetic Field Laboratory (NHMFL)	DC Field CMS								
Jin Hu (S)	C	Tulane University	Physics								
Marcelo Jaime (S)	C	National High Magnetic Field Laboratory (NHMFL)	Physics								

# Appendix VI – User Proposals

Participants (Name, Role, Org., Dept.)		Funding Sources (Funding Agency, Division, Award #)			Proposal #	Proposal Title	Discipline	Exp. #	Days Used		
Jinyu Liu (G)	C	Tulane University	Department of Physics and Engineering Physics								
Zhiqiang Mao (S)	C	Tulane University	Physics Department								
Ross McDonald (S)	C	National High Magnetic Field Laboratory (NHMFL)	Physics								
Chunlei Yue (G)	C	Tulane University	Physics and Engineering Physics								
Yanglin Zhu (G)	C	Tulane University	Department of Physics and Engineering Physics								
Diyar Talbayev (S)	PI *	Tulane University	Physics and Engineering Physics	NSF - National Science Foundation	DMR – Division of Materials Research	1554866	<b>P12572</b>	Investigation of terahertz-frequency anomalous Hall effect in ferromagnetic half-metal CrO <sub>2</sub>	Condensed Matter Physics	1	2.34
Ashlyn Burch (G)	C	University of Alabama, Birmingham	Physics								
David Hilton (S)	C	National High Magnetic Field Laboratory (NHMFL)	Magnet Science & Technology								
Stephen McGill (S)	C	National High Magnetic Field Laboratory (NHMFL)	Condensed Matter Science								
Shukai Yu (G)	C	Tulane University	Physics								
Suchitra Sebastian (S)	PI	University of Cambridge	Physics	European Research Council (ERC)			<b>P12546</b>	Accessing the normal state of the cuprate superconductors	Condensed Matter Physics	2	11.76
Patricia Alireza (S)	C	University of Cambridge	Physics								
William Coniglio (S)	C	National High Magnetic Field Laboratory (NHMFL)									
Sofia Coronel (G)	C	University of Cambridge	Physics								
Alexander Davies (G)	C	University of Cambridge	Physics								
Neil Harrison (S)	C	National High Magnetic Field Laboratory (NHMFL)	Physics								
Mate Hartstein (G)	C	University of Cambridge	Physics								
Yu Hsu (G)	C	University of Cambridge	Physics								

# Appendix VI – User Proposals

		Participants (Name, Role, Org., Dept.)		Funding Sources (Funding Agency, Division, Award #)		Proposal #	Proposal Title	Discipline	Exp. #	Days Used
Hsu Liu (G)	C	University of Cambridge	Physics							
Gil Lonzarich (S)	C	University of Cambridge	Physics							
Grace Zhang (U)	C	Massachusetts Institute of Technology	Physics							
Andres Saul (S)	PI	Aix-Marseille University	CINaM/CNRS	No other support (i.e. this experiment is entirely supported by NHMFL users services via its core grant)		<b>P11536</b>	Lattice studies in the Shastry-Sutherland compound SrCu <sub>2</sub> (BO <sub>3</sub> ) <sub>2</sub>	Condensed Matter Physics	1	2.15
Peter Christianen (S)	C	Radboud University Nijmegen	High Field Magnet Laboratory							
Hanna Dabkowska (S)	C	McMaster University	Physics and Astronomy							
Marcelo Jaime (S)	C	National High Magnetic Field Laboratory (NHMFL)	Physics							
Zhengguang Lu (G)	C	National High Magnetic Field Laboratory (NHMFL)	Physics							
Dmitry Smirnov (S)	C	National High Magnetic Field Laboratory (NHMFL)	Instrumentation & Operations							
Komalavalli Thirunavukkuarasu (S)	C	National High Magnetic Field Laboratory (NHMFL)	EMR							
Emanuel Tutuc (S)	PI	University of Texas, Austin	Electrical and Computer Engineering	Semiconductor Research Corporation		<b>P11534</b>	Magnetotransport Properties of Interacting Electrons in van der Waals Heterostructures	Condensed Matter Physics	2	10.61
Babak Fallahzad (G)	C	University of Texas, Austin	Electrical and Computer Engineering							
Kyoungwan Kim (G)	C	University of Texas, Austin	Electrical and Computer Engineering							
Stefano Larentis (G)	C	University of Texas, Austin	Electrical and Computer Engineering							
Hema Chandra Prakash Movva (G)	C	University of Texas, Austin	Electrical and Computer Engineering							
Alexander Tsirlin (S)	PI	National Institute of Chemical Physics and Biophysics	Chemical physics	Estonian Research Agency		<b>P11530</b>	(H,T)-phase diagram of the frustrated spin-1/2 chain system in beta-TeVO <sub>4</sub>	Condensed Matter Physics	1	5.91

# Appendix VI – User Proposals

Participants (Name, Role, Org., Dept.)		Funding Sources (Funding Agency, Division, Award #)			Proposal #	Proposal Title	Discipline	Exp. #	Days Used		
Marcelo Jaime (S)	C	National High Magnetic Field Laboratory (NHMFL)	Physics								
Joosep Link (U)	C	National Institute of Chemical Physics and Biophysics	Physics								
Arneil Reyes (S)	C	National High Magnetic Field Laboratory (NHMFL)	Condensed Matter Science								
Raivo Stern (S)	C	National Institute of Chemical Physics and Biophysics	Chemical Physics								
Dagmar Weickert (S)	C	National High Magnetic Field Laboratory (NHMFL)	MPA-Mag								
Yasu Takano (S)	PI	University of Florida	Physics	NSF - National Science Foundation	DMR – Division of Materials Research	DMR1350002	<b>P11528</b>	Magnetic and thermal properties of novel quantum magnets	Condensed Matter Physics	3	21
Eun Sang Choi (S)	C	National High Magnetic Field Laboratory (NHMFL)	Physics Department	JSPS							
Sara Haravifard (S)	C	Duke University	Department of Physics								
Xinzhe Hu (G)	C	University of Florida	Physics								
Dustin Watts (U)	C	Berea College	Physics								
Swapnil Yadav (G)	C	University of Florida	Physics								
Haidong Zhou (S)	C	University of Tennessee, Knoxville	Physics and Astronomy								
Andrea Young (S)	PI	University of California, Santa Barbara	Physics	NSF - National Science Foundation	DMR – Division of Materials Research	1636607	<b>P11522</b>	Magnetocapacitance matrix for bilayer two dimensional electron systems	Biology, Biochemistry, Biophysics	3	17.22
Cory Dean (S)	C	City College of New York	Physics								
Benjamin Hunt (S)	C	Carnegie Mellon University	Physics								
Carlos Kometter (U)	C	University of California, Santa Barbara	Physics								
Jia Li (P)	C	Columbia University	Physics								
Eric Spanton (P)	C	University of California, Santa	Physics								



# Appendix VI – User Proposals

Participants (Name, Role, Org., Dept.)		Funding Sources (Funding Agency, Division, Award #)			Proposal #	Proposal Title	Discipline	Exp. #	Days Used		
Haoxin Zhou (G)	C	Barbara University of California, Santa Barbara	Physics								
Alexander Zibrov (G)	C	University of California, Santa Barbara	Physics								
Kin Fai Mak (S)	PI	Pennsylvania State University	Physics	DOE - Department of Energy	Office of Science - BES – Basic Energy Sciences	DESC0013883	<b>P11513</b>	Probing superconductivity in atomically thin transition metal dichalcogenides	Condensed Matter Physics	1	5.35
Shengwei Jiang (P)	C	Pennsylvania State University	Physics								
Jie Shan (S)	C	Pennsylvania State University	Physics								
Egon Sohn (G)	C	Pennsylvania State University	Department of Physics								
Zefang Wang (G)	C	Pennsylvania State University	Physics								
Xiaoxiang Xi (P)	C	Pennsylvania State University	Physics								
Luis Balicas (S)	PI	National High Magnetic Field Laboratory (NHMFL)	Condensed Matter Experiment	DOE - Department of Energy	Office of Science - BES – Basic Energy Sciences	DE- SC0002613	<b>P11512</b>	Exploring the electronic properties of Weyl semimetal candidates	Condensed Matter Physics	4	22.22
Ryan Baumbach (S)	C	National High Magnetic Field Laboratory (NHMFL)	CMS								
Yu Che Chiu (G)	C	National High Magnetic Field Laboratory (NHMFL)	Condensed Matter Sciences								
David Graf (S)	C	National High Magnetic Field Laboratory (NHMFL)	DC Field CMS								
Zahid Hasan (S)	C	Princeton University	Physics								
Michelle Johannes (S)	C	U.S. Naval Research Laboratory	Center for Computational Materials Science								
Daniel Rhodes (P)	C	Columbia University	Mechanical Engineering								
Rico Schoenemann (G)	C	Helmholtz-Zentrum Dresden-Rossendorf	Dresden High Magnetic Field Laboratory								

# Appendix VI – User Proposals

Participants (Name, Role, Org., Dept.)		Funding Sources (Funding Agency, Division, Award #)		Proposal #	Proposal Title	Discipline	Exp. #	Days Used	
WenKai Zheng (G)	C	National High Magnetic Field Laboratory (NHMFL)	Condensed Matter Sciences						
Qiong Zhou (G)	C	National High Magnetic Field Laboratory (NHMFL)	Condensed Matter Sciences						
Seongshik Oh (S)	PI	Rutgers University, New Brunswick	Physics and Astronomy	Gordon and Betty Moore Foundation	<b>P11509</b>	Search for quantum Hall effect in interface-engineered Bi <sub>2</sub> Se <sub>3</sub> thin films with record low sheet carrier density and high mobility	Condensed Matter Physics	2	10.75
Nikesh Koirala (G)	C	Rutgers University, New Brunswick	Physics	NSF - National Science Foundation	EFMA-1542798				
Jisoo Moon (G)	C	Rutgers University, New Brunswick	Physics	Gordon and Betty Moore Foundation EPIQS Initiative					
Maryam Salehi (G)	C	Rutgers University, New Brunswick	Physics/MSE						
Pavel Shibayev (G)	C	Rutgers University, New Brunswick	Physics and Astronomy						
Gil Lonzarich (S)	PI	University of Cambridge	Physics	European Research Council (ERC)	<b>P09598</b>	High magnetic field measurements of high temperature superconductors	Condensed Matter Physics	2	8.39
Alexander Davies (G)	C	University of Cambridge	Physics						
Neil Harrison (S)	C	National High Magnetic Field Laboratory (NHMFL)	Physics						
Mate Hartstein (G)	C	University of Cambridge	Physics						
Yu Hsu (G)	C	University of Cambridge	Physics						
Hsu Liu (G)	C	University of Cambridge	Physics						
Suchitra Sebastian (S)	C	University of Cambridge	Physics						
Greg Wallace (G)	C	University of Cambridge	Quantum Matter						
Amalia Coldea (S)	PI	University of Oxford	Clarendon Laboratory	EPSRC, UK	<b>P09591</b>	Using ultra-high magnetic fields to access the electronic structure of novel superconducting materials	Condensed Matter Physics	1	5.92
Amir Abbas Haghighirad (S)	C	University of Oxford	Physics						
David Graf (S)	C	National High Magnetic Field Laboratory (NHMFL)	DC Field CMS						
Pascal Reiss (P)	C	University of Oxford	Clarendon Laboratory						

# Appendix VI – User Proposals

Participants (Name, Role, Org., Dept.)		Funding Sources (Funding Agency, Division, Award #)		Proposal #	Proposal Title	Discipline	Exp. #	Days Used	
Stan Tozer (S)	C	National High Magnetic Field Laboratory (NHMFL)	Physics						
Dmitry Smirnov (S)	PI	National High Magnetic Field Laboratory (NHMFL)	Instrumentation & Operations	No other support (i.e. this experiment is entirely supported by NHMFL users services via its core grant)	<b>P09590</b>	Testing new magneto-optical probes and new magneto-spectroscopy techniques	Magnets, Materials, Testing, Instrumentation	3	22.55
Yuxuan Jiang (G)	C	Georgia Institute of Technology	School of Physics						
Zhigang Jiang (S)	C	Georgia Institute of Technology	School of Physics						
Zhengguang Lu (G)	C	National High Magnetic Field Laboratory (NHMFL)	Physics						
Seonghill Moon (G)	C	National High Magnetic Field Laboratory (NHMFL)	Physics						
Mykhaylo Ozerov (S)	C	National High Magnetic Field Laboratory (NHMFL)	Condensed Matter Science, DC Field CMS						
Dmytro Abraimov (S)	PI	National High Magnetic Field Laboratory (NHMFL)	The Applied Superconductivity Center	No other support (i.e. this experiment is entirely supported by NHMFL users services via its core grant)	<b>P09585</b>	Comparative study of Ic(B) for (Re)BCO, Bi-2223 and Bi-2212 conductors from different manufactures.	Magnets, Materials, Testing, Instrumentation	1	5.73
Fedor Balakirev (S)	C	National High Magnetic Field Laboratory (NHMFL)	PFF						
Ashleigh Francis (T)	C	National High Magnetic Field Laboratory (NHMFL)	ASC						
Seungyong Hahn (S)	C	National High Magnetic Field Laboratory (NHMFL)	Applied Superconductivity Center, Mechanical Engineering						
Jan Jaroszynski (S)	C	National High Magnetic Field Laboratory (NHMFL)	CMS						
Kwanglok Kim (O)	C	National High Magnetic Field Laboratory (NHMFL)	Applied Superconductivity Center						
Jun Sung Kim (S)	PI	Pohang University of Science and Technology	Physics	National Research Foundation of Korea	<b>P09571</b>	Quantum oscillations and magnetotransport properties of layered	Condensed Matter Physics	1	5.31

# Appendix VI – User Proposals

Participants (Name, Role, Org., Dept.)		Funding Sources (Funding Agency, Division, Award #)		Proposal #	Proposal Title	Discipline	Exp. #	Days Used	
Sang Wook Cheong (S)	C	Rutgers University, New Brunswick	Physics and Astronomy		transition-metal chalcogenide single crystals				
Eun Sang Choi (S)	C	National High Magnetic Field Laboratory (NHMFL)	Physics Department						
ManJin Eom (G)	C	Pohang University of Science and Technology	Physics						
Woun Kang (S)	C	Ewha Womans University	Department of Physics						
Hoil Kim (G)	C	Pohang University of Science and Technology	Physics						
ChangIl Kwon (G)	C	Pohang University of Science and Technology	Physics						
Jong Mok Ok (G)	C	Pohang University of Science and Technology	Physics						
Satoru Nakatsuji (S)	PI	University of Tokyo	Institute for Solid State Physics	Japanese Society for the Promotion of Science (JSPS)	P09560	Field and Pressure Tuning of Anomalous Metallic State in the Mixed Valence Compound a-YbAlB4	Condensed Matter Physics	1	5.46
Luis Balicas (S)	C	National High Magnetic Field Laboratory (NHMFL)	Condensed Matter Experiment						
Daniel Rhodes (P)	C	Columbia University	Mechanical Engineering						
Rico Schoenemann (G)	C	Helmholtz-Zentrum Dresden-Rossendorf	Dresden High Magnetic Field Laboratory						
Yasuyuki Shimura (P)	C	University of Tokyo	Institute for Solid State Physics						
YounJung Jo (S)	PI	Kyungpook National University	Physics	National Research Fund by the Korea Government	P09542	Unconventional anisotropic magnetoresistance in a canted antiferromagnet	Condensed Matter Physics	1	7
Young Jai Choi (S)	C	Yonsei University	Physics						
Woun Kang (S)	C	Ewha Womans University	Department of Physics						
Hoil Kim (G)	C	Pohang University of Science and Technology	Physics						
Jun Sung Kim (S)	C	Pohang University of Science and Technology	Physics						

# Appendix VI – User Proposals

Participants (Name, Role, Org., Dept.)		Funding Sources (Funding Agency, Division, Award #)		Proposal #	Proposal Title	Discipline	Exp. #	Days Used	
ChangIl Kwon (G)	C	Pohang University of Science and Technology	Physics						
Myeong jun Oh (G)	C	Kyungpook National University	Physics						
Jong Mok Ok (G)	C	Pohang University of Science and Technology	Physics						
Woun Kang (S)	PI	Ewha Womans University	Department of Physics	National Research Foundation of Korea	<b>P09531</b>	Study of metallic state of (TMTTF) <sub>2</sub> Br - Unified model for the quasi-one-dimensional conductors	Condensed Matter Physics	1	5.85
YounJung Jo (S)	C	Kyungpook National University	Physics						
Hoil Kim (G)	C	Pohang University of Science and Technology	Physics						
Jun Sung Kim (S)	C	Pohang University of Science and Technology	Physics						
ChangIl Kwon (G)	C	Pohang University of Science and Technology	Physics						
Toshikazu Nakamura (S)	C	Institute for Molecular Science	Chemistry						
Toshihito Osada (S)	C	University of Tokyo	Department of Physics in Extreme Conditions						
Toshihiro Taen (S)	C	University of Tokyo	The Institute for Solid State Physics						
Kazumasa Iida (S)	PI	Nagoya University	Dep. of Crystalline Materials Science, Graduate School of Engineering	Nagoya University	<b>P09519</b>	High field transport properties of LnFeAs(O,F) coated conductors	Condensed Matter Physics	1	0.89
Gianmarco Bovone (P)	C	National High Magnetic Field Laboratory (NHMFL)	Applied Superconductivity Center						
Jens Haenisch (S)	C	Karlsruhe Institute of Technology	Institute for Technica Physics						
Jan Jaroszynski (S)	C	National High Magnetic Field Laboratory (NHMFL)	CMS						
Sven Meyer (G)	C	Karlsruhe Institute of Technology	Institute for Technical Physics						
Chiara Tarantini (S)	C	National High Magnetic Field Laboratory (NHMFL)	Applied Superconductivity Center						

# Appendix VI – User Proposals

		Participants (Name, Role, Org., Dept.)		Funding Sources (Funding Agency, Division, Award #)			Proposal #	Proposal Title	Discipline	Exp. #	Days Used
John Durrell (S)	PI	University of Cambridge	Engineering Department	The Boeing Company			P08509	Crack Resistant High Temperature Bulk Superconductors	Engineering	1	7
Mark Ainslie (P)	C	University of Cambridge	Engineering	Engineering and Physical Sciences Research Council (UK)							
David Cardwell (S)	C	University of Cambridge	Engineering Department								
Tony Dennis (T)	C	University of Cambridge	Engineering								
Eric Hellstrom (S)	C	National High Magnetic Field Laboratory (NHMFL)	Applied Superconductivity Center								
Jan Jaroszynski (S)	C	National High Magnetic Field Laboratory (NHMFL)	CMS								
Kysen Palmer (G)	C	University of Cambridge	Engineering								
Jordan Rush (G)	C	University of Cambridge	Engineering								
Jan Srpcic (G)	C	University of Cambridge	Engineering								
Jun Zhu (S)	PI	Pennsylvania State University	Physics	DOD - Department of Defense	U.S. Navy	N00014-11-1-0730	P08487	Symmetry breaking and kink states in few-layer graphene nanostructures	Condensed Matter Physics	1	7
Jing Li (G)	C	Pennsylvania State University	Physics								
Zhenxi Yin (G)	C	Pennsylvania State University	Physics								
Kresimir Rupnik (S)	PI	Louisiana State University	Chemistry Department	NHMFL UCGP - User Collaboration Grants Program		227000-520-022742	P08452	Ultrafast Polarization Phase Selective (PPS) Studies: Areas of Fundamental Significance to Biochemistry/Biophysics	Biology, Biochemistry, Biophysics	1	1.9
Stephen McGill (S)	C	National High Magnetic Field Laboratory (NHMFL)	Condensed Matter Science	Louisiana State University							
Philip Moll (S)	PI	ETH Zürich	MPI Chemical Physics of Solids	No other support (i.e. this experiment is entirely supported by NHMFL users services via its core grant)			P08435	Field Induced density wave in CeRhIn5 and CeCoIn5	Condensed Matter Physics	1	5.25
Fedor Balakirev (S)	C	National High Magnetic Field Laboratory (NHMFL)	PFF								
Luis Balicas (S)	C	National High Magnetic Field Laboratory (NHMFL)	Condensed Matter Experiment								

# Appendix VI – User Proposals

		Participants (Name, Role, Org., Dept.)		Funding Sources (Funding Agency, Division, Award #)			Proposal #	Proposal Title	Discipline	Exp. #	Days Used
Bertram Batlogg (S)	C	ETH Zürich	Physics								
Eric Bauer (S)	C	Los Alamos National Laboratory	MST-10								
Audrey Grockowiak (S)	C	National High Magnetic Field Laboratory (NHMFL)	DC Field/CMS								
Toni Helm (P)	C	Max Planck Institute	Physics of Quantum materials								
Filip Ronning (S)	C	Los Alamos National Laboratory	MPA-CMMS								
Kent Shirer (P)	C	Max Planck Institute for Chemical Physics of Solids	Microstructured Quantum Matter and Physics of Quantum Materials								
Stan Tozer (S)	C	National High Magnetic Field Laboratory (NHMFL)	Physics								
Kenneth Knappenberger (S)	PI	Florida State University (FSU)	Chemistry and Biochemistry	NSF - National Science Foundation	CHE – Division of Chemistry	1150259	<b>P08433</b>	State-Resolved Electron Dynamics in Structurally Precise Metal Clusters	Chemistry, Geochemistry	2	14
Patrick Herbert (G)	C	Florida State University (FSU)	Chemistry and Biochemistry								
Stephen McGill (S)	C	National High Magnetic Field Laboratory (NHMFL)	Condensed Matter Science								
Utsab Mitra (G)	C	Florida State University (FSU)	Chemistry and Biochemistry								
Dmitry Smirnov (S)	PI	National High Magnetic Field Laboratory (NHMFL)	Instrumentation & Operations	No other support (i.e. this experiment is entirely supported by NHMFL users services via its core grant)			<b>P08432</b>	Magneto-Raman spectroscopy of correlated electron systems	Condensed Matter Physics	2	14
Ryan Baumbach (S)	C	National High Magnetic Field Laboratory (NHMFL)	CMS								
Zhengguang Lu (G)	C	National High Magnetic Field Laboratory (NHMFL)	Physics								
Jonathan Ludwig (G)	C	National High Magnetic Field Laboratory (NHMFL)	CMS								
Seonghill Moon (G)	C	National High Magnetic Field Laboratory (NHMFL)	Physics								

# Appendix VI – User Proposals

Participants (Name, Role, Org., Dept.)		Funding Sources (Funding Agency, Division, Award #)			Proposal #	Proposal Title	Discipline	Exp. #	Days Used		
Komalavalli Thirunavukkuarasu (S)	C	National High Magnetic Field Laboratory (NHMFL)	EMR								
James Hone (S)	PI	Columbia University	Mechanical Engineering	NSF - National Science Foundation	DMR – Division of Materials Research	1157490	<b>P08430</b>	Magneto-transport in van der Waals Heterostructures	Condensed Matter Physics	4	24.41
Abhinandan Antony (G)	C	Columbia University	Mechanical Engineering	DOE - Department of Energy	Office of Science - BES – Basic Energy Sciences		DE-SC0016703				
Luis Balicas (S)	C	National High Magnetic Field Laboratory (NHMFL)	Condensed Matter Experiment								
Avishai Benyamini (P)	C	Columbia University	Mechanical Engineering								
Shaowen Chen (G)	C	Columbia University	Applied Physics and Applied Mathematics								
Xu Cui (G)	C	Columbia University	Mechanical Engineering								
Cory Dean (S)	C	City College of New York	Physics								
Benjamin Hunt (S)	C	Carnegie Mellon University	Physics								
Younghun Jung (P)	C	Columbia University	Mechanical Engineering								
Philip Kim (S)	C	Harvard University	Department of Physics								
Youngduck Kim (P)	C	Columbia University	Mechanical Engineering								
Jia Li (P)	C	Columbia University	Physics								
Daniel Rhodes (P)	C	Columbia University	Mechanical Engineering								
Rebeca Ribeiro Palau (P)	C	Columbia University	Physics								
Dongjea Seo (G)	C	Columbia University	Mechanical engineering								
En-Min Shih (G)	C	Columbia University	Physics								
Cheng Tan (G)	C	Columbia University	Electrical Engineering								
Lei Wang (G)	C	Columbia University	Mechanical Engineering								
Matthew Yankowitz (P)	C	Columbia University	Physics								



# Appendix VI – User Proposals

	Participants (Name, Role, Org., Dept.)		Funding Sources (Funding Agency, Division, Award #)				Proposal #	Proposal Title	Discipline	Exp. #	Days Used
Yihang Zeng (G)	C	Columbia University	Physics								
Yoram Dagan (S)	PI	Tel-Aviv University	School of Physics and Astronomy	Israel Science Foundation			<b>P08423</b>	Superconducting-ferroelectric oxide interface	Condensed Matter Physics	1	7
David Graf (S)	C	National High Magnetic Field Laboratory (NHMFL)	DC Field CMS								
Eran Maniv (G)	C	Tel-Aviv University	Physics								
Ju-Hyun Park (S)	C	National High Magnetic Field Laboratory (NHMFL)	Instrumentation & Operations, User Support								
Lloyd Engel (S)	PI	National High Magnetic Field Laboratory (NHMFL)	CMS	DOE - Department of Energy	Office of Science - BES – Basic Energy Sciences	DE-FG02-05ER46212	<b>P08420</b>	Microwave spectroscopy of exotic electron solids in wide quantum wells	Condensed Matter Physics	1	7
Jeremy Curtis (G)	C	University of Alabama, Birmingham	Physics								
Matthew Freeman (G)	C	National High Magnetic Field Laboratory (NHMFL)	Condensed Matter Science								
Anthony Hatke (P)	C	National High Magnetic Field Laboratory (NHMFL)	CMS								
Loren Pfeiffer (S)	C	Princeton University	Electrical Engineering								
Mansour Shayegan (S)	C	Princeton University	Department of Electrical Engineering								
Lu Li (S)	PI	University of Michigan	Physics	DOE - Department of Energy	Office of Science - BES – Basic Energy Sciences	DE-SC0008110	<b>P08418</b>	Interaction-Driven Topological Materials	Condensed Matter Physics	6	36.6
Tomoya Asaba (G)	C	University of Michigan	Physics	NSF - National Science Foundation		ECCS-1307744					
Lu Chen (G)	C	University of Michigan	Physics	DOD - Department of Defense	U.S. Navy	N00014-15-1-2382					
Ben Lawson (G)	C	University of Michigan	Physics								
Yuji Matsuda (S)	C	Kyoto University	Physics								
Johnpierre Paglione (S)	C	University of Maryland, College Park	Center for Nanophysics and Advanced Materials, Department of Physics								

# Appendix VI – User Proposals

		Participants (Name, Role, Org., Dept.)		Funding Sources (Funding Agency, Division, Award #)			Proposal #	Proposal Title	Discipline	Exp. #	Days Used
Colin Tinsman (G)	C	University of Michigan	Physics								
Ziji Xiang (P)	C	University of Michigan	Physics								
Denis Karaiskaj (S)	PI	University of South Florida	Physics	DOE - Department of Energy	Office of Science - BES – Basic Energy Sciences	DE-SC0012635	<b>P08413</b>	Exploring Two-dimensional Electron systems at Extreme Magnetic Fields with Optical and Terahertz 2DFT Spectroscopy	Condensed Matter Physics	2	7.35
Timothy Cox (G)	C	University of South Florida	Dept of Physics	NSF - National Science Foundation	DMR – Division of Materials Research	DMR-1409473					
David Hilton (S)	C	University of Alabama, Birmingham	Physics								
Jagannath Paul (G)	C	University of South Florida	Applied Physics								
Jie Shan (S)	C	Pennsylvania State University	Physics								
Christopher Stevens (G)	C	University of South Florida	Physics								
Haoxiang Zhang (P)	C	University of South Florida	Physics								
Dragana Popovic (S)	PI	National High Magnetic Field Laboratory (NHMFL)	Condensed Matter Science / Experimental	NSF - National Science Foundation	DMR – Division of Materials Research	1307075	<b>P08411</b>	Magnetotransport in Underdoped Cuprates	Condensed Matter Physics	6	37.81
Paul Baity (G)	C	National High Magnetic Field Laboratory (NHMFL)	Physics	Supported by NHMFL users services via its core grant							
Genda Gu (S)	C	Brookhaven National Laboratory									
Bal Pokharel (G)	C	National High Magnetic Field Laboratory (NHMFL)	Physics								
Takao Sasagawa (S)	C	Tokyo Institute of Technology	Materials and Structures Laboratory								
Zhenzhong Shi (P)	C	National High Magnetic Field Laboratory (NHMFL)	CMS, NHMFL								
Lily Stanley (G)	C	National High Magnetic Field Laboratory (NHMFL)	Physics and CMS, NHMFL								

# Appendix VI – User Proposals

Participants (Name, Role, Org., Dept.)		Funding Sources (Funding Agency, Division, Award #)			Proposal #	Proposal Title	Discipline	Exp. #	Days Used		
Jasminka Terzic (P)	C	University of Colorado, Boulder	Physics								
John Tranquada (S)	C	Brookhaven National Laboratory	Condensed Matter Physics and Materials Science								
Peide Ye (S)	PI	Purdue University	School of Electrical and Computer Engineering	NSF - National Science Foundation	DMR – Division of Materials Research	1157490	<b>P08405</b>	Studies of Novel Two Dimensional Material Phosphorene	Condensed Matter Physics	4	27
Yuchen Du (G)	C	Purdue University	Electrical Engineering								
Gang Qiu (G)	C	Purdue University	Electrical and Computer Engineering								
Hong Zhou (G)	C	Purdue University	Electrical Computer Engineering								
Sung Seok Seo (S)	PI	University of Kentucky	Physics	NSF - National Science Foundation	DMR – Division of Materials Research	1454200	<b>P08343</b>	Magneto-transport properties of layered iridate (A <sub>2</sub> IrO <sub>4</sub> ) epitaxial thin-films	Condensed Matter Physics	1	6
Gang Cao (S)	C	University of Colorado, Boulder	Department of Physics.								
Eun Sang Choi (S)	C	National High Magnetic Field Laboratory (NHMFL)	Physics Department								
John Connell (G)	C	University of Kentucky	Physics and Astronomy								
John Gruenewald (G)	C	University of Kentucky	Physics and Astronomy								
Bongju Kim (P)	C	Seoul National University	Physics								
Jun Sung Kim (S)	C	Pohang University of Science and Technology	Physics								
Woojin Kim (G)	C	Seoul National University	Physics and Astronomy								
Oleksandr Korneta (G)	C	University of Kentucky	Department of Physics and Astronomy								
Tae Won Noh (S)	C	Seoul National University	School of Physics								
Justin Thompson (G)	C	University of Kentucky	Physics and Astronomy								
Louis Taillefer (S)	PI	University of Sherbrooke	Physics	Canada Research			<b>P08341</b>	Pressure studies of high-temperature	Condensed Matter Physics	1	5.29

# Appendix VI – User Proposals

		Participants (Name, Role, Org., Dept.)		Funding Sources (Funding Agency, Division, Award #)			Proposal #	Proposal Title	Discipline	Exp. #	Days Used
Amirreza Ataei (G)	C	University of Sherbrooke	Physics					superconductors			
Sven Badoux (P)	C	University of Sherbrooke	Physics								
Clément Collignon (G)	C	University of Sherbrooke	Physics								
Nicolas Doiron-Leyraud (S)	C	University of Sherbrooke	Physics								
Anaëlle Legros (G)	C	University of Sherbrooke	Physics								
Maude Lizaire (G)	C	University of Sherbrooke	Physics								
Rui-Rui Du (S)	PI	Rice University	Physics and Astronomy	NSF - National Science Foundation	DMR – Division of Materials Research	DMR1508644	<b>P08338</b>	Quantum Transport of Exciton Condensates in InAs/GaSb Quantum Wells	Condensed Matter Physics	2	13.17
Tingxin Li (P)	C	Rice University	Phys & Astro	Welch Foundation							
Jie Zhang (G)	C	Rice University	Phys & Astro								
Po Zhang (G)	C	Peking University	International Center for Quantum Materials								
Joseph Checkelsky (S)	PI	Massachusetts Institute of Technology	Physics	MIT			<b>P08337</b>	Interplay of Magnetism and Topological Phases	Condensed Matter Physics	2	11.49
Aravind Devarakonda (G)	C	Massachusetts Institute of Technology	Physics								
Takehito Suzuki (P)	C	Massachusetts Institute of Technology	Department of Physics								
Linda Ye (G)	C	Massachusetts Institute of Technology	Physics								
James Hone (S)	PI	Columbia University	Mechanical Engineering	No other support (i.e. this experiment is entirely supported by NHMFL users services via its core grant)	DMR – Division of Materials Research		<b>P08332</b>	Quantum Oscillations in Two-Dimensional Transition Metal Dichalcogenide Heterostructures	Condensed Matter Physics	1	5.78
Shaowen Chen (G)	C	Columbia University	Applied Physics and Applied Mathematics								
Xu Cui (G)	C	Columbia University	Mechanical Engineering								
Cory Dean (S)	C	City College of New York	Physics								

# Appendix VI – User Proposals

Participants (Name, Role, Org., Dept.)		Funding Sources (Funding Agency, Division, Award #)		Proposal #	Proposal Title	Discipline	Exp. #	Days Used	
Carlos Forsythe (G)	C	Columbia University	Physics						
Martin Gustafsson (P)	C	Columbia University	Physics						
Benjamin Hunt (S)	C	Carnegie Mellon University	Physics						
Philip Kim (S)	C	Harvard University	Department of Physics						
Youngduck Kim (P)	C	Columbia University	Mechanical Engineering						
Jia Li (P)	C	Columbia University	Physics						
Xiaomeng Liu (G)	C	Harvard University	Physics						
Daniel Rhodes (P)	C	Columbia University	Mechanical Engineering						
Rebeca Ribeiro Palau (P)	C	Columbia University	Physics						
Dongjea Seo (G)	C	Columbia University	Mechanical engineering						
En-Min Shih (G)	C	Columbia University	Physics						
Lei Wang (G)	C	Columbia University	Mechanical Engineering						
Matthew Yankowitz (P)	C	Columbia University	Physics						
Malte Grosche (S)	PI	University of Cambridge	Cavendish Laboratory	EPSRC of the United Kingdom	<b>P08323</b>	Quantum oscillations in Mott insulators metallised under high pressure	Condensed Matter Physics	2	12.45
Jordan Baglo (P)	C	University of Cambridge	Cavendish Laboratory						
Hui Chang (G)	C	University of Cambridge	Cavendish Laboratory						
William Coniglio (S)	C	National High Magnetic Field Laboratory (NHMFL)							
Sven Friedemann (S)	C	University of Bristol	Department of Physics						
Audrey Grockowiak (S)	C	National High Magnetic Field Laboratory (NHMFL)	DC Field/CMS						
Pascal Reiss (P)	C	University of Oxford	Clarendon Laboratory						
Konstantin Semeniuk (G)	C	University of Cambridge	Cavendish Laboratory						
Stan Tozer (S)	C	National High Magnetic Field Laboratory (NHMFL)	Physics						

# Appendix VI – User Proposals

Participants (Name, Role, Org., Dept.)		Funding Sources (Funding Agency, Division, Award #)			Proposal #	Proposal Title	Discipline	Exp. #	Days Used		
Guillaume Gervais (S)	PI	McGill University	Physics department	CRSNG (canada)	P08310	Berry's Phase in 2D Condensed Matter Systems	Condensed Matter Physics	2	11.33		
Nicolas Doiron-Leyraud (S)	C	University of Sherbrooke	Physics	Cifar (Canada)							
Nicholas Hemsworth (G)	C	McGill University	Electrical and Computer Engineering	FRQNT (Qc)							
Matei Petrescu (G)	C	McGill University	Physics								
Thomas Szkopek (S)	C	McGill University	Electrical and Computer Engineering								
Taichi Terashima (S)	PI	National Institute for Materials Science	Nano-quantum Transport Group	NIMS, Japan	P07187	de Haas-van Alphen measurements on exotic superconductors and metals	Condensed Matter Physics	1	5.63		
Eun Sang Choi (S)	C	National High Magnetic Field Laboratory (NHMFL)	Physics Department								
David Graf (S)	C	National High Magnetic Field Laboratory (NHMFL)	DC Field CMS								
Naoki Kikugawa (S)	C	National Institute for Materials Science	Superconducting Properties Unit								
Pablo Jarillo-Herrero (S)	PI	Massachusetts Institute of Technology	Physics	DOE - Department of Energy	Office of Science - BES – Basic Energy Sciences	de-sc0001819	P07185	High-Field Quantum Transport in Twisted Bilayer Graphene	Condensed Matter Physics	2	12.44
Yuan Cao (G)	C	Massachusetts Institute of Technology	Physics								
Jason Luo (G)	C	Massachusetts Institute of Technology	Physics								
M.A. Mueed (G)	C	Princeton University	Electrical Engineering								
Sergey Suchalkin (S)	PI	State University of New York at Stony Brook	Electrical and Computer Engineering	NSF - National Science Foundation	DMR – Division of Materials Research	DMR1160843	P07180	Magneto-spectroscopy of metamorphic InAsSb narrow band semiconductors	Condensed Matter Physics	1	6
Gregory Belenky (S)	C	State University of New York at Stony Brook	Electrical and Computer Engineering								
Gela Kipshidze (S)	C	State University of New York at Stony Brook	Electrical and Computer Engineering								

# Appendix VI – User Proposals

Participants (Name, Role, Org., Dept.)		Funding Sources (Funding Agency, Division, Award #)			Proposal #	Proposal Title	Discipline	Exp. #	Days Used		
Jonathan Ludwig (G)	C	National High Magnetic Field Laboratory (NHMFL)	CMS								
Serge Luryi (S)	C	State University of New York at Stony Brook	Electrical and Computer Engineering								
Seongphill Moon (G)	C	National High Magnetic Field Laboratory (NHMFL)	Physics								
Dmitry Smirnov (S)	C	National High Magnetic Field Laboratory (NHMFL)	Instrumentation & Operations								
Tony Heinz (S)	PI	Stanford University	Department of Physics	NSF - National Science Foundation	DMR – Division of Materials Research	1420634	<b>P07177</b>	Magneto-Optical Study of Atomically Thin Transition Metal Dichalcogenide Crystals	Condensed Matter Physics	1	14
You Lai (G)	C	National High Magnetic Field Laboratory (NHMFL)	Physics								
Zhiqiang Li (S)	C	SiChuan University	Physics								
Jonathan Ludwig (G)	C	National High Magnetic Field Laboratory (NHMFL)	CMS								
Eric Yue Ma (P)	C	Stanford University	Applied Physics								
Stephen McGill (S)	C	National High Magnetic Field Laboratory (NHMFL)	Condensed Matter Science								
Dmitry Smirnov (S)	C	National High Magnetic Field Laboratory (NHMFL)	Instrumentation & Operations								
Xiaoxiao Zhang (G)	C	Columbia University	Physics								
Mansour Shayegan (S)	PI	Princeton University	Department of Electrical Engineering	NSF - National Science Foundation	DMR – Division of Materials Research	1157490	<b>P02480</b>	Magnetotransport measurements in low-dimensional, interacting electronic systems	Condensed Matter Physics	2	11.71
Kirk Baldwin (S)	C	Princeton University	Electrical Engineering								
Hao Deng (G)	C	Princeton University	Electrical Engineering								
Sukret Hasdemir (G)	C	Princeton University	Electrical Engineering								
Md Shafayat Hossain (G)	C	Princeton University	EE								
Dobromir	C	Princeton University	ELE								

# Appendix VI – User Proposals

Participants (Name, Role, Org., Dept.)		Funding Sources (Funding Agency, Division, Award #)		Proposal #	Proposal Title	Discipline	Exp. #	Days Used			
Kamburov (G)											
Yang Liu (G)	C	Princeton University	ELE								
Mueed M.A. (G)	C	Princeton University	Electrical engineering								
Meng Ma (G)	C	Princeton University	Electrical Engineering								
M.A. Mueed (G)	C	Princeton University	Electrical Engineering								
Loren Pfeiffer (S)	C	Princeton University	Electrical Engineering								
Ken West (S)	C	Princeton University	Princeton Institute for the Science and Technology of Materials								
Zhigang Jiang (S)	PI	Georgia Institute of Technology	School of Physics	DOE - Department of Energy	Office of Science - BES – Basic Energy Sciences	DE-FG02-07ER46451	<b>P02425</b>	Quantum Transport and Infrared Spectroscopy of Graphene	Condensed Matter Physics	1	1
Yuxuan Jiang (G)	C	Georgia Institute of Technology	School of Physics	NSF - National Science Foundation	DMR – Division of Materials Research	DMR-0820382					
Dmitry Smirnov (S)	C	National High Magnetic Field Laboratory (NHMFL)	Instrumentation & Operations								
Jeremy Yang (G)	C	Georgia Institute of Technology	School of Physics								
Janice Musfeldt (S)	PI	University of Tennessee, Knoxville	Department of Chemistry	DOE - Department of Energy	Office of Science - BES – Basic Energy Sciences	DE-FG02-01ER-45885	<b>P02415</b>	High field spectroscopy of materials	Chemistry, Geochemistry	1	5.26
Sang Wook Cheong (S)	C	Rutgers University, New Brunswick	Physics and Astronomy								
Shiyu Fan (G)	C	University of Tennessee, Knoxville	Physics								
Zhiqiang Li (S)	C	SiChuan University	Physics								
David Mandrus (S)	C	University of Tennessee, Knoxville	Materials Science and Engineering								
Stephen McGill (S)	C	National High Magnetic Field Laboratory (NHMFL)	Condensed Matter Science								
Julia Mundy (P)	C	University of	Materials								



# Appendix VI – User Proposals

Participants (Name, Role, Org., Dept.)		Funding Sources (Funding Agency, Division, Award #)			Proposal #	Proposal Title	Discipline	Exp. #	Days Used		
R. Ramesh (S)	C	California, Berkeley University of California, Berkeley	Department of Materials Science and Engineering								
Darrell Schlom (S)	C	Cornell University	Materials Science								
John Singleton (S)	C	National High Magnetic Field Laboratory (NHMFL)	Physics								
Dmitry Smirnov (S)	C	National High Magnetic Field Laboratory (NHMFL)	Instrumentation & Operations								
Kevin Smith (G)	C	University of Tennessee, Knoxville	Chemistry								
Haidong Zhou (S)	C	University of Tennessee, Knoxville	Physics and Astronomy								
Lloyd Engel (S)	PI	National High Magnetic Field Laboratory (NHMFL)	CMS	DOE - Department of Energy	Office of Science - BES – Basic Energy Sciences	DE-FG02-05ER46212	<b>P02375</b>	Broadband microwave studies of high quality graphene in high magnetic field	Condensed Matter Physics	1	6
Jeremy Curtis (G)	C	University of Alabama, Birmingham	Physics								
Cory Dean (S)	C	City College of New York	Physics								
Matthew Freeman (G)	C	National High Magnetic Field Laboratory (NHMFL)	Condensed Matter Science								
Philip Kim (S)	C	Harvard University	Department of Physics								
Philip Kim (S)	PI	Harvard University	Department of Physics	DOE - Department of Energy	Office of Science	DEFG02-05ER46215	<b>P02330</b>	Tunable Quantum Hall in Graphene Heterostructures	Condensed Matter Physics	2	9.61
Cory Dean (S)	C	City College of New York	Physics								
Carlos Forsythe (G)	C	Columbia University	Physics								
Katie Huang (G)	C	Harvard University	Physics								
Luis Jauregui (P)	C	Harvard University	College of Science								
Andrew Joe (G)	C	Harvard University	Physics								
Gil-Ho Lee (P)	C	Harvard University	Physics								
Jia Li (P)	C	Columbia University	Physics								

# Appendix VI – User Proposals

Participants (Name, Role, Org., Dept.)		Funding Sources (Funding Agency, Division, Award #)			Proposal #	Proposal Title	Discipline	Exp. #	Days Used	
Xiaomeng Liu (G)	C	Harvard University	Physics							
Kateryna Pistunova (U)	C	Harvard University	Physics							
Ke Wang (P)	C	Harvard University	Physics							
Lei Wang (G)	C	Columbia University	Mechanical Engineering							
Cory Dean (S)	PI	City College of New York	Physics	Supported by NHMFL users services via its core grant		<b>P02272</b>	Resistively detected NMR study of spin polarization in 13C graphene	Condensed Matter Physics	2	13.36
Paul Cadden-Zimansky (S)	C	Bard College	Physics	NSF - National Science Foundation	DMR – Division of Materials Research	1507788				
Shaowen Chen (G)	C	Columbia University	Applied Physics and Applied Mathematics							
Scott Dietrich (P)	C	Columbia University	Physics							
Lloyd Engel (S)	C	National High Magnetic Field Laboratory (NHMFL)	CMS							
Carlos Forsythe (G)	C	Columbia University	Physics							
David Graf (S)	C	National High Magnetic Field Laboratory (NHMFL)	DC Field CMS							
Benjamin Hunt (S)	C	Carnegie Mellon University	Physics							
Philip Kim (S)	C	Harvard University	Department of Physics							
Jia Li (P)	C	Columbia University	Physics							
Xiaomeng Liu (G)	C	Harvard University	Physics							
Arneil Reyes (S)	C	National High Magnetic Field Laboratory (NHMFL)	Condensed Matter Science							
Daniel Rhodes (P)	C	Columbia University	Mechanical Engineering							
Rebeca Ribeiro Palau (P)	C	Columbia University	Physics							
En-Min Shih (G)	C	Columbia University	Physics							
Adam Tsen (P)	C	Columbia University	Physics							
Lei Wang (G)	C	Columbia University	Mechanical Engineering							

# Appendix VI – User Proposals

Participants (Name, Role, Org., Dept.)		Funding Sources (Funding Agency, Division, Award #)		Proposal #	Proposal Title	Discipline	Exp. #	Days Used
Matthew Yankowitz (P)	C	Columbia University	Physics					
Andrea Young (S)	C	University of California, Santa Barbara	Physics					
Yihang Zeng (G)	C	Columbia University	Physics					
<b>Total Proposals:</b>							<b>Experiments:</b>	<b>Days:</b>
164							301	1,780.58

\* = A new PI for the reporting year.

PI = Principal Investigator; C = Collaborator

S = Senior Personnel; P = Postdoc; G = Graduate Student; U = Undergraduate Student; T = Technician, programmer

# Appendix VI – User Proposals

Participants (Name, Role, Org., Dept.)		Funding Sources (Funding Agency, Division, Award #)			Proposal #	Proposal Title	Discipline	Exp. #	Days Used		
Komalavalli Thirunavukkuarasu (S)	PI *	National High Magnetic Field Laboratory (NHMFL)	EMR	DOD - Department of Defense	U.S. Navy	5346	<b>P17534</b>	Magneto-optical spectroscopy on functional materials: Multiferroics and beyond	Condensed Matter Physics	1	1
Zhengguang Lu (G)	C	National High Magnetic Field Laboratory (NHMFL)	Physics								
David Mandrus (S)	C	University of Tennessee, Knoxville	Materials Science and Engineering								
Dmitry Smirnov (S)	C	National High Magnetic Field Laboratory (NHMFL)	Instrumentation & Operations								
Russell Maier (P)	PI *	National Institute of Standards and Technology	Materials Measurement Laboratory	National Institute of Standards and Technology			<b>P17488</b>	High Frequency EPR Characterization of Mn and Fe-Related Point Defects in the Perovskite Structure	Condensed Matter Physics	2	5
Andrew Ozarowski (S)	C	National High Magnetic Field Laboratory (NHMFL)	EMR								
Johan van Tol (S)	C	National High Magnetic Field Laboratory (NHMFL)	EMR								
Hannah Shafaat (S)	PI *	Ohio State University	Chemistry and Biochemistry	The Ohio State University			<b>P17478</b>	Advanced EPR investigations of spin-coupled Mn/Fe intermediates formed during oxygen activation in a heterobimetallic oxidase	Biology, Biochemistry, Biophysics	1	6
Samuel Greer (G)	C	National High Magnetic Field Laboratory (NHMFL)	Chemistry								
Stephen Hill (S)	C	National High Magnetic Field Laboratory (NHMFL)	EMR								
Jonathan Marbey (G)	C	National High Magnetic Field Laboratory (NHMFL)	EMR								
Effie Miller (G)	C	Ohio State University	Ohio State Biochemistry Program								

# Appendix VI – User Proposals

Participants (Name, Role, Org., Dept.)		Funding Sources (Funding Agency, Division, Award #)			Proposal #	Proposal Title	Discipline	Exp. #	Days Used
Enrique Colacio (S)	PI	University of Granada	Inorganic Chemistry	No other support (i.e. this experiment is entirely supported by NHMFL users services via its core grant)	P17454	High-frequency and -field EPR of 2D Co(II) SMMs with different hexacoordinated Co(II) ions.	Chemistry, Geochemistry	1	7
Jurek Krzystek (S)	C	National High Magnetic Field Laboratory (NHMFL)	Condensed Matter Science						
Maciej Witwicki (P)	PI *	University of Wroclaw	Faculty of Chemistry	Wroclaw University, Poland	P17418	High-Field EPR of Unusual Complexes of Semiquinone Radicals	Chemistry, Geochemistry	3	22
Julia Jezierska (S)	C	University of Wroclaw	Chemistry						
Andrew Ozarowski (S)	C	National High Magnetic Field Laboratory (NHMFL)	EMR						
Lloyd Lumata (S)	PI	University of Texas, Dallas	Physics	The Robert A. Welch Foundation	P17389	EPR studies of free radical mixtures used in dynamic nuclear polarization	Biology, Biochemistry, Biophysics	2	20
Peter Niedbalski (G)	C	University of Texas, Dallas	Department of Physics						
Christopher Parish (G)	C	University of Texas, Dallas	Physics						
Likai Song (S)	C	National High Magnetic Field Laboratory (NHMFL)	EMR						
Markus Enders (S)	PI *	Heidelberg University	Chemistry	No other support (i.e. this experiment is entirely supported by NHMFL users services via its core grant)	P17384	Unpaired electron spin properties of light d-block metal compounds	Chemistry, Geochemistry	2	4
Jurek Krzystek (S)	C	National High Magnetic Field Laboratory (NHMFL)	Condensed Matter Science						
Andrew Ozarowski (S)	C	National High Magnetic Field Laboratory (NHMFL)	EMR						
Joshua Telser (S)	C	Roosevelt University	Chemistry						
Joan Cano (S)	PI	University of Valencia	Instituto de Ciencia Molecular	No other support (i.e. this experiment is entirely supported by NHMFL users services via its core	P17379	Building quantum gates and quantum computer by assembling mononuclear single-molecule magnets based on Co(II)	Chemistry, Geochemistry	2	10

# Appendix VI – User Proposals

Participants (Name, Role, Org., Dept.)			Funding Sources (Funding Agency, Division, Award #)		Proposal #	Proposal Title	Discipline	Exp. #	Days Used	
Miguel Julve (S)	C	University of Valencia	Inorganic Chemistry				and other 3d transition metal ions. In pursuit of new physics in spintronics			
Jurek Krzystek (S)	C	National High Magnetic Field Laboratory (NHMFL)	Condensed Matter Science							
Francesc Lloret (S)	C	University of Valencia	Institut de Ciència Molecular (ICMOL). Chemistry							
Julia Vallejo (G)	C	University of Valencia								
Brian Hoffman (S)	PI *	Northwestern University	Chemistry	NIH - National Institutes of Health	GM111097	P17350	In vivo Mn2+ Speciation	Biology, Biochemistry, Biophysics	1	6
Ajay Aharma (P)	C	Northwestern University	Chemistry	DOD - Department of Defense						
Andrew Ozarowski (S)	C	National High Magnetic Field Laboratory (NHMFL)	EMR							
Sergei Zvyagin (S)	PI	Helmholtz-Zentrum Dresden-Rossendorf	EPR	No other support (i.e. this experiment is entirely supported by NHMFL users services via its core grant)		P17345	Spin dynamics and magnetic properties of spin systems with competing magnetic interactions	Condensed Matter Physics	1	5
Sang Wook Cheong (S)	C	Rutgers University, New Brunswick	Physics and Astronomy							
Marcelo Jaime (S)	C	National High Magnetic Field Laboratory (NHMFL)	Physics							
Jurek Krzystek (S)	C	National High Magnetic Field Laboratory (NHMFL)	Condensed Matter Science							
Chris Landee (S)	C	Clark University	Department of Physics							
David Mandrus (S)	C	University of Tennessee, Knoxville	Materials Science and Engineering							
Stephen Nagler (S)	C	Oak Ridge National Laboratory								

# Appendix VI – User Proposals

Participants (Name, Role, Org., Dept.)		Funding Sources (Funding Agency, Division, Award #)			Proposal #	Proposal Title	Discipline	Exp. #	Days Used		
Jeffrey Reimer (S)	PI *	University of California, Berkeley	Chem and BioM Engineering	DOE - Department of Energy	Office of Science - BES – Basic Energy Sciences	DE-SC0001015	<b>P17340</b>	Mapping Metals in Mixed-Metal Metal-Organic Frameworks	Chemistry, Geochemistry	1	7
Andrew Ozarowski (S)	C	National High Magnetic Field Laboratory (NHMFL)	EMR								
Jun Xu (P)	C	University of California, Berkeley	Chemical and Biomolecular Engineering								
Andrew Ozarowski (S)	PI	National High Magnetic Field Laboratory (NHMFL)	EMR	No other support (i.e. this experiment is entirely supported by NHMFL users services via its core grant)			<b>P17321</b>	Calibration And Maintenance Of The 15/17 T Epr Instrument Instruments	Magnets, Materials, Testing, Instrumentation	1	13
Andrew Ozarowski (S)	PI	National High Magnetic Field Laboratory (NHMFL)	EMR	No other support (i.e. this experiment is entirely supported by NHMFL users services via its core grant)			<b>P17320</b>	Calibration And Maintenance Of The Mössbauer Instruments	Magnets, Materials, Testing, Instrumentation	1	34
Sebastian Stoian (S)	C	University of Idaho	Chemistry								
Christos Lampropoulos (S)	PI	University of North Florida	Chemistry	NSF - National Science Foundation	DMR – Division of Materials Research	1429428	<b>P16307</b>	HF-EPR of Molecular Magnet-based Materials Under Ambient & Elevated Pressures	Chemistry, Geochemistry	1	1
Thorson Bastien (U)	C	University of North Florida	Chemistry	NSF - National Science Foundation	DMR – Division of Materials Research	1626332					
Jacob Bryant (U)	C	University of North Florida	Chemistry								
Chloe Chicola (U)	C	University of North Florida	Chemistry								
Victor da Cruz Pinha Barbosa (U)	C	University of North Florida	Chemistry								
Emily Frederick (U)	C	University of North Florida	Physics								
Michelle Glaze (U)	C	University of North Florida	Chemistry								
Stephen Hill (S)	C	National High Magnetic Field Laboratory (NHMFL)	EMR								

# Appendix VI – User Proposals

Participants (Name, Role, Org., Dept.)		Funding Sources (Funding Agency, Division, Award #)			Proposal #	Proposal Title	Discipline	Exp. #	Days Used		
Kai Lister (U)	C	University of North Florida	Chemistry								
Devon Loughran (T)	C	University of North Florida	Physics								
Shannon McPherson (U)	C	University of North Florida	Chemistry								
Pere Miro Ramirez (S)	C	University of North Florida	Chemistry								
Andrew Ozarowski (S)	C	National High Magnetic Field Laboratory (NHMFL)	EMR								
Jose Pagan (U)	C	University of North Florida	Physics								
Alexandra Patron (U)	C	University of North Florida	Chemistry								
Jennifer Ruliffson (U)	C	University of North Florida	Department of Chemistry								
Joel Serrano (U)	C	University of North Florida	Chemistry								
Steven Stone (U)	C	University of North Florida	Chemistry								
Eric Williams (U)	C	University of North Florida	Chemistry								
Michael Shatruk (S)	PI	National High Magnetic Field Laboratory (NHMFL)	Department of Chemistry	NSF - National Science Foundation	DMR – Division of Materials Research	1507233	<b>P16302</b>	Investigation of Magnetic Phase Transitions in Itinerant Magnets CuFe <sub>2-x</sub> CoxGe <sub>2</sub>	Biology, Biochemistry, Biophysics	2	44
Sebastian Stoian (S)	C	University of Idaho	Chemistry								
Zachary Tener (G)	C	Florida State University (FSU)	Chemistry and Biochemistry								
Jianfeng Cai (S)	PI	University of South Florida	Department of Chemistry	NIH - National Institutes of Health	NIGMS – National Institute of General Medical Sciences	GM112652	<b>P16301</b>	Multi-frequency EPR analysis of AApeptides with membranes	Biology, Biochemistry, Biophysics	2	19
Enrique del Barco (S)	PI	University of Central Florida	Physics	University of Central Florida			<b>P16298</b>	Spintronics with Antiferromagnetic Insulators	Condensed Matter Physics	1	6
Priyanka Vaidya (G)	C	University of Central Florida	Physics Department								
Johan van Tol (S)	C	National High Magnetic Field Laboratory (NHMFL)	EMR								



# Appendix VI – User Proposals

		Participants (Name, Role, Org., Dept.)		Funding Sources (Funding Agency, Division, Award #)			Proposal #	Proposal Title	Discipline	Exp. #	Days Used
Ellis Reinherz (S)	PI	Dana-Farber Cancer Institute	Medicine	NIH - National Institutes of Health	NIAID – National Institute of Allergy and Infectious Diseases	AI126901	<b>P16241</b>	EPR analysis of HIV-1 MPER segment for optimized vaccine design	Biology, Biochemistry, Biophysics	6	72.5
Likai Song (S)	C	National High Magnetic Field Laboratory (NHMFL)	EMR								
Jurij Koruza (P)	PI *	Technical University of Darmstadt	Materials Science	Deutsche Forschungsgemeinschaft			<b>P16240</b>	High-Field EPR Investigations of Acceptor-Doped Lead-Free Piezoelectric Ceramics	Magnets, Materials, Testing, Instrumentation	2	10
Emre Erdem (P)	C	University of Freiburg	Chemistry								
Jan Schultheiß (G)	C	Technical University of Darmstadt	Material Science								
Dmitry Smirnov (S)	PI	National High Magnetic Field Laboratory (NHMFL)	Instrumentation & Operations	DOE - Department of Energy	Office of Science - BES – Basic Energy Sciences		<b>P16234</b>	Electrical and magnetic field control of optical processes in mono- and few-layer transition metal dichalcogenides	Condensed Matter Physics	3	13
Luis Jauregui (P)	C	Harvard University	College of Science								
Zhigang Jiang (S)	C	Georgia Institute of Technology	School of Physics								
Andrew Joe (G)	C	Harvard University	Physics								
Philip Kim (S)	C	Harvard University	Department of Physics								
Zhengguang Lu (G)	C	National High Magnetic Field Laboratory (NHMFL)	Physics								
Seongphill Moon (G)	C	National High Magnetic Field Laboratory (NHMFL)	Physics								
Kateryna Pistunova (U)	C	Harvard University	Physics								
Stergios Piligkos (S)	PI	University of Copenhagen	Department of Chemistry	University of Copenhagen			<b>P16138</b>	Pulsed HF-EPR of Yb(trensral)	Condensed Matter Physics	3	12
Stephen Hill (S)	C	National High Magnetic Field Laboratory	EMR								

# Appendix VI – User Proposals

Participants (Name, Role, Org., Dept.)		Funding Sources (Funding Agency, Division, Award #)			Proposal #	Proposal Title	Discipline	Exp. #	Days Used		
Dorsa Komijani (G)	C	(NHMFL) National High Magnetic Field Laboratory (NHMFL)	Physics								
Srinivasa Rao Singamaneni (S)	PI	University of Texas, El Paso	Physics	University of Texas		<b>P16127</b>	High Frequency Electron Spin Resonance (ESR) Studies on MoS2 and Co nanostructures	Condensed Matter Physics	4	18	
Johan van Tol (S)	C	National High Magnetic Field Laboratory (NHMFL)	EMR								
Olga Vassilyeva (S)	PI	Taras Shevchenko National University of Kyiv	Chemistry	Research Foundation of National Taras Shevchenko University		<b>P16086</b>	New Schiff base heterometallics towards magnetic materials and catalysts	Chemistry, Geochemistry	8	36	
Roman Boca (S)	C	Slovak Technical University	Inorganic Chemistry								
Katerina Kasyanova (G)	C	Taras Shevchenko National University of Kyiv	Chemistry								
Andrew Ozarowski (S)	C	National High Magnetic Field Laboratory (NHMFL)	EMR								
Svitlana Petrusenko (S)	C	Taras Shevchenko National University of Kyiv	Chemistry								
Oleg Stetsiuk (U)	C	Taras Shevchenko National University of Kyiv	Inorganic Chemistry								
Fengyuan Yang (S)	PI *	Ohio State University	Physics	NSF - National Science Foundation	DMR – Division of Materials Research	GRT00042291	<b>P16081</b>	High Frequency Ferromagnetic/Antiferromagnetic Resonance of thin films	Magnets, Materials, Testing, Instrumentation	4	23.5
P. Hammel (S)	C	Ohio State University	Physics								
Inhee Lee (P)	C	Ohio State University	Physics								
Denis Pelekhov (S)	C	Ohio State University	Physics								
Johan van Tol (S)	C	National High Magnetic Field Laboratory (NHMFL)	EMR								
Zhigang Jiang (S)	PI	Georgia Institute of Technology	School of Physics	DOE - Department of Energy	Office of Science - BES – Basic	DE-FG02- 07ER46451	<b>P16079</b>	Magneto-infrared Spectroscopy Study of Emerging Topological Materials with Layered Structures	Condensed Matter Physics	3	7

# Appendix VI – User Proposals

Participants (Name, Role, Org., Dept.)				Funding Sources (Funding Agency, Division, Award #)			Proposal #	Proposal Title	Discipline	Exp. #	Days Used
Yuxuan Jiang (G)	C	Georgia Institute of Technology	School of Physics								
Dmitry Smirnov (S)	C	National High Magnetic Field Laboratory (NHMFL)	Instrumentation & Operations								
Johan van Tol (S)	C	National High Magnetic Field Laboratory (NHMFL)	EMR								
Joshua Telser (S)	PI	Roosevelt University	Chemistry	NSF - National Science Foundation	CHE – Division of Chemistry	1361654	<b>P16069</b>	High- Frequency and- Field EPR Studies of Complexes of Complexes of Groups 5 – 9 Ions with Unusual Ligands	Chemistry, Geochemistry	4	23
Lauren Grant (G)	C	Pennsylvania State University	Chemistry								
Samuel Greer (G)	C	National High Magnetic Field Laboratory (NHMFL)	Chemistry								
Trevor Hayton (S)	C	University of California, Santa Barbara	Chemistry and Biochemistry								
Anne Hickey (G)	C	Indiana University	Chemistry								
Jurek Krzystek (S)	C	National High Magnetic Field Laboratory (NHMFL)	Condensed Matter Science								
Jorge Martinez (G)	C	Indiana University	Chemistry								
Daniel Mindiola (S)	C	Pennsylvania State University	Chemistry								
Andrew Ozarowski (S)	C	National High Magnetic Field Laboratory (NHMFL)	EMR								
Jeremy Smith (S)	C	Indiana University	Chemistry								
Sebastian Stoian (S)	C	University of Idaho	Chemistry								
Benjamin Wicker (S)	C	University of Pikeville	Chemistry								
Kate Ross (S)	PI	Colorado State University	Physics	NSF - National Science Foundation	DMR – Division of Materials Research	1611217	<b>P16064</b>	Probing signatures of low-dimensional magnetism in layered honeycomb compound BaCo <sub>2</sub> (PO <sub>4</sub> ) <sub>2</sub> using	Condensed Matter Physics	1	2

# Appendix VI – User Proposals

Participants (Name, Role, Org., Dept.)		Funding Sources (Funding Agency, Division, Award #)			Proposal #	Proposal Title	Discipline	Exp. #	Days Used		
Harikrishnan Nair (P)	C	Colorado State University	Department of Physics				high frequency electron paramagnetic resonance spectroscopy				
Srinivasa Rao Singamaneni (S)	C	University of Texas, El Paso	Physics								
Johan van Tol (S)	C	National High Magnetic Field Laboratory (NHMFL)	EMR								
Vladimir Arion (S)	PI	University of Vienna	Chemistry	No other support (i.e. this experiment is entirely supported by NHMFL users services via its core grant)		<b>P16054</b>	High-Frequency and –Field EPR Spectroscopy on Manganese(III) Complexes with Schiff Bases Containing a Disiloxane Unit	Chemistry, Geochemistry	1	1	
Jurek Krzystek (S)	C	National High Magnetic Field Laboratory (NHMFL)	Condensed Matter Science								
Joshua Telsler (S)	C	Roosevelt University	Chemistry								
Linda Doerrler (S)	PI	Boston University	Chemistry Department	NSF - National Science Foundation	CHE – Division of Chemistry	CHE-1362550	<b>P16034</b>	Fluorinated Alkoxide Donors and their Ligand Field Effects	Chemistry, Geochemistry	9	63
Jessica Elinburg (G)	C	Boston University	Chemistry								
Jacob Henebry (U)	C	Boston University	Chemistry								
Emily Norwine (U)	C	Boston University	Chemistry								
Andrew Ozarowski (S)	C	National High Magnetic Field Laboratory (NHMFL)	EMR								
Sebastian Stoian (S)	C	University of Idaho	Chemistry								
Peter Qin (S)	PI	University of Southern California	Chemistry	NSF - National Science Foundation	CHE – Division of Chemistry	1213673	<b>P16033</b>	DNA target recognition by CRISPR-Cas studied using site-directed spin labeling	Biology, Biochemistry, Biophysics	2	15
Johannes McKay (P)	C	Keysight Technologies	MMIC Microwave								
Likai Song (S)	C	National High Magnetic Field Laboratory (NHMFL)	EMR								
Frederic Mentink (S)	PI *	National High Magnetic Field Laboratory (NHMFL)	NMR Division	No other support (i.e. this experiment is entirely supported by NHMFL users services via its core			<b>P16032</b>	Towards more efficient Magic Angle Spinning – Dynamic Nuclear Polarization at 14 T	Chemistry, Geochemistry	4	12

# Appendix VI – User Proposals

Participants (Name, Role, Org., Dept.)		Funding Sources (Funding Agency, Division, Award #)		Proposal #	Proposal Title	Discipline	Exp. #	Days Used	
Tim Cross (S)	C	National High Magnetic Field Laboratory (NHMFL)	NHMFL/Chemistry & Biochemistry						
Gael De Paepe (S)	C	The French Alternative Energies and Atomic Energy Commission	Institute for Nanoscience and Cryogenics						
Sabine Hediger (S)	C	The French Alternative Energies and Atomic Energy Commission	Institute for Nanoscience and Cryogenics						
Johannes McKay (P)	C	Keysight Technologies	MMIC Microwave						
Johan van Tol (S)	C	National High Magnetic Field Laboratory (NHMFL)	EMR						
Shimon Vega (S)	C	Weizmann Institute of Science	Physical Chemistry						
Joanna Long (S)	PI	University of Florida	Biochemistry & Molecular Biology	University of Florida	P14952	Study of electron relaxation times of radicals under conditions relevant for hyperpolarization techniques	Biology, Biochemistry, Biophysics	2	11
Bimala Lama (P)	C	University of Florida	Biochemistry and Molecular Biology						
Johannes McKay (P)	C	Keysight Technologies	MMIC Microwave						
Frederic Mentink (S)	C	National High Magnetic Field Laboratory (NHMFL)	NMR Division						
Adam Smith (P)	C	University of Florida	Chemistry						
Johan van Tol (S)	C	National High Magnetic Field Laboratory (NHMFL)	EMR						
Xiaoling Wang (P)	C	National High Magnetic Field Laboratory (NHMFL)	NMR						

# Appendix VI – User Proposals

Participants (Name, Role, Org., Dept.)		Funding Sources (Funding Agency, Division, Award #)			Proposal #	Proposal Title	Discipline	Exp. #	Days Used		
Jianjun Pan (S)	PI	University of South Florida	Physics	No other support (i.e. this experiment is entirely supported by NHMFL users services via its core grant)		P14941	Interactions of Protein Aggregates with Lipid Membranes Defined by Multi-Frequency EPR EMR Facility	Biology, Biochemistry, Biophysics	6	40.5	
Likai Song (S)	C	National High Magnetic Field Laboratory (NHMFL)	EMR								
William DeGrado (S)	PI	University of California, San Francisco	Department of Pharmaceutical Chemistry	NIH - National Institutes of Health	NIGMS – National Institute of General Medical Sciences	GM054616	P14935	Multi-Frequency EPR Analysis of Catalytic Helix Bundles	Biology, Biochemistry, Biophysics	1	3
Likai Song (S)	C	National High Magnetic Field Laboratory (NHMFL)	EMR								
Shao-Qing Zhang (P)	C	University of California, San Francisco	Department of Pharmaceutical Chemistry								
Stephen Hill (S)	PI	National High Magnetic Field Laboratory (NHMFL)	EMR	No other support (i.e. this experiment is entirely supported by NHMFL users services via its core grant)		P14910	Instrument development and maintenance of the w-band pulsed EPR spectrometer HiPER	Magnets, Materials, Testing, Instrumentation	2	36	
Nandita Abhyankar (G)	C	Florida State University (FSU)	Chemistry								
Johannes McKay (P)	C	Keysight Technologies	MMIC Microwave								
Likai Song (S)	C	National High Magnetic Field Laboratory (NHMFL)	EMR								
Tina Salguero (S)	PI	University of Georgia	Chemistry	DOE - Department of Energy	Office of Science - BES – Basic Energy Sciences	DE-SC0008065	P14904	Moessbauer Spectroscopy on Bulk and Nanosheet BaFeSi4O10	Chemistry, Geochemistry	3	9
Darrah Johnson-McDaniel (G)	C	University of Georgia	Chemistry								
Andrew Ozarowski (S)	C	National High Magnetic Field Laboratory (NHMFL)	EMR								

# Appendix VI – User Proposals

Participants (Name, Role, Org., Dept.)		Funding Sources (Funding Agency, Division, Award #)			Proposal #	Proposal Title	Discipline	Exp. #	Days Used		
Sebastian Stoian (S)	C	University of Idaho	Chemistry								
Harry Dorn (S)	PI	Virginia Polytechnic Institute and State University	Chemistry	No other support (i.e. this experiment is entirely supported by NHMFL users services via its core grant)	<b>P14889</b>	EPR studies on the effects of gadolinium-based fullerenes on DNP enhancements at cryogenic temperatures	Biology, Biochemistry, Biophysics	1	3		
Zhehong Gan (S)	C	National High Magnetic Field Laboratory (NHMFL)	NHMFL								
Stephen Hill (S)	C	National High Magnetic Field Laboratory (NHMFL)	EMR								
Ivan Hung (S)	C	National High Magnetic Field Laboratory (NHMFL)	CIMAR/NMR								
Johannes McKay (P)	C	Keysight Technologies	MMIC Microwave								
Frederic Mentink (S)	C	National High Magnetic Field Laboratory (NHMFL)	NMR Division								
Johan van Tol (S)	C	National High Magnetic Field Laboratory (NHMFL)	EMR								
Xiaoling Wang (P)	C	National High Magnetic Field Laboratory (NHMFL)	NMR								
Johan van Tol (S)	PI	National High Magnetic Field Laboratory (NHMFL)	EMR	Supported by NHMFL users services via its core grant	<b>P14847</b>	Instrumentation Testing	Magnets, Materials, Testing, Instrumentation	7	71.5		
Thierry Dubroca (P)	C	National High Magnetic Field Laboratory (NHMFL)	EMR	NHMFL UCGP - User Collaboration Grants Program							
Elizabeth Stroupe (S)	PI	Florida State University (FSU)	BIOLOGICAL SCIENCE	NSF - National Science Foundation	MCB – Division of Molecular and Cellular	MCB-1149763	<b>P14840</b>	Iron-sulfur cluster function in Escherichia coli Sulfite Reductase	Biology, Biochemistry, Biophysics	1	1

# Appendix VI – User Proposals

Participants (Name, Role, Org., Dept.)			Funding Sources (Funding Agency, Division, Award #)			Proposal #	Proposal Title	Discipline	Exp. #	Days Used	
Biosciences											
Marisa Cepeda (U)	C	Florida State University (FSU)	Chemistry								
Jurek Krzystek (S)	C	National High Magnetic Field Laboratory (NHMFL)	Condensed Matter Science								
Joscha Nehrkorn (P)	PI	Florida State University (FSU)	National High Magnetic Field Laboratory	University of Washington			<b>P14837</b>	Determination of Zero-Field Splitting of Novel Molecular Nanomagnets with Electron Paramagnetic Resonance at Multiple High Frequencies	Condensed Matter Physics	3	13
Samuel Greer (G)	C	National High Magnetic Field Laboratory (NHMFL)	Chemistry								
Jurek Krzystek (S)	C	National High Magnetic Field Laboratory (NHMFL)	Condensed Matter Science								
Stefan Stoll (S)	C	University of Washington	Chemistry								
Linda Columbus (S)	PI	University of Virginia	Department of Chemistry	NIH - National Institutes of Health	NIGMS – National Institute of General Medical Sciences	2R01GM087828-06	<b>P14820</b>	Structure determination of the Opa60-CEACAM complex	Biology, Biochemistry, Biophysics	1	7
Marissa Kieber (G)	C	University of Virginia	Chemistry								
Eugenio Coronado (S)	PI	University of Valencia	Chemistry	NSF - National Science Foundation	DMR – Division of Materials Research	DMR1309463	<b>P14813</b>	Enhancement in coherence time using clock transitions in a Ho(III) molecular nanomagnet	Magnets, Materials, Testing, Instrumentation	2	9
Stephen Hill (S)	C	National High Magnetic Field Laboratory (NHMFL)	EMR	NSF - National Science Foundation	DMR – Division of Materials Research	DMR1157490					
Dorsa Komijani (G)	C	National High Magnetic Field Laboratory (NHMFL)	Physics	DOD - Department of Defense	U.S. Air Force						
Jonathan Marbey (G)	C	National High Magnetic Field Laboratory (NHMFL)	EMR	Ministry of Economy and competitiveness-Spanish National Research Council		MAT-2014-56143-R					
				European Research Council (ECR)							



# Appendix VI – User Proposals

Participants (Name, Role, Org., Dept.)				Funding Sources (Funding Agency, Division, Award #)			Proposal #	Proposal Title	Discipline	Exp. #	Days Used
				Ministry of Economy and Competitiveness (Spanish National Research Council)	CTQ2014-52758-P						
				Ministry of Economy and Competitiveness (Spanish National Research Council)	MDM-2015-0538						
				Generalitat Valenciana (Regional Government of Valencia)							
Junichiro Kono (S)	PI	Rice University	Electrical and Computer Engineering	DOE - Department of Energy	Office of Science - BES – Basic Energy Sciences	DE-FG02-06ER46308	<b>P14803</b>	Conduction Electron Spin Resonance in Metallic Carbon Nanotubes	Condensed Matter Physics	1	3
Dmitry Smirnov (S)	C	National High Magnetic Field Laboratory (NHMFL)	Instrumentation & Operations								
Komalavalli Thirunavukkuarasu (S)	C	National High Magnetic Field Laboratory (NHMFL)	EMR								
Brian Hales (S)	PI	Louisiana State University	Chemistry	No other support (i.e. this experiment is entirely supported by NHMFL users services via its core grant)			<b>P14782</b>	High-Field EPR Investigations of the P-cluster in the Nitrogenase MoFe Protein	Biology, Biochemistry, Biophysics	2	23
Johannes McKay (P)	C	Keysight Technologies	MMIC Microwave								
Likai Song (S)	C	National High Magnetic Field Laboratory (NHMFL)	EMR								
Johan van Tol (S)	C	National High Magnetic Field Laboratory (NHMFL)	EMR								
Sufei Shi (S)	PI	* Rensselaer Polytechnic Institute	Chemical and Biological Engineering	Rensselaer Polytechnic Institute			<b>P14775</b>	Magneto-transport of van der Waals Heterostructure	Engineering	3	24
Likai Li (G)	C	Fudan University	Physics								
Zhipeng Li (P)	C	Rensselaer Polytechnic	Chemical and Biological								

# Appendix VI – User Proposals

Participants (Name, Role, Org., Dept.)		Funding Sources (Funding Agency, Division, Award #)		Proposal #	Proposal Title	Discipline	Exp. #	Days Used	
Zhengguang Lu (G)	C	Institute National High Magnetic Field Laboratory (NHMFL)	Engineering Physics						
Ju-Hyun Park (S)	C	National High Magnetic Field Laboratory (NHMFL)	Instrumentation & Operations, User Support						
Dmitry Smirnov (S)	C	National High Magnetic Field Laboratory (NHMFL)	Instrumentation & Operations						
Tianmeng Wang (G)	C	Rensselaer Polytechnic Institute	Chemical and Biological Engineering						
Likai Song (S)	PI	National High Magnetic Field Laboratory (NHMFL)	EMR	No other support (i.e. this experiment is entirely supported by NHMFL users services via its core grant)	<b>P14730</b>	Development of high-field and pulsed EPR methods in biological applications	Biology, Biochemistry, Biophysics	6	118.5
Sankalpa Chakraborty (G)	C	Florida State University (FSU)	Department of Biological Sciences						
Inhee Lee (P)	C	Ohio State University	Physics						
Johannes McKay (P)	C	Keysight Technologies	MMIC Microwave						
Nathan Peek (G)	C	National High Magnetic Field Laboratory (NHMFL)	Chemistry and Biochemistry						
Denis Pelekhov (S)	C	Ohio State University	Physics						
Sylvain Bertainia (S)	PI	Institut Matériaux Microélectronique Nanosciences de Provence (IM2NP)	Nanoscience	CNRS - PICS CoDyLow	<b>P14729</b>	Pulsed EPR in Mn <sup>2+</sup> -doped Perovskite-Like MOF DMZnF	Condensed Matter Physics	1	4
Nandita Abhyankar (G)	C	Florida State University (FSU)	Chemistry						
Naresh Dalal (S)	C	National High Magnetic Field Laboratory (NHMFL)	Chemistry						

# Appendix VI – User Proposals

Participants (Name, Role, Org., Dept.)		Funding Sources (Funding Agency, Division, Award #)			Proposal #	Proposal Title	Discipline	Exp. #	Days Used		
Jurek Krzystek (S)	C	National High Magnetic Field Laboratory (NHMFL)	Condensed Matter Science								
Ziling Xue (S)	PI	University of Tennessee, Knoxville	Chemistry	NSF - National Science Foundation	CHE – Division of Chemistry	CHE-1633870	<b>P13617</b>	Probing Molecular Magnetism by Infrared and Raman Spectroscopies in Magnetic Fields	Chemistry, Geochemistry	1	7
Zhengguang Lu (G)	C	National High Magnetic Field Laboratory (NHMFL)	Physics								
Clay Mings (G)	C	University of Tennessee, Knoxville	Chemistry								
Duncan Moseley (G)	C	University of Tennessee, Knoxville	Chemistry								
Dmitry Smirnov (S)	C	National High Magnetic Field Laboratory (NHMFL)	Instrumentation & Operations								
Shelby Stavretis (G)	C	University of Tennessee, Knoxville	Chemistry								
Komalavalli Thirunavukkuarasu (S)	C	National High Magnetic Field Laboratory (NHMFL)	EMR								
Roberto De Guzman (S)	PI	University of Kansas	Molecular Biosciences	NIH - National Institutes of Health	NIAID – National Institute of Allergy and Infectious Diseases	AI074856	<b>P12563</b>	EPR studies of protein-protein interactions in the assembly of bacterial nanoinjectors	Biology, Biochemistry, Biophysics	1	11
Likai Song (S)	C	National High Magnetic Field Laboratory (NHMFL)	EMR								
Luis Balicas (S)	PI *	National High Magnetic Field Laboratory (NHMFL)	Condensed Matter Experiment	DOE - Department of Energy	Office of Science - BES – Basic Energy Sciences	DE-SC0002613	<b>P11512</b>	Exploring the electronic properties of Weyl semimetal candidates	Condensed Matter Physics	1	3
Yu Che Chiu (G)	C	National High Magnetic Field Laboratory	Condensed Matter Sciences								

# Appendix VI – User Proposals

		Participants (Name, Role, Org., Dept.)		Funding Sources (Funding Agency, Division, Award #)			Proposal #	Proposal Title	Discipline	Exp. #	Days Used
Johan van Tol (S)	C	(NHMFL) National High Magnetic Field Laboratory (NHMFL)	EMR								
Lucio Frydman (S)	PI	Weizmann Institute of Science	Dept. Chemical Physics	NSF - National Science Foundation	CHE – Division of Chemistry	NSF MRI Project CHE-1229170	<b>P11492</b>	EPR and NMR Spectroscopy of Small Molecules in Low Viscosity Solvents	Biology, Biochemistry, Biophysics	3	27
Adewale Akinfaderin (G)	C	Florida State University (FSU)	Physics	NSF - National Science Foundation	CHE – Division of Chemistry	CHE1612700					
Thierry Dubroca (P)	C	National High Magnetic Field Laboratory (NHMFL)	EMR								
Stephen Hill (S)	C	National High Magnetic Field Laboratory (NHMFL)	EMR								
Johannes McKay (P)	C	Keysight Technologies	MMIC Microwave								
Johan van Tol (S)	C	National High Magnetic Field Laboratory (NHMFL)	EMR								
Sungsool Wi (S)	C	National High Magnetic Field Laboratory (NHMFL)	NMR								
Wojciech Grochala (S)	PI	University of Warsaw	CENT	NCN, Polish National Science Center			<b>P11479</b>	HF-ESR Characteristics of Paramagnetic Ag(2+) Sites in Several Prototypical Fluoride Systems	Condensed Matter Physics	3	17
Stephen Hill (S)	C	National High Magnetic Field Laboratory (NHMFL)	EMR	NCN, Polish National Science Center							
Zoran Mazej (S)	C	Jozef Stefan Institute	Department of Inorganic Chemistry and Technology EMR	NCN, Polish National Science Center							
Andrew Ozarowski (S)	C	National High Magnetic Field Laboratory (NHMFL)									
R. Britt (S)	PI	University of California, Davis	Chemistry	NSF - National Science Foundation	CHE – Division of	1213699	<b>P11468</b>	High Field EPR on Cobalt Oxide Water Oxidation Electrocatalysts	Chemistry, Geochemistry	4	40

# Appendix VI – User Proposals

Participants (Name, Role, Org., Dept.)			Funding Sources (Funding Agency, Division, Award #)		Proposal #	Proposal Title	Discipline	Exp. #	Days Used
Chemistry									
Johannes McKay (P)	C	Keysight Technologies	MMIC Microwave						
Johan van Tol (S)	C	National High Magnetic Field Laboratory (NHMFL)	EMR						
Zhenxing Wang (S)	PI	Huazhong University of Science and Technology	Wuhan National High Magnetic Field Center, China	No other support (i.e. this experiment is entirely supported by NHMFL users services via its core grant)	<b>P11462</b>	High Field EPR Measurements on Cobalt Based Single Ion Magnets	Chemistry, Geochemistry	3	25
Jasleen Bindra (G)	C	National High Magnetic Field Laboratory (NHMFL)	Department of Chemistry and Biochemistry						
Jurek Krzystek (S)	C	National High Magnetic Field Laboratory (NHMFL)	Condensed Matter Science						
Zhongwen Ouyang (S)	C	Huazhong University of Science and Technology	Wuhan National High Magnetic Field Center						
Andrew Ozarowski (S)	C	National High Magnetic Field Laboratory (NHMFL)	EMR						
Johan van Tol (S)	C	National High Magnetic Field Laboratory (NHMFL)	EMR						
Kevin Huang (S)	PI	University of South Carolina	College of Engineering and Computing	No other support (i.e. this experiment is entirely supported by NHMFL users services via its core grant)	<b>P09504</b>	High-temperature Solid-state NMR Studies of Ionic Conduction Mechanisms in Low-cost and Rare-earth-free Superior Fast Oxide-ion Conductor Sr <sub>3</sub> -3xNa3xSi3O9-1.5x	Chemistry, Geochemistry	4	30
Kevin Huang (S)	C	University of South Carolina	College of Engineering and Computing						
Likai Song (S)	C	National High Magnetic Field Laboratory (NHMFL)	EMR						

# Appendix VI – User Proposals

Participants (Name, Role, Org., Dept.)		Funding Sources (Funding Agency, Division, Award #)		Proposal #	Proposal Title	Discipline	Exp. #	Days Used		
Alberto Ghirri (S)	PI	CNR Institute Nanoscience	Centro S3	Consiglio Nazionale delle Ricerche (Italy)		P08473	Study of decoherence and relaxation in single-crystals of molecular nanomagnets	Condensed Matter Physics	4	33
Marco Affronte (S)	C	University of Modena and Reggio Emilia	Istituto Nazionale di fisica della materia	DOD - Department of Defense	U.S. Air Force					
Claudio Bonizzoni (G)	C	University of Pavia	Physics, Informatics and Mathematics	Italian Ministry of Research FIRB project						
Dorsa Komijani (G)	C	National High Magnetic Field Laboratory (NHMFL)								
Johannes McKay (P)	C	Keysight Technologies	MMIC Microwave							
Johan van Tol (S)	C	National High Magnetic Field Laboratory (NHMFL)								
Dmitry Smirnov (S)	PI	National High Magnetic Field Laboratory (NHMFL)	Instrumentation & Operations	No other support (i.e. this experiment is entirely supported by NHMFL users services via its core grant)		P08432	Magneto-Raman spectroscopy of correlated electron systems	Condensed Matter Physics	2	4
Zhengguang Lu (G)	C	National High Magnetic Field Laboratory (NHMFL)	Physics							
Seonghill Moon (G)	C	National High Magnetic Field Laboratory (NHMFL)	Physics							
Komalavalli Thirunavukkuarasu (S)	C	National High Magnetic Field Laboratory (NHMFL)								
Lloyd Lumata (S)	PI	University of Texas, Dallas	Physics	DOD - Department of Defense	U.S. Army	P08395	X- and W-band Electron Spin Resonance (ESR) relaxation properties of DNP free radical polarizing agents	Chemistry, Geochemistry	3	18.5
Andhika Kiswandhi (P)	C	University of Texas, Dallas	Department of Physics							
Peter Niedbalski (G)	C	University of Texas, Dallas	Department of Physics							
Likai Song (S)	C	National High Magnetic Field Laboratory								

# Appendix VI – User Proposals

Participants (Name, Role, Org., Dept.)		Funding Sources (Funding Agency, Division, Award #)		Proposal #	Proposal Title	Discipline	Exp. #	Days Used	
(NHMFL)									
Naresh Dalal (S)	PI	National High Magnetic Field Laboratory (NHMFL)	Chemistry	DFG (Deutsche Forschungsgemeinschaft-German Research Foundation)	<b>P08311</b>	High Field and High Frequency EPR Study of Coordinately Unsaturated Transition Metal Complexes with Possible SMM Behavior	Chemistry, Geochemistry	1	6
Jasleen Bindra (G)	C	National High Magnetic Field Laboratory (NHMFL)	Department of Chemistry and Biochemistry						
John Haddock (G)	C	Florida State University (FSU)	Chemistry						
Mohindar Seehra (S)	C	West Virginia University	Department of Physics and Astronomy						
Johan van Tol (S)	C	National High Magnetic Field Laboratory (NHMFL)	EMR						
Malgorzata Holynska (S)	PI	Philipps University Marburg	Chemistry	German Research Council (DFG)	<b>P07291</b>	New magnetic materials based on bridged manganese complexes	Chemistry, Geochemistry	1	2
George Christou (S)	C	University of Florida	Chemistry	Philipps University Marburg					
Adeline Fournet (G)	C	University of Florida	Chemistry						
Stephen Hill (S)	C	National High Magnetic Field Laboratory (NHMFL)	EMR						
Maria Korabik (S)	C	University of Wroclaw	Chemistry						
Muhandis Muhandis (G)	C	National High Magnetic Field Laboratory (NHMFL)	EMR						
Andrew Ozarowski (S)	C	National High Magnetic Field Laboratory (NHMFL)	EMR						
Clemens Pietzonka (T)	C	Philipps University Marburg	Chemistry						
Katye Poole (G)	C	University of Florida	Chemistry						
Dejan Premuzic (G)	C	Philipps University Marburg	Chemistry						
Ellis Reinherz (S)	PI	Dana-Farber Cancer Institute	Medicine	Bill and Melinda Gates Foundation	<b>P07139</b>	Structural analysis of HIV-1 MPER segment from clade C viruses	Biology, Biochemistry,	1	2

# Appendix VI – User Proposals

Participants (Name, Role, Org., Dept.)		Funding Sources (Funding Agency, Division, Award #)		Proposal #	Proposal Title	Discipline	Exp. #	Days Used
Likai Song (S)	C	National High Magnetic Field Laboratory (NHMFL)	EMR		using EPR	Biophysics		
<b>Total Proposals:</b>							<b>Experiments:</b>	<b>Days:</b>
61							153	1,120.00

\* = A new PI for the reporting year.

PI = Principal Investigator; C = Collaborator

S = Senior Personnel; P = Postdoc; G = Graduate Student; U = Undergraduate Student; T = Technician, programmer



# Appendix VI – User Proposals

		Participants (Name, Role, Org., Dept.)		Funding Sources (Funding Agency, Division, Award #)		Proposal #	Proposal Title	Discipline	Exp. #	Days Used
Xuan Gao (S)	PI	Case Western Reserve University	Physics	DOE - Department of Energy	Office of Science - BES – Basic Energy Sciences	<b>P17388</b>	The Effect of Spin Polarization on the Wigner Crystal to Liquid Transition in a Strongly Correlated 2D Hole System	Condensed Matter Physics	1	21
Loren Pfeiffer (S)	C	Princeton University	Electrical Engineering							
Alessandro Serafin (P)	C	University of Florida	Physics							
Ken West (S)	C	Princeton University	Princeton Institute for the Science and Technology of Materials							
Andrew Woods (P)	C	University of Florida	Physics							
Jian-sheng Xia (S)	C	University of Florida	Physics							
Liang Yin (P)	C	University of Florida	Physics							
Jurgen Smet (S)	PI *	Max Planck Institute for Solid State Research, Stuttgart, Germany	Solid State Nanophysics	Max Planck Institute for Solid State Research		<b>P16236</b>	Exotic correlated phases in oxide two-dimensional electron systems at ultra-low temperature	Biology, Biochemistry, Biophysics	1	151.5
Joseph Falson (P)	C	Max Planck Institute for Solid State Research, Stuttgart, Germany	Solid State Nanophysics							
Alessandro Serafin (P)	C	University of Florida	Physics							
Daniela Tabrea (G)	C	Max Planck Institute for Solid State Research, Stuttgart, Germany	Solid State Nanophysics							
Andrew Woods (P)	C	University of Florida	Physics							
Jian-sheng Xia (S)	C	University of Florida	Physics							
Thomas Crawford (G)	PI *	University of South Carolina	Physics and Astronomy	Smart State Center for Experimental Nanoscale Physics		<b>P16078</b>	Spin-Aharonov-Bohm Effect: Non-adiabatic Geometric Phase	Condensed Matter Physics	2	140
Ning Lu (G)	C	University of South Carolina	Department of Physics and Astronomy							
Mark Meisel (S)	C	University of Florida	Department of Physics							
Robert Hallock (S)	PI	University of Massachusetts	Department of Physics	NSF - National Science Foundation	DMR – Division of Materials Research	<b>P14962</b>	Study of Solid 4He to Very Low Temperatures	Condensed Matter Physics	2	171
Jian-sheng Xia (S)	C	University of Florida	Physics							
Geetha Balakrishnan (S)	PI	University of Warwick	Physics	EPSRC		<b>P14789</b>	Magnetic torque in a topological insulator	Condensed Matter Physics	1	20.5
Monica Ciomaga Hatnean (P)	C	University of Warwick	Physics							
Jian-sheng Xia (S)	C	University of Florida	Physics							

# Appendix VI – User Proposals

		Participants (Name, Role, Org., Dept.)		Funding Sources (Funding Agency, Division, Award #)		Proposal #	Proposal Title	Discipline	Exp. #	Days Used
Nicholas Curro (S)	PI	University of California, Davis	Physics	NSF - National Science Foundation	DMR – Division of Materials Research	<b>P14673</b>	NMR Investigation of hidden magnetism in CeRhIn5 under high pressure	Condensed Matter Physics	1	69
Blaine Bush (G)	C	University of California, Davis	Physics							
Stephen Julian (S)	PI	University of Toronto	Physics	National Research Council of Canada		<b>P14666</b>	De Haas van Alphen (dHvA) measurement on the heavy fermion system CeCoIn5.	Condensed Matter Physics	1	17
Alix McCollam (S)	C	High Field Magnet Laboratory, Radboud University	Physics							
								<b>Total Proposals:</b>	<b>Experiments:</b>	<b>Days:</b>
								7	9	590

\* = A new PI for the reporting year.

PI = Principal Investigator; C = Collaborator

S = Senior Personnel; P = Postdoc; G = Graduate Student; U = Undergraduate Student; T = Technician, programmer

# Appendix VI – User Proposals

		Participants (Name, Role, Org., Dept.)		Funding Sources (Funding Agency, Division, Award #)			Proposal #	Proposal Title	Discipline	Exp. #	Days Used
Ryan Hartman (S)	PI *	New York University	Chemistry	No other support (i.e. this experiment is entirely supported by NHMFL users services via its core grant)			P17567	Analysis of Asphaltene Deposits Precipitated on Mineral Surfaces	Chemistry, Geochemistry	1	1.5
Andrew Yen (S)	C	Nalco Energy Services	Ultra Deep Research Group								
Chris Hendrickson (S)	PI	National High Magnetic Field Laboratory (NHMFL)	Ion Cyclotron Resonance Program	NSF - National Science Foundation	DMR – Division of Materials Research	DMR 11-57490	P17524	Development of Hydrogen Deuterium Exchange Mass Spectrometry with Electron Transfer Dissociation	Chemistry, Geochemistry	1	3.5
Peilu Liu (G)	C	Florida State University (FSU)	Chemistry								
Alan Marshall (S)	C	National High Magnetic Field Laboratory (NHMFL)	ICR								
Archana Agarwal (S)	PI *	University of Utah	School of Medicine and ARUP Laboratories	No other support (i.e. this experiment is entirely supported by NHMFL users services via its core grant)			P17485	21 Tesla FT-ICR MS Analysis of Hemoglobinopathy	Biology, Biochemistry, Biophysics	1	3.5
Lidong He (G)	C	National High Magnetic Field Laboratory (NHMFL)	Chemistry								
Chris Hendrickson (S)	C	National High Magnetic Field Laboratory (NHMFL)	Ion Cyclotron Resonance Program								
Alan Marshall (S)	C	National High Magnetic Field Laboratory (NHMFL)	ICR								
Alan Rockwood (S)	C	University of Utah	School of Medicine and ARUP Laboratories								
Yun Yu (P)	PI *	University of Colorado, Boulder	Civil, Environmental, and Architectural Engineering	NSF - National Science Foundation		1512705	P17453	Transformation of Water-Extractable Soil Organic Matter from Thermally Impacted Soils	Biology, Biochemistry, Biophysics	1	1
Thomas Borch (S)	C	Colorado State University	Soil and Crop Science								

# Appendix VI – User Proposals

Participants (Name, Role, Org., Dept.)		Funding Sources (Funding Agency, Division, Award #)			Proposal #	Proposal Title	Discipline	Exp. #	Days Used	
Huan Chen (S)	C	National High Magnetic Field Laboratory (NHMFL)	Ion Cyclotron Resonance							
Amy McKenna (S)	C	National High Magnetic Field Laboratory (NHMFL)	ICR							
Fernando Rosario-Ortiz (S)	C	University of Colorado, Boulder	Environmental Engineering							
Robert Young (S)	C	Colorado State University	Soil & Crop Sciences							
Andrea Gomez-Escudero (S)	PI *	Universidad del Quindio	Chemistry	No other support (i.e. this experiment is entirely supported by NHMFL users services via its core grant)		<b>P17451</b>	Structural Comparison of Resins and Asphaltenes from Colombian Crude Oils: Characterization of Solubility Fractions by FT-ICR Mass Spectrometry	Chemistry, Geochemistry	1	2
Martha Chacon (P)	C	National High Magnetic Field Laboratory (NHMFL)	Ion Cyclotron Resonance							
Amy McKenna (S)	C	National High Magnetic Field Laboratory (NHMFL)	ICR							
Robert Spencer (S)	PI	Florida State University (FSU)	Earth, Ocean & Atmospheric Science	NSF - National Science Foundation	1603149	<b>P17440</b>	Molecular-level changes of Siberian dissolved organic carbon with irradiation and microbial processing	Chemistry, Geochemistry	1	4
Megan Behnke (G)	C	FSU	Earth, Ocean and Atmospheric Science	NSF - National Science Foundation	1500169					
Logan Krajewski (G)	C	National High Magnetic Field Laboratory (NHMFL)	Chemistry and Biochemistry							
Thomas Borch (S)	PI	Colorado State University	Soil and Crop Science	NSF - National Science Foundation	EAR1451494	<b>P17439</b>	Extraction Effects on Humic Substances Analysis	Chemistry, Geochemistry	1	4
William Bahureksa (G)	C	Colorado State University	Chemistry	NSF - National Science Foundation	CBET1512670					
Yuge Bai (G)	C	Eberhard Karls University of Tübingen	Geomicrobiology	Deutsche Forschungsgemeinschaft (DFG), Germany						

# Appendix VI – User Proposals

Participants (Name, Role, Org., Dept.)		Funding Sources (Funding Agency, Division, Award #)			Proposal #	Proposal Title	Discipline	Exp. #	Days Used	
Huan Chen (S)	C	National High Magnetic Field Laboratory (NHMFL)	Ion Cyclotron Resonance							
Andreas Kappler (S)	C	Eberhard Karls University of Tübingen	Center for Applied Geosciences							
Amy McKenna (S)	C	National High Magnetic Field Laboratory (NHMFL)	ICR							
Robert Young (S)	C	Colorado State University	Soil & Crop Sciences							
Robert Spencer (S)	PI	Florida State University (FSU)	Earth, Ocean & Atmospheric Science	NASA - National Aeronautics and Space Administration	14-TE14-0012	<b>P17426</b>	Diel variability of DOM in a sub-Arctic lake	Chemistry, Geochemistry	2	4
Ruben del Campo (G)	C	Universidad de Navarra / University of Navarra	Ecology and Hydrology							
Sarah Johnston (G)	C	National High Magnetic Field Laboratory (NHMFL)	Earth Ocean and Atmospheric Sciences							
David Podgorski (S)	C	University of New Orleans	Department of Chemistry							
Sadie Textor (U)	C	Florida State University (FSU)	Earth, Ocean, and Atmospheric Science							
Phoebe Zito (P)	C	Florida State University (FSU)	Earth, Ocean and Atmospheric Science							
Juliana D'Andrilli (S)	PI	Montana State University	Dept. of Land Resources and Environmental Sciences	Environment and Climate (CAGE), The Arctic University of Norway		<b>P17385</b>	Methane driven carbon cycling dynamics in the Arctic Ocean	Chemistry, Geochemistry	2	9.5
Benedicte Ferre (S)	C	University of Tromso, the Arctic University of Norway	Centre for Arctic Gas Hydrate							
Friederike Grundger (S)	C	University of Tromso, the Arctic University of Norway	Department of Geosciences; CAGE							

# Appendix VI – User Proposals

Participants (Name, Role, Org., Dept.)		Funding Sources (Funding Agency, Division, Award #)			Proposal #	Proposal Title	Discipline	Exp. #	Days Used
Muhammed Sert (G)	C	University of Tromso, the Arctic University of Norway	Centre for Arctic Gas Hydrate, Environment and Climate						
Anna Silyakova (S)	C	University of Tromso, the Arctic University of Norway	Centre for Arctic Gas Hydrate						
Rebecca Ware (G)	C	National High Magnetic Field Laboratory (NHMFL)	Chemistry						
Yury Tsybin (S)	PI	Spectroswiss Sarl	EPFL Innovation Park	No other support (i.e. this experiment is entirely supported by NHMFL users services via its core grant)	<b>P17383</b>	Top-down mass spectrometry analysis of monoclonal antibodies: an inter-laboratory study	Chemistry, Geochemistry	1	32.25
Lissa Anderson (S)	C	National High Magnetic Field Laboratory (NHMFL)	ICR						
Greg Blakney (S)	C	National High Magnetic Field Laboratory (NHMFL)	ICR						
Lidong He (G)	C	National High Magnetic Field Laboratory (NHMFL)	Chemistry						
Chris Hendrickson (S)	C	National High Magnetic Field Laboratory (NHMFL)	Ion Cyclotron Resonance Program						
Alan Marshall (S)	C	National High Magnetic Field Laboratory (NHMFL)	ICR						
Donald Smith (S)	C	National High Magnetic Field Laboratory (NHMFL)	ICR						
Chad Weisbrod (S)	C	National High Magnetic Field Laboratory	ICR						

# Appendix VI – User Proposals

Participants (Name, Role, Org., Dept.)		Funding Sources (Funding Agency, Division, Award #)		Proposal #	Proposal Title	Discipline	Exp. #	Days Used		
Paige Novak (S)	PI *	(NHMFL) University of Minnesota, Twin Cities	Civil, Environmental, and Geo-Engineering	NSF - National Science Foundation	CBET 1510131	P17380	Dechlorination of Chlorinated Natural Organic Matter in Salt Impacted Lakes	Engineering	1	2
Martha Chacon (P)	C	National High Magnetic Field Laboratory (NHMFL)	Ion Cyclotron Resonance							
Andrew McCabe (G)	C	University of Minnesota, Twin Cities	Civil, Environmental, and Geo-Engineering							
Hanna Temme (G)	C	University of Minnesota, Twin Cities	Civil, Environmental, and Geo-Engineering							
Zhiyong Ren (S)	PI *	University of Colorado, Boulder	Civil Environmental Architectural Engineering	Chevron Energy Company		P17328	Mechanisms of Enhanced of Petroleum Hydrocarbon Degradation by Bioelectrochemical Systems	Chemistry, Geochemistry	1	3
Huan Chen (S)	C	National High Magnetic Field Laboratory (NHMFL)	Ion Cyclotron Resonance	NSF - National Science Foundation	CAREER 1453906					
Logan Krajewski (G)	C	National High Magnetic Field Laboratory (NHMFL)	Chemistry and Biochemistry	NSF - National Science Foundation	CBET - Chemical, Bioengineering, Environmental, and Transport Systems	CBET1512705				
Lu Lu (P)	C	University of Colorado, Boulder	Civil, Environmental, and Architectural Engineering	NSF - National Science Foundation	CBET - Chemical, Bioengineering, Environmental, and Transport Systems	CBET1510682				
Amy McKenna (S)	C	National High Magnetic Field Laboratory (NHMFL)	ICR	NSF - National Science Foundation	CBET - Chemical, Bioengineering, Environmental, and Transport Systems	CBET1704921				
Fernando Rosario-Ortiz (S)	C	University of Colorado, Boulder	Environmental Engineering							
Huan Wang (P)	C	University of Colorado, Boulder	Environmental Engineering							
Yi Zuo (S)	C	Chevron, San Ramon	Environmental Unit							

# Appendix VI – User Proposals

		Participants (Name, Role, Org., Dept.)		Funding Sources (Funding Agency, Division, Award #)			Proposal #	Proposal Title	Discipline	Exp. #	Days Used
Huan Chen (S)	PI	National High Magnetic Field Laboratory (NHMFL)	Ion Cyclotron Resonance	NSF - National Science Foundation		1649741	<b>P17324</b>	Research experience for summer interns: Impact of Oil and Dispersant on the Lipid Composition of BALOs and their Oil Degrading Prey by Online Liquid Chromatography Coupled with FT-ICR MS.	Chemistry, Geochemistry	2	1.17
Ashley Deverteuil (U)	C	National High Magnetic Field Laboratory (NHMFL)	ICR	NSF - National Science Foundation		HRD 16-49741					
Grisel Fierros Romero (P)	C	Florida Agricultural and Mechanical University	School of the environment								
Rajneesh Jaswal (P)	C	Florida Agricultural and Mechanical University	School of the Environment								
Alexys Sutton (O)	C	National High Magnetic Field Laboratory (NHMFL)	NHMFL/ICR								
Henry Williams (S)	C	Florida Agricultural and Mechanical University	School of the Environment								
Donald Hunt (S)	PI *	University of Virginia	Chemistry	NIH - National Institutes of Health	NIGMS – National Institute of General Medical Sciences	GM 037537	<b>P16320</b>	Hemoglobin Characterization by FT-ICR MS	Biology, Biochemistry, Biophysics	1	2
Lissa Anderson (S)	C	National High Magnetic Field Laboratory (NHMFL)	ICR								
Elizabeth Duselis (G)	C	University of Virginia	Chemistry								
David Herold (S)	C	University of California, San Diego	Pathology								
Jeffrey Shabanowitz (S)	C	University of Virginia	Chemistry								
Pascal Boeckx (S)	PI *	Ghent University	Applied analytical and physical chemistry	Ghent University			<b>P16318</b>	Compositional controls on the sensory quality of coffee	Chemistry, Geochemistry	1	1



# Appendix VI – User Proposals

		Participants (Name, Role, Org., Dept.)		Funding Sources (Funding Agency, Division, Award #)		Proposal #	Proposal Title	Discipline	Exp. #	Days Used
David Podgorski (S)	C	University of New Orleans	Department of Chemistry							
Robert Spencer (S)	C	Florida State University (FSU)	Earth, Ocean & Atmospheric Science							
Pascal Boeckx (S)	PI *	Ghent University	Applied analytical and physical chemistry	VLIR-UOS		<b>P16300</b>	Tracing fire-derived organic components in canopy leachates from a tropical forest	Chemistry, Geochemistry	1	0.25
Marijn Bauters (G)	C	Ghent University	Applied analytical and Physical chemistry							
Travis Drake (G)	C	Florida State University (FSU)	EOAS							
Travis Drake (G)	C	Florida State University (FSU)	Department of Earth, Ocean and Atmospheric Science							
David Podgorski (S)	C	University of New Orleans	Department of Chemistry							
Robert Spencer (S)	C	Florida State University (FSU)	Earth, Ocean & Atmospheric Science							
Henderson Cleaves (S)	PI	Institute for Advanced Study	Interdisciplinary Studies	No other support (i.e. this experiment is entirely supported by NHMFL users services via its core grant)		<b>P16249</b>	High Resolution Mass Spectrometry as a Life Detection Technique forAstrobiological Applications	Chemistry, Geochemistry	3	11.5
Chaitanya Giri (P)	C	Tokyo Institute of Technology	Earth-Life Science Institute							
Piyush Khopkar (T)	C	Blue Marble Space Institute of Science	Blue Marble Space Institute of Science							
Amy McKenna (S)	C	National High Magnetic Field Laboratory (NHMFL)	ICR							
John Headley (S)	PI	Environment and Climate Change Canada	National Hydrology Research Centre	No other support (i.e. this experiment is entirely supported by NHMFL users services via its core grant)		<b>P16243</b>	Characterization of constructed treatment wetland degraded Oil sands process-affected water-NAFCs.	Chemistry, Geochemistry	2	6
Chukwuemeka Ajaero (G)	C	University of Regina	Environmental Systems Engineering							

# Appendix VI – User Proposals

Participants (Name, Role, Org., Dept.)				Funding Sources (Funding Agency, Division, Award #)			Proposal #	Proposal Title	Discipline	Exp. #	Days Used
Yuri Corilo (S)	C	National High Magnetic Field Laboratory (NHMFL)	ICR								
Monique Haakensen (S)	C	Contango Strategies	N/A								
Amy McKenna (S)	C	National High Magnetic Field Laboratory (NHMFL)	ICR								
Kerry Peru (P)	C	Environment and Climate Change Canada	Protection Research Division								
Sean Harshman (S)	PI *	Air Force Research Laboratory	711th Human Performance Wing	DOD - Department of Defense	U.S. Air Force		<b>P16238</b>	Top-down proteomic analysis of excreted sweat	Biology, Biochemistry, Biophysics	1	5.58
Lissa Anderson (S)	C	National High Magnetic Field Laboratory (NHMFL)	ICR								
William McDowell (S)	PI	University of New Hampshire	Natural Resources and the Environment	NSF - National Science Foundation		DEB 15-56603	<b>P16235</b>	Characterizing dissolved organic matter from tropical volcaniclastic streams	Chemistry, Geochemistry	1	1.5
Ashley Coble (P)	C	University of New Hampshire	Natural Resources and the Environment	NSF - National Science Foundation	EAR – Division of Earth Sciences	EAR 13-31841					
David Podgorski (S)	C	University of New Orleans	Department of Chemistry	NSF - National Science Foundation		EF 10-65286					
Bianca Rodriguez-Cardona (G)	C	University of New Hampshire	Natural Resources and the Environment	NSF - National Science Foundation		EF 14-42444					
Robert Spencer (S)	C	Florida State University (FSU)	Earth, Ocean & Atmospheric Science								
Ashley Wittrig (S)	PI *	Exxon Mobil	Analytical Sciences Laboratory	FSU Sponsored Research		RF02807	<b>P16231</b>	Characterization of petroleum samples at 21 tesla	Chemistry, Geochemistry	2	2
Amy Clingenpeel (S)	C	Exxon Mobil	Research and Development Support Services								
Anthony Mennito (S)	C	Exxon Mobil	EMRE								
Ryan Rodgers (S)	C	National High Magnetic Field Laboratory (NHMFL)	ICR								

# Appendix VI – User Proposals

Participants (Name, Role, Org., Dept.)		Funding Sources (Funding Agency, Division, Award #)			Proposal #	Proposal Title	Discipline	Exp. #	Days Used
Steven Rowland (S)	C	National High Magnetic Field Laboratory (NHMFL)	Chemistry						
Donald Smith (S)	C	National High Magnetic Field Laboratory (NHMFL)	ICR						
Brett Poulin (S)	PI *	U.S. Geological Survey	National Research Program	Idaho Power Company	<b>P16230</b>	Spatial Dependence in DOM Composition within the Hells Canyon Reservoir Complex	Chemistry, Geochemistry	3	3
David Podgorski (S)	C	University of New Orleans	Department of Chemistry	USGS National Research Program					
Robert Spencer (S)	C	Florida State University (FSU)	Earth, Ocean & Atmospheric Science						
Phoebe Zito (P)	C	Florida State University (FSU)	Earth, Ocean and Atmospheric Science						
Francois Guillemette (S)	PI *	University of Quebec at Trois-Rivières	Dept. of Environmental Sciences	Natural Science and Engineering Research Council of Canada	<b>P16207</b>	Link between molecular composition of the dissolved organic matter and the microbial community in lake vegetated versus non vegetated area	Chemistry, Geochemistry	1	1.25
Sophie Crevecoeur (P)	C	University of Quebec at Montreal	Biological sciences	Hydro-Québec					
Paul del Giorgio (S)	C	University of Quebec at Montreal	Sciences biologiques						
David Podgorski (S)	C	University of New Orleans	Department of Chemistry						
Andy Baker (S)	PI *	University of New South Wales	School of Biological, Earth and Environmental Sciences	Australian Research Council Discovery Program	<b>P16162</b>	Groundwater organic matter: carbon source or sink?	Chemistry, Geochemistry	1	2
Andy Baker (S)	C	University of New South Wales	School of Biological, Earth and Environmental Sciences						
Liza McDonough (G)	C	University of New South Wales	School of Biological, Earth and Environmental Sciences						
David Podgorski (S)	C	University of New Orleans	Department of Chemistry						
Robert Spencer (S)	C	Florida State University (FSU)	Earth, Ocean & Atmospheric Science						

# Appendix VI – User Proposals

Participants (Name, Role, Org., Dept.)		Funding Sources (Funding Agency, Division, Award #)		Proposal #	Proposal Title	Discipline	Exp. #	Days Used		
Robert Spencer (S)	PI	Florida State University (FSU)	Earth, Ocean & Atmospheric Science	National Natural Science Foundation of China	41230744	<b>P16161</b>	Controls of dissolved organic matter composition and its role in greenhouse gas emission	Chemistry, Geochemistry	1	4.25
Megan Behnke (G)	C	FSU	Earth, Ocean and Atmospheric Science							
David Podgorski (S)	C	University of New Orleans	Department of Chemistry							
Yongqiang Zhou (G)	C	Florida State University (FSU)	Earth, Ocean & Atmospheric Science							
Phoebe Zito (P)	C	Florida State University (FSU)	Earth, Ocean and Atmospheric Science							
Benjamin Abbott (S)	PI *	Michigan State University	Earth and Environmental Sciences	NSF - National Science Foundation	DEB-1026843	<b>P16158</b>	Could priming and nutrient effects from degrading permafrost alter dissolved organic matter dynamics in Arctic waterways?	Chemistry, Geochemistry	3	3.08
David Podgorski (S)	C	University of New Orleans	Department of Chemistry							
Robert Spencer (S)	C	Florida State University (FSU)	Earth, Ocean & Atmospheric Science							
Sadie Textor (U)	C	Florida State University (FSU)	Earth, Ocean, and Atmospheric Science							
Phoebe Zito (P)	C	Florida State University (FSU)	Earth, Ocean and Atmospheric Science							
David Goodlett (S)	PI *	University of Maryland, Baltimore	School of Pharmacology	No other support (i.e. this experiment is entirely supported by NHMFL users services via its core grant)		<b>P16153</b>	Top-Down Analysis of Lipopolysaccharide (LPS)	Biology, Biochemistry, Biophysics	1	4.5
Robert Ernst (S)	C	University of Maryland, Baltimore	Microbial Pathogenesis							
Benjamin Oyler (G)	C	University of Maryland, Baltimore	Toxicology							
Alison Scott (S)	C	University of Maryland, Baltimore	Dept. Microbial Pathogenesis							
Donald Smith (S)	C	National High Magnetic Field Laboratory (NHMFL)	ICR							

# Appendix VI – User Proposals

		Participants (Name, Role, Org., Dept.)		Funding Sources (Funding Agency, Division, Award #)			Proposal #	Proposal Title	Discipline	Exp. #	Days Used
Chad Weisbrod (S)	C	National High Magnetic Field Laboratory (NHMFL)	ICR								
Yunping Xu (S)	PI	Shanghai Ocean University	College of Marine Sciences	National Science Foundation of China			<b>P16150</b>	Molecular signatures of dissolved organic matter from New Britain Trench deep water	Chemistry, Geochemistry	1	1
David Podgorski (S)	C	University of New Orleans	Department of Chemistry								
Robert Spencer (S)	C	Florida State University (FSU)	Earth, Ocean & Atmospheric Science								
Yinghui Wang (G)	C	Florida State University (FSU)	Earth, Ocean & Atmospheric Science								
Phoebe Zito (P)	C	Florida State University (FSU)	Earth, Ocean and Atmospheric Science								
Eleanor Campbell (S)	PI	* University of Edinburgh	Chemistry	No other support (i.e. this experiment is entirely supported by NHMFL users services via its core grant)			<b>P16141</b>	Production of Clusters by Laser Ablation of Polymers	Chemistry, Geochemistry	1	3.5
Christopher Ewels (S)	C	University of Nantes	Institut des Materiaux Jean Rouxel								
Minas Stefanou (G)	C	University of Edinburgh	School of Chemistry								
Igor Alabugin (S)	PI	Florida State University (FSU)	Department of Chemistry & Biochemistry	NSF - National Science Foundation	CHE – Division of Chemistry	CHE-1465142	<b>P16125</b>	Design of Chiral Reagents for Click Chemistry	Chemistry, Geochemistry	1	1
Trevor Harris (G)	C	Florida State University (FSU)	Department of Chemistry and Biochemistry								
Logan Krajewski (G)	C	National High Magnetic Field Laboratory (NHMFL)	Chemistry and Biochemistry								
Gheorghe Bota (S)	PI	Ohio University	Chemical and Biomolecular Engineering	No other support (i.e. this experiment is entirely supported by NHMFL users services via its core grant)			<b>P16123</b>	Characterization of Residual Acids and Ketones Generated From Iron Corrosion of HVGO Acids	Chemistry, Geochemistry	1	4.5
Peng Jin (P)	C	Ohio University	Chemical and Biomolecular Engineering								

# Appendix VI – User Proposals

Participants (Name, Role, Org., Dept.)		Funding Sources (Funding Agency, Division, Award #)			Proposal #	Proposal Title	Discipline	Exp. #	Days Used
Logan Krajewski (G)	C	National High Magnetic Field Laboratory (NHMFL)	Chemistry and Biochemistry						
Winston Robbins (T)	C	Win Consulting Services	Petroleum Separations						
Steven Rowland (S)	C	National High Magnetic Field Laboratory (NHMFL)	Chemistry						
Andrew Yen (S)	PI	Nalco Energy Services	Ultra Deep Research Group	No other support (i.e. this experiment is entirely supported by NHMFL users services via its core grant)	P16116	Characterization of a Downhole Tar Sample from the Gulf of Mexico	Chemistry, Geochemistry	1	0.75
Amy McKenna (S)	C	National High Magnetic Field Laboratory (NHMFL)	ICR						
Ryan Rodgers (S)	C	National High Magnetic Field Laboratory (NHMFL)	ICR						
Chris Hendrickson (S)	PI	National High Magnetic Field Laboratory (NHMFL)	Ion Cyclotron Resonance Program	No other support (i.e. this experiment is entirely supported by NHMFL users services via its core grant)	P16115	Annual Maintenance to the FT-ICR MS systems	Magnets, Materials, Testing, Instrumentation	2	150
Greg Blakney (S)	C	National High Magnetic Field Laboratory (NHMFL)	ICR						
Paul Dunk (S)	C	National High Magnetic Field Laboratory (NHMFL)	Chemistry and Biochemistry						
John Quinn (T)	C	National High Magnetic Field Laboratory (NHMFL)	Ion Cyclotron Resonance Program						
Donald Smith (S)	C	National High Magnetic Field Laboratory (NHMFL)	ICR						

# Appendix VI – User Proposals

Participants (Name, Role, Org., Dept.)		Funding Sources (Funding Agency, Division, Award #)			Proposal #	Proposal Title	Discipline	Exp. #	Days Used	
Chris Hendrickson (S)	PI	National High Magnetic Field Laboratory (NHMFL)	Ion Cyclotron Resonance Program	No other support (i.e. this experiment is entirely supported by NHMFL users services via its core grant)	P16114	Upgrade to the 14.5 T FT-ICR MS System	Magnets, Materials, Testing, Instrumentation	2	286.5	
Greg Blakney (S)	C	National High Magnetic Field Laboratory (NHMFL)	ICR							
John Quinn (T)	C	National High Magnetic Field Laboratory (NHMFL)	Ion Cyclotron Resonance Program							
Donald Smith (S)	C	National High Magnetic Field Laboratory (NHMFL)	ICR							
Chad Weisbrod (S)	C	National High Magnetic Field Laboratory (NHMFL)	ICR							
Juliana D'Andrilli (S)	PI	Montana State University	Dept. of Land Resources and Environmental Sciences	Montana Agricultural Experiment Station	P16112	Permanganate oxidizable carbon distribution and organic matter spectroscopic features in three Montana soils	Chemistry, Geochemistry	2	2.5	
Logan Krajewski (G)	C	National High Magnetic Field Laboratory (NHMFL)	Chemistry and Biochemistry							
Carlos Romero (G)	C	Montana State University	Land Resources and Environmental Sciences							
Marianny Combariza (S)	PI *	Industrial University of Santander	Chemistry	Universidad Industrial de Santander	P16111	Correlations between molecular composition and the adsorption/aggregation behavior of Arabian asphaltenes	Chemistry, Geochemistry	1	3.33	
Cristian Blanco-Tirado (S)	C	Industrial University of Santander	Chemistry							
Martha Chacon (P)	C	National High Magnetic Field Laboratory (NHMFL)	Ion Cyclotron Resonance							
Jim Bruce (S)	PI	University of Washington	Genome Sciences	NIH - National Institutes of Health	NCI – National Cancer Institute	P16077	Interrogation of chemically cross-linked proteins at high magnetic field (14.5T,	Biology, Biochemistry, Biophysics	1	3
Juan Chavez (S)	C	University of Washington	Genome Sciences							

# Appendix VI – User Proposals

Participants (Name, Role, Org., Dept.)				Funding Sources (Funding Agency, Division, Award #)			Proposal #	Proposal Title	Discipline	Exp. #	Days Used
Chad Weisbrod (S)	C	National High Magnetic Field Laboratory (NHMFL)	ICR				21T)				
Chad Weisbrod (S)	PI	National High Magnetic Field Laboratory (NHMFL)	ICR	No other support (i.e. this experiment is entirely supported by NHMFL users services via its core grant)			<b>P16076</b>	21T Instrument hardware and software development	Magnets, Materials, Testing, Instrumentation	4	60.42
Greg Blakney (S)	C	National High Magnetic Field Laboratory (NHMFL)	ICR								
John Quinn (T)	C	National High Magnetic Field Laboratory (NHMFL)	Ion Cyclotron Resonance Program								
Donald Smith (S)	C	National High Magnetic Field Laboratory (NHMFL)	ICR								
Jamila Horabin (S)	PI	Florida State University (FSU)	Biomedical Sciences	No other support (i.e. this experiment is entirely supported by NHMFL users services via its core grant)			<b>P16065</b>	Contribution of RNA Silencing Machinery Towards Heterochromatin Formation in Drosophila	Biology, Biochemistry, Biophysics	1	5.58
Lissa Anderson (S)	C	National High Magnetic Field Laboratory (NHMFL)	ICR								
Tingting Jiang (G)	C	National High Magnetic Field Laboratory (NHMFL)	Department of Chemistry								
Ursula Olcese (T)	C	Florida State University (FSU)	Biomedical Sciences								
Brian Miller (S)	PI	Florida State University (FSU)	Chemistry	NIH - National Institutes of Health	NIGMS – National Institute of General Medical Sciences	GM115388	<b>P16058</b>	Determining the Mechanistic Origin of Glucokinase Cooperativity and Activation	Biology, Biochemistry, Biophysics	1	4
Peilu Liu (G)	C	Florida State University (FSU)	Chemistry								
Alan Marshall (S)	C	National High Magnetic Field Laboratory	ICR								



# Appendix VI – User Proposals

Participants (Name, Role, Org., Dept.)		Funding Sources (Funding Agency, Division, Award #)			Proposal #	Proposal Title	Discipline	Exp. #	Days Used
Shawn Sternisha (G)	C	(NHMFL) Florida State University (FSU)	Department of Chemistry & Biochemistry						
Yunping Xu (S)	PI	Shanghai Ocean University	College of Marine Sciences	National Basic Research Program of China	<b>P16057</b>	Optical properties and bioavailability of dissolved organic matter in an alpine stream from thawing and collapsing permafrost to Qinghai Lake	Chemistry, Geochemistry	1	0.5
David Podgorski (S)	C	University of New Orleans	Department of Chemistry						
Robert Spencer (S)	C	Florida State University (FSU)	Earth, Ocean & Atmospheric Science						
Yunping Xu (S)	C	Shanghai Ocean University	College of Marine Sciences						
Phoebe Zito (P)	C	Florida State University (FSU)	Earth, Ocean and Atmospheric Science						
Ryan Rodgers (S)	PI	National High Magnetic Field Laboratory (NHMFL)	ICR	Baker Hughes Educational Research Agreement	<b>P16048</b>	Characterization of Petroleum Interfacial Material by Fourier Transform Ion Cyclotron Resonance Mass Spectrometry	Chemistry, Geochemistry	3	19.67
Martha Chacon (P)	C	National High Magnetic Field Laboratory (NHMFL)	Ion Cyclotron Resonance						
Sydney Niles (G)	C	National High Magnetic Field Laboratory (NHMFL)	Chemistry						
Steven Rowland (S)	C	National High Magnetic Field Laboratory (NHMFL)	Chemistry						
Richard LaBrie (S)	PI	University of Montreal	Sciences biologiques	Natural Sciences and Engineering Research Council of Canada (NSERC)	<b>P16044</b>	Experimental assessment of the microbial carbon pump in the Labrador Sea	Chemistry, Geochemistry	1	0.33
Yuri Corilo (S)	C	National High Magnetic Field Laboratory (NHMFL)	ICR						
Francois Guillemette (S)	C	University of Quebec at Trois-Rivières	Dept. of Environmental Sciences						

# Appendix VI – User Proposals

Participants (Name, Role, Org., Dept.)		Funding Sources (Funding Agency, Division, Award #)		Proposal #	Proposal Title	Discipline	Exp. #	Days Used	
David Podgorski (S)	C	University of New Orleans	Department of Chemistry						
Robert Spencer (S)	C	Florida State University (FSU)	Earth, Ocean & Atmospheric Science						
Pierre Giusti (S)	PI	Total	Research & Technology	No other support (i.e. this experiment is entirely supported by NHMFL users services via its core grant)	<b>P16042</b>	Analysis of Petroleum Products by Gel Permeation Chromatography (GPC) Online with Inductively Coupled Plasma Mass Spectrometry (ICP MS) and Offline with Fourier Transform Ion Cyclotron Resonance Mass Spectrometry (FT-ICR MS)	Chemistry, Geochemistry	1	7.83
Patrick Bouriat (S)	C	Lacq Research and Studies Center	Petroleum						
Brice Bouyssiere (S)	C	University of Pau and Pays de l'Adour	IPREM						
Christophe Dicharry (S)	C	University of Pau and Pays de l'Adour	Petroleum						
Pierre Giusti (S)	C	Total	Research & Technology						
Sara Gutiérrez Sama (G)	C	University of Pau and Pays de l'Adour	LCABIE						
Leticia Ligiero (S)	C	University of Pau and Pays de l'Adour	Complex Fluids						
Caroline Mangote (S)	C	Total	Research & Technology						
Alan Marshall (S)	C	National High Magnetic Field Laboratory (NHMFL)	ICR						
Nicolas Passade-Boupat (S)	C	Total	PERL PCA						
Jonathan Putman (G)	C	National High Magnetic Field Laboratory (NHMFL)	Ion Cyclotron Resonance User Facility						
Ryan Rodgers (S)	C	National High Magnetic Field Laboratory (NHMFL)	ICR						

# Appendix VI – User Proposals

Participants (Name, Role, Org., Dept.)		Funding Sources (Funding Agency, Division, Award #)			Proposal #	Proposal Title	Discipline	Exp. #	Days Used
Steven Rowland (S)	C	National High Magnetic Field Laboratory (NHMFL)	Chemistry						
Bob Swarthout (S)	PI	Appalachian State University	Department of Chemistry	NSF - National Science Foundation	EE 15-47132	P16021 Oil weathering following the other major oil spill of 2010: the Kalamazoo River dilbit spill	Chemistry, Geochemistry	1	1.42
Christoph Aeppli (P)	C	Woods Hole Oceanographic Institution	Dept Marine Chemistry & Geochemistry	NSF - National Science Foundation	OCE 16-34999				
Huan Chen (S)	C	National High Magnetic Field Laboratory (NHMFL)	Ion Cyclotron Resonance						
Amy McKenna (S)	C	National High Magnetic Field Laboratory (NHMFL)	ICR						
Robert Nelson (S)	C	Woods Hole Oceanographic Institution	Dept Marine Chemistry and Geochemistry						
Chris Reddy (S)	C	Woods Hole Oceanographic Institution	Geochemistry						
Dave Valentine (S)	C	University of California, Santa Barbara	Department of Geological Sciences						
Huan Chen (S)	PI	National High Magnetic Field Laboratory (NHMFL)	Ion Cyclotron Resonance	NSF - National Science Foundation	OCE - Ocean Sciences OCE1333418	P16019 Unraveling of the Chemical Evolution of Weathered Macondo Oil: 2010-2018	Chemistry, Geochemistry	2	19.75
Christoph Aeppli (P)	C	Woods Hole Oceanographic Institution	Dept Marine Chemistry & Geochemistry	Gulf of Mexico Research Initiative					
Cameron Davis (U)	C	National High Magnetic Field Laboratory (NHMFL)	ICR/CIRL	NSF - National Science Foundation	OCE - Ocean Sciences OCE1635562				
Ashley Deverteuil (U)	C	National High Magnetic Field Laboratory (NHMFL)	ICR	NSF - National Science Foundation	OCE - Ocean Sciences OCE1634478				
Amy McKenna (S)	C	National High Magnetic Field Laboratory (NHMFL)	ICR						

# Appendix VI – User Proposals

Participants (Name, Role, Org., Dept.)		Funding Sources (Funding Agency, Division, Award #)			Proposal #	Proposal Title	Discipline	Exp. #	Days Used	
Robert Nelson (S)	C	Woods Hole Oceanographic Institution	Dept Marine Chemistry and Geochemistry							
Sydney Niles (G)	C	National High Magnetic Field Laboratory (NHMFL)	Chemistry							
Chris Reddy (S)	C	Woods Hole Oceanographic Institution	Geochemistry							
Ryan Rodgers (S)	C	National High Magnetic Field Laboratory (NHMFL)	ICR							
Alexys Sutton (O)	C	National High Magnetic Field Laboratory (NHMFL)	NHMFL/ICR							
Dave Valentine (S)	C	University of California, Santa Barbara	Department of Geological Sciences							
Robert Spencer (S)	PI	Florida State University (FSU)	Earth, Ocean & Atmospheric Science	The Fish and Wildlife Foundation of Florida	<b>P16014</b>	Restoring the Mysterious Waters of Wakulla Springs: Drivers of Organic Matter Composition That Impact Water Quality	Chemistry, Geochemistry	1	1	
H. Edward Chelette (S)	C	Northwest Florida Water Management District	Resource Management							
Francois Guillemette (S)	C	University of Quebec at Trois-Rivières	Dept. of Environmental Sciences							
Casey Luzius (G)	C	Florida State University (FSU)	EOAS							
David Podgorski (S)	C	University of New Orleans	Department of Chemistry							
Phoebe Zito (P)	C	Florida State University (FSU)	Earth, Ocean and Atmospheric Science							
William McDowell (S)	PI	University of New Hampshire	Natural Resources and the Environment	NSF - National Science Foundation	DEB 15-56603	<b>P16011</b>	DOM composition and nutrient uptake in arctic streams	Chemistry, Geochemistry	1	0.58
Ashley Coble (P)	C	University of New Hampshire	Natural Resources and the Environment							

# Appendix VI – User Proposals

Participants (Name, Role, Org., Dept.)		Funding Sources (Funding Agency, Division, Award #)		Proposal #	Proposal Title	Discipline	Exp. #	Days Used	
William McDowell (S)	C	University of New Hampshire	Natural Resources and the Environment						
David Podgorski (S)	C	University of New Orleans	Department of Chemistry						
Anatoly Prokushkin (S)	C	VN Sukachev Institute of Forest SB RAS	Laboratory of biogeochemical cycles in forest ecosystems						
Robert Spencer (S)	C	Florida State University (FSU)	Earth, Ocean & Atmospheric Science						
Adam Wymore (P)	C	University of New Hampshire	Natural Resources and the Environment						
Phoebe Zito (P)	C	Florida State University (FSU)	Earth, Ocean and Atmospheric Science						
Pamela Vaughan (S)	PI	University of West Florida	Department of Chemistry	No other support (i.e. this experiment is entirely supported by NHMFL users services via its core grant)	<b>P16006</b>	Method Validation Using ICRMS analysis of a New Solid Phase Extraction Protocol for Petroleum Residues	Chemistry, Geochemistry	1	3
Huan Chen (S)	C	National High Magnetic Field Laboratory (NHMFL)	Ion Cyclotron Resonance						
Cameron Davis (U)	C	National High Magnetic Field Laboratory (NHMFL)	ICR/CIRL						
Brett Farran (U)	C	University of West Florida	Chemistry						
Wade Jeffrey (S)	C	University of West Florida	Center for Environmental Diagnostics and Bioremediation						
Amy McKenna (S)	C	National High Magnetic Field Laboratory (NHMFL)	ICR						
Ryan Rodgers (S)	PI	National High Magnetic Field Laboratory (NHMFL)	ICR	No other support (i.e. this experiment is entirely supported by NHMFL users services via its core grant)	<b>P15992</b>	Characterization of Petroleum Pigging Returns	Chemistry, Geochemistry	2	5.67

# Appendix VI – User Proposals

Participants (Name, Role, Org., Dept.)		Funding Sources (Funding Agency, Division, Award #)			Proposal #	Proposal Title	Discipline	Exp. #	Days Used
Logan Krajewski (G)	C	National High Magnetic Field Laboratory (NHMFL)	Chemistry and Biochemistry						
Steven Rowland (S)	C	National High Magnetic Field Laboratory (NHMFL)	Chemistry						
Andrew Yen (S)	C	Nalco Energy Services	Ultra Deep Research Group						
Daniel Repeta (S)	PI	Woods Hole Oceanographic Institution	Marine Chemistry	NSF - National Science Foundation	OCE - Ocean Sciences	OCE1356747	Mass spectral characterization of copper and metal ligands from the eastern tropical Pacific Ocean.	1	9.33
Katherine Barbeau (S)	C	University of California, San Diego	Scripps Institution of Oceanography	NSF - National Science Foundation	OCE - Ocean Sciences	OCE1233261			
Rene Boiteau (P)	C	Woods Hole Oceanographic Institution	Oceanography	NSF - National Science Foundation	OCE - Ocean Sciences	OCE1233733			
Kenneth Bruland (S)	C	University of California, Santa Cruz	Ocean Sciences	NSF - National Science Foundation	OCE - Ocean Sciences	OCE1233502			
Randelle Bundy (S)	C	Woods Hole Oceanographic Institution	Marine Chemistry & Geochemistry	NSF - National Science Foundation	OCE - Ocean Sciences	OCE1237034			
Huan Chen (S)	C	National High Magnetic Field Laboratory (NHMFL)	Ion Cyclotron Resonance	NSF - National Science Foundation		C-MORE DBI-0424599			
Yuri Corilo (S)	C	National High Magnetic Field Laboratory (NHMFL)	ICR	Gordon and Betty Moore Foundation					
Nicholas Hawco (G)	C	Woods Hole Oceanographic Institution	Marine Chemistry & Geochemistry	Simons Foundation					
Amy McKenna (S)	C	National High Magnetic Field Laboratory (NHMFL)	ICR						
Angel Ruacho (S)	C	University of California, San Diego	Scripps Institution of Oceanography						
Mak Saito (S)	C	Woods Hole Oceanographic Institution	Marine Chemistry & Geochemistry						

# Appendix VI – User Proposals

		Participants (Name, Role, Org., Dept.)		Funding Sources (Funding Agency, Division, Award #)			Proposal #	Proposal Title	Discipline	Exp. #	Days Used
Claire Till (S)	C	Humboldt State	Dept. of Chemistry								
Michelle Arbeitman (S)	PI	Florida State University (FSU)	Biomedical Sciences	NIH - National Institutes of Health	NIGMS – National Institute of General Medical Sciences	GM073039	<b>P14951</b>	Sex Differences in Histone Modifications	Biology, Biochemistry, Biophysics	1	15.17
Lissa Anderson (S)	C	National High Magnetic Field Laboratory (NHMFL)	ICR	NIH - National Institutes of Health		NS090184					
Tingting Jiang (G)	C	National High Magnetic Field Laboratory (NHMFL)	Department of Chemistry								
Shawn Moseley (T)	C	Florida State University (FSU)	Biomedical Science								
Hong Li (S)	PI	Florida State University (FSU)	Chemistry	NIH - National Institutes of Health	NIGMS – National Institute of General Medical Sciences	GM66958	<b>P14944</b>	Mapping the interaction interface of a protein-protein complex	Biology, Biochemistry, Biophysics	1	0.83
Borries Demeler (S)	C	University of Texas Health Science Center at San Antonio	Biochemistry and Structural Biology								
Huan He (S)	C	IMB, FSU	Institute of Molecular Biophysics								
Peilu Liu (G)	C	Florida State University (FSU)	Chemistry								
Alan Marshall (S)	C	National High Magnetic Field Laboratory (NHMFL)	ICR								
Shaoxiong Tian (G)	C	Florida State University (FSU)	Chemistry								
Ge Yu (S)	C	Florida State University	Chemistry								
Yu Zhao (G)	C	Florida State University	Molecular Biophysics								
Joseph Suflita (S)	PI	University of Oklahoma	Department of Microbiology and Plant Biology	Gulf of Mexico Research Initiative			<b>P14927</b>	Biodegradation of Photosolubilized Weathered Oil Components	Chemistry, Geochemistry	1	3
Brian Harriman (G)	C	University of Oklahoma	Department of Microbiology and Plant Biology								

# Appendix VI – User Proposals

Participants (Name, Role, Org., Dept.)			Funding Sources (Funding Agency, Division, Award #)		Proposal #	Proposal Title	Discipline	Exp. #	Days Used	
David Podgorski (S)	C	University of New Orleans	Department of Chemistry							
Matthew Tarr (S)	C	University of New Orleans	Department of Chemistry							
Phoebe Zito (P)	C	Florida State University (FSU)	Earth, Ocean and Atmospheric Science							
Thomas Manning (S)	PI	Valdosta State University	Chemistry	NIH - National Institutes of Health	HHSN272201100009I	<b>P14897</b>	Copper Complexes by FT-ICR	Chemistry, Geochemistry	1	0.83
Logan Krajewski (G)	C	National High Magnetic Field Laboratory (NHMFL)	Chemistry and Biochemistry	NSF - National Science Foundation	DUE 12-40059					
Dennis Phillips (S)	C	University of Georgia	Chemistry							
Sydney Plummer (U)	C	Valdosta State University	Chemistry							
Kyle Wilkerson (U)	C	Valdosta State University	Chemistry							
Greg Wylie (S)	C	University of Georgia	Chemistry							
Tanner Schaub (S)	PI	New Mexico State University	Chemical Analysis and Instrumentation Laboratory	NSF - National Science Foundation	IIA-1301346	<b>P14896</b>	Direct comparison of HTL oil composition to petroleum crude oil composition	Chemistry, Geochemistry	1	0.5
Justin Billing (S)	C	Pacific Northwest National Laboratory	Chemical & Biological Process Development Group	NSF - National Science Foundation	1626468					
Richard Hallen (S)	C	Pacific Northwest National Laboratory	Chemical and Process Development							
Jackie Jarvis (S)	C	New Mexico State University	Chemical Analysis and Instrumentation Laboratory							
Andrew Schmidt (S)	C	Pacific Northwest National Laboratory	Chemical & Biological Processes Group							
Ni-Bin Chang (S)	PI	University of Central Florida	Department of Civil Engineering	No other support (i.e. this experiment is entirely supported by NHMFL users services via its core grant)		<b>P14856</b>	Study of Biological removal effects of dissolved organic nitrogen (DON) through biosorption activated	Engineering	1	1.17



# Appendix VI – User Proposals

Participants (Name, Role, Org., Dept.)		Funding Sources (Funding Agency, Division, Award #)			Proposal #	Proposal Title	Discipline	Exp. #	Days Used		
Ni-Bin Chang (S)	C	University of Central Florida	Department of Civil Engineering				media (BAM)				
Huan Chen (S)	C	National High Magnetic Field Laboratory (NHMFL)	Ion Cyclotron Resonance								
Nicholas Hartshorn (G)	C	University of Central Florida	Civil, Environmental, and Construction Engineering								
Amy McKenna (S)	C	National High Magnetic Field Laboratory (NHMFL)	ICR								
Dan Wen (G)	C	University of Central Florida	Civil Environmental & Construction Engineering								
Neil Kelleher (S)	PI	Northwestern University	Department of Biochemistry, Molecular Biology, and Cell Biology	NIH - National Institutes of Health	NIGMS – National Institute of General Medical Sciences	GM108569	<b>P14853</b>	Characterization of p53 proteoforms by top-down mass spectrometry at 21T	Biology, Biochemistry, Biophysics	1	1
Lissa Anderson (S)	C	National High Magnetic Field Laboratory (NHMFL)	ICR								
Caroline DeHart (P)	C	Northwestern University	Proteomics Center of Excellence								
Jeremy Gunawardena (S)	C	Harvard University	Systems Biology								
John Headley (S)	PI	Environment and Climate Change Canada	National Hydrology Research Centre	Program of Energy Research and Development (PERD)			<b>P14852</b>	High resolution FTICR-MS analyses of naphthenic acid fraction compounds(NAFC) in wetlands samples	Chemistry, Geochemistry	1	0.5
Chukwuemeka Ajaero (G)	C	University of Regina	Environmental Systems Engineering								
Jon Bailey (S)	C	Environment and Climate Change Canada	Water Science & Technology								
Christine Brown (S)	C	Shell Canada	Shell Canada								
Huan Chen (S)	C	National High Magnetic Field Laboratory (NHMFL)	Ion Cyclotron Resonance								

# Appendix VI – User Proposals

Participants (Name, Role, Org., Dept.)		Funding Sources (Funding Agency, Division, Award #)			Proposal #	Proposal Title	Discipline	Exp. #	Days Used		
Vanessa Friesen (S)	C	Contango Strategies	Water Science & Technology								
Monique Haakensen (S)	C	Contango Strategies	N/A								
Sarah Hughes (S)	C	Shell Canada	Risk Science Team								
Rachel Martz (S)	C	Contango Strategies	Water Science & Technology								
Dena McMartin (S)	C	University of Regina	Faculty of Engineering and Applied Science								
Kerry Peru (P)	C	Environment and Climate Change Canada	Protection Research Division								
Robert Spencer (S)	PI	Florida State University (FSU)	Earth, Ocean & Atmospheric Science	NASA - National Aeronautics and Space Administration	CORE	<b>P14844</b>	Drivers of chromophoric dissolved organic matter in Alaska lakes	Chemistry, Geochemistry	1	1.5	
Megan Behnke (G)	C	FSU	Earth, Ocean and Atmospheric Science								
Lizzie Grater (U)	C	Florida State University (FSU)	Earth, Ocean and Atmospheric Science								
Sarah Johnston (G)	C	National High Magnetic Field Laboratory (NHMFL)	Earth Ocean and Atmospheric Sciences								
David Podgorski (S)	C	University of New Orleans	Department of Chemistry								
Phoebe Zito (P)	C	Florida State University (FSU)	Earth, Ocean and Atmospheric Science								
Ryan Rodgers (S)	PI	National High Magnetic Field Laboratory (NHMFL)	ICR	NSF - National Science Foundation	DMR – Division of Materials Research	DMR11-57490	<b>P14839</b>	Comprehensive Simulation/Projection of Heavy Crude Oil Distillation and Detailed Molecular Composition Prediction by Direct-Infusion Fourier Transform Ion Cyclotron Mass Spectrometry	Chemistry, Geochemistry	1	1.33
Martha Chacon (P)	C	National High Magnetic Field Laboratory (NHMFL)	Ion Cyclotron Resonance								
Yuri Corilo (S)	C	National High Magnetic Field Laboratory (NHMFL)	ICR								

# Appendix VI – User Proposals

Participants (Name, Role, Org., Dept.)		Funding Sources (Funding Agency, Division, Award #)			Proposal #	Proposal Title	Discipline	Exp. #	Days Used		
Priscila Lalli (S)	C	National High Magnetic Field Laboratory (NHMFL)	ICR								
Ryan Rodgers (S)	C	National High Magnetic Field Laboratory (NHMFL)	ICR								
Toru Maekawa (S)	PI	Toyo University, Kawagoe	Bio-Nano Electronics Research Centre	No other support (i.e. this experiment is entirely supported by NHMFL users services via its core grant)	<b>P14830</b>	Fullerene Modification in Reactive Plasmas	Chemistry, Geochemistry	1	41		
Paul Dunk (S)	C	National High Magnetic Field Laboratory (NHMFL)	Chemistry and Biochemistry								
Richard Racz (P)	C	Institute for Nuclear Research, Hungarian Academy of Sciences	Accelerator Center								
Takashi Uchida (S)	C	Toyo University, Kawagoe	Bio-Nano Electronics Research Centre								
Neil Kelleher (S)	PI	Northwestern University	Department of Biochemistry, Molecular Biology, and Cell Biology	NIH - National Institutes of Health	NIGMS – National Institute of General Medical Sciences	GM411085	<b>P14822</b>	Analysis of human cell lysate by qualitative top-down proteomics at 21T	Biology, Biochemistry, Biophysics	1	6.33
Lissa Anderson (S)	C	National High Magnetic Field Laboratory (NHMFL)	ICR	National Resource for Translational and Developmental Proteomics							
Caroline DeHart (P)	C	Northwestern University	Proteomics Center of Excellence								
Ryan Fellers (S)	C	Northwestern University	Departments of Chemistry and Molecular Biosciences and the Proteomics Center of Excellence								
Joseph Greer (S)	C	Northwestern University	Proteomics								

# Appendix VI – User Proposals

Participants (Name, Role, Org., Dept.)		Funding Sources (Funding Agency, Division, Award #)			Proposal #	Proposal Title	Discipline	Exp. #	Days Used
Richard LeDuc (S)	C	Northwestern University	Proteomics						
Donald Smith (S)	C	National High Magnetic Field Laboratory (NHMFL)	ICR						
Paul Thomas (S)	C	Northwestern University	Departments of Chemistry and Molecular Biosciences and the Proteomics Center of Excellence						
David Podgorski (S)	PI	University of New Orleans	Department of Chemistry	No other support (i.e. this experiment is entirely supported by NHMFL users services via its core grant)	<b>P14817</b>	Method Development for Dissolved Organic Matter	Biology, Biochemistry, Biophysics	1	1.08
Logan Krajewski (G)	C	National High Magnetic Field Laboratory (NHMFL)	Chemistry and Biochemistry						
Priscila Lalli (S)	C	National High Magnetic Field Laboratory (NHMFL)	ICR						
Vladislav Lobodin (S)	C	National High Magnetic Field Laboratory (NHMFL)	Future Fuels Institute						
Jonathan Putman (G)	C	National High Magnetic Field Laboratory (NHMFL)	Ion Cyclotron Resonance User Facility						
Steven Rowland (S)	C	National High Magnetic Field Laboratory (NHMFL)	Chemistry						
Donald Smith (S)	C	National High Magnetic Field Laboratory (NHMFL)	ICR						
Rebecca Ware (G)	C	National High Magnetic Field Laboratory (NHMFL)	Chemistry						

# Appendix VI – User Proposals

Participants (Name, Role, Org., Dept.)		Funding Sources (Funding Agency, Division, Award #)		Proposal #	Proposal Title	Discipline	Exp. #	Days Used	
Phoebe Zito (P)	C	Florida State University (FSU)	Earth, Ocean and Atmospheric Science						
George Aiken (S)	PI *	U.S. Geological Survey	Chemistry	U.S. Geological Survey	<b>P14816</b>	Molecular-level insights into the optical properties of dissolved organic matter	Biology, Biochemistry, Biophysics	1	2
Francois Guillemette (S)	C	University of Quebec at Trois-Rivières	Dept. of Environmental Sciences						
Anne Kellerman (P)	C	Florida State University (FSU)	Earth, Ocean and Atmospheric Science						
David Podgorski (S)	C	University of New Orleans	Department of Chemistry						
Robert Spencer (S)	C	Florida State University (FSU)	Earth, Ocean & Atmospheric Science						
Phoebe Zito (P)	C	Florida State University (FSU)	Earth, Ocean and Atmospheric Science						
John Maier (S)	PI	University of Basel	Chemistry	No other support (i.e. this experiment is entirely supported by NHMFL users services via its core grant)	<b>P14805</b>	Hydrogenated Fullerenes: Dissociation into Polycyclic Aromatic Hydrocarbons and Implications to Astrochemistry	Chemistry, Geochemistry	1	40.5
Ewen Campbell (P)	C	University of Basel	Chemistry						
Paul Dunk (S)	C	National High Magnetic Field Laboratory (NHMFL)	Chemistry and Biochemistry						
Marc Mulet Gas (P)	C	National High Magnetic Field Laboratory (NHMFL)	Ion Cyclotron Resonance						
Martha Chacon (P)	PI	National High Magnetic Field Laboratory (NHMFL)	Ion Cyclotron Resonance	Bicentenary Scholarship from the Colombian National Program for Ph.D. Studies	<b>P14799</b>	Characterization of Asphaltene subfractions by (+) APPI FT-ICR mass spectrometry	Chemistry, Geochemistry	3	42
Amy McKenna (S)	C	National High Magnetic Field Laboratory (NHMFL)	ICR						
Ryan Rodgers (S)	C	National High Magnetic Field Laboratory (NHMFL)	ICR						

# Appendix VI – User Proposals

Participants (Name, Role, Org., Dept.)		Funding Sources (Funding Agency, Division, Award #)			Proposal #	Proposal Title	Discipline	Exp. #	Days Used	
Steven Rowland (S)	C	National High Magnetic Field Laboratory (NHMFL)	Chemistry							
Paul Mann (S)	PI	Northumbria University	Geography	Northumbria University	P14739	Dynamics of DOM composition and microbial function in streams: Investigating the influence of land-cover and permafrost loss across a sub-arctic landscape gradient	Chemistry, Geochemistry	1	2	
Francois Guillemette (S)	C	University of Quebec at Trois-Rivières	Dept. of Environmental Sciences							
David Podgorski (S)	C	University of New Orleans	Department of Chemistry							
Robert Spencer (S)	C	Florida State University (FSU)	Earth, Ocean & Atmospheric Science							
Phoebe Zito (P)	C	Florida State University (FSU)	Earth, Ocean and Atmospheric Science							
Patricia Medeiros (S)	PI	University of Georgia	Marine Sciences	NSF - National Science Foundation	OCE 12-34388	P14726	Untargeted Characterization of Dissolved Organic Matter Transformations by Bacterioplankton	Chemistry, Geochemistry	1	5
Jonathan Amster (S)	C	University of Georgia	Department of Chemistry	NSF - National Science Foundation	OCE 16-32090					
Lydia Babcock-Adams (G)	C	University of Georgia	Marine Sciences	NSF - National Science Foundation	PLR 16-43468					
Ford Ballantyne (S)	C	University of Georgia	Odum School of Ecology							
Renato Castelao (S)	C	University of Georgia	Marine Sciences							
Huan Chen (S)	C	National High Magnetic Field Laboratory (NHMFL)	Ion Cyclotron Resonance							
Joshua Driver (G)	C	University of Georgia	Chemistry							
Maria Letourneau (G)	C	University of Georgia	Marine Sciences							
Mary Ann Moran (S)	C	University of Georgia	Marine Sciences							
William Whitman (S)	C	University of Georgia	Microbiology							
Amy McKenna (S)	PI	National High Magnetic Field Laboratory (NHMFL)	ICR	No other support (i.e. this experiment is entirely supported by NHMFL users services via its core grant)		P14725	Stormwater Dissolved Organic Matter : Characterization of Leon County Stormwater Lakes by	Engineering	2	4.5

# Appendix VI – User Proposals

Participants (Name, Role, Org., Dept.)		Funding Sources (Funding Agency, Division, Award #)			Proposal #	Proposal Title	Discipline	Exp. #	Days Used		
Huan Chen (S)	C	National High Magnetic Field Laboratory (NHMFL)	Ion Cyclotron Resonance				Ultrahigh Resolution Fourier Transform Ion Cyclotron Mass Spectrometry				
Cameron Davis (U)	C	National High Magnetic Field Laboratory (NHMFL)	ICR/CIRL								
TuKiet Lam (S)	PI	Yale University	WM Keck Foundation Biotechnology Resource Laboratory ICR	NIH - National Institutes of Health	NIGMS – National Institute of General Medical Sciences	GM 100411	P14715	The Fold of the cortactin repeats and their interaction with Actin	Biology, Biochemistry, Biophysics	1	0.5
Lissa Anderson (S)	C	National High Magnetic Field Laboratory (NHMFL)									
Anthony Koleske (G)	C	Yale University	Yale University								
TuKiet Lam (S)	C	Yale University	WM Keck Foundation Biotechnology Resource Laboratory								
Xiaofeng Li (S)	C	Yale University	Yale University School of Medicine								
James Murphy (S)	C	Yale University	Yale University School of Medicine								
Alexander Scherer (G)	C	Yale University	Cell Biology								
Yeqing Tao (G)	C	National High Magnetic Field Laboratory (NHMFL)	ICR								
Juliana D'Andrilli (S)	PI	Montana State University	Dept. of Land Resources and Environmental Sciences	NSF - National Science Foundation		ANT 11-41936	P14713	Characterization of Glacial Dissolved Organic Matter	Chemistry, Geochemistry	1	0.5
Markus Dieser (G)	C	Montana State University	Environmental Sciences	NSF - National Science Foundation		DGE 06-54336					
Christine Foreman (S)	C	Montana State University	Center for Biofilm Engineering & Dept. of Land Resources and Environmental Sciences								

# Appendix VI – User Proposals

Participants (Name, Role, Org., Dept.)		Funding Sources (Funding Agency, Division, Award #)			Proposal #	Proposal Title	Discipline	Exp. #	Days Used
David Podgorski (S)	C	University of New Orleans	Department of Chemistry						
Heidi Smith (G)	C	Montana State University	Environmental Sciences						
Phoebe Zito (P)	C	Florida State University (FSU)	Earth, Ocean and Atmospheric Science						
Chris Hendrickson (S)	PI	National High Magnetic Field Laboratory (NHMFL)	Ion Cyclotron Resonance Program	No other support (i.e. this experiment is entirely supported by NHMFL users services via its core grant)	<b>P14709</b>	Top-Down Site Mapping N-Glycosylation by Ultrahigh Resolution FT-ICR MS/MS	Biology, Biochemistry, Biophysics	2	6
Tingting Jiang (G)	C	National High Magnetic Field Laboratory (NHMFL)	Department of Chemistry						
Alan Marshall (S)	C	National High Magnetic Field Laboratory (NHMFL)	ICR						
Kimberly Wickland (S)	PI	U.S. Geological Survey	National Research Program	U.S. Geological Survey	<b>P14703</b>	Understanding influences of land-use and seasonality on in-stream reactivity and transformations of DOM through ultrahigh resolution mass spectrometry	Chemistry, Geochemistry	1	0.25
George Aiken (S)	C	U.S. Geological Survey	Chemistry						
Anne Kellerman (P)	C	Florida State University (FSU)	Earth, Ocean and Atmospheric Science						
David Podgorski (S)	C	University of New Orleans	Department of Chemistry						
Robert Spencer (S)	C	Florida State University (FSU)	Earth, Ocean & Atmospheric Science						
Phoebe Zito (P)	C	Florida State University (FSU)	Earth, Ocean and Atmospheric Science						
Susan Pedigo (S)	PI	University of Mississippi	Chemistry and Biochemistry	Department of Education	<b>P14681</b>	Probing Cadherin Interactions by Hydrogen/Deuterium Exchange Mass Spectrometry	Biology, Biochemistry, Biophysics	1	1
Samantha Davila (G)	C	University of Mississippi	Chemistry and Biochemistry						
Peilu Liu (G)	C	Florida State University (FSU)	Chemistry						
Alan Marshall (S)	C	National High Magnetic Field Laboratory (NHMFL)	ICR						



# Appendix VI – User Proposals

Participants (Name, Role, Org., Dept.)				Funding Sources (Funding Agency, Division, Award #)		Proposal #	Proposal Title	Discipline	Exp. #	Days Used
Yeqing Tao (G)	C	National High Magnetic Field Laboratory (NHMFL)	ICR							
Pamela Vaughan (S)	PI	University of West Florida	Department of Chemistry	Gulf of Mexico Research Initiative		<b>P14679</b>	FT-ICR MS Analysis of Weathered Surrogate Oil and Water Accomodated Fractions	Chemistry, Geochemistry	1	0.25
Huan Chen (S)	C	National High Magnetic Field Laboratory (NHMFL)	Ion Cyclotron Resonance							
Melissa Hagy (T)	C	University of West Florida	Center for Environmental Diagnostics and Bioremediation							
Wade Jeffrey (S)	C	University of West Florida	Center for Environmental Diagnostics and Bioremediation							
Rebecca Kamerman (U)	C	University of West Florida	Chemistry							
Amy McKenna (S)	C	National High Magnetic Field Laboratory (NHMFL)	ICR							
Tashiema Wilson (U)	C	University of West Florida	Chemistry							
Karen Frey (S)	PI	Clark University	Graduate School of Geography	NSF - National Science Foundation	PLR 1107596	<b>P14674</b>	Seasonality of chromophoric dissolved organic matter and molecular composition in Arctic lakes along the North Slope of Alaska	Chemistry, Geochemistry	1	1
Francois Guillemette (S)	C	University of Quebec at Trois-Rivières	Dept. of Environmental Sciences							
David Podgorski (S)	C	University of New Orleans	Department of Chemistry							
Robert Spencer (S)	C	Florida State University (FSU)	Earth, Ocean & Atmospheric Science							
Phoebe Zito (P)	C	Florida State University (FSU)	Earth, Ocean and Atmospheric Science							
David Barnidge (S)	PI	Mayo Clinic, Rochester	Laboratory Medicine and Pathology	No other support (i.e. this experiment is entirely supported by NHMFL users services via its core grant)		<b>P14665</b>	Mass spectrometry analysis of monoclonal immunoglobulins in patients with plasma cell proliferative	Biology, Biochemistry, Biophysics	2	29

# Appendix VI – User Proposals

		Participants (Name, Role, Org., Dept.)		Funding Sources (Funding Agency, Division, Award #)			Proposal #	Proposal Title	Discipline	Exp. #	Days Used
Lissa Anderson (S)	C	National High Magnetic Field Laboratory (NHMFL)	ICR					disorders			
Lidong He (G)	C	National High Magnetic Field Laboratory (NHMFL)	Chemistry								
Alan Marshall (S)	C	National High Magnetic Field Laboratory (NHMFL)	ICR								
David Murray (S)	C	Mayo Clinic, Rochester	Laboratory Medicine and Pathology								
Dave Valentine (S)	PI	University of California, Santa Barbara	Department of Geological Sciences	The BP Gulf of Mexico Research Initiative			<b>P12585</b>	Distinguishing Oil Released from the 2015 Refugio Oil Spill from Natural Seepage in Santa Barbara Basin	Chemistry, Geochemistry	1	1
Martha Chacon (P)	C	National High Magnetic Field Laboratory (NHMFL)	Ion Cyclotron Resonance								
Huan Chen (S)	C	National High Magnetic Field Laboratory (NHMFL)	Ion Cyclotron Resonance								
Amy McKenna (S)	C	National High Magnetic Field Laboratory (NHMFL)	ICR								
Chris Reddy (S)	C	Woods Hole Oceanographic Institution	Geochemistry								
Oliva Pisani (S)	PI	* Florida International University	Southeast Environmental Research Center	South Florida Water Management District			<b>P12584</b>	Bioassays for Determining Bioavailable Dissolved Organic Nitrogen (BDON) in the Caloosahatchee River Water Column	Chemistry, Geochemistry	1	1.33
Joseph Boyer (S)	C	Plymouth State University	Environmental Science & Policy	NSF - National Science Foundation	DEB - Division of Environmental Biology	DEB1237517					
Teresa Coley (S)	C	South Florida Water Management District	Coastal Ecosystems Section	NSF - National Science Foundation	DEB - Division of Environmental Biology	DEB0620409					
William Cooper (S)	C	Florida State University (FSU)	Chemistry and Biochemistry								

# Appendix VI – User Proposals

		Participants (Name, Role, Org., Dept.)		Funding Sources (Funding Agency, Division, Award #)			Proposal #	Proposal Title	Discipline	Exp. #	Days Used
Rudolf Jaffe (S)	C	Florida International University	Chemistry and Biochemistry	NSF - National Science Foundation	DEB - Division of Environmental Biology	DEB9910514					
David Podgorski (S)	C	University of New Orleans	Department of Chemistry								
Cassandra Thomas (S)	C	South Florida Water Management District	Coastal Ecosystem Services								
Phoebe Zito (P)	C	Florida State University (FSU)	Earth, Ocean and Atmospheric Science								
Lissa Anderson (S)	PI	National High Magnetic Field Laboratory (NHMFL)	ICR	No other support (i.e. this experiment is entirely supported by NHMFL users services via its core grant)			<b>P12571</b>	Method Development (fETD, CID, CAD)	Biology, Biochemistry, Biophysics	2	25.58
Greg Blakney (S)	C	National High Magnetic Field Laboratory (NHMFL)	ICR								
Caroline DeHart (P)	C	Northwestern University	Proteomics Center of Excellence								
Jean-Jacques Dunyach (S)	C	Thermo Fisher Scientific	Instrument Development								
Michelle English (P)	C	University of Virginia	Chemistry								
Chris Hendrickson (S)	C	National High Magnetic Field Laboratory (NHMFL)	Ion Cyclotron Resonance Program								
Nate Kaiser (S)	C	National High Magnetic Field Laboratory (NHMFL)	ICR								
Christopher Mullen (S)	C	Thermo Fisher Scientific	Instrument Development								
Carol Nilsson (S)	C	University of Texas Medical Branch	Pharmacology and Toxicology								
Jeffrey Shabanowitz (S)	C	University of Virginia	Chemistry								
Donald Smith (S)	C	National High Magnetic Field Laboratory	ICR								

# Appendix VI – User Proposals

Participants (Name, Role, Org., Dept.)		Funding Sources (Funding Agency, Division, Award #)			Proposal #	Proposal Title	Discipline	Exp. #	Days Used		
(NHMFL)											
John Syka (S)	C	Thermo Fisher Scientific	Research and Development								
Chad Weisbrod (S)	C	National High Magnetic Field Laboratory (NHMFL)	ICR								
Rafael Bruschweiler (S)	PI	Ohio State University	CCIC	NIH - National Institutes of Health	NIGMS – National Institute of General Medical Sciences	GM066041	<b>P12560</b>	A Combined MS/NMR Strategy for New Metabolite Identification in Complex Mixtures	Chemistry, Geochemistry	1	2.5
Lei Bruschweiler-Li (S)	C	Ohio State University	CCIC	University of Florida-SECIM							
Lidong He (G)	C	National High Magnetic Field Laboratory (NHMFL)	Chemistry								
Dawei Li (P)	C	Florida State University (FSU)	Chemistry								
Alan Marshall (S)	C	National High Magnetic Field Laboratory (NHMFL)	ICR								
Arpad Somogyi (S)	C	Ohio State University	Office of Research, Campus Chemical Instrumentation Center (CCIC)								
Cheng Wang (G)	C	The Ohio State University	Department of Chemistry and Biochemistry								
Luis Echegoyen (S)	PI	University of Texas, El Paso	Chemistry	NSF - National Science Foundation	DMR – Division of Materials Research	DMR 12-05302	<b>P12547</b>	Identification of New Uranium-based and Transition Metal Endohedral Fullerenes	Chemistry, Geochemistry	2	42.5
Laura Abella (S)	C	The Public University of Tarragona	aDepartament de Química Física i Inorgànica,	NSF - National Science Foundation	CHE – Division of Chemistry	CHE 14-08865					
David Buck (G)	C	University of Texas, El Paso	Department of Chemistry	NSF - National Science Foundation	DMR – Division of Materials Research	DMR 12-05302					
Edison Castro (G)	C	University of Texas, El Paso	Chemistry	NSF - National Science Foundation		ACS Scellence 1565063					
Maira Cerón (G)	C	University of Texas, El Paso	Department of Chemistry	NSF - National Science Foundation	DMR – Division of Materials Research	DMR 1205302					

# Appendix VI – User Proposals

		Participants (Name, Role, Org., Dept.)		Funding Sources (Funding Agency, Division, Award #)		Proposal #	Proposal Title	Discipline	Exp. #	Days Used
Paul Dunk (S)	C	National High Magnetic Field Laboratory (NHMFL)	Chemistry and Biochemistry							
Marc Mulet Gas (P)	C	National High Magnetic Field Laboratory (NHMFL)	Ion Cyclotron Resonance							
Josep Poblet (S)	C	Rovira i Virgili University	Departament de Química Física i Inorgànica							
Antonio Rodriguez-Fortea (S)	C	The Public University of Tarragona	Departament de Química Física i Inorgànica							
Fernando Rosario-Ortiz (S)	PI	University of Colorado, Boulder	Environmental Engineering	Water Research Foundation		<b>P11490</b>	Characterization of organic nitrogen in wildfire impacted soils and water	Chemistry, Geochemistry	1	0.33
Kaelin Cawley (S)	C	University of Colorado, Boulder	Hydrologic Sciences	DOE - Department of Energy	DE-SC0007144					
William Cooper (S)	C	Florida State University (FSU)	Chemistry and Biochemistry	DOE - Department of Energy	DE-SC0012272					
Amanda Hohner (G)	C	University of Colorado, Boulder	Civil, Environmental and Architectural Engineering	NSF - National Science Foundation	14-53906					
Julie Korak (G)	C	University of Colorado, Boulder	Civil, Environmental and Architectural Engineering							
David Podgorski (S)	C	University of New Orleans	Department of Chemistry							
Andreas Kappler (S)	PI	Eberhard Karls University of Tübingen	Center for Applied Geosciences	NSF - National Science Foundation	SusChEM 451494	<b>P11473</b>	Effect of the composting process on the chemical nature of the biochar	Biology, Biochemistry, Biophysics	1	0.5
Sebastian Behrens (S)	C	University of Minnesota, Twin Cities	Department of Civil, Environmental, and Geo-Engineering	BMBF						
Thomas Borch (S)	C	Colorado State University	Soil and Crop Science	Food Research Initiative Competitive						

# Appendix VI – User Proposals

		Participants (Name, Role, Org., Dept.)		Funding Sources (Funding Agency, Division, Award #)		Proposal #	Proposal Title	Discipline	Exp. #	Days Used
Benny Chefetz (S)	C	Hebrew University of Jerusalem	Agriculture, Food and Environment	Eberhard Karls University of Tübingen			EC Grant ESTEEM2			
Huan Chen (S)	C	National High Magnetic Field Laboratory (NHMFL)	Ion Cyclotron Resonance							
Pellegrino Conte (S)	C	University of Palermo	Dipartimento di Scienze Agrarie, Alimentari e Forestali							
Alba Dieguez-Alonso (S)	C	Technical University of Berlin	Institute of Energy Engineering							
Korth Elliott (G)	C	University of New Hampshire	Molecular, Cellular and Biomedical Sciences							
Nikolas Hagemann (G)	C	Eberhard Karls University of Tübingen	Center for Applied Geosciences, Geomicrobiology							
Johannes Harter (S)	C	Eberhard Karls University of Tübingen	Center for Applied Geosciences							
Stephen Joseph (S)	C	University of Newcastle upon Tyne	School of Environmental and Life Sciences							
Claudia Kammann (S)	C	Hochschule Geisenheim University	Department of Soil Science and Plant Nutrition							
Andreas Kappler (S)	C	Eberhard Karls University of Tübingen	Center for Applied Geosciences							
Claudia Mayrhofer (S)	C	FELMI-ZFE-Austrian Centre for Electron Microscopy	Centre for Electron Microscopy and Nanoanalysis							
Amy McKenna (S)	C	National High Magnetic Field Laboratory (NHMFL)	ICR							
Martin Obst (S)	C	University of Bayreuth	BayCEER Analytics,							
Silvia Orsetti (S)	C	Eberhard Karls University of Tübingen	Environmental Mineralogy and Chemistry							

# Appendix VI – User Proposals

Participants (Name, Role, Org., Dept.)		Funding Sources (Funding Agency, Division, Award #)			Proposal #	Proposal Title	Discipline	Exp. #	Days Used		
Hans-Peter Schmidt (S)	C	Ithaca Institute	Ithaca Institute for Carbon Strategies								
Edisson Subdiaga (G)	C	Eberhard Karls University of Tübingen	Center for Applied Geoscience, Environmental Mineralogy and Chemistry								
Sarasadat Taherymoosavi (S)	C	University of New South Wales	School of Environmental and Life Sciences, Chemistry								
Krisztina Varga (S)	C	University of Wyoming	Department of Chemistry								
Robert Young (S)	C	Colorado State University	Soil & Crop Sciences								
Donald Smith (S)	PI	National High Magnetic Field Laboratory (NHMFL)	ICR	NSF - National Science Foundation	CHE – Division of Chemistry	1016942	<b>P11461</b>	Optimization of excitation, transfer, accumulation, and detection of petroleum by FT-ICR MS at 21T	Magnets, Materials, Testing, Instrumentation	2	21.33
Amy McKenna (S)	C	National High Magnetic Field Laboratory (NHMFL)	ICR								
Donald Smith (S)	C	National High Magnetic Field Laboratory (NHMFL)	ICR								
Chris Hendrickson (S)	PI	National High Magnetic Field Laboratory (NHMFL)	Ion Cyclotron Resonance Program	No other support (i.e. this experiment is entirely supported by NHMFL users services via its core grant)			<b>P11453</b>	Repair and maintenance of FT ICR MS instruments .Hardware and Software Development	Magnets, Materials, Testing, Instrumentation	10	75.83
Lissa Anderson (S)	C	National High Magnetic Field Laboratory (NHMFL)	ICR								
Greg Blakney (S)	C	National High Magnetic Field Laboratory (NHMFL)	ICR								
Chris Hendrickson (S)	C	National High Magnetic Field Laboratory (NHMFL)	Ion Cyclotron Resonance Program								

# Appendix VI – User Proposals

Participants (Name, Role, Org., Dept.)		Funding Sources (Funding Agency, Division, Award #)		Proposal #	Proposal Title	Discipline	Exp. #	Days Used	
Amy McKenna (S)	C	National High Magnetic Field Laboratory (NHMFL)	ICR						
Steven Rowland (S)	C	National High Magnetic Field Laboratory (NHMFL)	Chemistry						
Donald Smith (S)	C	National High Magnetic Field Laboratory (NHMFL)	ICR						
Chad Weisbrod (S)	C	National High Magnetic Field Laboratory (NHMFL)	ICR						
Chandra Saravanan (S)	PI	Reliance Industries Limited	R&D	Reliance	<b>P11448</b>	Future Fuels Institute-Proprietary	Chemistry, Geochemistry	3	11.67
Martha Chacon (P)	C	National High Magnetic Field Laboratory (NHMFL)	Ion Cyclotron Resonance						
Ramachandra Chakravarthy (S)	C	Reliance Industries Limited	Analytical Division						
Mandan Chidambaram (S)	C	Reliance Industries Limited	Biofuels						
Jagdish Kedia (S)	C	Reliance Industries Limited	Reliance Corporate Park						
Anu Krishnan (S)	C	Reliance Industries Limited	Analytical Division						
Priscila Lalli (S)	C	National High Magnetic Field Laboratory (NHMFL)	ICR						
Vladislav Lobodin (S)	C	National High Magnetic Field Laboratory (NHMFL)	Future Fuels Institute						
Jie Lu (T)	C	National High Magnetic Field Laboratory	ICR						



# Appendix VI – User Proposals

Participants (Name, Role, Org., Dept.)		Funding Sources (Funding Agency, Division, Award #)			Proposal #	Proposal Title	Discipline	Exp. #	Days Used
(NHMFL)									
Jonathan Putman (G)	C	National High Magnetic Field Laboratory (NHMFL)	Ion Cyclotron Resonance User Facility						
Ryan Rodgers (S)	C	National High Magnetic Field Laboratory (NHMFL)	ICR						
Steven Rowland (S)	C	National High Magnetic Field Laboratory (NHMFL)	Chemistry						
Mayuresh Sahasrabudhe (S)	C	Reliance Industries Limited	Petroleum						
David Singh (S)	C	Reliance Industries Limited	Analytical Research						
Pierre Giusti (S)	PI	Total	Research & Technology	OTotal	<b>P11447</b>	Future Fuels Institute-Proprietary	Chemistry, Geochemistry	1	3.83
Carlos Afonso (S)	C	Normandy University	Chemistry	European Regional Development Fund					
Mathilde Farenc (G)	C	University of Rouen	Chemistry	Re'gion Haute Normandie					
Gaelle Jousset (S)	C	Total	Research & Technology	Labex SynOrg					
Priscila Lalli (S)	C	National High Magnetic Field Laboratory (NHMFL)	ICR						
Vladislav Lobodin (S)	C	National High Magnetic Field Laboratory (NHMFL)	Future Fuels Institute						
Jie Lu (T)	C	National High Magnetic Field Laboratory (NHMFL)	ICR						
Caroline Mangote (S)	C	Total	Research & Technology						
David Podgorski (S)	C	University of New Orleans	Department of Chemistry						

# Appendix VI – User Proposals

Participants (Name, Role, Org., Dept.)		Funding Sources (Funding Agency, Division, Award #)			Proposal #	Proposal Title	Discipline	Exp. #	Days Used	
Jonathan Putman (G)	C	National High Magnetic Field Laboratory (NHMFL)	Ion Cyclotron Resonance User Facility							
Eleanor Riches (S)	C	Waters Corporation	Mass Spectrometry							
Ryan Rodgers (S)	C	National High Magnetic Field Laboratory (NHMFL)	ICR							
Steven Rowland (S)	C	National High Magnetic Field Laboratory (NHMFL)	Chemistry							
Omics LLC (S)	PI	Omics, LLC	Omics	Omics, LLC		<b>P11443</b>	OMICS	Chemistry, Geochemistry	1	2
Luis Echegoyen (S)	PI	University of Texas, El Paso	Chemistry	NSF - National Science Foundation	CHE – Division of Chemistry	CHE-1408865	<b>P09516</b>	Identification of C70-based adducts for organic photovoltaics	1	0.5
Edison Castro (G)	C	University of Texas, El Paso	Chemistry					Biology, Biochemistry, Biophysics		
Maira Cerón (G)	C	University of Texas, El Paso	Department of Chemistry							
Paul Dunk (S)	C	National High Magnetic Field Laboratory (NHMFL)	Chemistry and Biochemistry							
Marc Mulet Gas (P)	C	National High Magnetic Field Laboratory (NHMFL)	Ion Cyclotron Resonance							
Venkata Nevi (S)	C	Oak Ridge National Laboratory	ORNL							
Heath Fleming (S)	PI	HK Petroleum, Ltd.	Bulk Sales	No other support (i.e. this experiment is entirely supported by NHMFL users services via its core grant)	DMR – Division of Materials Research		<b>P08465</b>	Characterization of Municipal Solid Waste Pyrolysis Oil by FT-ICR MS	1	3.33
Ryan Rodgers (S)	C	National High Magnetic Field Laboratory (NHMFL)	ICR							
Rebecca Ware (G)	C	National High Magnetic Field Laboratory (NHMFL)	Chemistry							

# Appendix VI – User Proposals

Participants (Name, Role, Org., Dept.)		Funding Sources (Funding Agency, Division, Award #)		Proposal #	Proposal Title	Discipline	Exp. #	Days Used		
Ryan Rodgers (S)	PI	National High Magnetic Field Laboratory (NHMFL)	ICR	No other support (i.e. this experiment is entirely supported by NHMFL users services via its core grant)	DMR – Division of Materials Research	P08400	Photochemically-Induced Weathering of Interfacial Material Isolated from Petroleum	Chemistry, Geochemistry	1	1
Tessa Bartges (U)	C	National High Magnetic Field Laboratory (NHMFL)	ICR							
Amy Clingenpeel (G)	C	National High Magnetic Field Laboratory (NHMFL)	Chemistry							
Jackie Jarvis (S)	C	New Mexico State University	Chemical Analysis and Instrumentation Laboratory							
Joshua Johnson (U)	C	Gardner-Webb University	Natural Sciences							
David Podgorski (S)	C	University of New Orleans	Department of Chemistry							
Emma Spencer (P)	C	Florida State University (FSU)	EOAS							
Matthew Tarr (S)	C	University of New Orleans	Department of Chemistry							
Phoebe Zito (P)	C	Florida State University (FSU)	Earth, Ocean and Atmospheric Science							
Manhoi Hur (T)	PI	Iowa State University	Genetics Development & Cell Biology-LAS	No other support (i.e. this experiment is entirely supported by NHMFL users services via its core grant)		P08367	Application of volcano plots for quantitative visualization and comparison of a set of two spectra obtained by high-resolution mass spectrometric analysis of crude oils	Chemistry, Geochemistry	1	0.5
Amy McKenna (S)	C	National High Magnetic Field Laboratory (NHMFL)	ICR							
Basil Nikolau (S)	C	Iowa State University	Biochemistry, Biophysics and Molecular Biology							
Junkoo Park (S)	C	Georgia Gwinnett College	Math							

# Appendix VI – User Proposals

Participants (Name, Role, Org., Dept.)				Funding Sources (Funding Agency, Division, Award #)	Proposal #	Proposal Title	Discipline	Exp. #	Days Used	
Ryan Rodgers (S)	C	National High Magnetic Field Laboratory (NHMFL)	ICR							
Donald Smith (S)	C	National High Magnetic Field Laboratory (NHMFL)	ICR							
Rebecca Ware (G)	C	National High Magnetic Field Laboratory (NHMFL)	Chemistry							
Eve Wurtele (S)	C	Iowa State University	Genetics Development & Cell Biology-LAS							
Gheorghe Bota (S)	PI	Ohio University	Chemical and Biomolecular Engineering	No other support (i.e. this experiment is entirely supported by NHMFL users services via its core grant)	DMR – Division of Materials Research	<b>P07287</b>	Identification of Corrosive Naphthenic Acids Characterization of Ketones Formed from Ferrous Naphthenate Thermal Decomposition	Chemistry, Geochemistry	1	0.5
Peng Jin (P)	C	Ohio University	Chemical and Biomolecular Engineering							
Logan Krajewski (G)	C	National High Magnetic Field Laboratory (NHMFL)	Chemistry and Biochemistry							
Vladislav Lobodin (S)	C	National High Magnetic Field Laboratory (NHMFL)	Future Fuels Institute							
Winston Robbins (T)	C	Win Consulting Services	Petroleum Separations							
Josep Poblet (S)	PI	Rovira i Virgili University	Departament de Química Física i Inorgànica	Spanish Ministry of Science and Innovation		<b>P07275</b>	Trimetallic nitride endohedral metallofullerenes	Chemistry, Geochemistry	1	2.5
Laura Abella (S)	C	The Public University of Tarragona	aDepartament de Qu`ímica F`isica i Inorg`ànica,							
Paul Dunk (S)	C	National High Magnetic Field Laboratory (NHMFL)	Chemistry and Biochemistry							
Nate Kaiser (S)	C	National High Magnetic Field Laboratory	ICR							

# Appendix VI – User Proposals

Participants (Name, Role, Org., Dept.)		Funding Sources (Funding Agency, Division, Award #)		Proposal #	Proposal Title	Discipline	Exp. #	Days Used
(NHMFL)								
Harold Kroto (S)	C	Florida State University (FSU)	Chemistry					
Alan Marshall (S)	C	National High Magnetic Field Laboratory (NHMFL)	ICR					
Marc Mulet Gas (P)	C	National High Magnetic Field Laboratory (NHMFL)	Ion Cyclotron Resonance					
Yusuke Nishiyama (S)	C	JEOL, Ltd.	Protein Tech Group					
Antonio Rodriguez-Fortea (S)	C	The Public University of Tarragona	Departament de Química Física i Inorganica					
<b>Total Proposals:</b>							<b>Experiments:</b>	<b>Days:</b>
96							136	1,120.00

\* = A new PI for the reporting year.

PI = Principal Investigator; C = Collaborator

S = Senior Personnel; P = Postdoc; G = Graduate Student; U = Undergraduate Student; T = Technician, programmer

# Appendix VI – User Proposals

Participants (Name, Role, Org., Dept.)			Funding Sources (Funding Agency, Division, Award #)			Proposal #	Proposal Title	Discipline	Exp. #	Days Used
Hadi Mohammadigoushki (S)	PI *	Florida State University (FSU)	Chemical and Biomedical Engineering	FSU		P17560	Dynamics and structural characterization of living polymers via NMR spectroscopy	Engineering	1	14
Samuel Grant (S)	C	NHMFL	Chemical & Biomedical Engineering NMR							
Sungsool Wi (S)	C	NHMFL								
Eduard Chekmenev (S)	PI	Vanderbilt University	Institute of Imaging Science	FSU		P17460	Gramicidin Ion Binding and Conductance: New Insights from 17O solid state NMR at 35.2T field.	Biology, Biochemistry, Biophysics	1	1
Tim Cross (S)	C	NHMFL	NHMFL/Chemistry & Biochemistry							
Zhehong Gan (S)	C	NHMFL	NHMFL							
Ivan Hung (S)	C	NHMFL	CIMAR/NMR							
Joana Paulino (P)	C	NHMFL	CIMAR							
Xiaoling Wang (P)	C	NHMFL	NMR							
Tim Cross (S)	PI	NHMFL	NHMFL/Chemistry & Biochemistry	FSU		P17459	M2 from Influenza A: Advancing the understanding of it's multiple functions and drug binding to medically relevant S31N mutant	Biology, Biochemistry, Biophysics	2	12
Riqiang Fu (S)	C	NHMFL	NMR	NIH - National Institutes of Health	NIAID – National Institute of Allergy and Infectious Diseases	AI119178				
Ivan Hung (S)	C	NHMFL	CIMAR/NMR	NIH - National Institutes of Health	NIAID – National Institute of Allergy and Infectious Diseases	AI023007				
Frederic Mentink (S)	C	NHMFL	NMR Division							
Yong Yang (S)	PI *	Xiamen University	Department of Chemistry	Xiamen University		P17445	High Field Solid-State NMR Studies on Na-Ion Rechargeable Battery Materials	Chemistry, Geochemistry	1	5
Riqiang Fu (S)	C	NHMFL	NMR							
Chang Hyun Lee (S)	PI	Dankook University	Energy Engineering Department	No other support (i.e. this experiment is entirely supported by NHMFL users services via its core grant)		P17436	Solid-state NMR characterization of nanodispersed polymeric membrane materials for energy generation and valued chemicals production	Chemistry, Geochemistry	3	17
Se Youn Pyo (G)	C	Dankook University	Energy engineering							
Sungsool Wi (S)	C	NHMFL	NMR							
Oc Hee Han (S)	PI	Korea Basic Science Institute	Western Seoul Center	National Research Council of Science and Technology in Korea		P17424	Relationship between Photoluminescence (PL) and Structure of	Chemistry, Geochemistry	1	6

# Appendix VI – User Proposals

	Participants (Name, Role, Org., Dept.)		Funding Sources (Funding Agency, Division, Award #)		Proposal #	Proposal Title	Discipline	Exp. #	Days Used
Zhehong Gan (S)	C	NHMFL	NHMFL	National Research Foundation of Korea		CaPbBr <sub>3</sub> and Ca <sub>4</sub> PbBr <sub>6</sub> Perovskite Crystals			
Duk-Young Jung (S)	C	Sungkyunkwan University	Chemistry						
Sonia Waiczies (S)	PI *	Max Delbrück Center for Molecular Medicine in the Helmholtz Association	Berlin Ultrahigh Field Facility	Deutsche Forschungsgemeinschaft	<b>P17420</b>	Fluorine MRI of Experimental Autoimmune Encephalomyelitis at 21.1 Tesla	Biology, Biochemistry, Biophysics	2	9
Paula Delgado (S)	C	Max Delbrueck Center for Molecular Medicine	Berlin Ultrahigh Field Facility	NHMFL VSP - Visiting Scientist Program					
Andre Kuehne (S)	C	MRI.TOOLS GmbH	MRI Coils	Deutsche Forschungsgemeinschaft					
Jason Millward (S)	C	Max Delbrueck Center for Molecular Medicine	Berlin Ultrahigh Field Facility						
Thoralf Niendorf (S)	C	Max Delbrück Center for Molecular Medicine in the Helmholtz Association	Berlin Ultrahigh Field Facility						
Andreas Pohlmann (S)	C	Max Delbrück Center for Molecular Medicine in the Helmholtz Association	Berlin Ultrahigh Field Facility						
Christian Prinz (G)	C	Max Delbrueck Center for Molecular Medicine	Berlin Ultrahigh Field Facility						
Jens Rosenberg (S)	C	NHMFL	NMR						
Ludger Starke (S)	C	Max Delbrueck Center for Molecular Medicine	Berlin Ultrahigh Field Facility						
Helmar Waiczies (S)	C	MRI.TOOLS GmbH	R&D						
William Pomerantz (S)	PI *	University of Minnesota, Twin Cities	Chemistry	Lilly research academic partnership grant	<b>P17419</b>	CSA Determination of Fluorinated Amino Acids in Proteins	Biology, Biochemistry, Biophysics	1	2
Riqiang Fu (S)	C	NHMFL	NMR						
Peter Ycas (G)	C	University of Minnesota, Twin Cities	Chemistry						
Justin Kennemur (S)	PI *	Florida State University (FSU)	Chemistry and Biochemistry	FSU	<b>P17413</b>	Probing By Variable Temperature MAS	Condensed Matter Physics	2	6

# Appendix VI – User Proposals

	Participants (Name, Role, Org., Dept.)			Funding Sources (Funding Agency, Division, Award #)			Proposal #	Proposal Title	Discipline	Exp. #	Days Used
Naresh Dalal (S)	C	NHMFL	Chemistry					NMR the Mechanism of Glass Transition in Precisely Designed Polymers			
Riqiang Fu (S)	C	NHMFL	NMR								
Kwang Hun Lim (S)	PI	East Carolina University	Chemistry	NIH - National Institutes of Health		NS097490	<b>P17409</b>	Solid-state NMR Structural Characterizations of Polymorphic Transthyretin Amyloids	Biology, Biochemistry, Biophysics	1	7
Zhehong Gan (S)	C	NHMFL	NHMFL								
Ivan Hung (S)	C	NHMFL	CIMAR/NMR								
Ravi Hadimani (S)	PI *	Virginia Commonwealth University	Mechanical and Nuclear Engineering	Virginia Commonwealth University			<b>P17390</b>	Improvement of T2 contrast in MRI using ferromagnetic gadolinium based nanoparticles	Magnets, Materials, Testing, Instrumentation	2	2
Shivakumar Hunagund (G)	C	Virginia Commonwealth University	Dept. of Mechanical and Nuclear Engineering								
Jens Rosenberg (S)	C	NHMFL	NMR								
Edward Agyare (S)	PI	Florida Agricultural and Mechanical University	Pharmaceutics	NIH - National Institutes of Health	NCI – National Cancer Institute	CA192990	<b>P17382</b>	Development of theranostic liposomal nanoparticle to target pancreatic cancer in patient-derived xenograft mouse model	Biology, Biochemistry, Biophysics	1	2
Kevin Affram (G)	C	Florida Agricultural and Mechanical University	College of Pharmacy and Pharmaceutical Sciences	NIH - National Institutes of Health	NIMHD - National Institute on Minority Health and Health Disparities	MH007582					
Sunil Krishnan (S)	C	University of Texas, MD Anderson Cancer Center	Radiation Oncology								
Renee Reams (S)	C	Florida A & M University	College of Pharmacy and Pharmaceutical Sciences								
Jens Rosenberg (S)	C	NHMFL	NMR								
Mandip Singh (S)	C	Florida Agricultural and Mechanical University	College of Pharmacy and Pharmaceutical Sciences								
Taylor Smith (G)	C	Florida Agricultural and Mechanical University	College of Pharmacy and Pharmaceutical Sciences								



# Appendix VI – User Proposals

	Participants (Name, Role, Org., Dept.)			Funding Sources (Funding Agency, Division, Award #)			Proposal #	Proposal Title	Discipline	Exp. #	Days Used	
Joseph Ippolito (S)	PI	*	Washington University School of Medicine in St. Louis	Radiology	No other support (i.e. this experiment is entirely supported by NHMFL users services via its core grant)			<b>P17381</b>	Characterization of biosynthetic lactate metabolism in cancer	Biology, Biochemistry, Biophysics	2	6
Sungsool Wi (S)	C		NHMFL	NMR								
Cecil Dybowski (S)	PI	*	University of Delaware	Chemistry and Biochemistry	NSF - National Science Foundation	DMR – Division of Materials Research	1608594	<b>P17354</b>	Assessing the potential of high-field, natural abundance 67Zn solid-state NMR for understanding the reactivity of ZnO-based pigments in paint films	Chemistry, Geochemistry	1	6
Silvia Centeno (S)	C		The Metropolitan Museum of Art	Scientific Research								
Valeria Di Tullio (P)	C		The Metropolitan Museum of Art	Scientific Research								
Ivan Hung (S)	C		NHMFL	CIMAR/NMR								
Ilya Litvak (S)	C		NHMFL	CIMAR/NMR								
Joana Paulino (P)	C		NHMFL	CIMAR								
Xiaoling Wang (P)	C		NHMFL	NMR								
Nicholas Zumbulyadis (S)	C		independent Scholar and Consultant	Consultancy								
Tuo Wang (S)	PI	*	Louisiana State University	Chemistry	Louisiana State University			<b>P17348</b>	Structure and Packing of Complex Carbohydrates in Native Plant and Fungal Cell Walls from Solid-State DNP-NMR	Biology, Biochemistry, Biophysics	4	21
Zhehong Gan (S)	C		NHMFL	NHMFL								
Xue Kang (P)	C		Louisiana State University	Chemistry								
Alex Kirui (G)	C		Louisiana State University	Chemistry								
Joanna Long (S)	C		University of Florida	Biochemistry & Molecular Biology								
Frederic Mentink (S)	C		NHMFL	NMR Division								
Benito Marinas (S)	PI	*	University of Illinois at Urbana-Champaign	Civil and Environmental Engineering	University of Illinois Urbana-Champaign			<b>P17334</b>	Determination of fluoride chemical environment on calcium hydroxyapatite nanoparticles of different crystallinities – distinguishing the dominant mechanism(s) of fluoride removal	Engineering	1	3
Daniel Mosiman (G)	C		University of Illinois at Urbana-Champaign	Civil and Environmental Engineering	NSF - National Science Foundation		2015197351					
Sophia Hayes (S)	PI		Washington University in St. Louis	Chemistry	NSF - National Science Foundation	CHE – Division of Chemistry	1606982	<b>P17330</b>	Elucidation of Metal Oxide Thin Films Using High Magnetic Fields	Biology, Biochemistry, Biophysics	2	15

# Appendix VI – User Proposals

		Participants (Name, Role, Org., Dept.)		Funding Sources (Funding Agency, Division, Award #)			Proposal #	Proposal Title	Discipline	Exp. #	Days Used
Yvonne Afriyie (G)	C	Washington University in St. Louis	Chemistry								
Douglas Keszler (S)	C	Oregon State University	Chemistry								
Robert Marti (G)	C	Washington University in St. Louis	Chemistry								
Daphna Shimon (P)	C	Washington University in St. Louis	Chemistry								
Ashley Blue (T)	PI *	NHMFL	NHMFL	No other support (i.e. this experiment is entirely supported by NHMFL users services via its core grant)			<b>P16319</b>	NMR System Maintenance	Biology, Biochemistry, Biophysics	7	99.5
Thierry Dubroca (P)	C	NHMFL	EMR								
Riqiang Fu (S)	C	NHMFL	NMR								
Zhehong Gan (S)	C	NHMFL	NHMFL								
Frederic Mentink (S)	C	NHMFL	NMR Division								
Johan van Tol (S)	C	NHMFL	EMR								
Sungsool Wi (S)	C	NHMFL	NMR								
Sungsool Wi (S)	PI	NHMFL	NMR	No other support (i.e. this experiment is entirely supported by NHMFL users services via its core grant)			<b>P16311</b>	Development of the state-of-the-art solid-state NMR methods suitable at ultrahigh magnetic fields and MAS spinning rates	Biology, Biochemistry, Biophysics	13	64
Tim Cross (S)	C	NHMFL	NHMFL/Chemistry & Biochemistry	Israel Science Foundation							
Lucio Frydman (S)	C	Weizmann Institute of Science	Dept. Chemical Physics								
Yiseul Shin (G)	C	Florida State University (FSU)	Chemistry								
Liliya Vugmeyster (S)	PI	University of Colorado, Denver	Chemistry	NIH - National Institutes of Health	NIGMS – National Institute of General Medical Sciences	GM111681	<b>P16309</b>	Dynamics of amyloid-beta fibrils by deuterium NMR	Biology, Biochemistry, Biophysics	4	12
Isaac Falconer (U)	C	University of Colorado, Denver	Chemistry								
Dmitry Ostrovsky (S)	C	University of Alaska, Anchorage	Mathematics								
Pulickel Ajayan (S)	PI *	Rice University	Materials Science and Nano Engineering	DOD - Department of Defense	U.S. Air Force	BAA-AFOSR-2013-0001	<b>P16305</b>	19F NMR for Fluorinated Boron Nitride	Magnets, Materials, Testing,	2	1

# Appendix VI – User Proposals

		Participants (Name, Role, Org., Dept.)		Funding Sources (Funding Agency, Division, Award #)			Proposal #	Proposal Title	Discipline	Exp. #	Days Used	
Lawrence Alemany (S)	C	Rice University	Shared Equipment Authority						Instrumentation			
Sruthi Radhakrishnan (G)	C	Rice University	Materials Science and Nano Engineering									
Christina Tang (S)	PI *	Virginia Commonwealth University	Chemical and Life Sciences Engineering	No other support (i.e. this experiment is entirely supported by NHMFL users services via its core grant)			P16239	Characterization of Multifunctional Nanoreactor Diffusion by Pulsed Field Gradient NMR	Engineering	5	17	
Andrew Harrison (G)	C	Virginia Commonwealth University	Chemical and Life Sciences Engineering									
Sungsool Wi (S)	C	NHMFL	NMR									
Fang Tian (S)	PI	Pennsylvania State University	Biochemistry and Molecular Biology, Penn State Medical School	NIH - National Institutes of Health	NIGMS – National Institute of General Medical Sciences	GM105963	P16233	Structure Determination of the Transmembrane Domain of Human Amyloid Precursor Protein Binding Receptor LR11 (sorLA) in a Biological Membrane	Biology, Biochemistry, Biophysics	9	61	
Riqiang Fu (S)	C	NHMFL	NMR	NIH - National Institutes of Health	NIGMS – National Institute of General Medical Sciences	GM011059						
Joana Paulino (P)	C	NHMFL	CIMAR	Pennsylvania Department of Health		Tobacco CURE funds						
Avigdor Leftin (P)	PI *	Weizmann Institute of Science	Chemical Physics	NIH - National Institutes of Health	NCI – National Cancer Institute	1F32CA206277-01	P16232	Ultra-high-field iron MRI microscopy of macrophage infiltration in breast cancer	Biology, Biochemistry, Biophysics	3	5	
Jens Rosenberg (S)	C	NHMFL	NMR									
Elan Eisenmesser (S)	PI	University of Colorado, Denver	Biochemistry & Molecular Genetics	NIH - National Institutes of Health	NIGMS – National Institute of General Medical Sciences	GM107262	P16165	Engineering enzyme function through dynamics.	Biology, Biochemistry, Biophysics	8	86	
Michael Holliday (G)	C	University of Colorado, Denver	School of Medicine									
Zhong Chen (S)	PI *	Xiamen University	Electronic Science	NSFC (National Natural Science Foundation of China)			U1632274	P16159	Ultrafast high-resolution magnetic resonance spectroscopy at high fields	Biology, Biochemistry, Biophysics	14	68.5
Xiaoyan Ding (P)	C	Pennsylvania State University	Biochemistry and Molecular Biology									
Riqiang Fu (S)	C	NHMFL	NMR									
Yuqing Huang (S)	C	Xiamen University	Electronic Science									

# Appendix VI – User Proposals

	Participants (Name, Role, Org., Dept.)		Funding Sources (Funding Agency, Division, Award #)			Proposal #	Proposal Title	Discipline	Exp. #	Days Used	
Kaiyu Wang (G)	C	Xiamen University	Electronic Science								
Zhiyong Zhang (P)	C	Weizman Institute of Science	Chemical Physics								
Samuel Grant (S)	PI	NHMFL	Chemical & Biomedical Engineering	No other support (i.e. this experiment is entirely supported by NHMFL users services via its core grant)		<b>P16147</b>	Maintenance on the 500 MHz at Engineering School	Magnets, Materials, Testing, Instrumentation	1	30	
Shannon Helsper (T)	C	NHMFL	NMR								
Jens Rosenberg (S)	C	NHMFL	NMR								
Bruce Bunnell (S)	PI *	Tulane University	Pharmacology	NHMFL UCGP - User Collaboration Grants Program		<b>P16124</b>	Attenuation of Experimental Autoimmune Encephalomyelitis Model of Multiple Sclerosis by 3D-organized Adipose-derived Human Mesenchymal Stem Cells	Biology, Biochemistry, Biophysics	1	26	
Ghoncheh Amouzandeh (G)	C	Florida State University (FSU)	Physics								
Samuel Grant (S)	C	NHMFL	Chemical & Biomedical Engineering								
Teng Ma (S)	C	Florida State University (FSU)	Chemistry & Biomedical Engineering								
Jens Rosenberg (S)	C	NHMFL	NMR								
Samuel Grant (S)	PI	NHMFL	Chemical & Biomedical Engineering	NHMFL UCGP - User Collaboration Grants Program	227000-520-030759	<b>P16122</b>	Electrical Properties Derivation using Radiofrequency Field Propagation in Ultra-High Field MRI	Biology, Biochemistry, Biophysics	5	35	
Ghoncheh Amouzandeh (G)	C	Florida State University (FSU)	Physics								
Scott Boebinger (U)	C	Florida State University (FSU)	Chemical and Biomedical Engineering								
David Hike (G)	C	Florida State University (FSU)	Chemical and Biomedical Engineering								
Abdol Aziz Ould Ismail (T)	C	University of Pennsylvania	Department of Radiology								
Jens Rosenberg (S)	C	NHMFL	NMR								
Victor Wong (U)	C	Florida State University (FSU)	Chemical and Biomedical Engineering								
Tim Cross (S)	PI	NHMFL	NHMFL/Chemistry & Biochemistry	NIH - National Institutes of Health	NIAID – National Institute of Allergy and Infectious Diseases	A119178	<b>P16117</b>	Structural Characterization of CwsA with Solid-State NMR	Biology, Biochemistry, Biophysics	49	321.5
Huajun Qin (T)	C	Florida State	Chemistry &								

# Appendix VI – User Proposals

		Participants (Name, Role, Org., Dept.)		Funding Sources (Funding Agency, Division, Award #)		Proposal #	Proposal Title	Discipline	Exp. #	Days Used
Rongfu Zhang (P)	C	University (FSU)	Biochemistry							
Ramesh Badisa (S)	PI *	NHMFL	NHMFL							
		Florida Agricultural and Mechanical University	College of Pharmacy and Pharmaceutical Sciences	No other support (i.e. this experiment is entirely supported by NHMFL users services via its core grant)		P16090	Identification of Biochemical Changes in Cocaine-treated PC12 Cells	Biology, Biochemistry, Biophysics	3	37
Carl Goodman (S)	C	Florida Agricultural and Mechanical University	Pharmacy							
Samuel Grant (S)	C	NHMFL	Chemical & Biomedical Engineering							
Elizabeth Mazzio (P)	C	Florida Agricultural and Mechanical University	FAMU College of Pharmacy & Pharmacological Sciences							
Jens Rosenberg (S)	C	NHMFL	NMR							
Sungsool Wi (S)	C	NHMFL	NMR							
Katye Fichter (S)	PI *	Missouri State University	Chemistry	Missouri State University		P16080	Gd-doped quantum dots with multimodal imaging capabilities for the detection of motor neuron diseases in vivo	Biology, Biochemistry, Biophysics	1	16.5
Chi-yuan Cheng (S)	PI *	Colgate-Palmolive Company	N/A	Colgate-Palmolive		P16063	Structural and Compositional Characterization of Zn Complex in Toothpaste by High-field Solid-state <sup>67</sup> Zn NMR and <sup>13</sup> C DNP Spectroscopy	Chemistry, Geochemistry	3	14.5
Riqiang Fu (S)	C	NHMFL	NMR	Supported by NHMFL users services via its core grant						
Frederic Mentink (S)	C	NHMFL	NMR Division							
Jun Xu (S)	PI *	Wuhan Institute of Physics & Mathematics, Chinese Academy of Sciences	Wuhan NMR center	National Natural Science Foundation of China	21622311	P16062	Study of active site and reaction intermediates on heterogeneous catalysis by DNP-NMR	Biology, Biochemistry, Biophysics	1	7
Zhehong Gan (S)	C	NHMFL	NHMFL	National Natural Science Foundation of China	21733013					
Qiang Wang (T)	C	Wuhan Institute of Physics & Mathematics, Chinese Academy of Sciences	Wuhan NMR center	National Natural Science Foundation of China	21210005					

# Appendix VI – User Proposals

Participants (Name, Role, Org., Dept.)				Funding Sources (Funding Agency, Division, Award #)			Proposal #	Proposal Title	Discipline	Exp. #	Days Used
				NIH - National Institutes of Health	NIGMS – National Institute of General Medical Sciences	GM122698					
Jose Pinto (S)	PI *	Florida State University (FSU)	Biomedical Sciences	No other support (i.e. this experiment is entirely supported by NHMFL users services via its core grant)			<b>P16052</b>	Allosteric Regulation of Thin Filament Proteins	Biology, Biochemistry, Biophysics	2	24
Jamie Johnston (G)	C	Florida State University (FSU)	Biomedical Science at the College of Medicine								
Mayra Marques (G)	C	Federal University of Rio de Janeiro	Medical Biochemistry Institute								
Guilherme Oliveira (S)	C	Federal University of Rio de Janeiro	Medical Biochemistry Institute								
Sossina Haile (S)	PI *	Northwestern University	Materials Science and Engineering, and Chemistry	NSF - National Science Foundation	DMR – Division of Materials Research	DMR1702139	<b>P16051</b>	19F and 15N Solid-state NMR Investigations of Oxyfluorides and Oxynitrides	Chemistry, Geochemistry	4	37
Po-Hsiu Chien (G)	C	Florida State University (FSU)	Chemistry and Biochemistry								
Yan-Yan Hu (S)	C	Florida State University (FSU)	Chemistry & Biochemistry								
Xiang Li (G)	C	Florida State University (FSU)	Chemistry and Biochemistry								
Tobin Marks (S)	C	Northwestern University	Chemistry								
Mingxue Tang (P)	C	Florida State University (FSU)	Chemistry & Biochemistry								
Wei Wang (S)	PI *	Lanzhou University	State Key Laboratory of Applied Organic Chemistry	Lanzhou University			<b>P16043</b>	Additive-free DNP NMR with the Radical-embedded Porous Organic Materials (Radical-POMs)	Chemistry, Geochemistry	3	10
Zhehong Gan (S)	C	NHMFL	NHMFL								
Ivan Hung (S)	C	NHMFL	CIMAR/NMR								
Frederic Mentink (S)	C	NHMFL	NMR Division								
Wei David Wang (S)	C	Lanzhou University	State Key Laboratory of Applied Organic Chemistry								
Xiaoling Wang (P)	C	NHMFL	NMR								

# Appendix VI – User Proposals

Participants (Name, Role, Org., Dept.)		Funding Sources (Funding Agency, Division, Award #)			Proposal #	Proposal Title	Discipline	Exp. #	Days Used		
Huan-Xiang Zhou (S)	PI	University of Illinois at Chicago	Physics and Chemistry	NIH - National Institutes of Health	NIGMS – National Institute of General Medical Sciences	GM058187	<b>P16037</b>	The binding mechanism of Cdc42 with its intrinsically disordered binding partner WASp GBD	Biology, Biochemistry, Biophysics	4	33
Pieter Smith (P)	C	Florida State University (FSU)	Institute of Molecular Biophysics	NIH - National Institutes of Health	NIGMS – National Institute of General Medical Sciences	GM073002					
Di Wu (P)	C	Florida State University (FSU)	IMB								
Huan-Xiang Zhou (S)	C	University of Illinois at Chicago	Physics and Chemistry								
Frederic Mentink (S)	PI	NHMFL	NMR Division	No other support (i.e. this experiment is entirely supported by NHMFL users services via its core grant)			<b>P16032</b>	Towards more efficient Magic Angle Spinning – Dynamic Nuclear Polarization at 14 T	Chemistry, Geochemistry	1	3
Tim Cross (S)	C	NHMFL	NHMFL/Chemistry & Biochemistry								
Gael De Paepe (S)	C	The French Alternative Energies and Atomic Energy Commission	Institute for Nanoscience and Cryogenics								
Sabine Hediger (S)	C	The French Alternative Energies and Atomic Energy Commission	Institute for Nanoscience and Cryogenics								
Johannes McKay (P)	C	Keysight Technologies	MMIC Microwave								
Johan van Tol (S)	C	NHMFL	EMR								
Shimon Vega (S)	C	Weizmann Institute of Science	Physical Chemistry								
Anant Paravastu (S)	PI	Georgia Institute of Technology	School of Chemical & Biomolecular Engineering	NIH - National Institutes of Health		R01AG045703	<b>P16020</b>	Structure determination of $\beta$ -amyloid oligomers and investigation of their formation pathways	Biology, Biochemistry, Biophysics	12	100
Anant Paravastu (S)	C	Georgia Institute of Technology	School of Chemical & Biomolecular Engineering	NSF - National Science Foundation	DMR – Division of Materials Research	DMR105521					
Xiaoling Wang (P)	C	NHMFL	NMR								
Sungsool Wi (S)	C	NHMFL	NMR								

# Appendix VI – User Proposals

	Participants (Name, Role, Org., Dept.)		Funding Sources (Funding Agency, Division, Award #)			Proposal #	Proposal Title	Discipline	Exp. #	Days Used
Eric Gottwald (S)	PI	Karlsruhe Institute of Technology	Institute for Biological Interfaces (IBG 5)	Heidelberg University			NMR Compatible Bioreactor with a Three Dimensional Cell Culture on Chip-- Application of 23 Na Triple Quantum Filtered NMR and MRI/S methods	Biology, Biochemistry, Biophysics	1	3
William Brey (S)	C	NHMFL	NMR	Karlsruhe Institute of Technology						
Andreas Neubauer (P)	C	Heidelberg University	Physics	Innovation Fund of the Ministry of Science						
Steven Ranner (T)	C	NHMFL	Instrumentation & Operations	Research and the Arts of Baden Wuerttemberg						
Lothar Schad (S)	C	Heidelberg University	Computer Assisted Clinical Medicine							
Victor Schepkin (S)	C	NHMFL	CIMAR							
John Forder (S)	PI	University of Florida	Radiology	NIH - National Institutes of Health	NHLBI – National Heart and Blood Institute	HL122064-01	P16013	MR Microscopy and Fiber Tract Mapping of Isolated Rabbit Hearts at 900MHz	1	18
Steve Blackband (S)	C	University of Florida	CIMAR							
Samuel Grant (S)	C	NHMFL	Chemical & Biomedical Engineering							
Steve Blackband (S)	PI	University of Florida	CIMAR	NHMFL UCGP - User Collaboration Grants Program						
Jeremy Flint (S)	C	University of Florida	Neuroscience				P16012	Cellular Level MR microscopy of Mammalian Cells at 900MHz	1	43.5
Samuel Grant (S)	C	NHMFL	Chemical & Biomedical Engineering							
Brian Hansen (S)	C	University of Aarhus								
Michael Harrington (S)	PI	Huntington Medical Research Institutes	Molecular Neurology	NIH - National Institutes of Health		NS072497				
Nastaren Abad (G)	C	Florida State University (FSU)	Chemical-Biomedical Engineering							
Samuel Grant (S)	C	NHMFL	Chemical & Biomedical Engineering				P16008	Evaluation of Sodium and Metabolic Dysfunction in a Rat Migraine Model	18	76
Dillon Grice (U)	C	Florida State University (FSU)	Chemical and Biomedical Engineering							
Shannon Helsper (T)	C	NHMFL	NMR							
Jens Rosenberg (S)	C	NHMFL	NMR							



# Appendix VI – User Proposals

		Participants (Name, Role, Org., Dept.)		Funding Sources (Funding Agency, Division, Award #)			Proposal #	Proposal Title	Discipline	Exp. #	Days Used
Lucio Frydman (S)	PI	Weizmann Institute of Science	Dept. Chemical Physics	NIH - National Institutes of Health	NICHD - Eunice Kennedy Shriver National Institute of Child Health and Human Development	HD010863	<b>P14983</b>	Magnetic resonance imaging of maternal glycemic state by glucose tolerance test during pregnancy in mice	Biology, Biochemistry, Biophysics	9	32
Ghoncheh Amouzandeh (G)	C	Florida State University (FSU)	Physics	Minerva Project							
Samuel Grant (S)	C	NHMFL	Chemical & Biomedical Engineering	Kimmel Institute for Magnetic Resonance							
Shannon Helsper (T)	C	NHMFL	NMR	Perlman Family Foundation							
Stefan Markovic (P)	C	Weizmann Institute of Science	Department of Chemical Physics	NHMFL UCGP - User Collaboration Grants Program							
Michai Neeman (S)	C	Weizmann Institute of Science	Department of Biological Regulation	NMR							
Jens Rosenberg (S)	C	NHMFL									
Huan-Xiang Zhou (S)	PI	University of Illinois at Chicago	Physics and Chemistry	NIH - National Institutes of Health	NIGMS – National Institute of General Medical Sciences	GM088187-06	<b>P14976</b>	An investigation of macromolecular crowding of an IDP by determination of residue-residue contacts using paramagnetic relaxation enhancement	Biology, Biochemistry, Biophysics	3	16
Archishman Ghosh (G)	C	Florida State University (FSU)	Institute of Molecular Biophysics								
Pieter Smith (P)	C	Florida State University (FSU)	Institute of Molecular Biophysics								
Huan-Xiang Zhou (S)	C	University of Illinois at Chicago	Physics and Chemistry								
Victor Schepkin (S)	PI	NHMFL	CIMAR	Heidelberg University			<b>P14971</b>	Non-invasive assessment of tumors using <sup>17</sup> O labeled glucose	Biology, Biochemistry, Biophysics	2	8
William Brey (S)	C	NHMFL	NMR								
Tilo Glaeser (S)	C	NUKEM Isotopes Imaging GmbH	Trading Isotopes								
Shannon Helsper (T)	C	NHMFL	NMR								
Michael Kievel (S)	C	NUKEM Isotopes Imaging GmbH	Trading Isotopes								
Cathy Levenson (S)	C	Florida State University (FSU)	Biomedical Sciences								

# Appendix VI – User Proposals

	Participants (Name, Role, Org., Dept.)			Funding Sources (Funding Agency, Division, Award #)			Proposal #	Proposal Title	Discipline	Exp. #	Days Used
Andreas Neubauer (P)	C	Heidelberg University	Physics								
Steven Ranner (T)	C	NHMFL	Instrumentation & Operations								
Lothar Schad (S)	C	Heidelberg University	Computer Assisted Clinical Medicine								
Christian Schuch (S)	C	NUKEM Isotopes Imaging GmbH	Trading Isotopes								
Ozge Gunaydin-Sen (S)	PI	Lamar University	Chemistry and Biochemistry	Department of Chemistry and Biochemistry, Lamar University			<b>P14970</b>	Solid-State High Resolution NMR Studies of Ammonia Borane/Polymer Composites	Chemistry, Geochemistry	1	6
Riqiang Fu (S)	C	NHMFL	NMR	Welch Foundation							
Hailong Chen (S)	PI	Georgia Institute of Technology	School of Mechanical Engineering	FSU			<b>P14967</b>	In situ and/or Operando NMR and EPR imaging of energy materials	Chemistry, Geochemistry	13	93
Hailong Chen (S)	C	Georgia Institute of Technology	School of Mechanical Engineering	NSF - National Science Foundation	DMR – Division of Materials Research	DMR1410936					
Xuyong Feng (P)	C	Florida State University (FSU)	Chemistry and Biochemistry	NSF - National Science Foundation	DMR – Division of Materials Research	DMR1508404					
Zhenxing Feng (S)	C	Oregon State University	School of Chemical, Biological, and Environmental Engineering								
Yan-Yan Hu (S)	C	Florida State University (FSU)	Chemistry & Biochemistry								
Jens Rosenberg (S)	C	NHMFL	NMR								
Likai Song (S)	C	NHMFL	EMR								
Mingxue Tang (P)	C	Florida State University (FSU)	Chemistry & Biochemistry								
Wenyu Huang (S)	PI	Iowa State University	Chemistry	NSF - National Science Foundation	CHE – Division of Chemistry	CHE-1507230	<b>P14961</b>	DNP Solid-State MAS NMR Studies of Advanced Catalytic Nanomaterials to Complement Parahydrogen Induced Polarization Studies	Chemistry, Geochemistry	3	16
Clifford Bowers (S)	C	University of Florida	Chemistry	NSF - National Science Foundation	CHE – Division of Chemistry	CHE1607305					
Yong Du (G)	C	University of Florida	Chemistry								
Helena Hagelin-Weaver (S)	C	University of Florida	Chemical Engineering								
Yan-Yan Hu (S)	C	Florida State University (FSU)	Chemistry & Biochemistry								
Wenyu Huang (S)	C	Iowa State University	Chemistry								

# Appendix VI – User Proposals

		Participants (Name, Role, Org., Dept.)		Funding Sources (Funding Agency, Division, Award #)		Proposal #	Proposal Title	Discipline	Exp. #	Days Used
Raghu Maligal-Ganesh (G)	C	Iowa State University	Chemistry							
Frederic Mentink (S)	C	NHMFL	NMR Division							
Evan Wenbo Zhao (G)	C	University of Florida	Chemistry							
Tommy Zhao (G)	C	University of Florida	Chemistry							
Bo Chen (S)	PI	University of Central Florida	Department of Physics	DOD - Department of Defense	U.S. Air Force	<b>P14959</b>	Spherical Assembly of Rous Sarcoma Virus Capsid Proteins	Biology, Biochemistry, Biophysics	5	51
Zhehong Gan (S)	C	NHMFL	NHMFL	University of Central Florida						
Petr Gor'kov (S)	C	NHMFL	CIMAR	No other support (i.e. this experiment is entirely supported by NHMFL users services via its core grant)	FA9550-13-0150					
Ivan Hung (S)	C	NHMFL	CIMAR/NMR							
Xin Qiao (G)	C	University of Central Florida	Physics							
Hans Jakobsen (S)	PI	Aarh	Department of Chemistry	Aarh, Denmark		<b>P14957</b>	Dynamic and Structure NMR Studies of Tetraoxoanions and Gas-Solid Materials Mimicking Environments on Planet Mars	Chemistry, Geochemistry	1	3
Henrik Bildsoe (S)	C	Aarh	Chemistry							
Michael Brorson (S)	C	Haldor Topsoe	Catalysis							
Zhehong Gan (S)	C	NHMFL	NHMFL							
Ivan Hung (S)	C	NHMFL	CIMAR/NMR							
Svend Knak Jensen (S)	C	Aarh	Department of Chemistry							
Likai Song (S)	C	NHMFL	EMR							
Lothar Schad (S)	PI *	Heidelberg University	Computer Assisted Clinical Medicine	Supported by NHMFL users services via its core grant		<b>P14955</b>	Characterization of in vivo 17O relaxation times and the spatiotemporal distribution of H217O in rat brain at 21.1 T by usage of 17O-glucose as precursor	Biology, Biochemistry, Biophysics	1	5
William Brey (S)	C	NHMFL	NMR	Friedrich-Ebert-Stiftung Foundation						
Thomas Budinger (S)	C	Lawrence Livermore National Laboratory	Chair of the Department of BioEngineering	Heidelberg University						
Shannon Helsper (T)	C	NHMFL	NMR							
Cathy Levenson (S)	C	Florida State University (FSU)	Biomedical Sciences							
Andreas Neubauer (P)	C	Heidelberg University	Physics							
Steven Ranner (T)	C	NHMFL	Instrumentation & Operations							
Victor Schepkin (S)	C	NHMFL	CIMAR							

# Appendix VI – User Proposals

	Participants (Name, Role, Org., Dept.)			Funding Sources (Funding Agency, Division, Award #)			Proposal #	Proposal Title	Discipline	Exp. #	Days Used
Carlos Garcia (S)	PI	Clemson University	Chemistry	Supported by NHMFL users services via its core grant			P14950	Modified alumina catalysts with organic groups for fructose dehydration process into a continuous reactor to obtain 5-hydroxymethylfurfural	Chemistry, Geochemistry	3	15
Leah Casabianca (S)	C	Clemson University	Chemistry	Consejo Nacional de Ciencia y Tecnologia (CONACyT)							
Rivera de la Rosa (S)	C	Autonomo of Nuevo León	Chemical Engineering								
Sungsool Wi (S)	C	NHMFL	NMR								
Lucy Ngatia (S)	PI	Florida Agricultural and Mechanical University	Center of Water and Air Quality	USDA		16-CA-11330140-046	P14938	Influence of land use, cover, and historical management practices on organic matter in the Apalachicola National Forest	Chemistry, Geochemistry	1	7
Gmebisola Akinbi (G)	C	FAMU	Center for Water Resources								
Johnny Grace (S)	C	U.S. Department of Agriculture	Forest service								
Yuch Ping Hsieh (S)	C	Florida Agricultural and Mechanical University	College of Agriculture and Food Sciences								
Odemari Mbuya (S)	C	Florida Agricultural and Mechanical University	College of Agriculture and Food Sciences								
Djanan Nemours (T)	C	Florida Agricultural and Mechanical University	College of Agriculture and Food Sciences								
Robert Taylor (S)	C	Florida Agricultural and Mechanical University	College of Agriculture and Food Sciences								
Sabyasachi Sen (S)	PI	University of California, Davis	Chemical Engineering and Materials Science	NSF - National Science Foundation	DMR – Division of Materials Research	DMR1505185					
Jackson Badger (G)	C	University of California, Davis	Chemistry								
Zhehong Gan (S)	C	NHMFL	NHMFL								
Ivan Hung (S)	C	NHMFL	CIMAR/NMR								
Kirill Kovnir (S)	C	University of California, Davis	Department of Chemistry								
Maxwell Marple (G)	C	University of California, Davis	Chemical Engineering and Materials Science								
Zachary Whittles (U)	C	University of California, Davis	Dept. of Materials Science & Engineering								

# Appendix VI – User Proposals

Participants (Name, Role, Org., Dept.)		Funding Sources (Funding Agency, Division, Award #)			Proposal #	Proposal Title	Discipline	Exp. #	Days Used		
Harry Dorn (S)	PI	Virginia Polytechnic Institute and State University	Chemistry	No other support (i.e. this experiment is entirely supported by NHMFL users services via its core grant)		<b>P14889</b>	EPR studies on the effects of gadolinium-based fullerenes on DNP enhancements at cryogenic temperatures	Biology, Biochemistry, Biophysics	2	11	
Zhehong Gan (S)	C	NHMFL	NHMFL								
Stephen Hill (S)	C	NHMFL	EMR								
Ivan Hung (S)	C	NHMFL	CIMAR/NMR								
Johannes McKay (P)	C	Keysight Technologies	MMIC Microwave								
Frederic Mentink (S)	C	NHMFL	NMR Division								
Johan van Tol (S)	C	NHMFL	EMR								
Xiaoling Wang (P)	C	NHMFL	NMR								
Sophia Hayes (S)	PI	Washington University in St. Louis	Chemistry	NSF - National Science Foundation	CHE – Division of Chemistry	1102637	<b>P14872</b>	High field NMR study of the temperature dependent annealing process of solution deposited aluminum and gallium oxide thin films	Chemistry, Geochemistry	1	8
Yvonne Afriyie (G)	C	Washington University in St. Louis	Chemistry								
Robert Marti (G)	C	Washington University in St. Louis	Chemistry								
Daphna Shimon (P)	C	Washington University in St. Louis	Chemistry								
James Guest (S)	PI	University of Miami	The Miami Project to Cure Paralysis	ISRT International Spinal trust			<b>P14850</b>	Creation of new axonal pathways on non-human primate	Biology, Biochemistry, Biophysics	1	34
Francisco Benavides Jaramillo (G)	C	University of Miami	Miller School of Medicine								
Elizabeth Bradbury (S)	C	King's College London	The Wolfson Center for Age-Related Diseases								
Rafaela de Negri (S)	C	University of Miami	Miami Project to Cure Paralysis								
Abigail Flores (S)	C	University of Miami	The Miami Project to Cure Paralysis								
Samuel Grant (S)	C	NHMFL	Chemical & Biomedical Engineering								
Jens Rosenberg (S)	C	NHMFL	NMR								
Andrea Santamaria (P)	C	University of Miami	The Miami Project to Cure Paralysis								
Juan Solano (S)	C	University of Miami	Miller School of Medicine								
Joost Verhaagen (S)	C	Free University of Amsterdam	Molecular and Cellular								

# Appendix VI – User Proposals

Participants (Name, Role, Org., Dept.)			Funding Sources (Funding Agency, Division, Award #)			Proposal #	Proposal Title	Discipline	Exp. #	Days Used	
Leejoo Wi (G)	C	NHMFL	Neurobiology NMR								
Mandip Sachdeva (S)	PI	Florida Agricultural and Mechanical University	College of Pharmacy and Pharmaceutical Sciences	NIH - National Institutes of Health	NCI – National Cancer Institute	R21CA175618	<b>P14849</b>	Telemisartan loaded Gd-liposome for enhanced MRI detection in lung tumors	Biology, Biochemistry, Biophysics	1	9
Samuel Grant (S)	C	NHMFL	Chemical & Biomedical Engineering								
Ketan Patel (P)	C	Florida Agricultural and Mechanical University	Department of Pharmaceutics								
Jens Rosenberg (S)	C	NHMFL	NMR								
William Brey (S)	PI	NHMFL	NMR	NIH - National Institutes of Health	NIGMS – National Institute of General Medical Sciences	GM120151	<b>P14828</b>	Probe testing, development, maintenance, repairs	Magnets, Materials, Testing, Instrumentation	2	7
Ghoncheh Amouzandeh (G)	C	Florida State University (FSU)	Physics	NIH - National Institutes of Health	NIGMS – National Institute of General Medical Sciences	GM122698					
Rajendra Arora (S)	C	Florida Agricultural and Mechanical University	Electrical and Computer Engineering	NHMFL UCGP - User Collaboration Grants Program							
Art Edison (S)	C	University of Georgia	CCRC, Biochemistry and Genetics	Supported by NHMFL users services via its core grant							
Nicolas Freytag (S)	C	Bruker Biospin									
Jerris Hooker (P)	C	Florida Agricultural and Mechanical University	NMR								
Lawrence Hornak (S)	C	University of Georgia	School of Electrical and Computer Engineering								
Erik Olson (U)	C	Florida State University (FSU)	Electrical and Computer Engineering								
Vijay Ramaswamy (T)	C	Bruker Biospin									

# Appendix VI – User Proposals

	Participants (Name, Role, Org., Dept.)			Funding Sources (Funding Agency, Division, Award #)			Proposal #	Proposal Title	Discipline	Exp. #	Days Used
Riqiang Fu (S)	PI	NHMFL	NMR	No other support (i.e. this experiment is entirely supported by NHMFL users services via its core grant)			<b>P14807</b>	Investigation of Solid Electrolyte Interphase (SEI) Formation in Lithium Ion Batteries using Multinuclear Magnetic Resonance Spectroscopy	Chemistry, Geochemistry	11	51
Yong Yang (S)	C	Xiamen University	Department of Chemistry								
Guiming Zhong (G)	C	Xiamen University	Chemistry								
Zhehong Gan (S)	PI	NHMFL	NHMFL	NSERC of Canada			<b>P14747</b>	Quadrupolar nuclei NMR using 36 T Series Connected Hybrid Magnet	Chemistry, Geochemistry	18	100.5
Mark Bird (S)	C	NHMFL	MS&T	NIH - National Institutes of Health	NIAID – National Institute of Allergy and Infectious Diseases	Dr. Cross SRAD					
William Brey (S)	C	NHMFL	NMR	Supported by NHMFL users services via its core grant							
Eduard Chekmenev (S)	C	Vanderbilt University	Institute of Imaging Science								
Michael Colvin (P)	C	Massachusetts Institute of Technology	Chemistry								
Tim Cross (S)	C	NHMFL	NHMFL/Chemistry & Biochemistry								
Petr Gor'kov (S)	C	NHMFL	CIMAR								
Adrian Griffin (S)	C	Oxford NMR Ltd	Owner								
Robert Griffin (S)	C	Massachusetts Institute of Technology	Chemistry								
Ivan Hung (S)	C	NHMFL	CIMAR/NMR								
Eric Keeler (G)	C	Massachusetts Institute of Technology	Chemistry								
Ilya Litvak (S)	C	NHMFL	CIMAR/NMR								
Vladimir Michaelis (S)	C	University of Alberta	Chemistry								
Alexander Nevzorov (S)	C	North Carolina State University	Chemistry								
Joana Paulino (P)	C	NHMFL	CIMAR								
Jeffrey Schiano (S)	C	Pennsylvania State University	Electrical Engineering								

# Appendix VI – User Proposals

		Participants (Name, Role, Org., Dept.)		Funding Sources (Funding Agency, Division, Award #)			Proposal #	Proposal Title	Discipline	Exp. #	Days Used
Jiahui Shen (G)	C	Queen's University at Kingston	Chemistry								
Alex Smirnov (S)	C	North Carolina State University	Chemistry								
Jack Toth (S)	C	NHMFL	MS&T								
Xiaoling Wang (P)	C	NHMFL	NMR								
Gang Wu (S)	C	Queen's University at Kingston	Chemistry								
Douglas Kojetin (S)	PI	The Scripps Research Institute - Florida	Molecular Therapeutics	NIH - National Institutes of Health		R01DK101871	<b>P14736</b>	NMR analysis of ligand binding to the nuclear receptor PPAR $\gamma$ , a type 2 diabetes drug target	Biology, Biochemistry, Biophysics	1	7
Kendra Frederick (S)	PI	University of Texas, Southwestern	Biophysics	CPRIT			<b>P14735</b>	Protein conformation determined in native cellular environments	Biology, Biochemistry, Biophysics	2	11
Whitney Costello (G)	C	University of Texas Southwestern Medical Center	Biophysics	UTSouthwestern Endowed Scholar in Medical Research							
Frederic Mentink (S)	C	NHMFL	NMR Division	Lupe Murchinson Foundation							
Yiling Xiao (P)	C	University of Texas Southwestern Medical Center	Biophysics	Welsh Foundation							
Gang Wu (S)	PI	Queen's University at Kingston	Chemistry	NSERC of Canada			<b>P14705</b>	Heteronuclear $^{13}\text{C}\{^{17}\text{O}\}$ and $^1\text{H}\{^{17}\text{O}\}$ correlation spectroscopy for organic solids	Chemistry, Geochemistry	10	61
Zhehong Gan (S)	C	NHMFL	NHMFL								
Ivan Hung (S)	C	NHMFL	CIMAR/NMR								
Betty Lin (G)	C	Queen's University at Kingston	Chemistry								
Frederic Mentink (S)	C	NHMFL	NMR Division								
Xiaoling Wang (P)	C	NHMFL	NMR								
Tim Cross (S)	PI	NHMFL	NHMFL/Chemistry & Biochemistry	NIH - National Institutes of Health	NIAID – National Institute of Allergy and Infectious Diseases	A1074805-01	<b>P14693</b>	Structural Characterization of ChiZ membrane protein	Biology, Biochemistry, Biophysics	27	159
Cristian Escobar (P)	C	NHMFL	IMB	NIH - National Institutes of Health	NIAID – National Institute of Allergy and Infectious Diseases	A1119178					
Rongfu Zhang (P)	C	NHMFL	NHMFL								
Bradley Chmelka (S)	PI	University of California, Santa Barbara	Department of Chemical Engineering	NSF - National Science Foundation		CBET-1335694	<b>P13658</b>	Low-Gamma Quadrupolar Nuclei in Nanostructured Solids	Engineering	2	8



# Appendix VI – User Proposals

	Participants (Name, Role, Org., Dept.)		Funding Sources (Funding Agency, Division, Award #)			Proposal #	Proposal Title	Discipline	Exp. #	Days Used	
Lia Addadi (S)	C	Weizmann Institute of Science	Department of Structural Biology								
Yuval Golan (S)	C	Ben Gurion University of the Negev	Department of Materials Engineering								
Maria Iglesias-Rodriguez (P)	C	University of California, Santa Barbara	Ecology, Evolution and Marine Biology								
Paul Matson (P)	C	University of California, Santa Barbara	Ecology, Evolution and Marine Biology								
Nathan Prisco (G)	C	University of California, Santa Barbara	Chemical Engineering								
Rahul Sangodkar (G)	C	University of California, Santa Barbara	Chemical Engineering								
George Scherer (S)	C	Princeton University	Department of Civil and Environmental Engineering								
Ram Seshadri (S)	C	University of California, Santa Barbara	Materials								
James Weaver (S)	C	Harvard University	Wyss Institute								
Steve Weiner (S)	C	Weizmann Institute of Science	Department of Structural Biology								
Smita Mohanty (S)	PI	Oklahoma State University	Chemistry	No other support (i.e. this experiment is entirely supported by NHMFL users services via its core grant)		<b>P13616</b>	Structure & Function Studies of Proteins	Biology, Biochemistry, Biophysics	10	91	
Bharat Chaudhary (G)	C	Oklahoma State University	Department of Chemistry								
Courtney Dunn (U)	C	Oklahoma State University	Chemistry								
Suman Mazumder (P)	C	Oklahoma State University	Chemistry								
Mohiuddin Ovee (P)	C	Oklahoma State University	Department of Chemistry								
Tim Cross (S)	PI	NHMFL	NHMFL/Chemistry & Biochemistry	NIH - National Institutes of Health	NIAID – National Institute of Allergy and Infectious Diseases	AI119178	<b>P13604</b>	Structural Characterization of the Full Length CrgA protein from the Tuberculosis Cell	Biology, Biochemistry, Biophysics	30	183

# Appendix VI – User Proposals

	Participants (Name, Role, Org., Dept.)			Funding Sources (Funding Agency, Division, Award #)			Proposal #	Proposal Title	Discipline	Exp. #	Days Used
Huajun Qin (T)	C	Florida State University (FSU)	Chemistry & Biochemistry					Division Apparatus			
Malini Rajagopalan (S)	C	University of Texas Health Science Center at Tyler	Health and Science Center								
Yiseul Shin (G)	C	Florida State University (FSU)	Chemistry								
Joshua Taylor (U)	C	Florida State University (FSU)	Chemistry & Biochemistry								
Huan-Xiang Zhou (S)	C	University of Illinois at Chicago	Physics and Chemistry								
A. Dean Sherry (S)	PI	University of Texas, Southwestern	Advanced Imaging Research Center	NIH - National Institutes of Health	NCI – National Cancer Institute	CA115531-09	<b>P13596</b>	Localized 31P NMR spectroscopy and (1H) APT imaging studies of brain glioma at 21.1 T	Biology, Biochemistry, Biophysics	1	4
Cathy Levenson (S)	C	Florida State University (FSU)	Biomedical Sciences								
Jimin Ren (S)	C	University of Texas, Southwestern	Advanced Imaging Research Center								
Victor Schepkin (S)	C	NHMFL	CIMAR								
Masaya Takahashi (S)	C	University of Texas, Southwestern	Advanced Imaging Research Center								
Hubert Yin (S)	PI	University of Colorado, Boulder	Chemistry and Biochemistry	NIH - National Institutes of Health	NIGMS – National Institute of General Medical Sciences	GM103843, GM101279	<b>P11501</b>	Human Toll-like Receptors Structure Determination by solid state NMR Spectroscopy	Biology, Biochemistry, Biophysics	4	23
Tim Cross (S)	C	NHMFL	NHMFL/Chemistry & Biochemistry								
Nabanita Das (P)	C	University of Colorado, Boulder	BioFrontier								
Armando Jerome de Jesus (P)	C	University of Colorado, Boulder	Biochemistry								
Ivan Hung (S)	C	NHMFL	CIMAR/NMR								
Lucio Frydman (S)	PI	Weizmann Institute of Science	Dept. Chemical Physics	No other support (i.e. this experiment is entirely supported by NHMFL users services via its core grant)			<b>P11492</b>	EPR and NMR Spectroscopy of Small Molecules in Low Viscosity Solvents	Biology, Biochemistry, Biophysics	8	143
Adewale Akinfaderin (G)	C	Florida State University (FSU)	Physics								
Thierry Dubroca (P)	C	NHMFL	EMR								
Stephen Hill (S)	C	NHMFL	EMR								
Johannes McKay (P)	C	Keysight Technologies	MMIC Microwave								
Johan van Tol (S)	C	NHMFL	EMR								
Sungsool Wi (S)	C	NHMFL	NMR								

# Appendix VI – User Proposals

		Participants (Name, Role, Org., Dept.)		Funding Sources (Funding Agency, Division, Award #)			Proposal #	Proposal Title	Discipline	Exp. #	Days Used
Victor Schepkin (S)	PI	NHMFL	CIMAR	Friedrich Ebert Stiftung, Bonn, Germany			<b>P11487</b>	The development of the TQTPPI in vivo imaging of Na, K and Cl at 21.1 T using PV6 software	Biology, Biochemistry, Biophysics	2	7
Shannon Helsper (T)	C	NHMFL	NMR								
Andreas Neubauer (P)	C	Heidelberg University	Physics								
Lothar Schad (S)	C	Heidelberg University	Computer Assisted Clinical Medicine								
Gianluigi Veglia (S)	PI	University of Minnesota, Twin Cities	BMBB	NIH - National Institutes of Health	NHLBI – National Heart and Blood Institute	HL010647	<b>P11486</b>	NMR Structural Analysis of Sarcoplasmic Reticulum Proteins in Membranes	Biology, Biochemistry, Biophysics	1	10
Tata Gopinath (P)	C	University of Minnesota, Twin Cities	Biochemistry	American Heart Association	16PRE27770056						
Sarah Nelson (G)	C	University of Minnesota, Twin Cities	Biochemistry, Molecular Biology, and Biophysics								
Leonard Mueller (S)	PI	University of California, Riverside	Chemistry	NIH - National Institutes of Health	NIGMS – National Institute of General Medical Sciences	GM097569	<b>P11467</b>	Chemically-Rich Structure and Dynamics in the Active Site of Tryptophan Synthase	Biology, Biochemistry, Biophysics	7	48
Bethany Caulkins (G)	C	University of California, Riverside	Chemistry								
Micheal Dunn (S)	C	University of California, Riverside	Biochemistry								
Joanna Long (S)	C	University of Florida	Biochemistry & Molecular Biology								
Frederic Mentink (S)	C	NHMFL	NMR Division								
Gwladys Riviere (P)	C	University of Florida	Biochemistry and molecular biology								
Xiaoling Wang (P)	C	NHMFL	NMR								
Yan Li (S)	PI	Florida State University (FSU)	Chemical and Biomedical Engineering	NSF - National Science Foundation	BRIGE-1342192		<b>P11457</b>	MPIO Labeling of Cyogenically Preserved Neuroprogenitor Cells	Engineering	1	18
Samuel Grant (S)	C	NHMFL	Chemical & Biomedical Engineering								
Jens Rosenberg (S)	C	NHMFL	NMR								
Yuanwei Yan (G)	C	Florida State University (FSU)	Chemical and Biomedical Engineering								
Samuel Grant (S)	PI	NHMFL	Chemical & Biomedical Engineering	American Heart Association			<b>P11442</b>	In vivo tracking of exogenous and labeled cell therapy to	Biology, Biochemistry, Biophysics	3	31

# Appendix VI – User Proposals

	Participants (Name, Role, Org., Dept.)			Funding Sources (Funding Agency, Division, Award #)			Proposal #	Proposal Title	Discipline	Exp. #	Days Used
Nastaren Abad (G)	C	Florida State University (FSU)	Chemical-Biomedical Engineering Physics	NHMFL UCGP - User Collaboration Grants Program				treat stroke: Cell migration & 23Na MRI			
Ghoncheh Amouzandeh (G)	C	Florida State University (FSU)		NIH - National Institutes of Health	NINDS - National Institute of Neurological Disorders and Stroke	NS102395					
Frederick Bagdasarian (G)	C	Florida State University (FSU)	College of Engineering	NHMFL VSP - Visiting Scientist Program							
Shannon Helsper (T)	C	NHMFL	NMR	Israel Science Foundation							
Teng Ma (S)	C	Florida State University (FSU)	Chemistry & Biomedical Engineering	Martin Kimmel Institute of Magnetic Resonance							
Abdol Aziz Ould Ismail (T)	C	University of Pennsylvania	Department of Radiology	Perlman Family Foundation							
Jens Rosenberg (S)	C	NHMFL	NMR								
Tangi Roussel (P)	C	Alternative Energies and Atomic Energy Commission	NeuroSpin								
Leejoo Wi (G)	C	NHMFL	NMR								
Xuegang Yuan (G)	C	Florida State University (FSU)	Chemical & Biomedical Engineering								
Kevin Huang (S)	PI	University of South Carolina	College of Engineering and Computing	FSU			<b>P09504</b>	High-temperature Solid-state NMR Studies of Ionic Conduction Mechanisms in Low-cost and Rare-earth-free Superior Fast Oxide-ion Conductor Sr3-3xNa3xSi3O9-1.5x	Chemistry, Geochemistry	27	304
Candace Chan (S)	C	Arizona State University	Materials Science & Engineering	NSF - National Science Foundation	DMR – Division of Materials Research	DMR1553519					
Hailong Chen (S)	C	Georgia Institute of Technology	School of Mechanical Engineering	NSF - National Science Foundation	CBET - Chemical, Bioengineering, Environmental, and Transport Systems	CBET1340269					
Po-Hsiu Chien (G)	C	Florida State University (FSU)	Chemistry and Biochemistry	NSF - National Science Foundation	DMR – Division of Materials Research	DMR1508404					
Xuyong Feng (P)	C	Florida State University (FSU)	Chemistry and Biochemistry	American Association for the Advancement of Science					Marion Milligan Mason Award		
Zhenxing Feng (S)	C	Oregon State University	School of Chemical, Biological, and								

# Appendix VI – User Proposals

Participants (Name, Role, Org., Dept.)			Funding Sources (Funding Agency, Division, Award #)		Proposal #	Proposal Title	Discipline	Exp. #	Days Used	
Kevin Huang (S)	C	University of South Carolina	Environmental Engineering College of Engineering and Computing							
Xiang Li (G)	C	Florida State University (FSU)	Chemistry and Biochemistry							
Alyssa Rose (G)	C	Florida State University (FSU)	Chemistry							
Likai Song (S)	C	NHMFL	EMR							
Mingxue Tang (P)	C	Florida State University (FSU)	Chemistry & Biochemistry							
Jin Zheng (G)	C	Florida State University (FSU)	Chemistry & Biochemistry							
Tim Cross (S)	PI	NHMFL	NHMFL/Chemistry & Biochemistry	NHMFL	PI SRAD	<b>P08486</b>	Dynamics of M2 full length: Understanding the dynamics of the proton conductance and the gating mechanism of the full length M2 proton channel of Influenza A.	Biology, Biochemistry, Biophysics	9	51
Gabriela Campos de Araujo (G)	C	UNESP	Chemistry Department	NHMFL						
Riqiang Fu (S)	C	NHMFL	NMR	FSU						
Ivan Hung (S)	C	NHMFL	CIMAR/NMR							
Joana Paulino (P)	C	NHMFL	CIMAR							
Huajun Qin (T)	C	Florida State University (FSU)	Chemistry & Biochemistry							
Sungsool Wi (S)	C	NHMFL	NMR							
James Guest (S)	PI	University of Miami	The Miami Project to Cure Paralysis	The State of Florida		<b>P08462</b>	Locomotor recovery threshold and Immune response associated to autologous Schwann cell transplants intended for remyelination strategies after spinal cord injury (SCI).	Biology, Biochemistry, Biophysics	1	12
Francisco Benavides Jaramillo (G)	C	University of Miami	Miller School of Medicine	NHMFL UCGP - User Collaboration Grants Program						
Elizabeth Bradbury (S)	C	King's College London	The Wolfson Center for Age-Related Diseases	The Miami Project to Cure Paralysis Clinical Trials Initiative						
William Brey (S)	C	NHMFL	NMR							
Rafaela de Negri (S)	C	University of Miami	Miami Project to Cure Paralysis							
Abigail Flores (S)	C	University of Miami	The Miami Project to Cure Paralysis							
Samuel Grant (S)	C	NHMFL	Chemical & Biomedical Engineering							
Jens Rosenberg (S)	C	NHMFL	NMR							
Andrea Santamaria (P)	C	University of Miami	The Miami Project to Cure Paralysis							
Juan Solano (S)	C	University of Miami	Miller School of Medicine							

# Appendix VI – User Proposals

Participants (Name, Role, Org., Dept.)		Funding Sources (Funding Agency, Division, Award #)			Proposal #	Proposal Title	Discipline	Exp. #	Days Used	
Joost Verhaagen (S)	C	Free University of Amsterdam	Molecular and Cellular Neurobiology							
Zhehong Gan (S)	PI	NHMFL	NHMFL	No other support (i.e. this experiment is entirely supported by NHMFL users services via its core grant)	<b>P08461</b>	Development and applications of high-field solid-state NMR methods	Magnets, Materials, Testing, Instrumentation	2	17	
Ivan Hung (S)	C	NHMFL	CIMAR/NMR							
Hans Jakobsen (S)	C	Aarh	Department of Chemistry							
Kirill Kovnir (S)	C	University of California, Davis	Department of Chemistry							
Conggang Li (S)	C	Wuhan Institute of Physics & Mathematics, Chinese Academy of Sciences	State Key Lab of Magnetic Resonance							
Maxwell Marple (G)	C	University of California, Davis	Chemical Engineering and Materials Science							
Tatyana Polenova (S)	C	University of Delaware	Department of Chemistry							
Sabyasachi Sen (S)	C	University of California, Davis	Chemical Engineering and Materials Science							
Gang Wu (S)	C	Queen's University at Kingston	Chemistry							
Chang Ryu (S)	PI	Rensselaer Polytechnic Institute	Department of Chemistry & Chemical Biology	No other support (i.e. this experiment is entirely supported by NHMFL users services via its core grant)	<b>P08441</b>	Investigation of the network structure of sustainable epoxy materials from vegetable oils	Chemistry, Geochemistry	1	3	
Sungsool Wi (S)	C	NHMFL	NMR							
Zheqin Yang (P)	C	Rensselaer Polytechnic Institute	Chemistry							
Chulsung Bae (S)	PI	Rensselaer Polytechnic Institute	Department of Chemistry & Chemical Biology	NSF - National Science Foundation	747667	<b>P08440</b>	Study of Water Dynamics in Superacidic Hydrocarbon Proton Exchange Membranes Using Solid-State and Pulsed-Field Gradient NMR Spectroscopy	Chemistry, Geochemistry	3	18
Sungsool Wi (S)	C	NHMFL	NMR	Supported by NHMFL users services via its core grant						
Liliya Vugmeyster	PI	University of	Chemistry	NIH - National Institutes	NIGMS – GM111681-02	<b>P08439</b>	Dynamics of amyloid	Biology,	2	14

# Appendix VI – User Proposals

(S)	Participants (Name, Role, Org., Dept.)		Funding Sources (Funding Agency, Division, Award #)			Proposal #	Proposal Title	Discipline	Exp. #	Days Used	
		Colorado, Denver		of Health			Abeta peptide by deuterium NMR	Biochemistry, Biophysics			
Isaac Falconer (U)	C	University of Colorado, Denver	Chemistry	NIH - National Institutes of Health		National Institute of General Medical Sciences NIGMS – National Institute of General Medical Sciences GM111681					
Dmitry Ostrovsky (S)	C	University of Alaska, Anchorage	Mathematics								
Kwang Hun Lim (S)	PI	East Carolina University	Chemistry	NIH - National Institutes of Health	NS084138	<b>P08372</b>	Mechanistic studies of transthyretin misfolding and amyloid formation using solid-state NMR	Biology, Biochemistry, Biophysics	1	7	
Anvesh Kumar Reddy Dasari (G)	C	East Carolina University	Chemistry								
Zhehong Gan (S)	C	NHMFL	NHMFL								
Ivan Hung (S)	C	NHMFL	CIMAR/NMR								
Edward Agyare (S)	PI	Florida Agricultural and Mechanical University	Pharmaceutics	NIH - National Institutes of Health	U54MD008149	<b>P08365</b>	Thermosensitive Liposomal Loaded-gold Nanoparticles as Radiosensitizers for Pancreatic Cancer Therapy.	Biology, Biochemistry, Biophysics	1	10	
Kevin Affram (G)	C	Florida Agricultural and Mechanical University	College of Pharmacy and Pharmaceutical Sciences	NIH - National Institutes of Health	5G12MD0075832-32						
Samuel Grant (S)	C	NHMFL	Chemical & Biomedical Engineering	NIH - National Institutes of Health		NCI – National Cancer Institute 1P20CA1929990-02					
Sunil Krishnan (S)	C	University of Texas, MD Anderson Cancer Center	Radiation Oncology								
Jens Rosenberg (S)	C	NHMFL	NMR								
Tim Cross (S)	PI	NHMFL	NHMFL/Chemistry & Biochemistry	NIH - National Institutes of Health	NIAID – National Institute of Allergy and Infectious Diseases NIAID – National Institute of Allergy and Infectious Diseases AI010748	P01AI074805	<b>P08362</b>	Structure Determination of LspA, an M. Tuberculosis Transmembrane Protein	Biology, Biochemistry, Biophysics	5	73
Victoria Mooney (P)	C	Vertex Pharmaceuticals Inc	Biophysical chemistry	NIH - National Institutes of Health							
Huajun Qin (T)	C	Florida State University (FSU)	Chemistry & Biochemistry	NIH - National Institutes of Health	NIAID – National Institute of Allergy and Infectious Diseases AI119178						

# Appendix VI – User Proposals

	Participants		Funding Sources				Proposal #	Proposal Title	Discipline	Exp. #	Days Used
	(Name, Role, Org., Dept.)		(Funding Agency, Division, Award #)								
Zhehong Gan (S)	PI	NHMFL	NHMFL	No other support (i.e. this experiment is entirely supported by NHMFL users services via its core grant)			<b>P08360</b>	development, testing, maintenance & repairs	Magnets, Materials, Testing, Instrumentation	7	73.5
Ashley Blue (T)	C	NHMFL	NHMFL								
Ernesto Bosque (P)	C	NHMFL	ASC								
William Brey (S)	C	NHMFL	NMR								
Peng Chen (G)	C	GE Healthcare									
Daniel Davis (G)	C	NHMFL	ASC								
Rolf Hensel (S)	C	Bruker Biospin AG	NMR								
David Hilton (S)	C	NHMFL	Magnet Science & Technology								
Ivan Hung (S)	C	NHMFL	CIMAR/NMR								
Youngjae Kim (S)	C	NHMFL	ASC								
Jason Kitchen (T)	C	NHMFL	NMR								
David Larbalestier (S)	C	NHMFL	ASC								
Pietro Lendi (S)	C	Bruker BioSpin AG	NMR								
Ilya Litvak (S)	C	NHMFL	CIMAR/NMR								
Denis Markiewicz (S)	C	NHMFL	MS&T								
Frederic Mentink (S)	C	NHMFL	NMR Division								
George Miller (S)	C	NHMFL	MS&T								
Bernie O'Hare (T)	C	Bruker Biospin	Biospin								
Joana Paulino (P)	C	NHMFL	CIMAR								
Jeffrey Schiano (S)	C	Pennsylvania State University	Electrical Engineering								
Arthur Schwilch (S)	C	Bruker BioSpin AG	NMR								
Brian Thomson (G)	C	Pennsylvania State University	Electrical Engineering								
Ulf Trociewitz (S)	C	NHMFL	ASC								
Xiaoling Wang (P)	C	NHMFL	NMR								
Hubertus Weijers (S)	C	NHMFL	MS&T								
Tim Cross (S)	PI	NHMFL	NHMFL/Chemistry & Biochemistry	NIH - National Institutes of Health	NIAID – National Institute of Allergy and Infectious Diseases	227000-520-015450	<b>P08302</b>	Structure Study of the Full-length M2 Proton Channel in Membrane Bilayers	Biology, Biochemistry, Biophysics	3	27
Nabanita Das (P)	C	University of Colorado, Boulder	BioFrontier	NIH - National Institutes of Health	NIAID – National Institute of Allergy and Infectious	R01AI119178					



# Appendix VI – User Proposals

Participants (Name, Role, Org., Dept.)				Funding Sources (Funding Agency, Division, Award #)			Proposal #	Proposal Title	Discipline	Exp. #	Days Used
				Diseases							
E. Vindana Ekanayake (P)	C	Sanford Burnham Prebys Medical Discovery Institute	n/a								
Riqiang Fu (S)	C	NHMFL	NMR								
Yimin Miao (G)	C	CUNY Graduate Center	Chemistry								
Huajun Qin (T)	C	Florida State University (FSU)	Chemistry & Biochemistry								
Malini Rajagopalan (S)	C	University of Texas Health Science Center at Tyler	Health and Science Center								
Huan-Xiang Zhou (S)	C	University of Illinois at Chicago	Physics and Chemistry								
Riqiang Fu (S)	PI	NHMFL	NMR	NIH - National Institutes of Health	NIAID – National Institute of Allergy and Infectious Diseases	AI230007	<b>P07270</b>	Designing Solid State MAS NMR experiments to Differentiate Histidine Tautomeric States	Biology, Biochemistry, Biophysics	2	15
Tim Cross (S)	C	NHMFL	NHMFL/Chemistry & Biochemistry	National Key Basic Research Program of China		2014CB848700					
Jiangyu Cui (G)	C	University of Science and Technology of China	Physics	The National Science Fund for Distinguished Young Scholars							
Jun Li (P)	C	Beijing Computational Science Research Center	Physics	National Natural Science Foundation of China		11375167					
Yimin Miao (G)	C	CUNY Graduate Center	Chemistry	National Natural Science Foundation of China		11227901					
Xinhua Peng (S)	C	University of Science and Technology of China	Physics	Chinese Academy of Sciences		QYZDY-SSW-SLH004					
Fang Tian (S)	PI	Pennsylvania State University	Biochemistry and Molecular Biology, Penn State Medical School	NIH - National Institutes of Health	NIGMS – National Institute of General Medical Sciences	GM1059630-02	<b>P02428</b>	Spherical Nanoparticle Supported Lipid Bilayers for the Study of Membrane Architecture	Biology, Biochemistry, Biophysics	2	14
Xiaoyan Ding (P)	C	Pennsylvania State University	Biochemistry and Molecular Biology								
Riqiang Fu (S)	C	NHMFL	NMR								
Myriam Cotten (S)	PI	College of William and Mary	Applied Science	NSF - National Science Foundation	CHE – Division of Chemistry	832571	<b>P02289</b>	Membrane Interaction and	Biology, Biochemistry,	2	7

# Appendix VI – User Proposals

Participants (Name, Role, Org., Dept.)		Funding Sources (Funding Agency, Division, Award #)		Proposal #	Proposal Title	Discipline	Exp. #	Days Used
Riqiang Fu (S)	C	NHMFL	NMR		Atomic-Level Structures of Membrane-Active Peptides by 15N and 2H Solid-State NMR	Biophysics		
<b>Total Proposals:</b>							<b>Experiments:</b>	<b>Days:</b>
93							470	3,417.00

\* = A new PI for the reporting year.

PI = Principal Investigator; C = Collaborator

S = Senior Personnel; P = Postdoc; G = Graduate Student; U = Undergraduate Student; T = Technician, programmer

# Appendix VI – User Proposals

Participants (Name, Role, Org., Dept.)		Funding Sources (Funding Agency, Division, Award #)			Proposal #	Proposal Title	Discipline	Exp. #	Days Used		
Scott Crooker (S)	PI	National High Magnetic Field Laboratory (NHMFL)	Nat High Magnetic Field Lab	DOE - Department of Energy	LDRD – Laboratory Directed R&D		<b>P17437</b>	Magneto-optical spectroscopy of cesium-lead-halide perovskite nanocrystals to 65T	Condensed Matter Physics	1	9
Mateusz Goryca (P)	C	NHMFL	NHMFL								
Victor Klimov (S)	C	Los Alamos National Laboratory	C-PCS								
Kirk Post (P)	C	NHMFL	NHMFL								
Istvan Robel (S)	C	Los Alamos National Laboratory	C-PCS								
Sara Haravifard (S)	PI *	Duke University	Department of Physics	Duke University			<b>P17377</b>	New Plateaus in the Doped Spin Dimer System SrCu(2-x)Mgx(BO3)2 at High Fields	Condensed Matter Physics	1	5
Marcelo Jaime (S)	C	National High Magnetic Field Laboratory (NHMFL)	Physics								
Brodie Popovic (G)	C	Duke University	Physics								
Zhenzhong Shi (P)	C	National High Magnetic Field Laboratory (NHMFL)	CMS, NHMFL								
Xiaxin Ding (P)	PI *	National High Magnetic Field Laboratory (NHMFL)	NHMFL	NSF - National Science Foundation	DMR – Division of Materials Research	1157490	<b>P17375</b>	Development of the new technique for the magnetostriction measurement in pulsed magnetic fields	Magnets, Materials, Testing, Instrumentation	1	20
Yisheng Chai (S)	C	Chongqing University	Department of Applied Physics								
Sang Wook Cheong (S)	C	Rutgers University, New Brunswick	Physics and Astronomy								
Marcelo Jaime (S)	C	National High Magnetic Field Laboratory (NHMFL)	Physics								
Young Sun (S)	C	Institute of Physics, Chinese Academy of Sciences	Institute of Physics								
Vivien Zapf (S)	C	National High Magnetic Field Laboratory (NHMFL)	Physics								

# Appendix VI – User Proposals

Pablo Esquinazi (S)	PI *	Leipzig University	Superconductivity and Magnetism	DAAD - Deutscher Akademischer Austauschdienst			<b>P17374</b>	HIGH-FIELD BEHAVIOR OF THE INTERNAL INTERFACES OF GRAPHITE	Condensed Matter Physics	1	5
José Barzola-Quiquia (P)	C	Leipzig University	Superconductivity and Magnetism								
Marcelo Jaime (S)	C	National High Magnetic Field Laboratory (NHMFL)	Physics								
Christian Precker (G)	C	Leipzig University	Superconductivity and Magnetism								
Brian Maple (S)	PI	University of California, San Diego	Inst for Pure & Applied Physical Sciences	DOE - Department of Energy	Office of Science - BES – Basic Energy Sciences	DE-FG02-04ER46105	<b>P17341</b>	Physical properties of the URu <sub>2</sub> Si <sub>2</sub> system with chemical substitution in high magnetic fields	Condensed Matter Physics	2	10
Ryan Baumbach (S)	C	National High Magnetic Field Laboratory (NHMFL)	Physics	DOE - Department of Energy	NNSA – National Nuclear Security Administration	DE-NA0002909					
Alexander Breindel (G)	C	University of California, San Diego	Physics								
Marcelo Jaime (S)	C	National High Magnetic Field Laboratory (NHMFL)	Physics								
Trevor Keiber (P)	C	University of California, San Diego	Physics								
Sheng Ran (P)	C	University of California, San Diego	Physics								
John Singleton (S)	C	National High Magnetic Field Laboratory (NHMFL)	Physics								
David Reagor (S)	PI *	Los Alamos National Laboratory	Mail Stop T004	DOE - Department of Energy	NNSA – National Nuclear Security Administration		<b>P17327</b>	Development of Thermometry for the Fast Pulse Magnet	Magnets, Materials, Testing, Instrumentation	1	4
Jason Lashley (S)	C	Los Alamos National Laboratory	MST-NHMFL								
Charles Mielke (S)	C	National High Magnetic Field Laboratory (NHMFL)	Physics								
Zhiqiang Mao (S)	PI	Tulane University	Physics Department	DOE - Department of Energy	Office of Science - BES – Basic Energy Sciences	DE-SC0012432	<b>P16316</b>	Studies of exotic quantum phenomena near the	Condensed Matter Physics	1	22

# Appendix VI – User Proposals

Fedor Balakirev (S)	C	National High Magnetic Field Laboratory (NHMFL)	PFF					quantum limit in Dirac semimetals AMnSb2 (A=Sr, Ba and Yb)			
Marcelo Jaime (S)	C	National High Magnetic Field Laboratory (NHMFL)	Physics								
Jinyu Liu (G)	C	Tulane University	Department of Physics and Engineering Physics								
Ross McDonald (S)	C	National High Magnetic Field Laboratory (NHMFL)	Physics								
Masashi Miura (S)	PI *	Seikei University	Graduate School of Science and Technology MPA-CMMS	DOE - Department of Energy	Office of Science - BES – Basic Energy Sciences	LANLE8L5	<b>P16306</b>	V-I curves in pulsed fields to study vortex matter	Condensed Matter Physics	1	5
Maxime Leroux (P)	C	Los Alamos National Laboratory	MPA-STC								
Boris Maiorov (S)	C	Los Alamos National Laboratory	MPA-STC								
Grace Morgan (S)	PI *	University College Dublin	School of Chemistry and Chemical Biology NHMFL-PFF	MPA-CMMS			<b>P16285</b>	Multiferroic behavior at spin-state transitions – beyond Mn(taa)	Condensed Matter Physics	2	24
Shalinee Chikara (P)	C	National High Magnetic Field Laboratory (NHMFL)		Supported by NHMFL users services via its core grant							
Xiaxin Ding (P)	C	National High Magnetic Field Laboratory (NHMFL)	NHMFL								
Vibe Jakobsen (G)	C	University College Dublin	School of Chemistry								
Irina Kuehne (P)	C	University College Dublin	School of Chemistry								
John Singleton (S)	C	National High Magnetic Field Laboratory (NHMFL)	Physics								
Vivien Zapf (S)	C	National High Magnetic Field Laboratory (NHMFL)	Physics								
James Analytis (S)	PI	University of California, Berkeley	Physics	Gordon and Betty Moore Foundation EPIQS Initiative			<b>P16275</b>	Surface States in Weyl and Dirac Semimetals	Condensed Matter Physics	1	5

# Appendix VI – User Proposals

Nityan Nair (G)	C	University of California, Berkeley	Physics									
Brad Ramshaw (S)	PI	Cornell University	Laboratory of Atomic and Solid State Physics	Cornell University				<b>P16274</b>	Broken Symmetry in the High Field State of CeRhIn5	Biology, Biochemistry, Biophysics	1	5
Eric Bauer (S)	C	Los Alamos National Laboratory	MST-10									
Ross McDonald (S)	C	National High Magnetic Field Laboratory (NHMFL)	Physics									
Philip Moll (S)	C	ETH Zürich	MPI Chemical Physics of Solids									
Filip Ronning (S)	C	Los Alamos National Laboratory	MPA-CMMS									
Paul Goddard (S)	PI	University of Warwick	Department of Physics	European Research Council				<b>P16268</b>	Fermi surface investigations of a pyrochlore iridate close to a quantum critical point	Condensed Matter Physics	1	12
Kathrin Gotze (P)	C	University of Warwick	Department of Physics, Superconductivity and Magnetism group									
John Singleton (S)	C	National High Magnetic Field Laboratory (NHMFL)	Physics									
Pei-Chun Ho (S)	PI	California State University, Fresno	Physics	NSF - National Science Foundation	DMR – Division of Materials Research	1506677		<b>P16266</b>	Clarification of the High-Temperature and High Field Side of Phase Boundary of the Valance Transition in CeOs <sub>4</sub> Sb <sub>12</sub> , and Fermi-Surface Topologies of SmOs <sub>4</sub> Sb <sub>12</sub>	Condensed Matter Physics	1	5
Marcelo Jaime (S)	C	National High Magnetic Field Laboratory (NHMFL)	Physics									
Brian Maple (S)	C	University of California, San Diego	Inst for Pure & Applied Physical Sciences									
John Singleton (S)	C	National High Magnetic Field Laboratory (NHMFL)	Physics									
Antonio Vecchione (S)	PI	* CNR Institute SPIN	Physics	University of Salerno				<b>P16262</b>	Using high pulsed magnetic fields to manipulate Ru <sup>4+</sup> ground state properties in Sr <sub>4</sub> Ru <sub>3</sub> O <sub>10</sub>	Condensed Matter Physics	1	10
Marcelo Jaime (S)	C	National High Magnetic Field Laboratory (NHMFL)	Physics									
Dagmar Weickert (S)	C	National High Magnetic Field Laboratory	MPA-Mag									

# Appendix VI – User Proposals

Sang Wook Cheong (S)	PI	(NHMFL) Rutgers University, New Brunswick	Physics and Astronomy	Rutgers University			<b>P16261</b>	Magnetic frustration in hexagonal indates	Condensed Matter Physics	1	5
Jae Wook Kim (P)	C	Rutgers University, New Brunswick	Physics and Astronomy								
Vivien Zapf (S)	C	National High Magnetic Field Laboratory (NHMFL)	Physics								
Joseph Checkelsky (S)	PI *	Massachusetts Institute of Technology	Physics	Massachusetts Institute of Technology			<b>P16258</b>	High Field Studies of Magnetic Weyl Semimetals	Condensed Matter Physics	1	19
Aravind Devarakonda (G)	C	Massachusetts Institute of Technology	Physics								
Takehito Suzuki (P)	C	Massachusetts Institute of Technology	Department of Physics								
Linda Ye (G)	C	Massachusetts Institute of Technology	Physics								
Janice Musfeldt (S)	PI	University of Tennessee, Knoxville	Department of Chemistry	NSF - National Science Foundation	DMR – Division of Materials Research	1629079	<b>P16137</b>	High field spectroscopy of materials	Chemistry, Geochemistry	1	5
Ken O'Neal (G)	C	University of Tennessee, Knoxville	Chemistry								
Michael Yokosuk (G)	C	University of Tennessee, Knoxville	Chemistry								
Richard Schaller (S)	PI	Argonne National Laboratory	Center for Nanoscale Materials	NSF - National Science Foundation	DMR – Division of Materials Research	1629383	<b>P16100</b>	Exciton Size in 2- Dimensional Semiconductor Nanoplatelets	Condensed Matter Physics	2	10
Alexandra Brumberg (G)	C	Northwestern University	Chemistry								
Scott Crooker (S)	C	National High Magnetic Field Laboratory (NHMFL)	Nat High Magnetic Field Lab								
Benjamin Diroll (P)	C	Argonne National Laboratory	Nanoscience and Technology								
Samantha Harvey (G)	C	Northwestern University	Chemistry								
Brad Ramshaw (S)	PI	Cornell University	Laboratory of Atomic and Solid State Physics	Cornell University			<b>P16083</b>	Ultrasonic exploration of the high-eld phase of TaAs	Condensed Matter Physics	1	5
Maja Bachmann (G)	C	Max Planck Institute for Chemical Physics of	Microstructured Quantum Mater								

# Appendix VI – User Proposals

Eric Bauer (S)	C	Solids Los Alamos National Laboratory	MST-10								
Ross McDonald (S)	C	National High Magnetic Field Laboratory (NHMFL)	Physics								
Kimberly Modic (G)	C	National High Magnetic Field Laboratory (NHMFL)	PFF								
Philip Moll (S)	C	ETH Zürich	MPI Chemical Physics of Solids								
Filip Ronning (S)	C	Los Alamos National Laboratory	MPA-CMMS								
Jamie Manson (S)	PI	Eastern Washington University	Chemistry and Biochemistry	NSF - National Science Foundation	DMR – Division of Materials Research	1306158	<b>P15991</b>	Structure-property relationships in spin-1 quantum magnets	Condensed Matter Physics	2	19
Jamie Brambleby (G)	C	University of Warwick	Physics								
Paul Goddard (S)	C	University of Warwick	Department of Physics								
John Singleton (S)	C	National High Magnetic Field Laboratory (NHMFL)	Physics								
Craig Topping (G)	C	National High Magnetic Field Laboratory (NHMFL)	MPA-CMMS								
Silke Buehler-Paschen (S)	PI *	Technical University of Wien	Institute of Solid State Physics	FWF Austrian Science Fund			<b>P15985</b>	Electronic, magnetic, and topological properties of the Kondo insulator CeRu <sub>4</sub> Sn <sub>6</sub> from torque magnetometry and magnetoresistance	Condensed Matter Physics	4	20
Luis Balicas (S)	C	National High Magnetic Field Laboratory (NHMFL)	Condensed Matter Experiment								
Marcelo Jaime (S)	C	National High Magnetic Field Laboratory (NHMFL)	Physics								
Ross McDonald (S)	C	National High Magnetic Field Laboratory (NHMFL)	Physics								
Qimiao Si (S)	C	Rice University	Physics and Astronomy								



# Appendix VI – User Proposals

Dagmar Weickert (S)	C	National High Magnetic Field Laboratory (NHMFL)	MPA-Mag								
Diego Zocco (P)	C	Technical University of Wien	Institute of Solid State Physics								
Jeehoon Kim (S)	PI *	Pohang University of Science and Technology	Physics	Institute for Basic Science (IBS)		IBS-R014- D1	<b>P14985</b>	Electromagnetic response in the Weyl metal state	Condensed Matter Physics	2	11
Geunyoung Kim (G)	C	Pohang University of Science and Technology	Physics								
Heon-Jung Kim (S)	C	Daegu University	Physics								
Ki-Seok Kim (S)	C	Pohang University of Science and Technology	Physics								
Dongwoo Shin (G)	C	Pohang University of Science and Technology	Physics								
Dagmar Weickert (S)	C	National High Magnetic Field Laboratory (NHMFL)	MPA-Mag								
Jinho Yang (G)	C	Pohang University of Science and Technology	Physics								
Jin Hu (S)	PI *	Tulane University	Physics	DOE - Department of Energy	Office of Science - BES – Basic Energy Sciences	DE-SC0014208	<b>P14984</b>	Exotic High Field Quantum Phenomena of Nodal-line Fermions	Condensed Matter Physics	1	6
David Graf (S)	C	National High Magnetic Field Laboratory (NHMFL)	DC Field CMS								
Marcelo Jaime (S)	C	National High Magnetic Field Laboratory (NHMFL)	Physics								
Jinyu Liu (G)	C	Tulane University	Department of Physics and Engineering Physics								
Xue Liu (G)	C	Tulane University	Physics and Engineering Physics								
Zhiqiang Mao (S)	C	Tulane University	Physics Department								
Dagmar Weickert (S)	C	National High Magnetic Field Laboratory (NHMFL)	MPA-Mag								

# Appendix VI – User Proposals

Chunlei Yue (G)	C	Tulane University	Physics and Engineering Physics								
Yanglin Zhu (G)	C	Tulane University	Department of Physics and Engineering Physics								
Maria Señaris-Rodríguez (S)	PI *	University of Coruna	Dundamental Chemistry	Xunta de Galicia			<b>P14979</b>	New multisensitive materials based on the organic-inorganic hybrid perovskites [TPrA][M(dca)3](M: Mn2+, Fe2+, Co2+ and Ni2+)	Condensed Matter Physics	1	5
Juan Bermúdez-García (G)	C	University of Coruna	Fundamental Chemistry								
Manuel Sanchez-Anduljar (S)	C	University of Coruna	Chemistry								
John Singleton (S)	C	National High Magnetic Field Laboratory (NHMFL)	Physics								
Vivien Zapf (S)	C	National High Magnetic Field Laboratory (NHMFL)	Physics								
Krzysztof Gofryk (S)	PI	Idaho National Laboratory	Fuel Performance & Design	DOE - Department of Energy	Office of Science - BES – Basic Energy Sciences	K. Gofryk's DOE Early Career Award	<b>P14907</b>	Magnetoelastic behavior in uranium antimonide (USb) probed by magnetostriction and magnetization at high magnetic fields.	Condensed Matter Physics	3	15
Neil Harrison (S)	C	National High Magnetic Field Laboratory (NHMFL)	Physics								
Marcelo Jaime (S)	C	National High Magnetic Field Laboratory (NHMFL)	Physics								
Jason Jeffries (S)	C	Lawrence Livermore National Laboratory	Physical and Life Sciences Directorate								
Keshav Shrestha (P)	C	Idaho National Laboratory	Fuel Design and Development								
Dagmar Weickert (S)	C	National High Magnetic Field Laboratory (NHMFL)	MPA-Mag								
James Analytis (S)	PI	University of California, Berkeley	Physics	No other support (i.e. this experiment is entirely supported by NHMFL users services via its core grant)			<b>P14906</b>	Magnetotransport Studies of the Strange Metal State in an Unconventional High-Temperature Superconductor	Condensed Matter Physics	1	12

# Appendix VI – User Proposals

Nicholas Breznay (P)	C	Lawrence Berkeley National Laboratory	Materials Science								
Mun Chan (P)	C	National High Magnetic Field Laboratory (NHMFL)	Pulsed field Facility								
Ian Hayes (G)	C	University of California, Berkeley	physics								
Ross McDonald (S)	C	National High Magnetic Field Laboratory (NHMFL)	Physics								
Brad Ramshaw (S)	C	Cornell University	Laboratory of Atomic and Solid State Physics								
Arkady Shehter (S)	PI	National High Magnetic Field Laboratory (NHMFL)	NHMFL, DC Field Facility	NSF - National Science Foundation	DMR – Division of Materials Research	DMR-1157490 and the State of Florida.	<b>P14902</b>	Bulk linear magnetoresistance in the quantum critical regime of La <sub>2-x</sub> Sr <sub>x</sub> CuO <sub>4</sub>	Condensed Matter Physics	3	36
Fedor Balakirev (S)	C	National High Magnetic Field Laboratory (NHMFL)	PFF								
Jonathan Betts (S)	C	National High Magnetic Field Laboratory (NHMFL)	NHMFL-PFF								
Greg Boebinger (S)	C	National High Magnetic Field Laboratory (NHMFL)	Directors Office								
Jose Galvis Echeverri (P)	C	National High Magnetic Field Laboratory (NHMFL)	CMS								
Paula Giraldo Gallo (P)	C	National High Magnetic Field Laboratory (NHMFL)	Physics								
David Graf (S)	C	National High Magnetic Field Laboratory (NHMFL)	DC Field CMS								
Xiujun Iian (G)	C	National High Magnetic Field Laboratory (NHMFL)	NHMFL								

# Appendix VI – User Proposals

Ross McDonald (S)	C	National High Magnetic Field Laboratory (NHMFL)	Physics								
Kimberly Modic (G)	C	National High Magnetic Field Laboratory (NHMFL)	PFF								
Philip Moll (S)	C	ETH Zürich	MPI Chemical Physics of Solids								
Brad Ramshaw (S)	C	Cornell University	Laboratory of Atomic and Solid State Physics								
Laurel Stritzinger (P)	C	National High Magnetic Field Laboratory (NHMFL)	Physics								
Kirstin Alberi (T)	PI	National Renewable Energy Laboratory	Materials Science	DOE - Department of Energy	Office of Science	DE-AC36-08GO28308	<b>P14891</b>	Magneto-Photoluminescence Measurements of Bi Clusters in GaAs1-xBix	Condensed Matter Physics	1	5
Scott Crooker (S)	C	National High Magnetic Field Laboratory (NHMFL)	Nat High Magnetic Field Lab								
Angelo Mascarenhas (S)	C	National Renewable Energy Laboratory	Materials Science								
Filip Ronning (S)	PI	Los Alamos National Laboratory	MPA-CMMS	DOE - Department of Energy	LDRD – Laboratory Directed R&D	XWFL	<b>P14771</b>	Topology and Strong Correlations in High Fields	Condensed Matter Physics	2	10
Eric Bauer (S)	C	Los Alamos National Laboratory	MST-10								
Mun Chan (P)	C	National High Magnetic Field Laboratory (NHMFL)	Pulsed field Facility								
Marcelo Jaime (S)	C	National High Magnetic Field Laboratory (NHMFL)	Physics								
Ross McDonald (S)	C	National High Magnetic Field Laboratory (NHMFL)	Physics								
Brad Ramshaw (S)	C	Cornell University	Laboratory of Atomic and Solid State Physics								
Priscilla Rosa (G)	C	University Estadual de Campinas	Instituto Gleb Wataghin								

# Appendix VI – User Proposals

Laurel Stritzinger (P)	C	National High Magnetic Field Laboratory (NHMFL)	Physics								
Paul Tobash (P)	C	National High Magnetic Field Laboratory (NHMFL)	MPA-cmms								
Vivien Zapf (S)	C	National High Magnetic Field Laboratory (NHMFL)	Physics								
Haidong Zhou (S)	PI	University of Tennessee, Knoxville	Physics and Astronomy	NSF - National Science Foundation	DMR – Division of Materials Research	1350002	<b>P14742</b>	High field magnetization measurements of a new triangular lattice magnet with possible orbital ordering transition	Condensed Matter Physics	2	18
Neil Harrison (S)	C	National High Magnetic Field Laboratory (NHMFL)	Physics								
Ryan Rawl (G)	C	University of Tennessee, Knoxville	Physics								
Ryan Sinclair (G)	C	University of Tennessee, Knoxville	Physics and Astronomy								
Vivien Zapf (S)	C	National High Magnetic Field Laboratory (NHMFL)	Physics								
N. Phuan Ong (S)	PI	Princeton University	Physics	DOD - Department of Defense	U.S. Army	ARO W911NF-12-1-0461	<b>P14732</b>	(Thermo-)electric transport in the n=0 Landau level of Weyl semimetals	Condensed Matter Physics	1	12
Tong Gao (G)	C	Princeton University	Physics	DOD - Department of Defense	U.S. Army	ARO W911NF-11-1-0379					
Sihang Liang (G)	C	Princeton University	Physics	Betty & Gordon Moore foundation							
Wudi Wang (G)	C	Princeton University	Physics								
Ryan Baumbach (S)	PI	National High Magnetic Field Laboratory (NHMFL)	CMS	DOE - Department of Energy	Office of Science - BES – Basic Energy Sciences	DE-FG-02-04ER46105	<b>P14728</b>	High magnetic fields and the puzzle of f-electron localization-itinerancy physics	Condensed Matter Physics	1	12
Alexander Breindel (G)	C	University of California, San Diego	Physics	NSF - National Science Foundation	DMR – Division of Materials Research	DMR1206553					
David Graf (S)	C	National High Magnetic Field Laboratory	DC Field CMS	NHMFL UCGP - User Collaboration Grants Program							

# Appendix VI – User Proposals

Marcelo Jaime (S)	C	(NHMFL) National High Magnetic Field Laboratory (NHMFL)	Physics								
Trevor Keiber (P)	C	University of California, San Diego	Physics								
Brian Maple (S)	C	University of California, San Diego	Inst for Pure & Applied Physical Sciences								
Ross McDonald (S)	C	National High Magnetic Field Laboratory (NHMFL)	Physics								
Sheng Ran (P)	C	University of California, San Diego	Physics								
Scott Riggs (S)	C	National High Magnetic Field Laboratory (NHMFL)	CMS								
Arkady Shehter (S)	C	National High Magnetic Field Laboratory (NHMFL)	NHMFL, DC Field Facility								
Laurel Stritzinger (P)	C	National High Magnetic Field Laboratory (NHMFL)	Physics								
Brian Maple (S)	PI	University of California, San Diego	Inst for Pure & Applied Physical Sciences	DOE - Department of Energy	Office of Science - BES – Basic Energy Sciences	DEFG02-04-ER46105	<b>P14714</b>	Electrical Resistivity, Magnetization and Specific Heat	Condensed Matter Physics	1	13
Alexander Breindel (G)	C	University of California, San Diego	Physics	DOE - Department of Energy	NNSA – National Nuclear Security Administration	DE-NA0002909		Measurements of PrT2Cd20 (T = Ni, Pd) at Low Temperatures in High Magnetic Fields			
Sheng Ran (P)	C	University of California, San Diego	Physics								
John Singleton (S)	C	National High Magnetic Field Laboratory (NHMFL)	Physics								
Vivien Zapf (S)	C	National High Magnetic Field Laboratory (NHMFL)	Physics								
Andrew Wildes (S)	PI	Institut Laue-Langevin	Science	Institut Laue-Langevin			<b>P13633</b>	High field magnetization in	Condensed Matter Physics	1	5

# Appendix VI – User Proposals

Diane Lançon (G)	C	Institut Laue-Langevin	Science					FePS3			
Henrik Ronnow (S)	C	Ecole Polytechnique Federale de Lausanne	LQM								
Nicholas Butch (S)	PI	National Institute of Standards and Technology	NIST Center for Neutron Research	Department of Commerce			<b>P13626</b>	High Field Studies of Electron-Doped Cuprate Thin Films	Condensed Matter Physics	1	5
Richard Greene (S)	C	University of Maryland, College Park	Physics								
Joshua Higgins (P)	C	University of Maryland, College Park	Physics								
Ross McDonald (S)	C	National High Magnetic Field Laboratory (NHMFL)	Physics								
Tarapada Sarkar (P)	C	University of Maryland, College Park	Physics								
Zhiqiang Mao (S)	PI	Tulane University	Physics Department	DOE - Department of Energy	Office of Science - BES – Basic Energy Sciences	DE-SC0012432	<b>P12574</b>	Studies of Quantum Oscillations in the Dirac semimetal SrMnSb <sub>2</sub> and Weyl semimetal TaP	Condensed Matter Physics	1	5
Fedor Balakirev (S)	C	National High Magnetic Field Laboratory (NHMFL)	PFF								
David Graf (S)	C	National High Magnetic Field Laboratory (NHMFL)	DC Field CMS								
Jin Hu (S)	C	Tulane University	Physics								
Marcelo Jaime (S)	C	National High Magnetic Field Laboratory (NHMFL)	Physics								
Jinyu Liu (G)	C	Tulane University	Department of Physics and Engineering Physics								
Zhiqiang Mao (S)	C	Tulane University	Physics Department								
Ross McDonald (S)	C	National High Magnetic Field Laboratory (NHMFL)	Physics								
Chunlei Yue (G)	C	Tulane University	Physics and Engineering Physics								

# Appendix VI – User Proposals

Yanglin Zhu (G)	C	Tulane University	Department of Physics and Engineering Physics								
Andreas Stier (P)	PI	National High Magnetic Field Laboratory (NHMFL)	MPA-CMMS	No other support (i.e. this experiment is entirely supported by NHMFL users services via its core grant)			<b>P12557</b>	Polarization sensitive photoluminescence and reflection spectroscopy of novel atomically thin materials in ultrahigh magnetic fields at the NHMFL.	Condensed Matter Physics	2	29
Mun Chan (P)	C	National High Magnetic Field Laboratory (NHMFL)	Pulsed field Facility								
Scott Crooker (S)	C	National High Magnetic Field Laboratory (NHMFL)	Nat High Magnetic Field Lab								
Nathan Wilson (G)	C	University of Washington	Physics								
Charles Agosta (S)	PI	Clark University	Department of Physics	Clark University			<b>P11532</b>	Inhomogeneous Superconductivity	Condensed Matter Physics	1	5
Logan Bishop-Van Horn (U)	C	Clark University	Physics								
John Schlueter (S)	C	Argonne National Laboratory	Materials Science								
Neil Harrison (S)	PI	National High Magnetic Field Laboratory (NHMFL)	Physics	DOE - Department of Energy	Office of Science - BES – Basic Energy Sciences	LANL F100	<b>P11510</b>	Electronic structure of URu <sub>2</sub> Si <sub>2</sub> and related strongly correlated materials in very strong magnetic fields	Condensed Matter Physics	2	18
Fedor Balakirev (S)	C	National High Magnetic Field Laboratory (NHMFL)	PFF	DOE - Department of Energy	Office of Science - BES – Basic Energy Sciences	LANLF100					
Mun Chan (P)	C	National High Magnetic Field Laboratory (NHMFL)	Pulsed field Facility								
Toni Helm (P)	C	Max Planck Institute	Physics of Quantum materials								
Ross McDonald (S)	C	National High Magnetic Field Laboratory (NHMFL)	Physics								
Philip Moll (S)	C	ETH Zürich	MPI Chemical Physics of Solids								
John Singleton (S)	C	National High Magnetic Field Laboratory	Physics								



# Appendix VI – User Proposals

Laurel Stritzinger (P)	C	(NHMFL) National High Magnetic Field Laboratory (NHMFL)	Physics								
Stefan Sullow (S)	PI	Technical University of Braunschweig	IPKM	No other support (i.e. this experiment is entirely supported by NHMFL users services via its core grant)			<b>P11506</b>	Magnetostrain in UPT_2Si_2	Condensed Matter Physics	3	25
Marcelo Jaime (S)	C	National High Magnetic Field Laboratory (NHMFL)	Physics								
Geetha Balakrishnan (S)	PI	University of Warwick	Physics	European Research Commission			<b>P09597</b>	Quantum oscillations in a topological insulator	Condensed Matter Physics	1	9
Marcelo Jaime (S)	C	National High Magnetic Field Laboratory (NHMFL)	Physics								
Hsu Liu (G)	C	University of Cambridge	Physics								
Suchitra Sebastian (S)	C	University of Cambridge	Physics								
John Mitchell (S)	PI	Argonne National Laboratory	Materials Science Division	DOE - Department of Energy	LDRD – Laboratory Directed R&D	XW5D	<b>P09568</b>	Spin state transition, multifunctionality and percolation in La <sub>1-x</sub> Sr <sub>x</sub> CoO <sub>3</sub>	Condensed Matter Physics	1	10
Shalinee Chikara (P)	C	National High Magnetic Field Laboratory (NHMFL)	NHMFL-PFF								
Neil Harrison (S)	C	National High Magnetic Field Laboratory (NHMFL)	Physics								
Marcelo Jaime (S)	C	National High Magnetic Field Laboratory (NHMFL)	Physics								
John Singleton (S)	C	National High Magnetic Field Laboratory (NHMFL)	Physics								
Vivien Zapf (S)	C	National High Magnetic Field Laboratory (NHMFL)	Physics								

# Appendix VI – User Proposals

Jamie Manson (S)	PI	Eastern Washington University	Chemistry and Biochemistry	NSF - National Science Foundation	DMR – Division of Materials Research	1306158	<b>P09541</b>	Using magnetization to explore spin-dimensionality in Cu(II) coordination polymers	Condensed Matter Physics	1	5
Jamie Brambleby (G)	C	University of Warwick	Physics								
Paul Goddard (S)	C	University of Warwick	Department of Physics								
John Singleton (S)	C	National High Magnetic Field Laboratory (NHMFL)	Physics								
Mun Chan (P)	PI	National High Magnetic Field Laboratory (NHMFL)	Pulsed field Facility	DOE - Department of Energy	Office of Science - BES – Basic Energy Sciences	LANLF100	<b>P08467</b>	The ground-state of the cuprate high-temperature superconductor HgBa <sub>2</sub> CuO <sub>4+d</sub>	Condensed Matter Physics	2	39
Jonathan Betts (S)	C	National High Magnetic Field Laboratory (NHMFL)	NHMFL-PFF								
Neil Harrison (S)	C	National High Magnetic Field Laboratory (NHMFL)	Physics								
Ross McDonald (S)	C	National High Magnetic Field Laboratory (NHMFL)	Physics								
Brad Ramshaw (S)	C	Cornell University	Laboratory of Atomic and Solid State Physics								
Arkady Shehter (S)	C	National High Magnetic Field Laboratory (NHMFL)	NHMFL, DC Field Facility								
Philip Moll (S)	PI	ETH Zürich	MPI Chemical Physics of Solids	No other support (i.e. this experiment is entirely supported by NHMFL users services via its core grant)			<b>P08435</b>	Field Induced density wave in CeRhIn <sub>5</sub> and CeCoIn <sub>5</sub>	Condensed Matter Physics	3	40
Fedor Balakirev (S)	C	National High Magnetic Field Laboratory (NHMFL)	PFF								
Luis Balicas (S)	C	National High Magnetic Field Laboratory (NHMFL)	Condensed Matter Experiment								

# Appendix VI – User Proposals

Bertram Batlogg (S)	C	ETH Zürich	Physics								
Eric Bauer (S)	C	Los Alamos National Laboratory	MST-10								
Audrey Grockowiak (S)	C	National High Magnetic Field Laboratory (NHMFL)	DC Field/CMS								
Toni Helm (P)	C	Max Planck Institute	Physics of Quantummaterials								
Filip Ronning (S)	C	Los Alamos National Laboratory	MPA-CMMS								
Kent Shirer (P)	C	Max Planck Institute for Chemical Physics of Solids	Microstructured Quantum Matter and Physics of Quantum Materials								
Stan Tozer (S)	C	National High Magnetic Field Laboratory (NHMFL)	Physics								
Haiyan Wang (S)	PI *	Texas A&M University	Electrical and Computer Engineering	DOE - Department of Energy	Office of Science - BES – Basic Energy Sciences	LANLE8L54	<b>P07300</b>	High Magnetic Field properties of 11 Iron-Based Superconducting Thin Films	Engineering	1	5
Boris Maiorov (S)	C	Los Alamos National Laboratory	MPA-STC								
Masashi Miura (S)	C	Seikei University	Graduate School of Science and Technology								
Doan Nguyen (S)	PI	National High Magnetic Field Laboratory (NHMFL)	Pulsed Field Facility	No other support (i.e. this experiment is entirely supported by NHMFL users services via its core grant)			<b>P07288</b>	Testing and Training of pulsed magnets	Magnets, Materials, Testing, Instrumentation	1	8
Jonathan Betts (S)	C	National High Magnetic Field Laboratory (NHMFL)	NHMFL-PFF								
Filip Ronning (S)	PI	Los Alamos National Laboratory	MPA-CMMS	DOE - Department of Energy	Office of Science - BES – Basic Energy Sciences	E8C1	<b>P02510</b>	Pulsed field transport measurements of nano-machined Ce-based compounds	Condensed Matter Physics	1	5
Fedor Balakirev (S)	C	National High Magnetic Field Laboratory (NHMFL)	PFF								
Luis Balicas (S)	C	National High Magnetic Field Laboratory (NHMFL)	Condensed Matter Experiment								

# Appendix VI – User Proposals

Bertram Batlogg (S)	C	ETH Zürich	Physics							
Eric Bauer (S)	C	Los Alamos National Laboratory	MST-10							
Marcelo Jaime (S)	C	National High Magnetic Field Laboratory (NHMFL)	Physics							
Ross McDonald (S)	C	National High Magnetic Field Laboratory (NHMFL)	Physics							
Philip Moll (S)	C	ETH Zürich	MPI Chemical Physics of Solids							
Ian Fisher (S)	PI	Stanford University	Applied Physics	DOD - Department of Defense	U.S. Air Force	<b>P02297</b>	High-field study of Superconducting thallium doped lead telluride (Pb <sub>1-x</sub> Tl <sub>x</sub> Te)	Condensed Matter Physics	1	12
Paula Giraldo Gallo (P)	C	National High Magnetic Field Laboratory (NHMFL)	Physics							
Ross McDonald (S)	C	National High Magnetic Field Laboratory (NHMFL)	Physics							
Scott Riggs (S)	C	National High Magnetic Field Laboratory (NHMFL)	CMS							
Maxwell Shapiro (G)	C	Stanford University	Applied Physics							
Philip Walmsley (P)	C	Stanford University	Applied physics - GLAM							
Bellave Shivaram (S)	PI	University of Virginia	Physics	No other support (i.e. this experiment is entirely supported by NHMFL users services via its core grant)		<b>P02054</b>	High Field Ultrasonic Studies and Torque Magnetometry in Heavy Electron Materials	Condensed Matter Physics	2	8
Eric Bauer (S)	C	Los Alamos National Laboratory	MST-10							
Ryan Baumbach (S)	C	National High Magnetic Field Laboratory (NHMFL)	CMS							
Marcelo Jaime (S)	C	National High Magnetic Field Laboratory (NHMFL)	Physics							

# Appendix VI – User Proposals

Brian Maple (S)	C	University of California, San Diego	Inst for Pure & Applied Physical Sciences			
Ross McDonald (S)	C	National High Magnetic Field Laboratory (NHMFL)	Physics			
John Singleton (S)	C	National High Magnetic Field Laboratory (NHMFL)	Physics			
Dagmar Weickert (S)	C	National High Magnetic Field Laboratory (NHMFL)	MPA-Mag			
				<b>Total Proposals:</b>	<b>Experiments:</b>	<b>Days:</b>
				50	72	612

\* = A new PI for the reporting year.

PI = Principal Investigator; C = Collaborator

S = Senior Personnel; P = Postdoc; G = Graduate Student; U = Undergraduate Student; T = Technician, programmer

2017

Florida State University ▪ University of Florida ▪ Los Alamos National Laboratory

Supported by the National Science Foundation and the State of Florida

