

PAPER • OPEN ACCESS

Unusual Magnetic Response of an $S = 1$ Antiferromagnetic Linear-Chain Material

To cite this article: Jian-Sheng Xia *et al* 2018 *J. Phys.: Conf. Ser.* **969** 012121

View the [article online](#) for updates and enhancements.

Related content

- [DETECTION OF A FINE-SCALE DISCONTINUITY OF PHOTOSPHERIC MAGNETIC FIELDS ASSOCIATED WITH SOLAR CORONAL LOOP BRIGHTENINGS](#)
Donguk Song, Jongchul Chae, Soyoung Park *et al.*
- [The phase diagram and critical properties of the two-dimensional anisotropic XY model](#)
A S T Pires, L S Lima and M E Gouvêa
- [Twisted boundary conditions of quantum spin chains near the Gaussian fixed points](#)
A Kitazawa

Unusual Magnetic Response of an $S = 1$ Antiferromagnetic Linear-Chain Material

Jian-Sheng Xia¹, Andrzej Ozarowski², Peter M. Spurgeon³,
Adora G. Graham³, Jamie L. Manson³, Mark W. Meisel¹

¹Department of Physics and the National High Magnetic Field Laboratory, University of Florida, Gainesville, FL 32611-8440, USA

²National High Magnetic Field Laboratory, Florida State University, Tallahassee, FL 32310, USA

³Department of Chemistry and Biochemistry, Eastern Washington University, Cheney, WA 99004, USA

E-mail: meisel@phys.ufl.edu

Abstract.

An $S = 1$ antiferromagnetic polymeric chain, $[\text{Ni}(\text{HF}_2)(3\text{-Clpy})_4]\text{BF}_4$ (py = pyridine), also referred to as NBCT, has previously been identified to have intrachain, nearest-neighbor antiferromagnetic interaction strength $J/k_B = 4.86$ K and single-ion anisotropy (zero-field splitting) $D/k_B = 4.3$ K, so the ratio $D/J = 0.88$ places this system close to the $D/J \approx 1$ gapless critical point between the topologically distinct Haldane and Large- D phases. The magnetization was studied over a range of temperatures, $50 \text{ mK} \leq T \leq 1 \text{ K}$, and magnetic fields, $B \leq 10 \text{ T}$, in an attempt to identify a critical field, B_c , associated with the closing of a gap, and the present work places an upper bound of $B_c \leq (35 \pm 10) \text{ mT}$. At higher fields, the observed magnetic response is qualitatively similar to the “excess” signal observed by other workers at 0.5 K and below 3 T . The high-field (up to 14.5 T), multi-frequency (nominally 200 GHz to 425 GHz) ESR spectra at 3 K reveal several features associated with the sample.

1. Introduction

After Haldane reported the fundamental differences between one-dimensional Heisenberg antiferromagnets with integer and half-integer spins [1, 2], theoretical [3–5] and experimental [6] activities focused on clarifying the magnetic phases and properties of a broad range of linear-chain magnets described by the Hamiltonian

$$\mathcal{H} = J \sum_i \{ [S_i^x S_{i+1}^x + S_i^y S_{i+1}^y + \lambda S_i^z S_{i+1}^z] + D (S_i^z)^2 + E [(S_i^x)^2 - (S_i^y)^2] \} - \vec{B} \cdot \overleftrightarrow{g} \cdot \vec{S} , \quad (1)$$

where J is the nearest-neighbor intrachain magnetic exchange parameter, D and E are the single-ion and rhombic anisotropies that are commonly referred to as zero-field splitting parameters arising from the crystal-field anisotropy, g is the Lande g -factor tensor, B is the applied magnetic field, λ is a parameter distorting the exchange, and the inevitable interchain coupling J' is not shown. For $S = 1$, the Haldane phase, which possesses an energy gap $\Delta = 0.41J$ when $D = 0$, and the Large- D phase [3, 7] have been established by magnetization [8, 9], EPR [10–14],



and inelastic neutron scattering studies [8, 15]. Recently, Brambleby *et al.* have demonstrated the power of employing a suite of experimental and numerical tools to untangle the single-ion anisotropy and exchange energies in the $S = 1$ quantum antiferromagnet $[\text{Ni}(\text{HF}_2)(\text{pyz})_2]\text{SbF}_6$, where pyz = pyrazine, which was identified to have $D/J \approx 1.3$ and long-range magnetic order near 12 K [16]. To date, no real material has been identified as being close to the quantum critical point of $D/J \approx 1$ while also avoiding long-range order at $T \ll J/k_B$. This region of the phase diagram has attracted wide theoretical and numerical attention [17–27] and the ground-state properties have not been unambiguously resolved. Nonetheless, there is converging consensus that the Haldane gap closes and the Large- D gap opens at a gapless critical point, $(D/J)_c = 0.97$ when $\lambda = 1$, between the two topologically distinct gapped phases with different parity. In other words, this particular quantum critical region remains without any candidate systems whose properties may provide insight into the measurable thermodynamic and electromagnetic properties. Resolving this lacuna will provide new perspectives into quantum critical phenomena, and such experimental-theoretical advances are being realized in other systems [28, 29].

This paper reports experimental magnetization and EPR data on an intriguing $S = 1$ polymeric chain material, $[\text{Ni}(\text{HF}_2)(3\text{-Clpy})_4]\text{BF}_4$ (py = pyridine) [30], Fig. 1, that appears to be located close to $(D/J)_c$. In 2012, $[\text{Ni}(\text{HF}_2)(3\text{-Clpy})_4]\text{BF}_4$, now sometimes referred to as NBCT, was synthesized and characterized by a wide-range of spectroscopies [30]. Most notably, muon-spin relaxation spectra relax monotonically, and the lack of oscillations or a shift in the base line are interpreted as indicating the absence of long-range magnetic order. The low-field $B = 0.1$ T, high-temperature ($T \geq 1.8$ K) magnetic susceptibility possessed an antiferromagnetic component, which could be fit to $J/k_B = 4.86$ K with $g = 2.1$, and a paramagnetic Curie-like component that might be associated with uncoupled Ni^{2+} spins and/or with $S = 1/2$ end-chain spins [5, 31–36]. In addition, analysis of the UV-vis spectra suggested $D/k_B \approx 4.3$ K, while heat capacity data were consistent with $D/J \lesssim 1$. Finally, magnetization data at $T = 0.5$ K and in $B < 3$ T revealed the presence of an “excess” amount of signal above the response measured at 1.6 K. The present studies were initiated to search for evidence of the critical field required to close a gap and to understand the origin of the magnetic signal at low temperatures.

2. Experimental Details

To experimentally explore the magnetization of $[\text{Ni}(\text{HF}_2)(3\text{-Clpy})_4]\text{BF}_4$, nominally 4 (± 1) mg of small cubic-like (with sides of a few mm), as-grown [30] polycrystalline pieces were randomly placed and rigidly held in one side of a mutual inductance cell, shown in Fig. 2, mounted to the dilution refrigerator operated in the Williamson Hall Annex of the High-B/T Facility of the National High Magnetic Field Laboratory (NHMFL) at the University of Florida. At a fixed temperature, the imbalance between the two secondary coils was monitored by a lock-in amplifier (Model NF5610B) at low frequency (52.93 Hz) and low ac field (0.1 mT) while sweeping a superconducting solenoid at a constant rate of 50 mT/min. The phase setting was adjusted to minimize one channel of the lock-in amplifier and remained constant for all runs. The data acquisition of the in-phase and out-of-phase voltages (V_{in} and V_{out}) takes about 3.5 hours as the field is swept to or from 10 T. To within experimental resolution, no magnetic hysteresis was established at 50 mK, but the starting and final voltages differ by a few μV due to changes in the level of the liquid helium in the bath. With the absence of detectable hysteresis at the lowest temperature, the runs at higher temperatures were performed by sweeping the field in only one direction. When the runs with the sample were complete, the sample was removed, and the measurements were repeated so “sample-in minus sample-out” analysis, commonly employed in pulsed field experiments, could be performed. It is noteworthy the sample was cooled by a liquid of pure ^3He , which is known to provide excellent thermal coupling down to low temperatures and in high magnetic fields [39, 40], and a similar arrangement was used to cool another molecule-based magnetic system down to 40 mK [41]. In fact, the solvent associated with the present

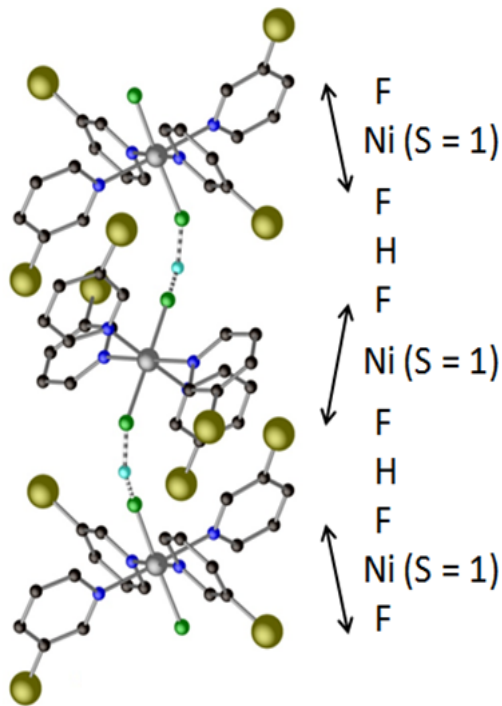

Figure 1. The crystal structure of $[\text{Ni}(\text{HF}_2)(3\text{-Clpy})_4]\text{BF}_4$ (py = pyridine), also known as NBCT, space group $P2_1/c$, resembles a linear chain of octahedrally coordinated Ni^{2+} ions linked by F–H–F bridges along the c -axis [30]. The 3-Clpyridine ($\text{C}_5\text{H}_4\text{ClN}$) ligands isolate the chains from neighboring ones, and the BF_4 anions required for charge neutralization are omitted for clarity. The local environment of the Ni ions switches axial orientation along the chain, as sketched by the arrows, and is an aspect reminiscent of the staggered g -tensor in $\text{Ni}(\text{C}_2\text{H}_8\text{N}_2)_2\text{NO}_2(\text{ClO}_4)$ (commonly referred to as NENP) [37, 38].

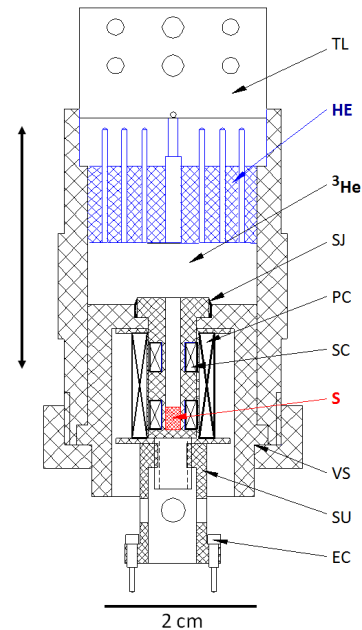

Figure 2. The cell used for magnetization studies is mostly made of plastics and is oriented along the direction of the magnetic fields represented by the left arrow. The main components are: a Ag thermal link (TL), with a Ag sintered powder heat exchanger (HE), a bath of pure ^3He (fill line not shown) in direct contact with the sample (S), a Stycast 1266 joint (SJ) to the Kel-F (Neoflon PCTFE) housing, a primary coil (PC) consisting of 2100 turns of nominally $76\ \mu\text{m}$ diameter NbTi multi-filamentary wire, a set of secondary coils (SC) each with 2500 turns of $51\ \mu\text{m}$ diameter Cu wire, a lower plastic-to-plastic (reusable) vacuum seal (VS), and a supporting tower (SU) for the electrical connections (EC).

sample [30] eroded the thin Stycast 1266 wall of the previous cell, and a new one was constructed from an old piece of Kel-F by 3M (now available as Daikin Neoflon PCTFE).

3. Results and Discussion

The isothermal, low-field dependences of the magnitudes ($= \sqrt{V_{\text{in}}^2 + V_{\text{out}}^2}$), after background subtraction, are shown in Fig. 3. The overall experimental uncertainty, which is a combination of background subtraction and the bath level adjustment, is represented by the bar designating “+/-”. The legend identifies the temperatures, and two runs at 50 mK were made. One 50 mK run was made at the start of the experiment (shown in blue), while the other 50 mK run (shown in black), which followed the measurement at 1000 mK, was made at the end of

the study with the sample present. One striking aspect of the data is the apparent similarity of the data sets for $T \lesssim 400$ mK, and at first glance, this result seems to indicate the sample is not being cooled to the lowest temperatures. However, it is important to stress several points. Firstly, as previously mentioned, similar samples have been reproducibly cooled in other studies [41]. Secondly, difficulty in cooling a sample may indicate an increase of the specific heat near a quantum phase transition, where the accumulation of entropy is generally accepted as a generic consequence [43,44]. In addition, the data at the lowest fields suggest the magnetic signal is absent or exceedingly small. Although the sensitivity of this cell is considered to be comparable to the one used in other work [41], the dynamic range of the detection coils was not quantitatively established, so a definitive value for the critical field necessary to close a gap, B_c , cannot be determined. Nevertheless, an upper bound of $B_c \leq (35 \pm 10)$ mT can be set as shown in Fig. 3. This result can be compared to the extrapolated Haldane gap values near $(D/J)_c = 0.968$, as given by Hu *et al.* [21], and the result is $B_c = 46$ mT, when using the aforementioned values for the parameters. In general, the “excess” signal, at $T = 0.5$ K and $B < 3$ T, reported by others [30] has been qualitatively reproduced in this work. Furthermore, the temperature-field dependences of the data sets shown in Fig. 3 cannot be modeled by non-interacting $S = 1/2$ end-chain spins. Quantitative insight about the magnetic response at low temperatures and in low magnetic fields will require data acquired with oriented crystals, where the impact of a staggered g -tensor, Fig. 1, may be revealed [37,38].

High-field, high-frequency EPR spectra were acquired with a randomly-packed, purposely-powdered sample, with a total mass of approximately 50 mg, that was synthesized separately from the ones used in the magnetization studies. Using a constant flow cryostat operating at $3 \text{ K} \leq T \leq 20 \text{ K}$, the experiments were conducted with a home-built spectrometer at the electromagnetic resonance (EMR) facility of the NHMFL at Florida State University. The details

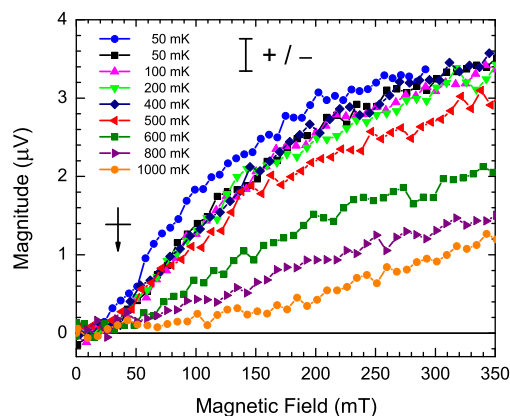

Figure 3. Magnitudes of the voltages, after background subtraction, are shown as a function of the magnetic field, and the uncertainty is given by the “+/-” bar. The two runs at 50 mK are discussed in the text. The degeneracy of the data sets for $T \lesssim 400$ mK is conjectured to be evidence of the increase of entropy, see text. A critical field necessary to close a gap, if present, has an upper bound of $B_c \leq (35 \pm 10)$ mT.

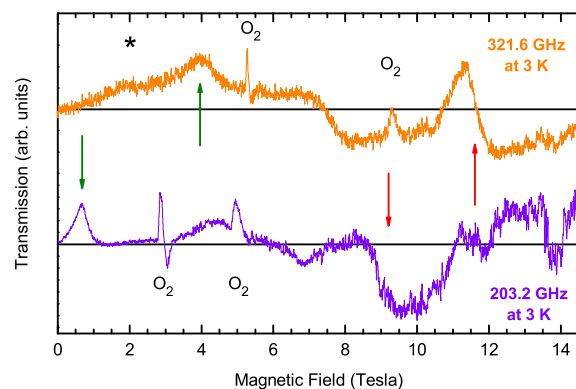

Figure 4. The EPR transmission signals at 321.6 GHz (top and orange trace) and 203.2 GHz (bottom and purple trace) are shown as a function of magnetic field. The arrows designate the features considered to arise from the Ni-chain, while fingerprints known to be indicative of trace amounts of oxygen in solid air are labeled as O_2 [42]. A weak feature, marked by an asterisk, may be a “forbidden” transition [14].

of the transmission-type instrument and spectrometer are described elsewhere [45], and for this work, spectra were acquired at several frequencies ranging from 203 GHz to 425 GHz. The spectra taken at $T = 3$ K and at 203.2 GHz and 321.6 GHz are shown in Fig. 4, where the broad features associated with the Ni-chains are identified. Since the thermal energy at $T = 3$ K is similar to the J and D energies, the full dynamics of the chain are not developed, especially when considering the gap is exceedingly small, $\Delta/k_B \lesssim 60$ mK, if it exists. The limited EPR data sets presented herein preclude any extended analysis that can resolve the magnetic parameters of the Hamiltonian, Eq. 1, as commonly done in these kinds of systems [11–14, 46–48]. However to date, no other EPR studies of NBCT have been reported, so typical spectra are included, Fig. 4, to serve as benchmarks for future investigations that will presumably employ oriented single crystal samples which can be studied over a wider range of frequency and temperature.

4. Conclusions

In summary, the magnetic properties of $[\text{Ni}(\text{HF}_2)(3\text{-Clpy})_4]\text{BF}_4$ (py = pyridine) exhibit unusual behavior at low temperatures and in low fields. An upper bound for the critical field required to close a gap is established, $B_c \leq (35 \pm 10)$ mT, and this value is close to the one predicted for a Haldane system [21], 46 mT, when using the experimentally established values of J , D , and g . In low fields, the magnetic signal increases with decreasing temperature for 400 mK $\lesssim T \lesssim 800$ mK but, to within experimental resolution, is independent of temperature for 50 mK $\leq T \leq 400$ mK. This observation is consistent with a significant increase in the specific heat arising from the accumulation of entropy in the vicinity of the quantum critical transition near $D/J \approx 1$. These results provide new experimental access to this quantum critical regime, where the D/J value might be tunable by pressure [49–53] and/or chemical modifications such as deuteration [54, 55]. Ultimately, future inelastic neutron scattering studies may clarify how the ground-state of $[\text{Ni}(\text{HF}_2)(3\text{-Clpy})_4]\text{BF}_4$ compares to theoretical phase diagrams [26, 27].

Acknowledgments

This work was supported by the NSF through DMR-1202033 and DMR-1708410 (MWM), DMR-1703003 (JLM), and DMR-1157490 (NHMFL). We acknowledge communications with M. Hagiwara, D. M. Pajerowski, M. Orendáč, A. Orendáčová, E. Čížmár, and V. N. Glazkov.

References

- [1] Haldane F 1983 *Physics Letters A* **93** 464–468
- [2] Haldane F D M 1983 *Phys. Rev. Lett.* **50**(15) 1153–1156
- [3] Schulz H J 1986 *Phys. Rev. B* **34**(9) 6372–6385
- [4] Affleck I, Kennedy T, Lieb E H and Tasaki H 1987 *Phys. Rev. Lett.* **59**(7) 799–802
- [5] Affleck I 1989 *Journal of Physics: Condensed Matter* **1** 3047
- [6] Yamashita M, Ishii T and Matsuzaka H 2000 *Coordination Chemistry Reviews* **198** 347–366
- [7] Botet R, Jullien R and Kolb M 1983 *Phys. Rev. B* **28**(7) 3914–3921
- [8] Renard J P, Verdaguer M, Regnault L P, Erkelens W A C, Rossat-Mignod J and Stirling W G 1987 *EPL (Europhysics Letters)* **3** 945
- [9] Orendáč M, Orendáčová A, Černák J, Feher A, Signore P J C, Meisel M W, Merah S and Verdaguer M 1995 *Phys. Rev. B* **52**(5) 3435–3440
- [10] Orendáč M, Zvyagin S, Orendáčová A, Sieling M, Lüthi B, Feher A and Meisel M W 1999 *Phys. Rev. B* **60**(6) 4170–4175
- [11] Sieling M, Löw U, Wolf B, Schmidt S, Zvyagin S and Lüthi B 2000 *Phys. Rev. B* **61**(1) 88–91
- [12] Hagiwara M 2002 *Molecular Physics* **100** 1489–1495
- [13] Čížmár E, Ozerov M, Ignatchik O, Papageorgiou T P, Wosnitza J, Zvyagin S A, Krzystek J, Zhou Z, Landee C P, Landry B R, Turnbull M M and Wikaira J L 2008 *New Journal of Physics* **10** 033008
- [14] Smirnov A I, Glazkov V N, Kashiwagi T, Kimura S, Hagiwara M, Kindo K, Shapiro A Y and Demianets L N 2008 *Phys. Rev. B* **77**(10) 100401
- [15] Zheludev A, Nagler S E, Shapiro S M, Chou L K, Talham D R and Meisel M W 1996 *Phys. Rev. B* **53**(22) 15004–15009

- [16] Brambleby J, Manson J L, Goddard P A, Stone M B, Johnson R D, Manuel P, Villa J A, Brown C M, Lu H, Chikara S, Zapf V, Lapidus S H, Scatena R, Macchi P, Chen Y S, Wu L C and Singleton J 2017 *Phys. Rev. B* **95**(13) 134435
- [17] Sakai T and Takahashi M 1990 *Phys. Rev. B* **42**(7) 4537–4543
- [18] Tzeng Y C and Yang M F 2008 *Phys. Rev. A* **77**(1) 012311
- [19] Albuquerque A F, Hamer C J and Oitmaa J 2009 *Phys. Rev. B* **79**(5) 054412
- [20] Pollmann F, Turner A M, Berg E and Oshikawa M 2010 *Phys. Rev. B* **81**(6) 064439
- [21] Hu S, Normand B, Wang X and Yu L 2011 *Phys. Rev. B* **84**(22) 220402
- [22] Pollmann F, Berg E, Turner A M and Oshikawa M 2012 *Phys. Rev. B* **85**(7) 075125
- [23] Li W, Weichselbaum A and von Delft J 2013 *Phys. Rev. B* **88**(24) 245121
- [24] Langari A, Pollmann F and Siahatgar M 2013 *Journal of Physics: Condensed Matter* **25** 406002
- [25] Wierschem K and Sengupta P 2014 *Phys. Rev. Lett.* **112**(24) 247203
- [26] Wierschem K and Sengupta P 2014 *Modern Physics Letters B* **28** 1430017
- [27] Tzeng Y C, Onishi H, Okubo T and Kao Y J 2017 *Phys. Rev. B* **96**(6) 060404
- [28] Si Q and Steglich F 2010 *Science* **329** 1161–1166
- [29] Kinross A W, Fu M, Munsie T J, Dabkowska H A, Luke G M, Sachdev S and Imai T 2014 *Phys. Rev. X* **4**(3) 031008
- [30] Manson J L, Baldwin A G, Scott B L, Bendix J, Del Sesto R E, Goddard P A, Kohama Y, Tran H E, Ghannadzadeh S, Singleton J, Lancaster T, Möller J S, Blundell S J, Pratt F L, Zapf V S, Kang J, Lee C, Whangbo M H and Baines C 2012 *Inorganic Chemistry* **51** 7520–7528
- [31] Hagiwara M, Katsumata K, Affleck I, Halperin B I and Renard J P 1990 *Phys. Rev. Lett.* **65**(25) 3181–3184
- [32] Glarum S H, Geschwind S, Lee K M, Kaplan M L and Michel J 1991 *Phys. Rev. Lett.* **67**(12) 1614–1617
- [33] Avenel O, Xu J, Xia J S, Xu M F, Andraka B, Lang T, Moyland P L, Ni W, Signore P J C, van Woerkens C M C M, Adams E D, Ihas G G, Meisel M W, Nagler S E, Sullivan N S, Takano Y, Talham D R, Goto T and Fujiwara N 1992 *Phys. Rev. B* **46**(13) 8655–8658
- [34] Avenel O, Xu J, Xia J, Xu M F, Andraka B, Lang T, Moyland P, Ni W, Signore P, Woerkens C, Adams E, Ihas G, Meisel M, Nagler S, Sullivan N, Takano Y, Talham D, Goto T and Fujiwara N 1992 *Journal of Low Temperature Physics* **89** 547–550
- [35] Batista C D, Hallberg K and Aligia A A 1998 *Phys. Rev. B* **58**(14) 9248–9251
- [36] Granroth G E, Maegawa S, Meisel M W, Krzystek J, Brunel L C, Bell N S, Adair J H, Ward B H, Fanucci G E, Chou L K and Talham D R 1998 *Phys. Rev. B* **58**(14) 9312–9315
- [37] Chiba M, Ajiro Y, Kikuchi H, Kubo T and Morimoto T 1991 *Phys. Rev. B* **44**(6) 2838–2841
- [38] Huang H and Affleck I 2004 *Phys. Rev. B* **69**(18) 184414
- [39] Hammel P C, Roukes M L, Hu Y, Gramila T J, Mamiya T and Richardson R C 1983 *Phys. Rev. Lett.* **51**(23) 2124–2127
- [40] Schuhl A, Maegawa S, Meisel M W and Chapellier M 1987 *Phys. Rev. B* **36**(13) 6811–6836
- [41] Orendáčová A, Čížmár E, Sedláková L, Hanko J, Kajňáková M, Orendáč M, Feher A, Xia J S, Yin L, Pajeroski D M, Meisel M W, Zeleňák V, Zvyagin S and Wosnitza J 2009 *Phys. Rev. B* **80**(14) 144418
- [42] Pardi L A, Krzystek J, Telser J and Brunel L C 2000 *Journal of Magnetic Resonance* **146** 375–378
- [43] Vidal G, Latorre J I, Rico E and Kitaev A 2003 *Phys. Rev. Lett.* **90**(22) 227902
- [44] Zhu L, Garst M, Rosch A and Si Q 2003 *Phys. Rev. Lett.* **91**(6) 066404
- [45] Hassan A, Pardi L, Krzystek J, Sienkiewicz A, Goy P, Rohrer M and Brunel L C 2000 *Journal of Magnetic Resonance* **142** 300–312
- [46] Hagiwara M, Katsumata K, Yamada I and Suzuki H 1996 *Journal of Physics: Condensed Matter* **8** 7349
- [47] Fanucci G E, Krzystek J, Meisel M W, Brunel L C and Talham D R 1998 *Journal of the American Chemical Society* **120** 5469–5479
- [48] Furuya S C, Oshikawa M and Affleck I 2011 *Phys. Rev. B* **83**(22) 224417
- [49] Zaliznyak I A, Dender D C, Broholm C and Reich D H 1998 *Phys. Rev. B* **57**(9) 5200–5204
- [50] Oosawa A, Kakurai K, Osakabe T, Nakamura M, Takeda M and Tanaka H 2004 *Journal of the Physical Society of Japan* **73** 1446–1449
- [51] Rüegg C, Furrer A, Sheptyakov D, Strässle T, Krämer K W, Güdel H U and Mélési L 2004 *Phys. Rev. Lett.* **93**(25) 257201
- [52] Hong T, Garlea V O, Zheludev A, Fernandez-Baca J A, Manaka H, Chang S, Leao J B and Poulton S J 2008 *Phys. Rev. B* **78**(22) 224409
- [53] Thede M, Mannig A, Månsson M, Hüvonen D, Khasanov R, Morenzoni E and Zheludev A 2014 *Phys. Rev. Lett.* **112**(8) 087204
- [54] Tsujii H, Honda Z, Andraka B, Katsumata K and Takano Y 2005 *Phys. Rev. B* **71**(1) 014426
- [55] Goddard P A, Singleton J, Maitland C, Blundell S J, Lancaster T, Baker P J, McDonald R D, Cox S, Sengupta P, Manson J L, Funk K A and Schlueter J A 2008 *Phys. Rev. B* **78**(5) 052408