

PAPER • OPEN ACCESS

Frequency Loss Induced Quench (FLIQ) Protection System for Insulated Coil REBCO Magnets

Recent citations

- [Electrical Model of Frequency Loss Induced Quench Protection System for High Temperature Superconducting Magnets](#)
Kikelomo Ijagbemi *et al*

To cite this article: K Ijagbemi *et al* 2020 *IOP Conf. Ser.: Mater. Sci. Eng.* **755** 012131

View the [article online](#) for updates and enhancements.



ECS **240th ECS Meeting**
Digital Meeting, Oct 10-14, 2021
We are going fully digital!
Attendees register for free!
REGISTER NOW

Frequency Loss Induced Quench (FLIQ) Protection System for Insulated Coil REBCO Magnets

K Ijagbemi^{1,2}, D Davis¹, E Stiers¹, H Bai¹, S Pamidi^{2,3}

¹ National High Magnetic Field Laboratory, Tallahassee, FL 32310, USA.

² FAMU-FSU College of Engineering, Tallahassee, FL 32310, USA

³ Center for Advanced Power Systems, Florida State University, Tallahassee, FL 32310, USA

kikelomo1.ijagbemi@famuc.edu

Abstract. Frequency Loss Induced Quench (FLIQ) system is a novel technique that relies on generating AC losses to uniformly heat a superconducting coil to induce a safe and rapid quench. FLIQ drives an imbalance in the transport current between two or more sections of the magnet. To drive the imbalance, FLIQ uses an H-bridge design with Insulated Gate Bipolar Transistor (IGBT)s, whose gates are controlled based on the current feedback, allowing the system to operate at resonance. Simulation of estimated energy per volume deposited by FLIQ and sensitivity analysis of its parameters are performed and the results presented. Application of FLIQ for protection of high temperature superconducting (HTS) magnet systems is described.

1. Introduction

A significant challenge to protection of High Temperature Superconductors (HTS) is their high critical temperature (T_c), slow normal zone propagation and stability, particularly in a magnet device with sufficient stored energy [1], [2]. In the event of a quench, low normal zone propagation velocities and high stability of REBCO wires result in localized damage due to excessive hot spot temperature. The current in the magnet must be rapidly reduced to prevent damage caused by peak hot-spot temperature or excessive mechanical strain. To protect magnets wound with REBCO tapes, a large amount of energy is required to raise the temperature of a significant fraction of the conductor in the magnet above the local T_c , rapidly increasing the magnet resistance, to dissipate the stored energy throughout the entire volume of the coil rather than primarily in a localized resistive normal zone [3]. This limits the peak temperature of the localized hot-spot, while raising the average temperature of the magnet, reducing thermal gradients.

Different methods are employed to reduce the magnet current during a quench and these methods include connecting an external shunt resistor, which is not desirable because the high voltage across the magnet terminals [5]. Another technique is the use of protection heaters to increase the temperature of the magnet coil above the T_c and as a result, the thermal energy is more evenly distributed throughout the magnet coil [6]. The downside to this method is its inadequacy in quickly depositing sufficient energy needed for HTS magnets as it depends on thermal diffusion. The generated heat needs to diffuse through the insulation to get to the windings resulting in a delay that may be too slow for some types of HTS magnets. Quench heaters are part of the coil geometry and safe operation of the magnet is affected when they breakdown [7].

Another method is Coupling Loss Induced Quench (CLIQ), which distributes the magnetic energy by driving an imbalance in the transport current between two or more sections of the magnet generating inter-filament and inter-strand coupling-losses [8,9]. In CLIQ based quench protection systems, to increase the available energy, capacitance of the system must be increased, which reduces the excitation frequency, or the voltage must be increased, which raises safety concerns. Depending on the requirements of the magnet system, multiple CLIQ systems may be employed to deliver enough energy to the coil. All these methods



are effective for low temperature superconducting magnets, but they provide only a marginal quench protection for recently developed high temperature superconducting magnets and are not adequate in rapidly distributing a large amount of thermal energy to the windings of an REBCO magnet [10].

The motivation for this work is the requirement for an improved quench protection system suitable for REBCO magnet coils. The Frequency Loss Induced Quench (FLIQ) based protection system includes coupling of a current imbalance source to at least one coil subsection of a REBCO magnet and operating the current source to induce a current imbalance in at least one subsection of the magnet [11]. The imbalance establishes a high frequency change in the magnetic field of the REBCO magnet coil. This high frequency change results in induction heating in the REBCO magnet coil to induce a controlled quench. To achieve this, FLIQ uses an H-bridge design with Insulated Gate Bipolar Transistor (IGBT)s, whose gates are driven based on its current feedback control. The current flowing through the load is used to generate the switching logic of the IGBTs. Therefore, as magnet load change due to iron saturation, current redistribution, screening currents, FLIQ maintains continual resonance with excitation current as the IGBTs switch at the frequency of the excitation current. Two gate drivers with an inverting and a non-inverting output are employed to drive the gates of two IGBTs at a time.

FLIQ does not rely on a large capacitor bank unlike in CLIQ, which limits the resonant frequency in protection. FLIQ can operate with low capacitance and at high resonant frequency introducing large oscillations in the transport current, and thereby depositing more heat energy in the coil faster than quench heaters can deliver. FLIQ system optimizes frequency, to deliver high power as current resonates at the frequency of the LC network connected across the bridge.

This paper discusses FLIQ and the estimation of energy deposition through eddy-current losses. This estimation is based on an electrical circuit model developed using MATLAB. The simulation does not account for hysteresis and coupling loss but determines the energy per unit volume delivered by the FLIQ system only when the coil is fully quenched and performs a sensitivity analysis.

2. Modelling of FLIQ

When the FLIQ system is actuated, the IGBTs are controlled based on control signals generated as a result of the sensed current flowing through the center of the bridge. The current imbalance from FLIQ (I_F) is

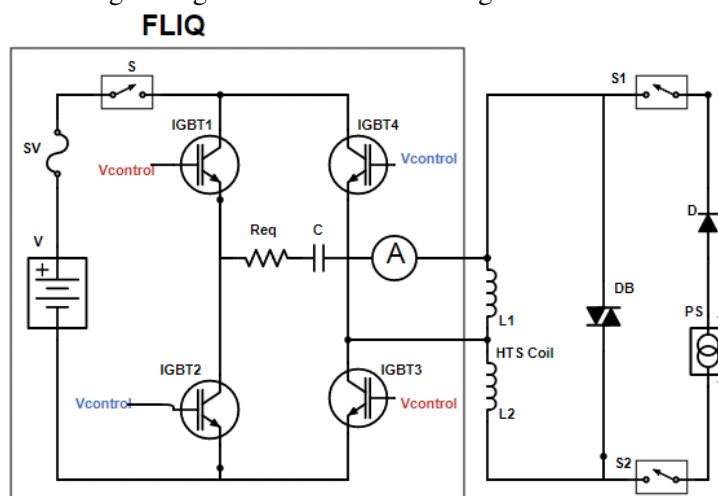

Figure 1. Schematic showing FLIQ connected to HTS coil

driven into the coil as in parallel aiding connection, which drives a high frequency change in the magnetic field of the HTS coil. The coil subsections that are not directly connected across the FLIQ system are exposed to the same rapid change in the magnetic field, but their response is phase shifted by 180° .

2.1. Equivalent Circuit

The circuit in Figure 1 has two sections of the HTS coil: L1 and L2. There is a mid-tap between L1 and L2 connecting one section to the FLIQ circuit. V is a battery voltage source. S is the switch that turns on the voltage source. SV protects the batteries from back flow of current. D is a blocking diode that protects the power supply, PS. S1 and S2 are contact switches that open when a quench is detected. Equivalent resistance, R_{eq} shown in Eq.1, is the sum of R_l the effective coil resistance, R_c the effective series resistance of the capacitor, R_{ct} the resistance of the wires in contact with coil, R_{int} the internal resistance of the battery and R_{GB} the switching resistance of two IGBTs.

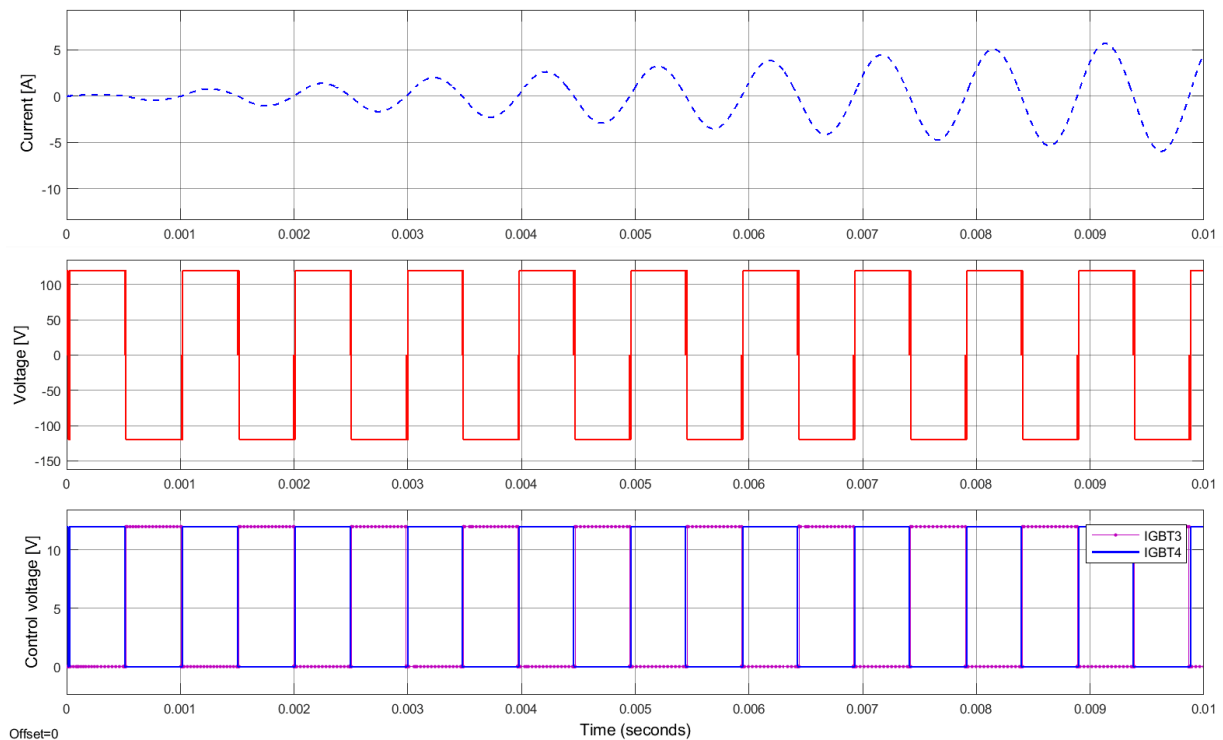

Figure 2. Simulated self-field operation of FLIQ at 120 V 1 kHz, showing current, voltage and IGBT control voltages

Based on the graph of I_c against V_{ce} in [12], internal resistance of each IGBT is estimated to be 0.0034Ω . As shown in Figure 1, the blue voltage control signal turns on IGBT 2 and 4, while the red voltage control signal turn on IGBT 1 and 3 to the voltage polarity across the RLC load. Therefore, only two IGBTs turn-on at the same time. R_{int} has an approximate value of $3 m\Omega$. The voltage across the IGBTs and other element in direct contact with the coil at discharge is small compared to the supply voltage. Hence, the simplification to an LCR circuit, V_s is the supply voltage, L_{eff} is the effective inductance, which is the equivalent inductance of two parallel opposing inductors, as expressed in Eq. 2. L_1 and L_2 are the self-inductances of coils 1 and 2, respectively. M is their mutual inductance of the two coils. If $V_s = V \cos(\omega t)$

and $w \cong \omega_0$, the current in the FLIQ circuit which is a sum of the natural and forced response is expressed in Eq. 3

$$R_{eq} = R_l + R_c + R_{ct} + R_{GB} \quad (1)$$

$$L_{eff} = \frac{(L_1 L_2 - M_{12}^2)}{(L_1 + L_2) + 2M_{12}} \quad (2)$$

$$I_F(V, \omega, t) = \left(\frac{1}{2L_{eff}\alpha b} \right) [bV\cos(\omega t) - Ve^{-\alpha t} [b\cosh(bt) + \alpha\sinh(bt)]] \quad (A) \quad (3)$$

$$V_s = L_{eff} \frac{dI_F}{dt} + I_F(t)R_{eq} + \frac{1}{C}q_F(t) \quad (4)$$

where $\alpha = R_{eq}/2L_{eff}$, $b = \sqrt{\alpha^2 - \omega_0^2}$, $\omega_0 = 1/\sqrt{L_{eff}C}$, t is time in seconds, α is the neper frequency, ω is frequency in rad/s, ω_0 is the resonant frequency, V_s is ac voltage supply, V is the amplitude of the voltage supply, R_{eq} is the equivalent resistance, C is the capacitance. Considering the prototype coil (REBCO 42-62) for 32 T insert at the NHMFL [13], to achieve resonance at 1 kHz, a capacitor of $0.2 \mu F$ is connected in series with the magnet.

Table 1. Main parameters of the REBCO magnet

Parameters	Value
Winding inner radius (mm)	42
Winding outer radius (mm)	62
Winding length (mm)	54
Number of modules (double pancake)	6
Turns/pancake (nominal)	100
Conductor/module (m)	65
Conductor total (m)	390
Coil Inductance (mH)	121.8

3. FLIQ Parameters

When coil quenches, internal resistance is maximized by introducing normal zones to more evenly heat the coils as current flows in the copper matrix of the superconductor. To estimate the amount of FLIQ energy per unit volume under the condition $I > I_c$; where $I = I_F + I_{tr}$ and I_{tr} is the transport current of the magnet. Skin effect reduces the area of copper where resistive loss is induced. Therefore, in respect to penetrated area, power per unit volume and energy per unit volume copper are given by (5) and (6) respectively. The high frequency resonance of FLIQ is shown in Figure 2

$$P(t) = I^2 \left(\frac{\rho_{cu}}{A_f^2} \right) = J^2 \rho \left(\frac{W}{m^3} \right) \quad (5)$$

$$E(t) = \int_0^T P(t) dt \quad (J/m^3) \quad (6)$$

where T is the FLIQ activation time and A_f is the area of copper penetrated by the high frequency current.

To estimate the lowest margin field and angle needed to quench a wire of the prototype coil, a value of T^* , which is the temperature scaling parameter as explained in [14] is chosen. The temperature scaling factor is used to determine the current sharing temperature, T_{cs} where transition begins to take place and more current runs through the normal conductor. Minimum field and angle is estimated to be 5T and 90° with enthalpy margin of 2.7 J/cm^3 . To get the temperature of the coil to T_{cs} at minimum field angle, FLIQ needs to operate at 24V 500 Hz for 0.5 s. Time of energy deposition reduces when voltage is increased.

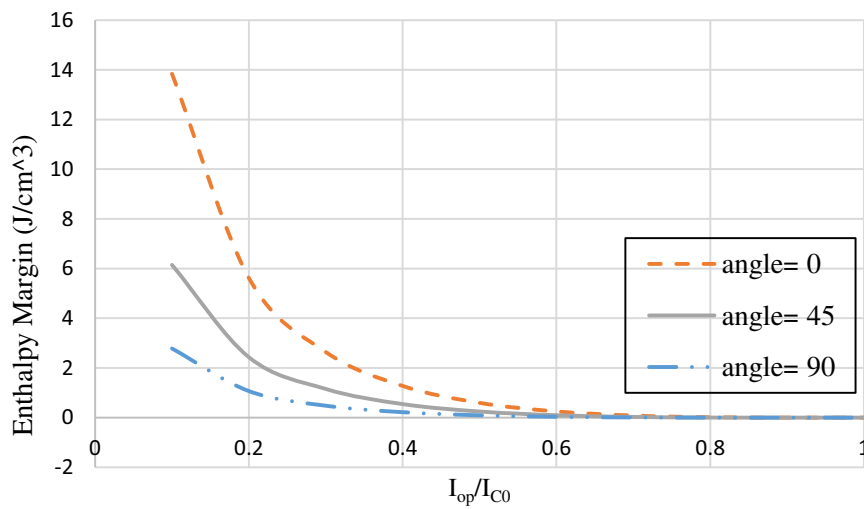

Figure 3. Enthalpy margin of REBCO coil at 5 T

3.1. Effects of supply voltage Vs

Eq. 4 shows I_F as a function V and I_F^2 is proportional to energy. As a result, the induced eddy current loss has direct effects on the quench efficiency and Eq. 6 can be resolved as shown in Eq.7. The amplitude of the supply voltage V , is directly proportional to the amount of energy per unit volume deposited by the FLIQ system. Figure 4 shows estimation of energy per unit volume of copper at $V=120 \text{ V}$, 240 V , and 360 V after operating FLIQ for 1 second at 8T. Doubling the voltage of the power supply increases the energy density by about 150%.

$$E(t) = V^2 \cdot \frac{\rho_{cu}}{A_f^2 2\alpha b L_{eff}} \cdot \int_0^T [b \cos(\omega t) - e^{-\alpha t} [b \cosh(bt) + a \sinh(bt)]] dt \quad (7)$$

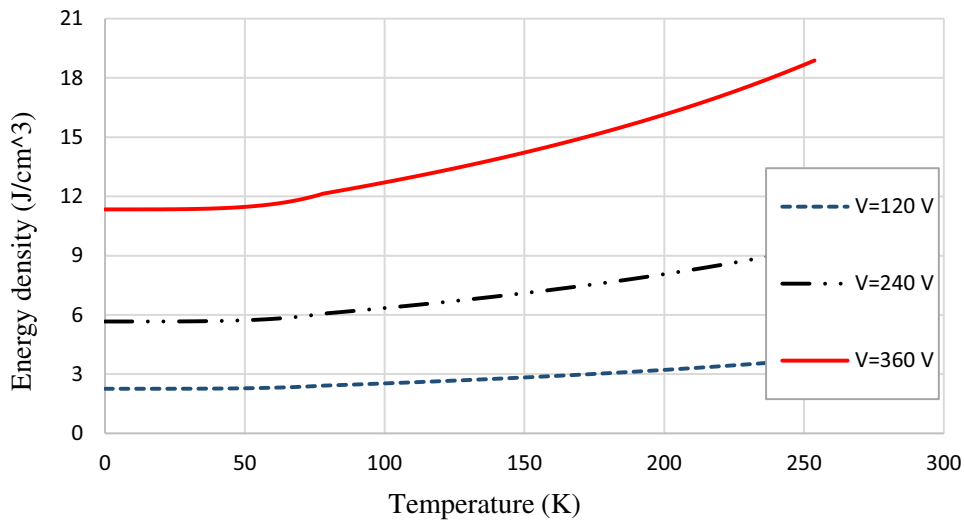

Figure 4. Energy density versus temperature at various voltages

3.2. Effects of frequency ω

For this estimation, $\omega \cong \omega_0$, which is the resonant frequency because the excitation frequency is the same as the resonant frequency in FLIQ. From Eq. 3, I_F is a function of ω , therefore the frequency dependence factor is $\omega = 2\pi f$. The dissipation also depends on resistivity at the temperature.

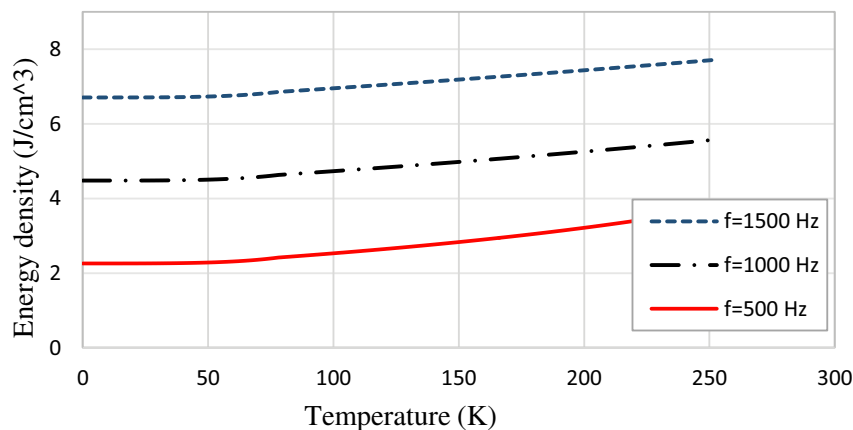

Figure 5. Energy density versus temperature at various frequency

3.3. Effects of magnetic field B

Relationship between magnetic field and resistivity is shown in Eq. 8. R_0 is resistivity at room temperature, $\alpha = 3.6095e^{-7}$ and $\beta = 5.2845e^{-11}$ are fit parameters and B is the field. Resistivity of copper directly proportional to the delivered energy at any field. As shown in Figure 6, field B has minimal effect on the delivered energy because β is very small.

$$\rho = R_0 * (1 + \alpha T^4) + \beta * B \quad (\Omega m) \quad (8)$$

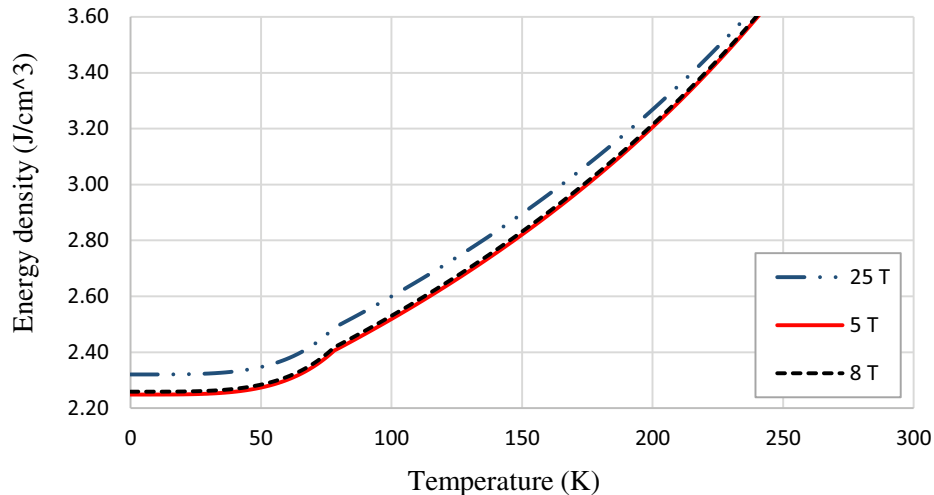

Figure 6. Energy density versus temperature at various magnetic fields

4. Conclusion

The Frequency Loss Induced Quench protection system is a novel quench protection technology that introduces high frequency current to generate and deposit large amount of energy in HTS coils. FLIQ operates at higher frequencies because its resonant circuit does not rely on a charged capacitor. Voltage of power supply and frequency in FLIQ have significant effect on energy density while the magnetic field does not have much effect. FLIQ can deliver up to tens of J/cm^3 in the copper matrix within 1 s of its activation. The simulation performed to estimate the energy density delivered when the coil quenches. To optimize the performance of FLIQ under different conditions, simulation and estimation of additional heat energy generated from other losses such as coupling loss and hysteresis losses will be carried out in the future.

5. References

- [1] Maeda H and Yanagisawa Y 2014 Recent developments in high-temperature superconducting magnet technology (review) *IEEE Trans. Appl. Supercond.* **24** pp. 1-12
- [2] Schwartz J 2013 Quench in high temperature magnets
- [3] Bottura L 2013 Magnet quench 101 *CERN Yellow Report CERN-2013-006* pp.1-9
- [4] Weijers H W et al 2016 progress in the development and construction of a 32T superconducting magnet *IEEE Trans. Appl. Supercond.* **26** pp. 1-7
- [5] Dudarev A V, Gavrilin A V, Ten Kate H, Baynham D E, Courthold M J D and Lesmond C 2000 Quench propagation and protection analysis of the ATLAS Toroids *IEEE Trans. Appl. Supercond.* **10** pp. 365-368
- [6] Ang I C 2006 *Stability and Quench Protection of High-Temperature Superconductors* (Massachusetts Institute of Technology)
- [7] Salmi T and Stenvall A, 2015 Modeling Quench Protection Heater Delays in an HTS Coil *IEEE Trans. Appl. Supercond.* **25** pp.1-5
- [8] Ravaioli E, Datskov V, Dudarev A, Kirby G, Sperin K A, Ten Kate H and Verweij A P 2014 First experience with the new coupling loss induced quench system *Cryogenics* **60**
- [9] Ravaioli E et al. 2015 Towards an optimized coupling-loss induced quench protection system (CLIQ) for quadrupole magnets *Physics Procedia* **67** pp. 215-220

- [10] Van Nugteren J et al, A fast quench protection system for high-temperature superconducting magnets *IEEE Trans. Appl. Supercond.* **29** pp. 1-8
- [11] Ijagbemi K, Noyes P, Stiers E and Pamidi S 2017 Frequency loss induced quench protection system for high temperature superconductors *IOP Conf. Series Materials Science and Engineering* **278** p.012073
- [12] Technical Information IGBT-module FZ600R12KE3 2013 (Infineon)
- [13] Noyes P D, Markiewicz W D, Voran A J, Sheppard W R, Pickard K W, Jarvis J B, Weijers H W and Gavrilin A V 2012 *IEEE Trans. Appl. Supercond.* **22** pp. 4704204
- [14] Senatore C, Barth C and Bonura M, Kulich M and Mondonico G Field and temperature scaling of the critical current density in commercial REBCO coated conductors *Superconductor Science and Technology* **29** p.014002

Acknowledgement

This work was performed at the National High Magnetic Field Laboratory, which is supported by the National Science Foundation Cooperative Agreement No. DMR-1644779 and DMR-1839796, and the State of Florida.